

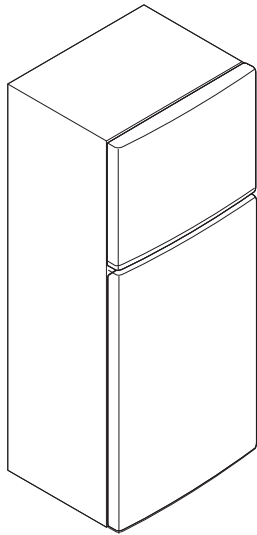

REFRIGERATOR SERVICE MANUAL

CAUTION

BEFORE SERVICING THE UNIT,
READ THE SAFETY PRECAUTIONS IN THIS MANUAL.



MODELS:

LTCS20020*

* = Color Code

Any reproduction, duplication, distribution (including by way of email, facsimile or other electronic means), publication, modification, copying or transmission of this Service Manual is STRICTLY PROHIBITED unless you have obtained the prior written consent of the LG Electronics entity from which you received this Service Manual. The material covered by this prohibition includes, without limitation, any text, graphics or logos in this Service Manual.

Copyright © 2020 LG Electronics Inc. All rights reserved. Only training and service purposes.

CONTENTS

WARNINGS AND SAFETY PRECAUTIONS	2
1. SPECIFICATIONS	3
2. PARTS IDENTIFICATION	4
3. DISASSEMBLY	5
4. TROUBLESHOOTING COMPRESSOR	11
4-1 Compressor activation defect	11
4-2 Service Diagnosis Chart	18
5. COMPRESSOR	19
6. CIRCUIT DIAGRAM	21
7. TROUBLESHOOTING	22
7-1 Compressor and Electric Components	22
7-2 PTC and OLP.....	23
7-3 Other Electric Components	24
7-4 Service Diagnosis Chart	25
7-5 Refrigerating Cycle.....	26
8. CIRCUIT OF MICOM	27
8-1 Function	27
9. SMART DIAGNOSIS & DOOR ALARM	31
10. EXPLODED VIEW	50

SAFETY PRECAUTIONS

Please read the following instructions before servicing your refrigerator.

1. Check the refrigerator for current leakage.
2. To prevent electric shock, unplug before servicing.
3. Always check line voltage and amperage.
4. Use standard electrical components.
5. Don't touch metal products in the freezer with wet hands. This may cause frost bite.
6. Prevent water from spilling on to electric elements or the machine parts.
7. Before tilting the refrigerator, remove all materials from on or in the refrigerator.
8. When servicing the evaporator, wear gloves to prevent injuries from the sharp evaporator fins.
9. Service on the refrigerator should be performed by a qualified technician. Sealed system repair must be performed by a CFC certified technician.

1. SPECIFICATIONS

SPECIFICATIONS		MODEL		
		LTCS20020*		
GENERAL FEATURES	Color	Super White / Stainless Steel / Western Black		
	Dimensiones (W x D x H)	29.9 x 33.9 x 66.1 in		
	Net Weight	91.6 kg		
	Capacity	20 cu ft		
	Refrigerant	R600a		
	Climate Class	Temperate (N)		
	Rated Rating	115V~ / 60Hz		
	Cooling System	Fan Cooling		
	Temperature Control	MICOM control		
	Defrosting System	Full Automatic		
		Heater Defrost		
	Insulation	Polyurethan		
	Compressor	BMG110NHMV		
	Evaporator	Fin Tube Type		
	Condenser	Wire Condenser		
	Lubricating Oil	Polyol Ester (POE) RL-7H/7 cst 220 ± 10 cc		
	Drier	MOLECULAR SIEVE XH-7		
	Capillary Tube	ID Ø0.75		
	First Defrost	4 Hours		
	Defrost Cycle	7 - 40 Hours		
Defrosting Device	Heater, Sheath			
REFRIGERATOR	Case Material	Embo (Normal)		
	Door Material	PCM	STS	PCM
	Handle Type	Pocket Handle		
	Basket, Quantity	2 full + 1 small		
	Ice Tray & Bank	Ice Bin		
	Cover, T/V	Humidity Control		
	Lamp	LED (1)		
	Shelf	Glass (2)		
	Tray meat	No		
	Tray egg	No		
FREEZER	Basket, Quantity	Plastic (2)		
	Lamp	N/A		
	Shelf	Glass (1)		

2. PARTS IDENTIFICATION

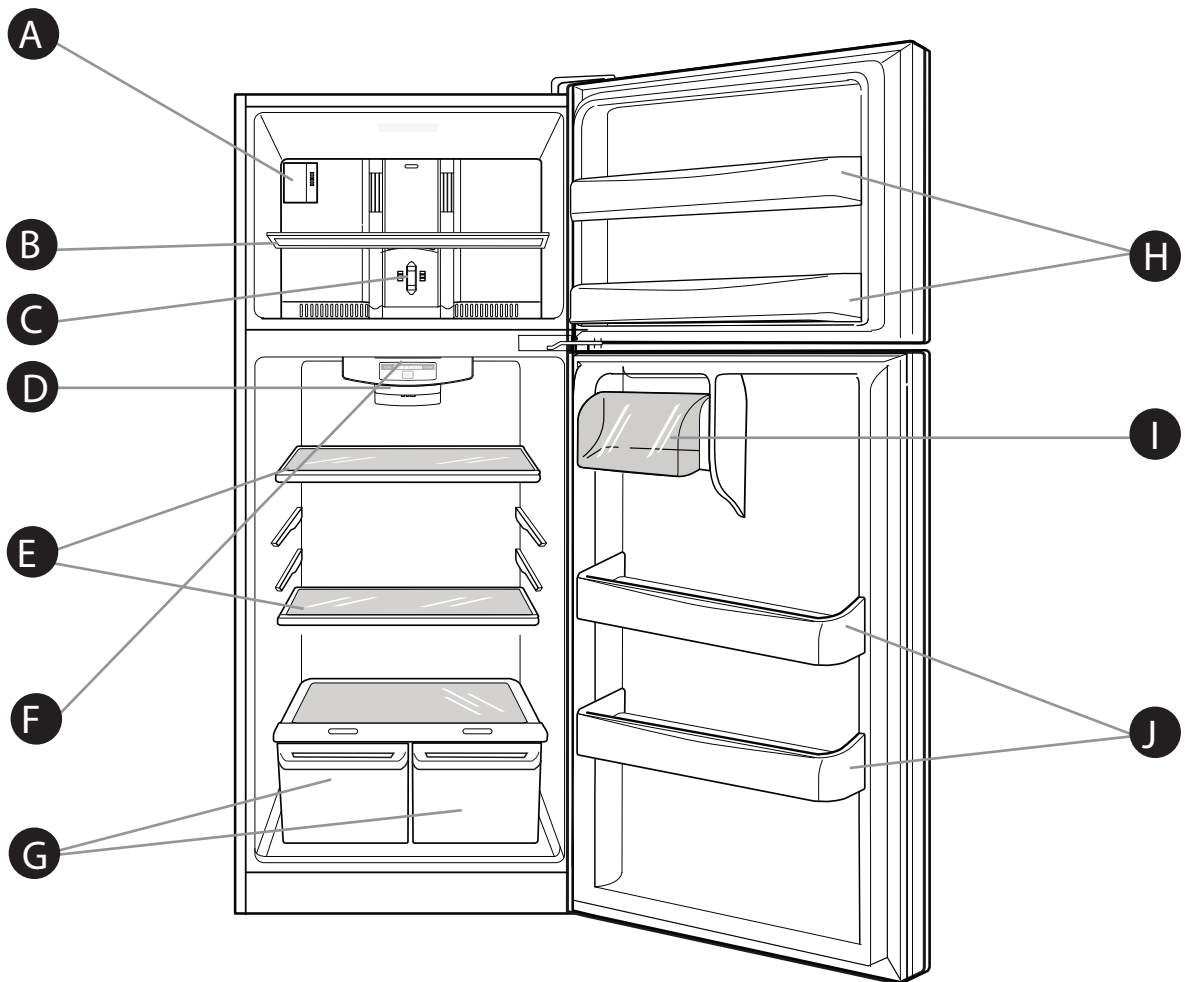

Use this page to become more familiar with the parts and features of your refrigerator. Page references are included for your convenience.

NOTE: This guide covers several models. The refrigerator you have purchased may have some or all of the items listed below. The locations of the features shown below may not match your model.

- | | |
|---|---------------------------------|
| A Custom Cube Icemaker | G Crispers |
| B Freezer Shelf | H Freezer Door Bins |
| C Freezer Temperature Control | I Dairy Bin |
| D Refrigerator Temperature Control | J Refrigerator Door Bins |
| E Shelves | |
| F Refrigerator Light (LED) | |

3. DISASSEMBLY

(For additional support on this topic, including helpful videos, please visit us at: www.lg.com).

If entrance is less than 35 inches wide, the refrigerator's door will need to be removed.

IMPORTANT: Before starting, turn off and unplug the refrigerator. Remove all food and the racks from the doors.

TOOLS YOU MIGHT NEED OR USE

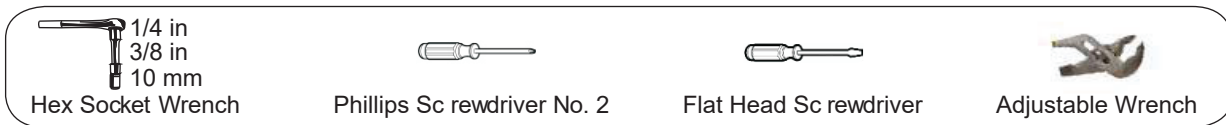

⚠ WARNING

ELECTRICAL SHOCK HAZARD

Before you begin, either unplug the refrigerator or turn off the power at the circuit breaker or fuse box. Remove food and any door rack from the refrigerator. Failure to do so could result in death or serious injury.

1. Removing Freezer Door

- Gently pry off the Top Hinge Cover with a flat head screwdriver and remove it. See Fig. 1.

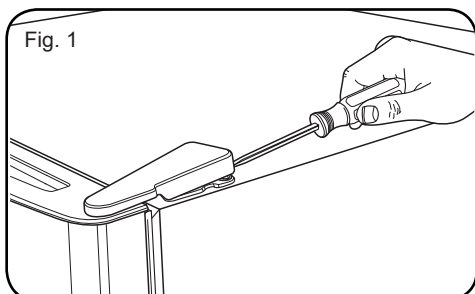

- Using 10 mm or 3/8 inch socket wrench, remove the three bolts and lift the Top Hinge (See Fig. 2). Set parts aside.

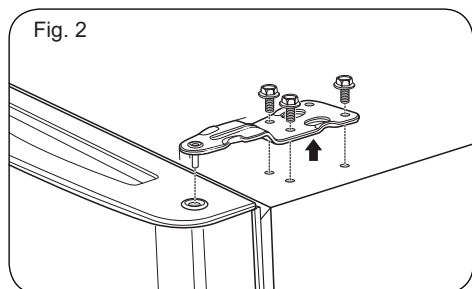

- Lift freezer door slightly and remove it (See Fig. 3) Set parts aside.

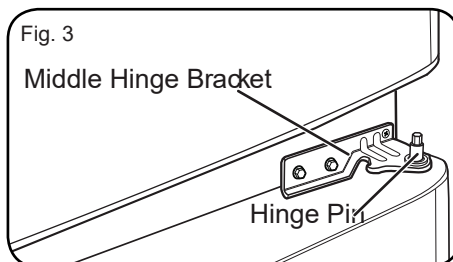

2. Removing Refrigerator Door

- Loosen and remove the two bolts and the screw to remove the middle hinge bracket from refrigerator housing (Figure 4). Set parts aside (Figure 5).

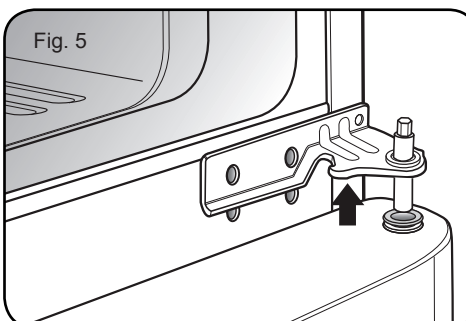
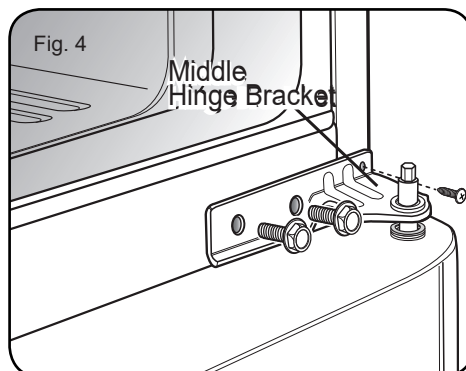

- Lift up door slightly and remove it (See Figure 6).

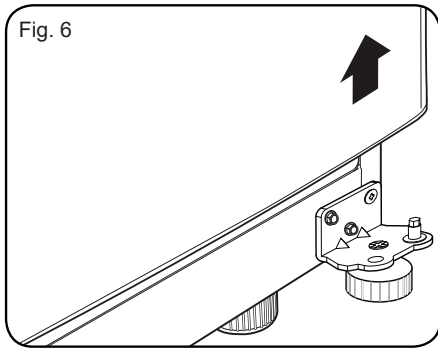

- To replace doors, begin with refrigerator door and then follow with freezer door.

3. Replacing Refrigerator Door

- Set door on Bottom Hinge Pin (See Figure 7).
- Place hinge pin of middle bracket inside the hinge pin insert on the top of the door (See Figure 8). Hold the door in place and line up the hinge with the holes in the refrigerator housing.

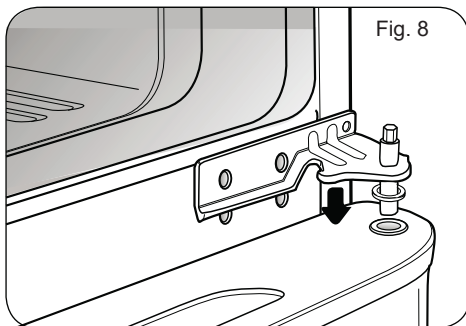
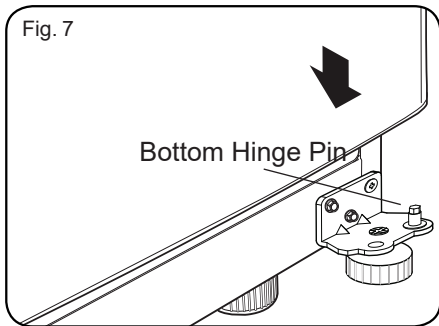

- Use the two bolts and the screw to refasten the middle hinge with the refrigerator housing. See Figure 9.

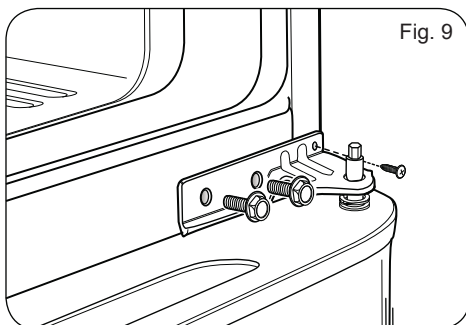

4. Replacing Freezer Door

- Set the freezer door onto the Middle Hinge pin (Figure 10).
- Place upper hinge in the top of the freezer door and line up the hinge with the holes in top of refrigerator. Use the three bolts to fasten the hinge (See Figure 11).

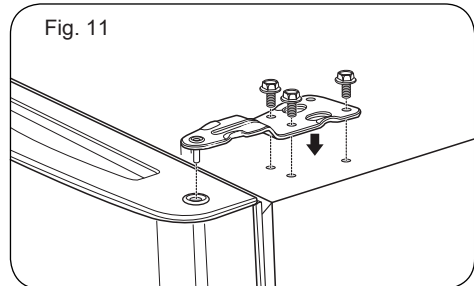
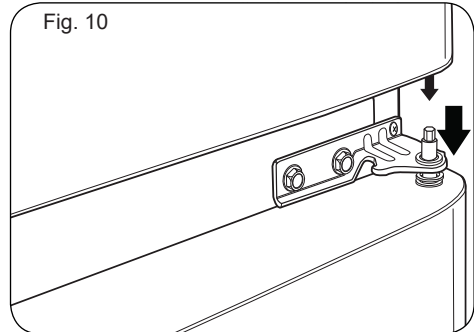

- Carefully, force the top hinge cover back into place over hinge (See Figure 12).

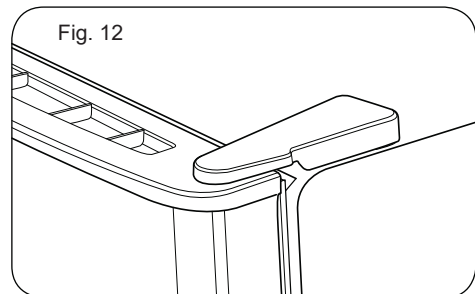

HOW TO REVERSE AND INSTALL THE REFRIGERATOR DOORS

You may find it more convenient to have the doors converted from the left opening type (factory installed) to the right opening type. Directions refer to the right side as the side on your right as you face the unit.

TOOLS YOU MIGHT NEED OR USE

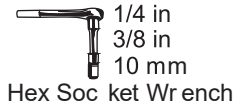

⚠ WARNING

ELECTRICAL SHOCK HAZARD

Before you begin, either unplug the refrigerator or turn off the power at the circuit breaker or fuse box. Remove food and any door rack from the refrigerator. Failure to do so could result in death or serious injury.

1. Removing Freezer Door

Gently pry off the top hinge cover with a flat head screwdriver and remove.

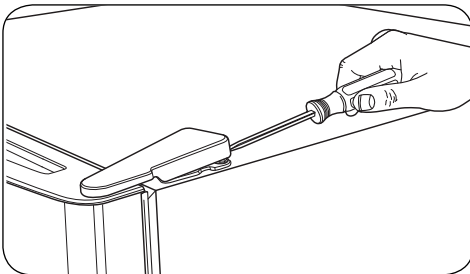

Using 10mm or 3/8 inch socket wrench, remove the three bolts and lift off the top hinge. Set parts aside.

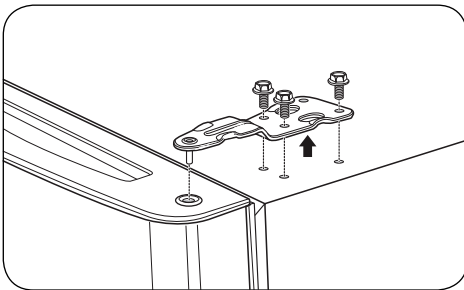

Slightly lift up the refrigerator door and remove it.

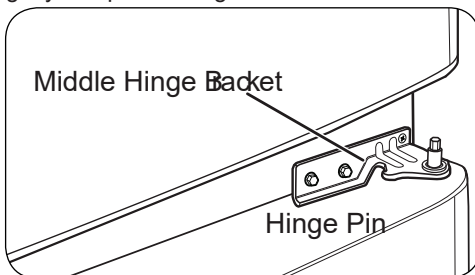

Turn the freezer door upside down on a non-scratch surface. Loosen the screw to remove the Door Closer/Stop and Hinge Pin Insert.

Move the Hinge Pin Insert Bracket to the other side of the door, keeping the same orientation, and move the Hinge Pin Insert into the hole on the left side of the bracket.

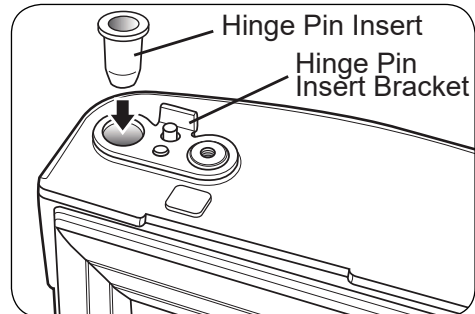

Reverse the Door Closer/Stop by flipping it over. Place it on top of the Hinge Pin Insert Bracket, and tighten both down with the screw.

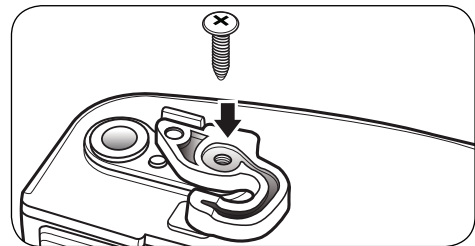

Pry off the cover on the top left side of the refrigerator to uncover the screw holes.

Set the freezer door and top hinge parts to the side and remove the refrigerator door.

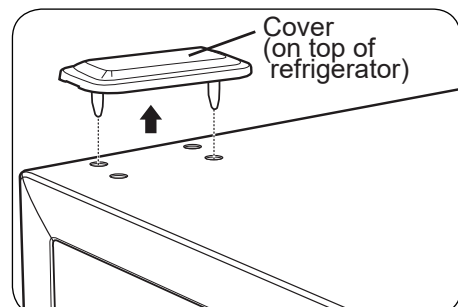

2. Reversing and Reinstalling Refrigerator Door

Using a 1/4" socket wrench, loosen and remove Hinge Pin from the Middle Hinge Bracket. Remove washer underneath the middle hinge and set aside.

NOTE: At this point the door will be loose. Slightly lift the door and remove it.

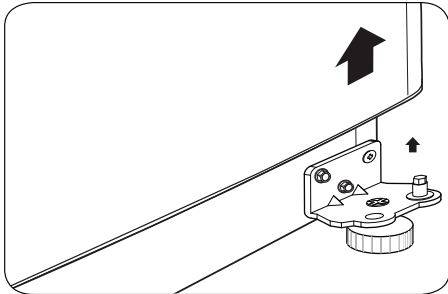
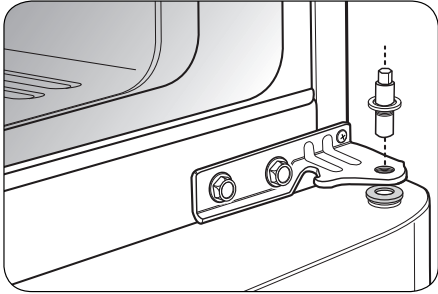

Loosen and remove the two bolts and use the Phillips head screwdriver to remove the Middle Hinge Bracket from the refrigerator housing. Set parts aside.

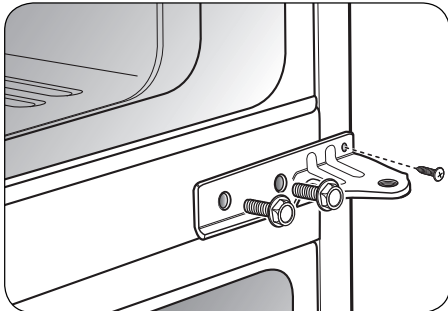

Remove the washer from the Bottom Hinge Pin. Using a 1/4" socket wrench, loosen and remove the Hinge Pin from the Bottom Hinge. Reattach the Hinge Pin to the opposite side of the hinge. NOTE: This is easier to do while the hinge is still attached.

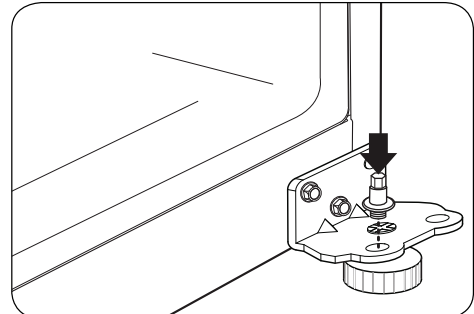
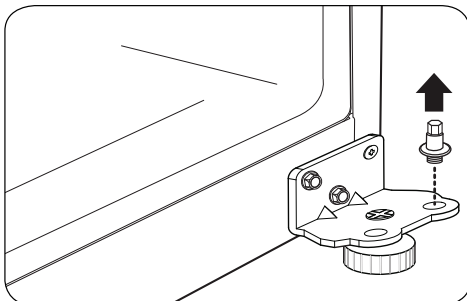

Using a 3/8" socket wrench with a 2-Inch extension and screwdriver, loosen the two bolts and one screw, and remove the Bottom Hinge from right side of the housing.

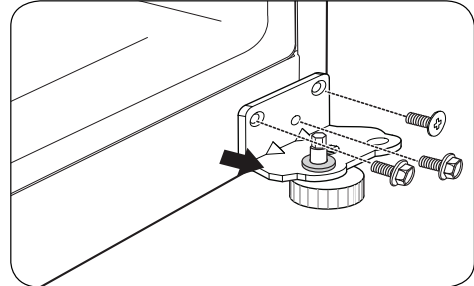

Remove the Decorative Caps on the bottom of the refrigerator housing. You will need these holes for the Bottom Hinge.

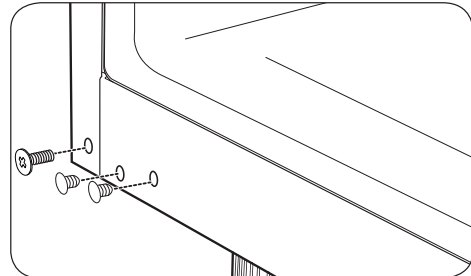

Move the Bottom Hinge to the left side of the housing, keeping the same orientation, and reattach with the two bolts and one screw. The flat screw must be placed on the exterior side of the hinge. Move the Decorative Bolt to the hole on the lower right side of the housing.

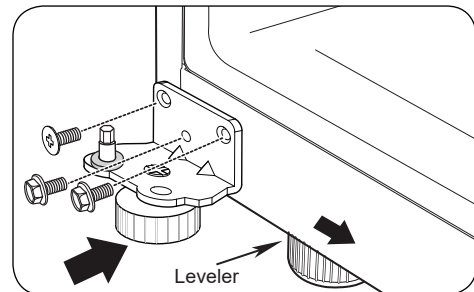

Turn the refrigerator door upside down on a nonscratching surface. Loosen the two screws to remove the Bottom Hinge Pin Insert Bracket with the Hinge Pin Insert.

⚠️ WARNING: If you reinstall or replace doors, move the leveler to the opposite side.

NOTE: The leveler is only present on some models.

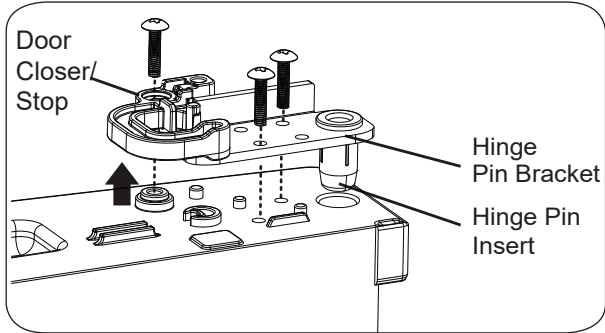

Reverse the Door Closer/Stop by flipping it over. Place it on top of the Hinge Pin Insert Bracket, and tighten both down with the screw. Tighten the Hinge Pin Bracket to the door.
 NOTE: The Door Closer Stop is only presented on some models.

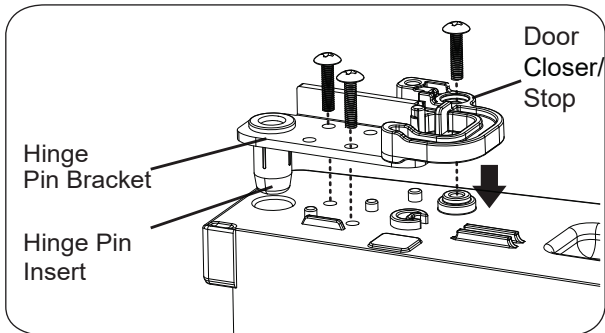

With a flat-head screwdriver, carefully pry off and remove the cover over the screw holes on the left side of refrigerator housing.

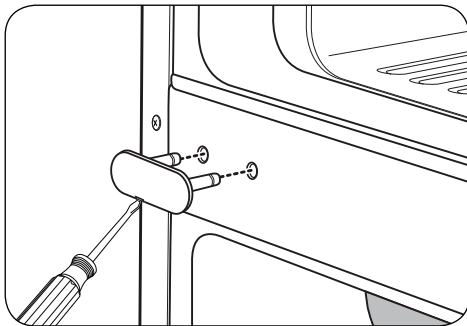

Remove the outer lower Decorative Screw from the housing at the area between the freezer and refrigerator doors. (You will need this hole for the Middle Hinge Bracket.)

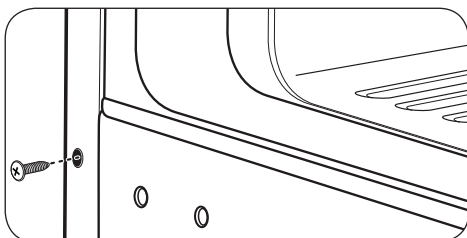

Flip the Middle Hinge Bracket, (flange will now be on top) position it on left side of the refrigerator and reattach with two bolts and a Phillips screwdriver. Place the refrigerator door down over the pin on the bottom hinge. Place the washer between the refrigerator door and middle hinge and re-attach Hinge Pin to Hinge Bracket with a 1/4" socket wrench.
 NOTE: Bracket has been flipped, but Hinge Pin stays in the same orientation with its hexagonal end facing upward.

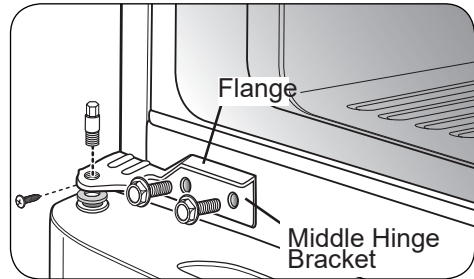

Insert the Decorative Screw into the outer hole on the right side of the housing. Attach cover on the right side. Cover is force-fitted.

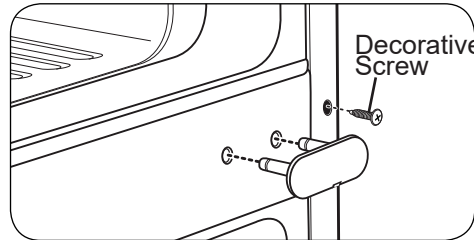

REATTACHING THE DOORS

Place the freezer door down over the Hinge Pin on the Middle Hinge Pin Bracket.

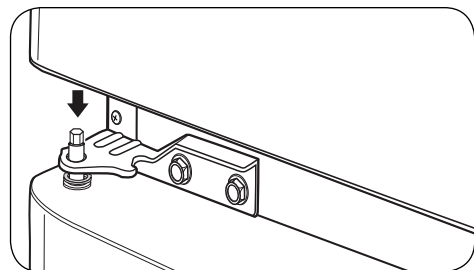

Place the Upper Hinge Pin on top of the freezer door and line up the Upper Hinge with holes on top of the refrigerator. Use the three bolts to replace the Hinge.

After changing the doors, make sure that the corners of the Door Gaskets are not folded over. To ensure a good seal, apply a small amount of silicon grease on the corners of gaskets.

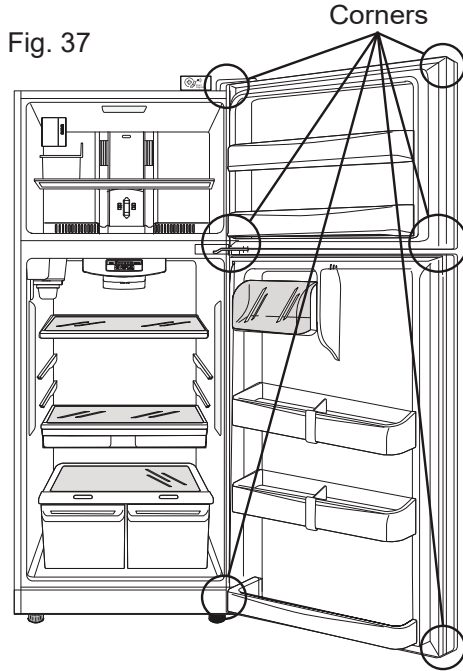

CLOSING AND ALIGNING THE DOORS

To avoid vibration, the unit must be leveled. If necessary, adjust the Leveling Legs to compensate for unevenness of the floor. The front should be slightly higher than the rear to aid in door closing.

Your refrigerator has three front leveling screws, one on the right and one on the left. If your refrigerator seems unstable or if you would like the doors to close more easily, simply adjust the inclination of the refrigerator by following the instructions below:

NOTE: Third leveling screw is used for protection of hinge lower.

1. Plug the refrigerator into a 3 prong grounded outlet. Move the refrigerator into its final position.

2. Use a flat head screwdriver to adjust the leveling screws (see Figure A), turning clockwise to raise the side of the refrigerator and counter-clockwise to lower it. It may take several turns to adjust it to the inclination you would like.

NOTE: Having someone push against the top of the refrigerator takes some weight off the leveling screws. This will make it easier to adjust the screws.

3. Open both doors again and check to make sure that they close easily. If not, tilt the refrigerator slightly more to the rear by turning both Leveling Screws clockwise. It may take several more turns, and you should turn both Leveling Screws the same times.

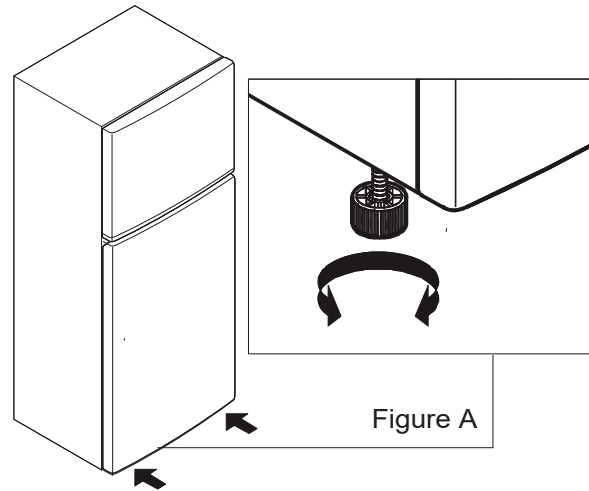

DOOR ALIGNMENT

If the space between your doors is uneven, follow the instructions below to align the doors.

1. Gently pry off the refrigerator door Top Hinge Cover with a flat head screwdriver and remove. Loosen the Top Hinge Bolts using a 10 mm or 13/32inch socket wrench or opened wrench.
2. Have a second person hold the refrigerator door in its proper position.
3. Replace the Top Hinge Cover.

FAN AND FAN MOTOR

1. Remove the freezer shelf. (If your refrigerator has an icemaker, unplug and remove the icemaker first).
2. Remove the screw of the grille fan.
3. Remove the grille by pulling it out.
4. Remove the Fan Motor assembly by loosening 4 screws and disassemble the shroud.
5. Pull out the fan and separate the Fan Motor and Bracket.

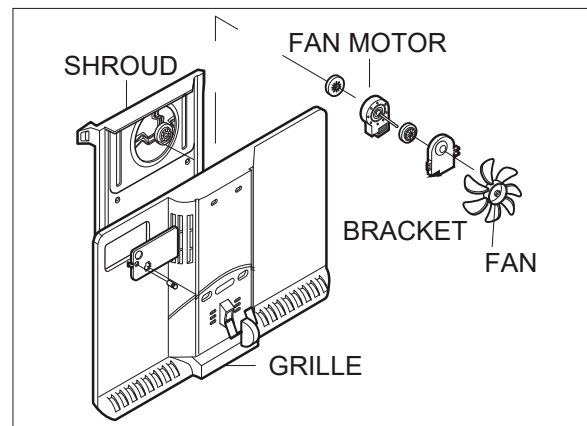

4. TROUBLESHOOTING COMPRESSOR

4-1 Compressor activation defect

①

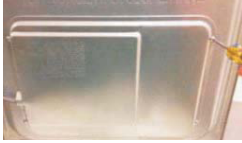

- Open PWB Cover

②

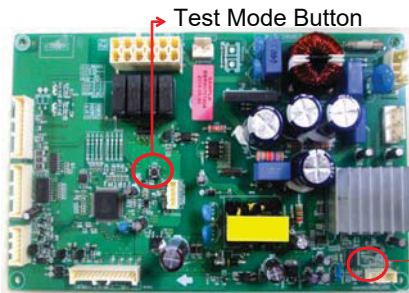

Test Mode Button



If COMP is normal it will not blink

- Check the number of LED blinking
(Refer to the next chapter for actions for each number of LED blinking)

③



- Open back cover

④

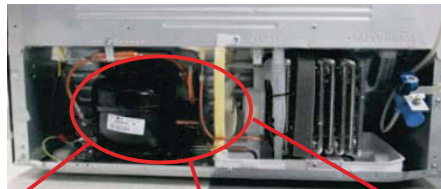

1. CHECK COMP and Discharge PIPE temperature

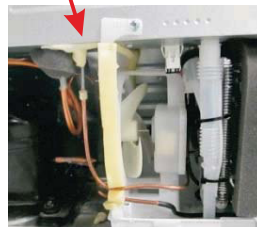

2. Check wheter C-Fan operates

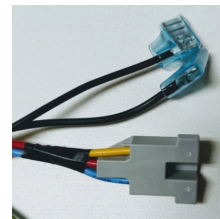

- Check disconnection in OLP and Comp connection (U,V,W=SB, YL, RD)

If COMP & FAN are not operated at the same time, check the operation after forcing the operation in TEST MODE in MAIN PCB, and perform power RESET after checking the voltage on COMP side.

Compressor SVC Manual

1. Check LED Trip



1. Separate PCB COVER, and check number of LED blinking.
2. Verify the actions for each number of blinking → Check when it is not RESET(Before turning off the power of the refrigerator).
3. Write the service information according to the number of LED blinking.
4. Write SVC information, and check again after power reset.

→Refer to the actions for each number of Trip and LED blinking

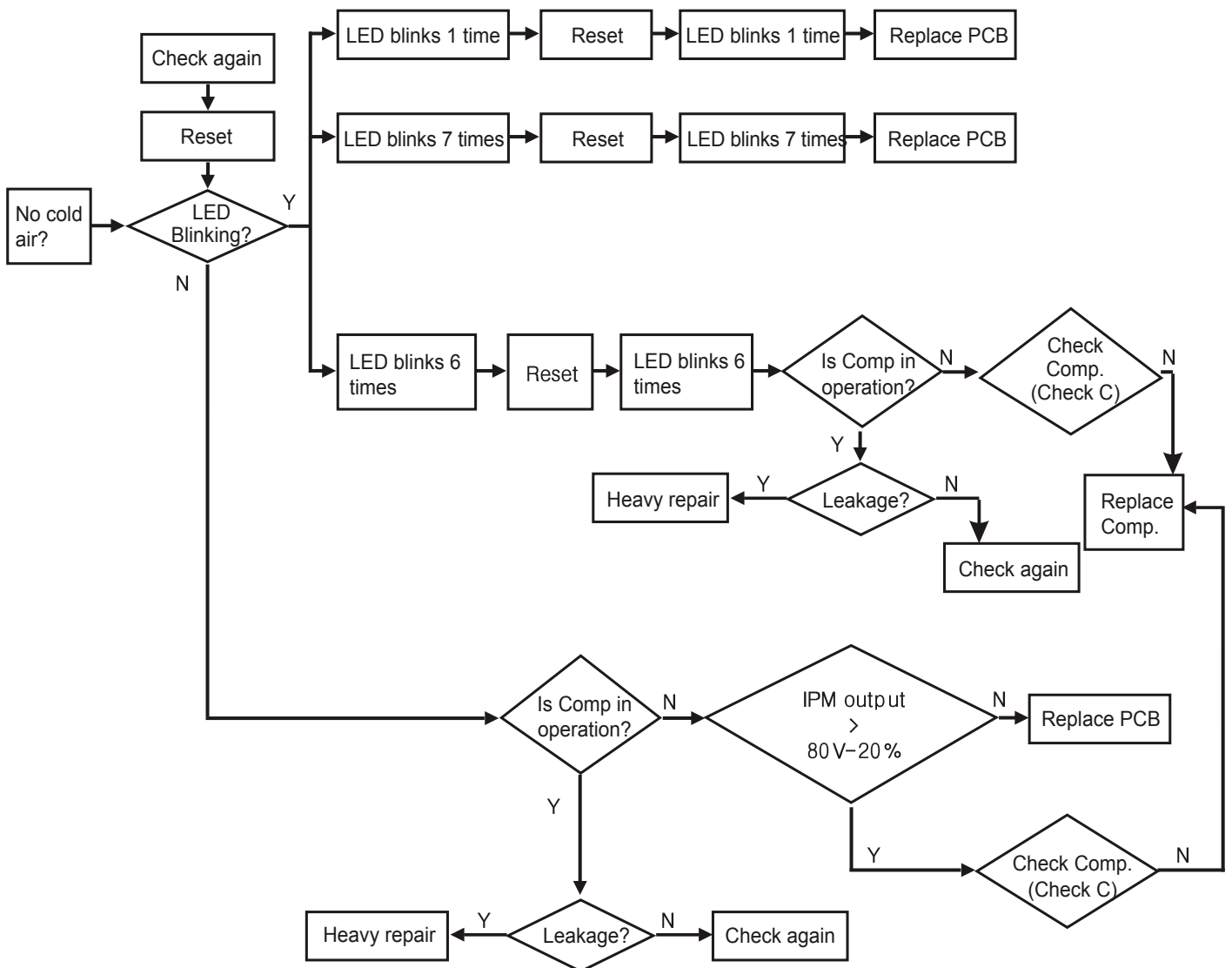
Simple Check order



Actions for each number of LED blinking

1	<p>LED 1 time repeated</p>  <p>..Blink -Off -Blink -Off -Blink -Off -Blink -Off -Blink -Off -Blink -Off -Blink -Off -Blink -Off - .. Repeated</p>	AD-offset Error	<ol style="list-style-type: none"> 1. Check normal operation after power reset 2. If same error occurs after 1, replace PCB.
2	<p>LED 6 times repeated</p>  <p>..Blink -Blink-Blink-Blink-Blink-Blink-Off -Blink -Blink-Blink-Blink-Blink-Blink-Off - .. Repeated</p>	Circuit over-current error	<ol style="list-style-type: none"> 1. Check normal operation after power reset 2. If same error occurs after 1, replace PCB. 3. If same error occurs after 2, replace COMP unit.
3	<p>LED 7 times repeated</p>  <p>..Blink -Blink-Blink-Blink-Blink-Blink-Blink-Off -Blink -Blink-Blink-Blink-Blink-Blink-Off - .. Repeated</p>	PCB defect part (IPM)	<ol style="list-style-type: none"> 1. Check normal operation after power reset 2. If same error occurs after 1, replace PCB.

Actions for each Trip and number of LED blinking

1. LED blinking 1 time (AD-offset Error)



→Cause : PCB Short, sensing part defect

→Objective: to detect Motor voltage or current sensing defect

→Actions: check CC310 voltage and if it is outside 2.2~2.8V, replace PCB

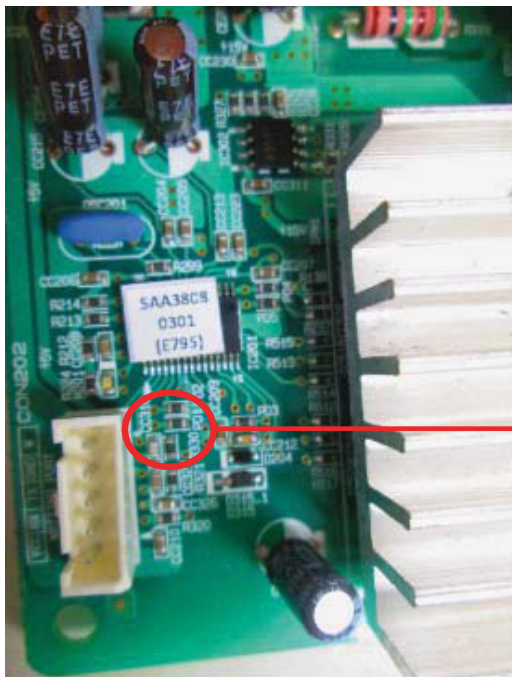
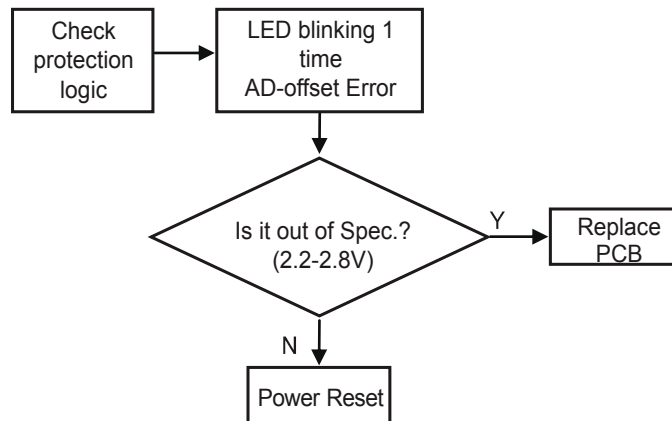

Actions for each number of TRIP and LED blinking

2. Current Trip and LED blinking 6 times (Current Trip)



⌚ 6 times blinking (Current Trip) may occur in a situation like temporary blackout such as refrigerator power off/on within 3 min.

1. If it blinks 6 times, but there is no significant difference between the temperature inside the refrigerator and the set temperature, there is no problem in PCB, Compressor, or Cycle.

2. If it blinks 6 times and problem such as no cooling occurs, it means cycle leakage or cycle clogged (moisture, trash).

→Cause: Cycle leakage or clogging, excessive Compressor temperature increase, compressor piston locked, PCB IPM device burned due to Condenser fan defect

→Cause: Over-current protection

→Action: Check PCB output, Check operation of the Compressor single unit, leakage inspection and check cycle clogging (For re-vacuum, 30min. additional vacuum)

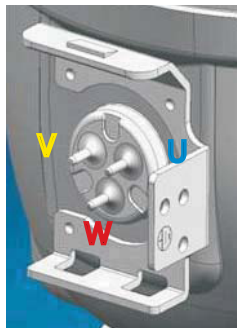
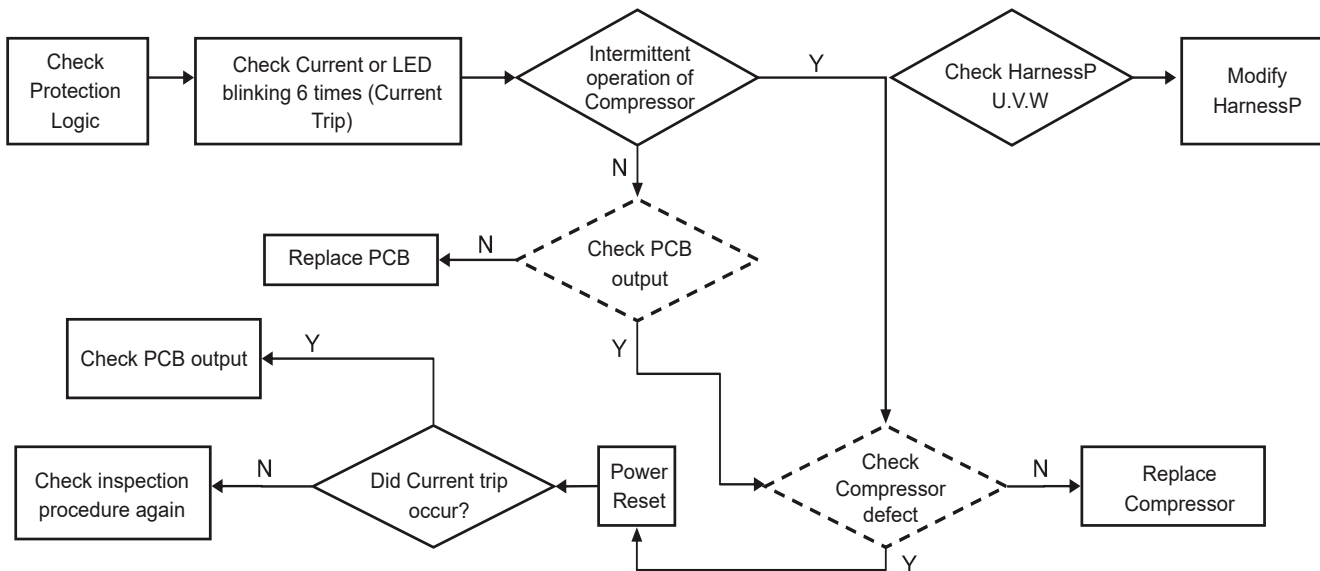

Actions for each TRIP and the number of LED blinking

3. LED blinking 7 times (IPM Fault)



Blink Blink Blink Blink Blink Blink Blink OFF

- Cause: IPM Short, defect(burned or damaged)
- Objective: Protection of the over-current caused by IPM short or defect.
- Actions: Visual verification of IPM burn when COMP is not in operation. Check whether there is a short circuit in U, V, or W part.
- Replace PCB

P/N: EBR807574**

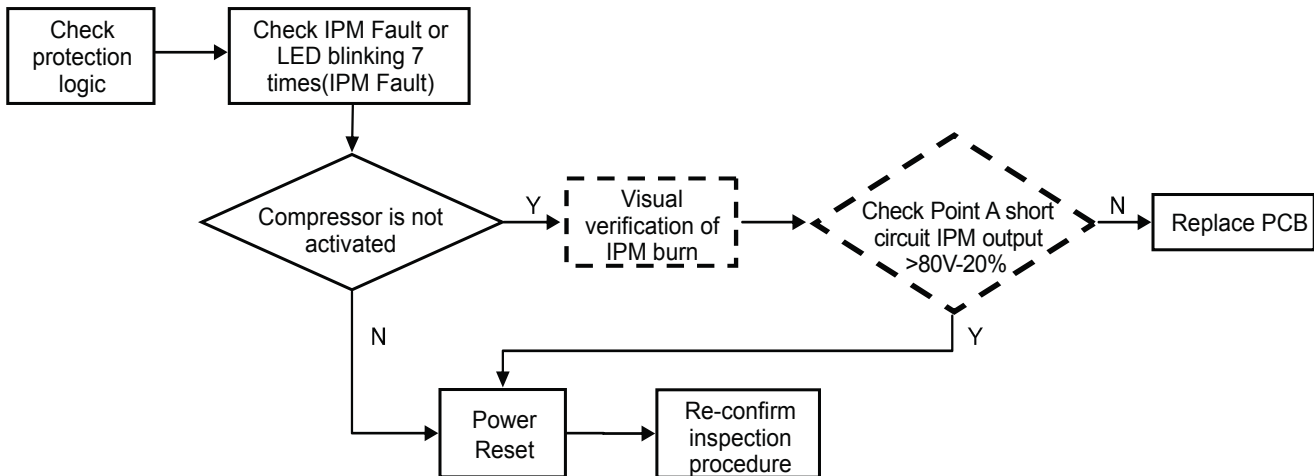
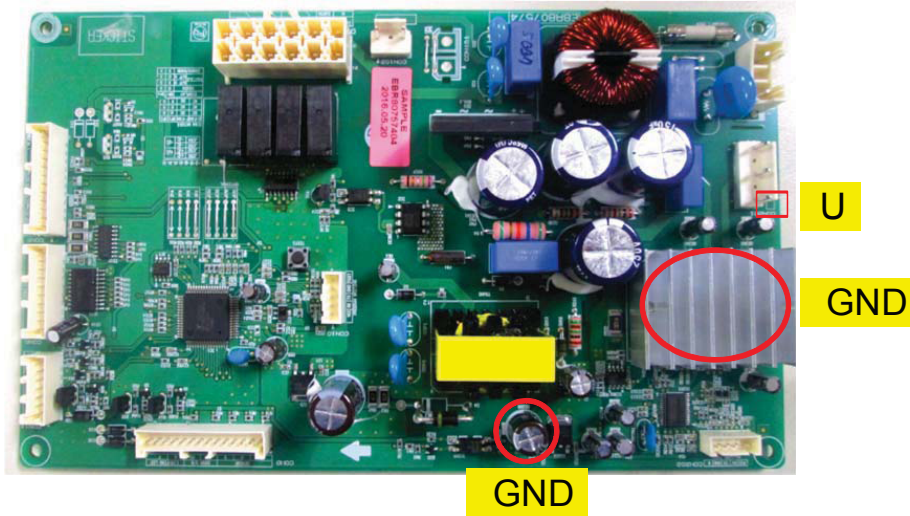

Check COMPRESSOR & HARNESS

- Measure COMP connector resistance (Power & Common)
- Check insulation destruction : measure the resistance between the COMP power connector and the grounding.

Copyright © 2020 LG Electronics Inc. All rights reserved.
Only training and service purposes.

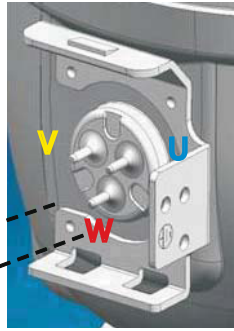
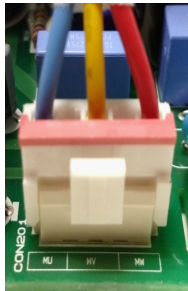
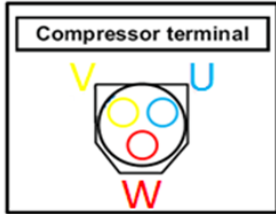

Multi Tester

Compressor	Motor resistance
BMG110NAMV	

※ There may be difference of several Ω in the resistance value according to the ambient temperature or operation condition.

4-1 ANOTHER ELECTRIC COMPONENTS

▼ Cooling ability is poor

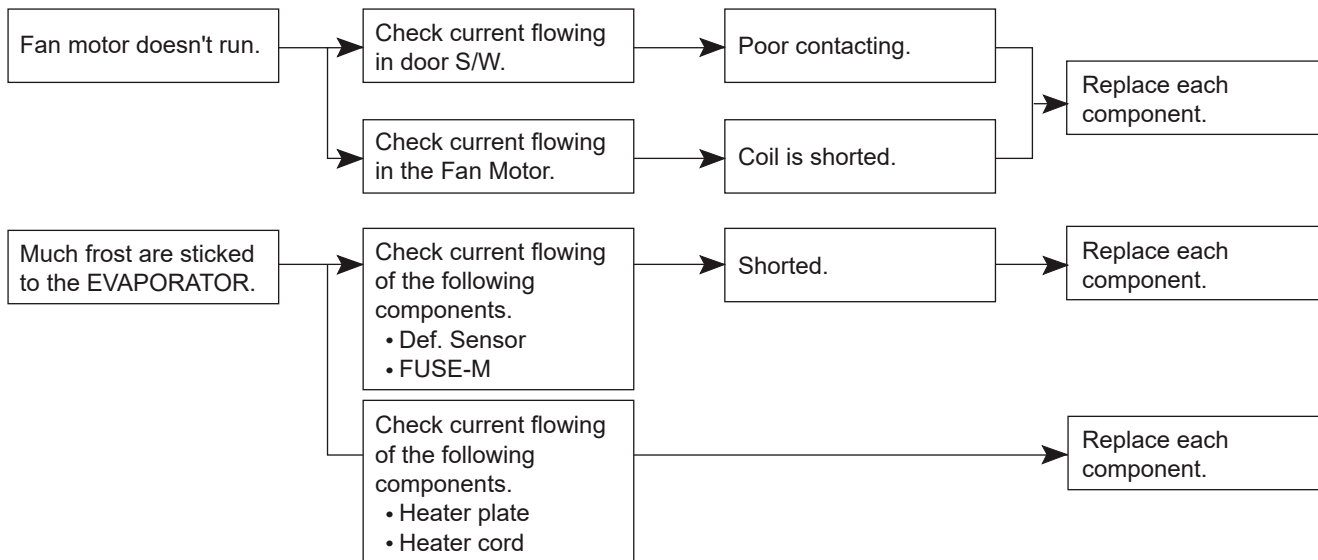

4-2 SERVICE DIAGNOSIS CHART

COMPLAINT	POINTS TO BE CHECKED	SERVICE ACTION
Cooling is impossible.	<ul style="list-style-type: none"> Is the power cord unplugged from the outlet? Checked if the power S/W is set to OFF. Check if the fuse of power S/W is shorted. Measure the voltage of power outlet. 	<ul style="list-style-type: none"> Plug to the outlet. Set the switch to ON. Replace a regular fuse. If voltage is low, wire newly.
Cooling ability is poor.	<ul style="list-style-type: none"> Check if the set is placed close to wall. Check if the set is placed close to stove, gas, cooker and direct rays. Is the ambient temperature high or the room door closed? Check if putting in hot foods. Did you open the door of the set too often or check if the door is closed up? Check if the Control is set to "Min". 	<ul style="list-style-type: none"> Place the set with the space of about 10cm Place the set apart from these heat appliances. Make the ambient temperature below. Put in foods after they get cold. Don't open the door too often and close it firmly. Set the control to mid-position.
Foods in the refrigerator are frozen.	<ul style="list-style-type: none"> Are foods placed in cooling air outlet? Check if the Display LED is set to "0-1". Is the ambient temperature below 5°C. 	<ul style="list-style-type: none"> Place foods in high temperature section. (Front part) Set the Display LED to "3". Set the Display LED to "5-6".
Dew or ice forms in the chamber of the set set.	<ul style="list-style-type: none"> Is watery foods kept? Check if putting in hot foods. Did you open the door of the set too often or check if the door is closed up. 	<ul style="list-style-type: none"> Seal up watery foods with wrap. Put in foods after they get cold. Don't open the door too often and close it firmly.
Dew forms in the Out Case.	<ul style="list-style-type: none"> Check if ambient temperature and humidity of surrounding air are high. Is the gap in the door packed? 	<ul style="list-style-type: none"> Wipe dew with a dry cloth. This happening is solved in low temperature and humidity naturally. Fill up the gap.
Abnormal noise generates.	<ul style="list-style-type: none"> Is the set positioned in a firm and even place? Does any unnecessary objects exists in the back side of the set? Check if the Drip tray is not firmly fixed? Check if the cover of mechanical room in below and back side is taken out. 	<ul style="list-style-type: none"> Adjust the leveling screw, and position in the firm place. Remove the objects. Fix it firmly on an original position. Place the cover at an original position.
To close the door is not handy.	<ul style="list-style-type: none"> Check if the door packing becomes dirty by filth such as juice. Is the set positioned in a firm and even place? Is too much food putted in the set? 	<ul style="list-style-type: none"> Clean the door packing. Position in the firm place and adjust the adjust screw. Keep foods not to reach the door.
Ice and foods smell unpleasant.	<ul style="list-style-type: none"> Check if the inside of the set becomes dirty. Did you keep smelly foods without wrapping? It smells plastic. 	<ul style="list-style-type: none"> Clean the inside of the set. Wrap smelly foods. The new products smell plastic, but it is removed after 1-2 weeks.

- In addition to the items describes left, refer to the following to solve the complaint.

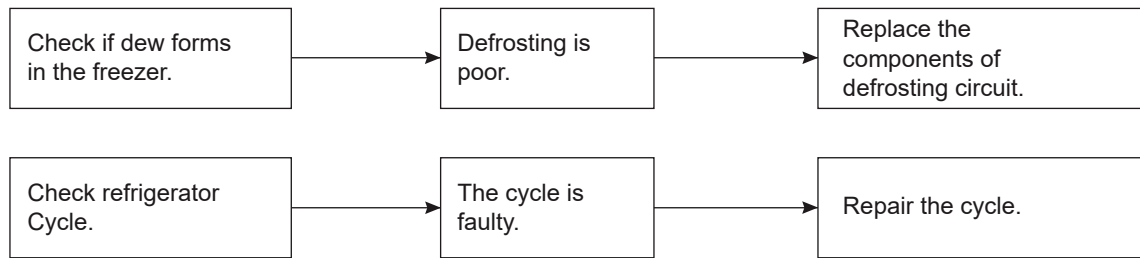

5. COMPRESSOR

1. How to find out Inverter BLDC Compressor defect

If Inverter BLDC Compressor defect occurs, you can check in the following order.

1-1. How to measure Compressor winding resistance

Standard for judging normality

When the resistance value of Harness (connected to Compressor) connecting Main PWB Connect201 (CON201), if the resistance value shows the value of the level in the following figure, you can say that it is normal.

Standard for judging defect

If the resistance value measured in point A in the figure shows infinity or several hundred, check the locking status of Compressor connecting Harness-P (Lead Wire) in the machine room, separate machine room Connect (B point in the figure), and measure resistance value of Connect again. If the resistance value shows the standard resistance value, Compressor can be judged to be normal. Check Harness connection status.

(Machine Room Connect Contact Defect, CON201 Housing Contact Defect, Harness Disconnection) If the resistance value measured at B point also shows infinity or several hundred, disassemble Cover PTC of the Compressor connector, and check the locking status of the terminal at D point in the figure. If it is normal, check the contact status of O.L.P. fixed inside Cover PTC. The problem in O.L.P. may be judged by the resistance values at both ends of O.L.P. If both ends of O.L.P. are measured and the resistance value shows 5 or less, it is normal. If the resistance value is big, it may be judged as O.L.P. disconnection, and compressor does not operate because of no power supply.

If there is no problem in the connection status, and resistance value shows infinity or several hundred, it may be judged as Compressor defect.

If there is no problem with the resistance value of the Compressor, it may be Main PWB defect, so check PCB defect.

During the judgment of defect through resistance measurement, if the resistance values of No.1 and No. 3 of CON201 show the value in the level presented below, motor winding may be judged as normal.

Cautions

1. Make sure to turn off the power of the refrigerator, and measure after several minutes have passed.

2. If the resistance is not correctly measured, you may have wrong judgment.

(The resistance value may have differences of several)

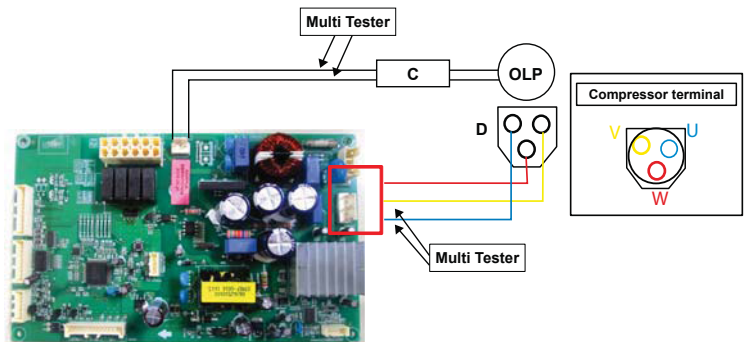

Compressor	Motor resistance
BMG110NAMV	13.85 ± 5

※ There may be resistance value differences of several Ω according to the ambient temperature or operation condition.

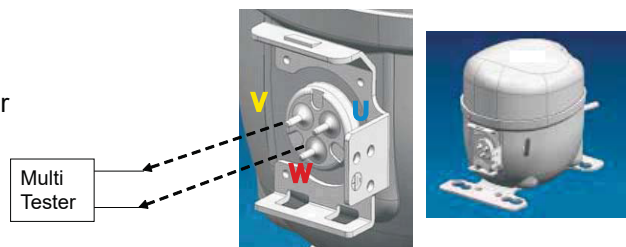

▼ General Control of Refrigerating Cycle

NO.	ITEMS	CONTENTS AND SPECIFICATIONS	REMARKS
1	WELDING ROD	(1) H 30 <ul style="list-style-type: none"> • Chemical Ingredients Ag : 30%, Cu : 27%, Zn : 23%, Cd : 20% • Brazing Temperature : 710~840°C (2) Bcup-2 <ul style="list-style-type: none"> • Chemical Ingredients Cu : About 93% P : 6.8~7.5% The rest : within 0.2% • Brazing Temperature : 735~840°C 	<ul style="list-style-type: none"> • Recommend H34 containing 34% Ag in the Service Center.
2	FLUX	<ul style="list-style-type: none"> • Ingredients and how to make Borax 30% Borax 35% Fluoridation kalium : 35% Water : 4% Mix the above ingredients and boil until they are transformed into liquid. 	<ul style="list-style-type: none"> • Make amount for only a day. Holding period : 1 day • Close the cover of container to prevent dust putting in the FLUX. • Keep it in a stainless steel container.
3	DRIER ASM	(1) Assemble the drier within 30min. after unpacking. (2) Keep the unpacked drier at the temperature of 80~100°C.	<ul style="list-style-type: none"> • Don't keep the drier in a outdoor because humidity damages to it.
4	VACUUM	(1) When measuring with pirant Vacuum gauge of charging M/C, vacuum degree is within 1 Torr. (2) If the vacuum degree of the cycle inside is 10 Torr. below for low pressure and 20 Torr. for high pressure, it says no vacuum leakage state. (3) Vacuum degree of vacuum pump must be 0.05 Torr. below after 5 min. (4) Vacuum degree must be same to the value described item (2) above for more than 20 min.	<ul style="list-style-type: none"> • Apply M/C Vacuum Gauge without fail. • Perform vacuum operation until a proper vacuum degree is built up. • If a proper vacuum degree isn't built up, check the leakage from the Cycle Pipe line part and Quick Coupler Connecting part.
5	DRY AND AIR NITROGEN GAS	(1) The pressure of dry air must be more than 12~16Kg/cm ² (2) Temperature must be more than -20~-70°C. (3) Keep the pressure to 12~6Kg/cm ² also when substituting dry air for Nitrogen Gas.	
6	NIPPLE AND COUPLER	(1) Check if gas leaks with soapy water. (2) Replace Quick Coupler in case of leakage.	<ul style="list-style-type: none"> • Check if gas leaks from connecting part of Coupler.
7	PIPE	<ul style="list-style-type: none"> • Put all Joint Pipe in a clean box and cover tightly with the lid so that dust or humidity is not inserted. 	

6. CIRCUIT DIAGRAM

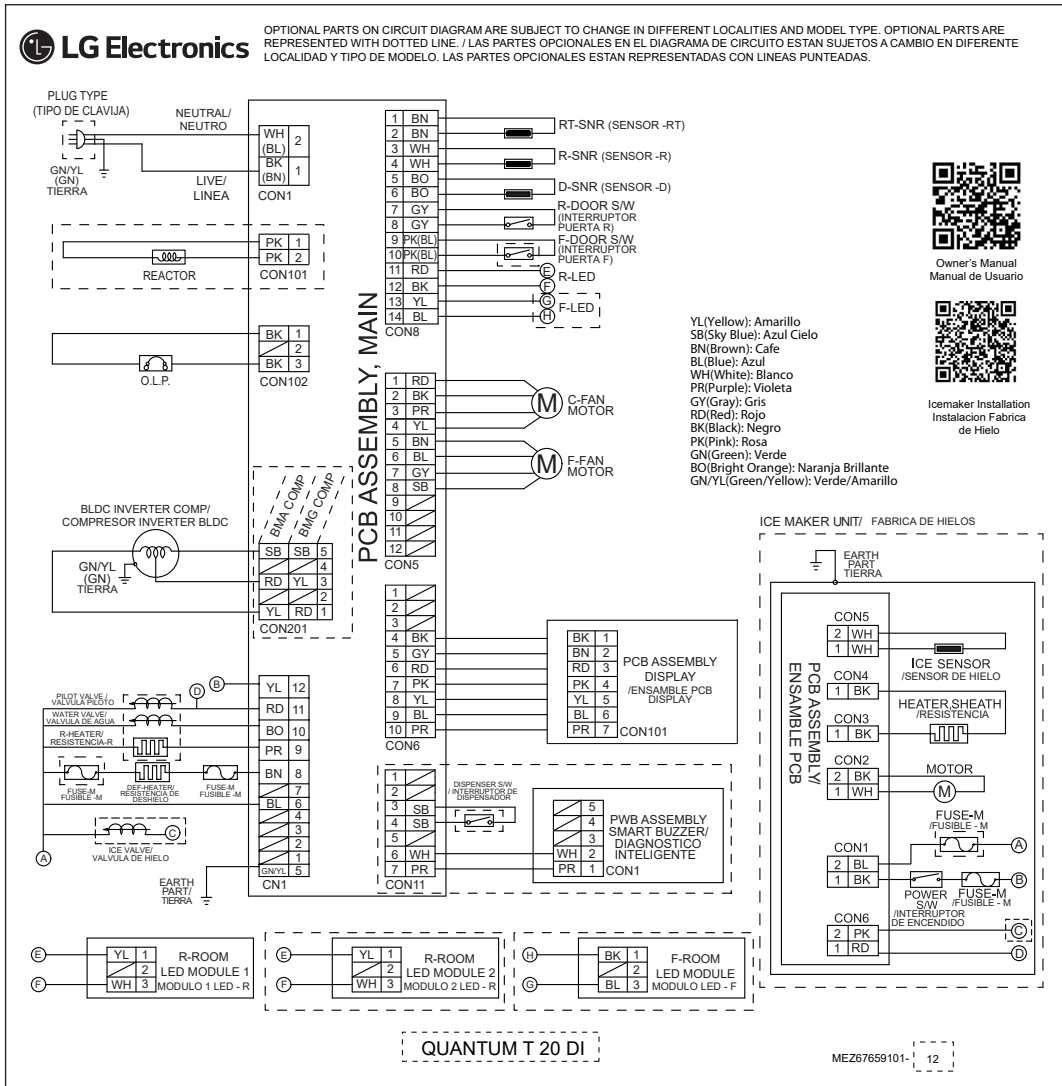

7. TROUBLESHOOTING

7-1. COMPRESSOR AND ELECTRIC COMPONENTS

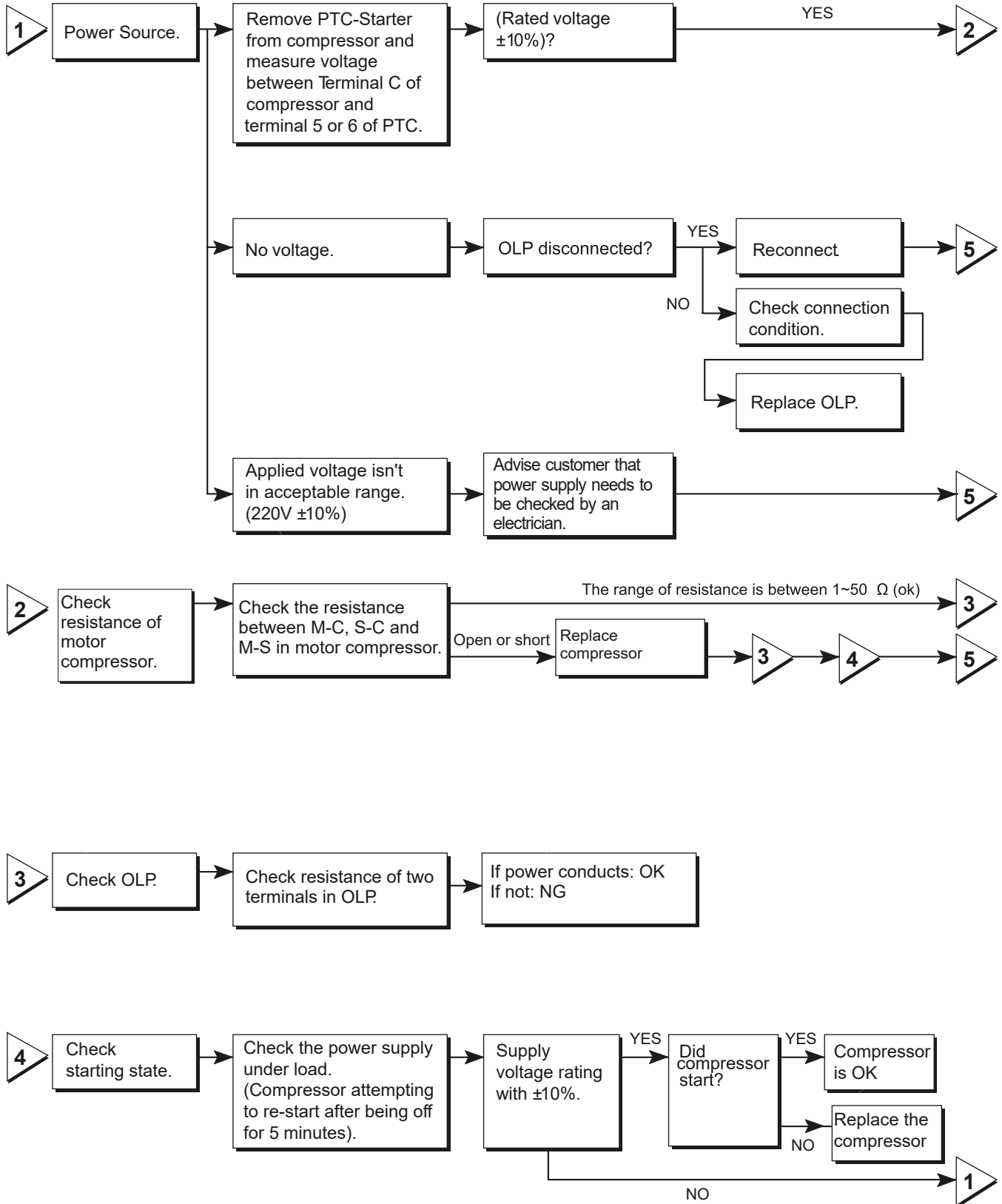

7-2 OLP

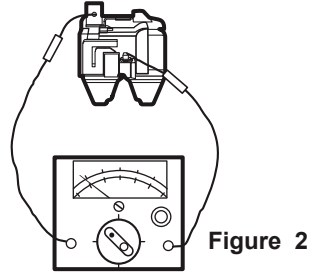
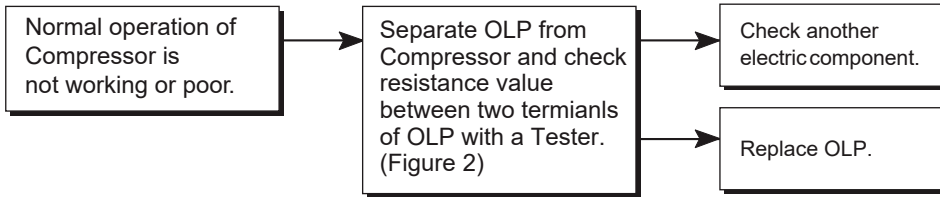

7-3 OTHER ELECTRIC COMPONENTS

• Not cooling at all

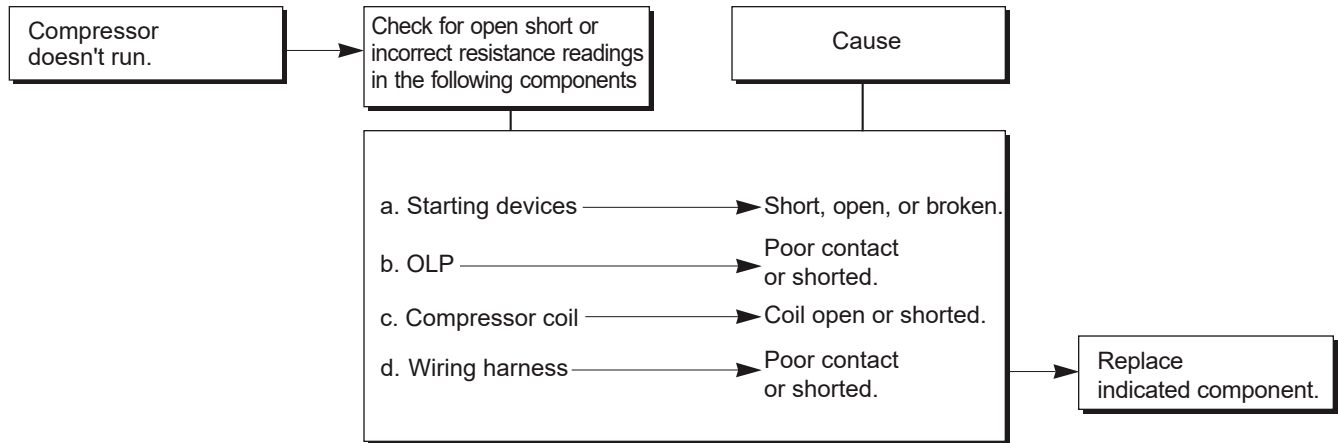

Poor cooling performance

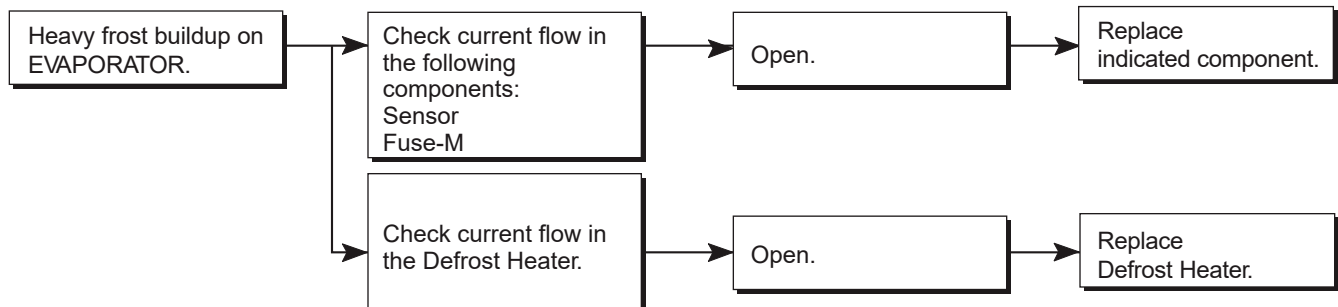
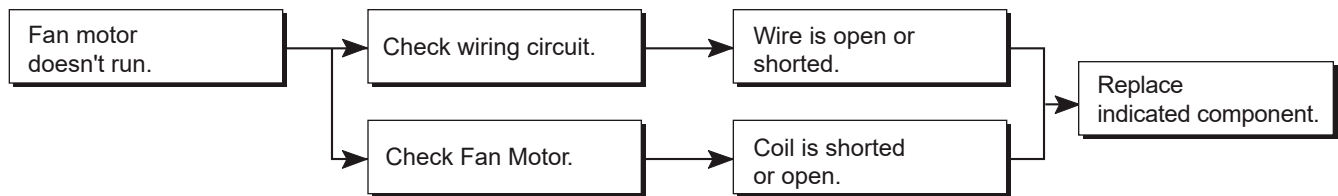
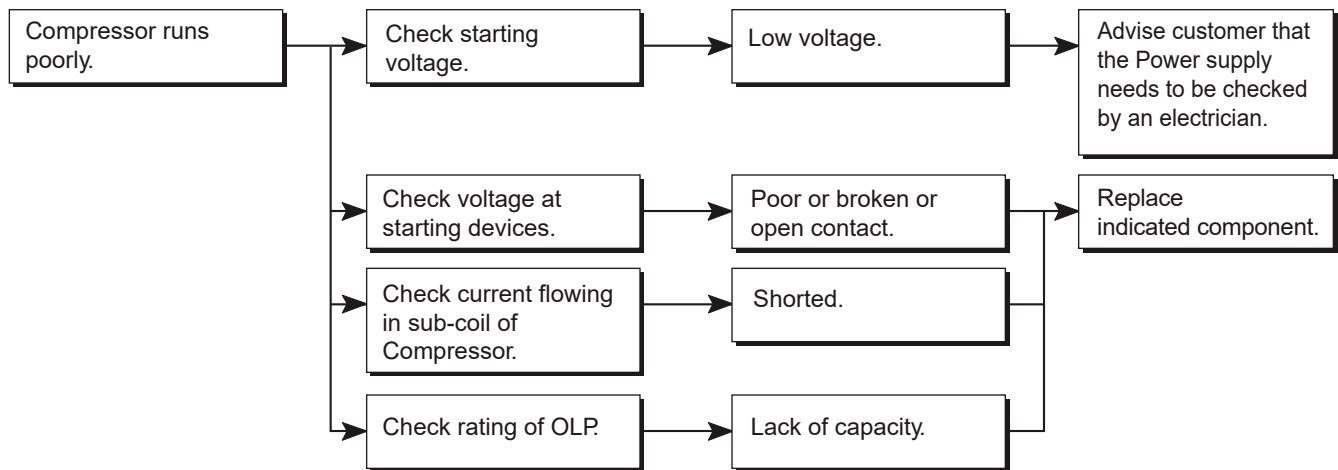

7-4 SERVICE DIAGNOSIS CHART

COMPLAINT	SYMPTOM	POSSIBLE CAUSES	SOLUTION
Electronic Display not operating correctly	1. No Display at all	<ol style="list-style-type: none"> 1. Supply voltage not within specifications 2. Open in wiring harness from PWB board 3. Open in door monitor switch circuit 	<ol style="list-style-type: none"> 1. Check supply voltage to refrigerator 2. Check wiring and connectors to PCB board 3. Check door monitor circuit
	2. Partial or abnormal display	<ol style="list-style-type: none"> 1. Supply voltage not within specifications 2. Open wiring harness from PWB board 	<ol style="list-style-type: none"> 1. Check supply voltage to refrigerator 2. Check wiring and connectors to PCB board
Not cooling	1. Display on but compressor not operating	<ol style="list-style-type: none"> 1. Compressor not operating 2. Open in compressor circuit 	<ol style="list-style-type: none"> 1. Check for compressor operation by using the test key on main circuit board. 2. Check for open on OLP, PTC, compressor, wiring, etc
Not cold enough	1. Display on compressor is operating	<ol style="list-style-type: none"> 1. Condenser fan motor not operating 2. Condenser coils blocked 3. Evaporator fan motor not operating 4. Internal air flow blocked 5. Sensor not operating properly 6. Door not sealing 7. Evaporator frosted up 8. Sealed system related problem 	<ol style="list-style-type: none"> 1. Check condenser fan motor and wiring circuit 2. Check air flow across condenser 3. Check evaporator fan motor and wiring circuit 4. Check air ducts 5. Check refrigerator and freezer sensors 6. Check for proper door seal 7. Check defrost circuit components
Not defrosting	1. Freezer has too much frost	<ol style="list-style-type: none"> 1. Open in defrost circuit 2. Defrost sensor not operating correctly 3. Defrost drain clogged 	<ol style="list-style-type: none"> 1. Check defrost heater and circuit using Test Key 2. Check sensor 3. Check drain

7-5 REFRIGERATING CYCLE

• Troubleshooting Chart

CAUSE		STATE OF THE UNIT	STATE OF THE EVAPORATOR	TEMPERATURE OF THE COMPRESSOR	REMARKS
LEAKAGE	PARTIAL LEAKAGE	Freezer compartment and Refrigerator don't cool normally.	Low flowing sound of Refrigerant is heard and frost forms in inlet only.	A little higher than ambient temperature.	<ul style="list-style-type: none"> Refrigerant level is low due to a leak. Normal cooling is possible by restoring the normal amount of Refrigerant and repairing the leak.
	COMPLETE LEAKAGE	Freezer compartment and Refrigerator don't cool normally.	Flowing sound of refrigerant is not heard and frost isn't formed.	Equal to ambient temperature.	<ul style="list-style-type: none"> No discharging of Refrigerant. Normal cooling is possible by restoring the normal amount of refrigerant and repairing the leak.
RESTRICTEDBYDUST	PARTIAL RESTRICTION	Freezer compartment and Refrigerator don't cool normally.	Flowing sound of refrigerant is heard and frost forms in inlet only.	A little higher than ambient temperature.	<ul style="list-style-type: none"> Normal discharging of the refrigerant. The capillary tube is faulty.
	WHOLE RESTRICTION	Freezer compartment and Refrigerator don't cool.	Flowing sound of refrigerant is not heard and frost isn't formed.	Equal to ambient temperature.	<ul style="list-style-type: none"> Normal discharging of the refrigerant.
MOISTURE RESTRICTION		Cooling operation stops periodically.	Flowing sound of refrigerant is not heard and frost melts.	Lower than ambient temperature.	<ul style="list-style-type: none"> Cooling operation restarts when heating the inlet of the capillary tube.
DEFECTIVE COMPRESSION	COMP-RESSION	Freezer and Refrigerator don't cool.	Low flowing sound of refrigerant is heard and frost forms in inlet only.	A little higher ambient temperature.	<ul style="list-style-type: none"> Low pressure at high side of compressor due to low refrigerant level.
	NO COMP-RESSION	No compressing operation.	Flowing sound of refrigerant is not heard and there is no frost.	Equal to ambient temperature.	<ul style="list-style-type: none"> No pressure in the high pressure part of the compressor.

Leakage Detection

Check sealed system for leak.

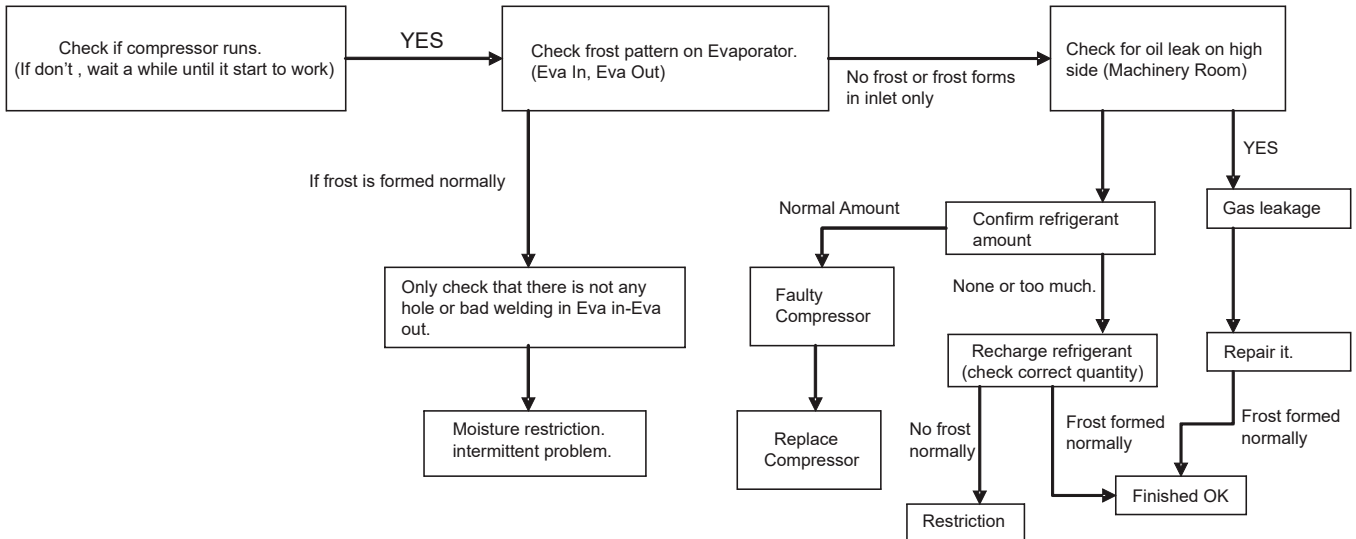

8. CIRCUIT OF MICOM

8-1 FUNCTION

8-1-1 Function

1. When Appliance is plugged in for first time, is set "middle" for the refrigerator. You can adjust the refrigerator control temperature by pressing the Temperature Adjust button.
2. When the power is initially applied or restored a power failure, it is set at the last control temperature selected before the power initially applied or restored a power failure.

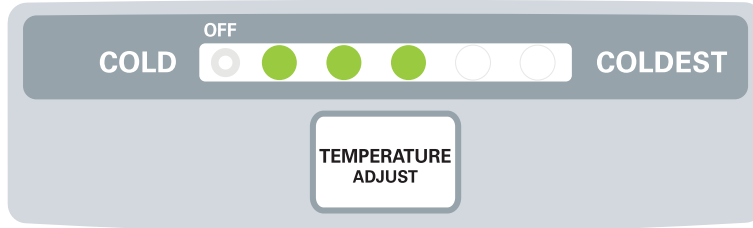

8-1-2 Defrost Cycle

Defrosting starts each time the accumulated COMPRESSOR running time is between 7 and 50 hours. This time is determinate by how long the doors are opened.

For initial power on or for restoring power, defrosting starts when the compressor running time reaches 4 hours.

Defrosting stops if the sensor temperature reaches 50 °F (10 °C) or more. If the sensor doesn't reach the 50 °F (10°C) in 1 hour, the defrost mode is malfunctioning. (Refer to the defect diagnosis function).

Defrosting won't function if the sensor is defective (wires are cut or short circuited)

8-1-3 Electrical Parts Operation in Sequence.

Electrical parts such as COMP, defrost heater, freezer FAN, etc. Operate in the following order to prevent noise and parts damage. Several parts are started at the same time at initial power on and are turned off together when TEST is completed.

OPERATING		ORDER	REMARKS
INITIAL POWER ON	Temperature of defrost sensor is 113°F (45°C) or more .	<pre> graph LR A[POWER ON] -- 0.5 Sec --> B[COMP, F-FAN ON] </pre>	
	Temperature of defrost sensor is lower than 113°F (45°C).	<pre> graph LR A[POWER ON] -- 0.5 Sec --> B[Def-Heater ON] B -.- 10 Sec --> C[Def-Heater OFF] A -- 0.5 Sec --> D[COMP, F-FAN ON] </pre>	

(ON : ● / OFF : ○)

Temp Control	OFF Mode	Low	Medium/ Low	Medium	Medium/ High	High
TEMP(°C)	○○○○○	○●○○○○	○●●○○○	○●●●○○	○●●●●○	○●●●●●
R	REFRIGERATOR					

8-1-4 CONTROL OF FAN IN THE FREEZER COMPARTMENT

1. When the freezer or refrigerator door is opened, the Freezer Fan ON, but if door not close within 1 min. then freezer fan turn off.
- 2.- Freezer fan is turn on when compressor is operating or TEST MODE 1 is activate.
- 3.- Freezer fan not working when defrosting is operating or TEST MODE 2 is activate.

8-1-5 ALARM FOR OPEN DOOR

1. This feature is to alarm by the buzzer when the door of the freezer or the refrigerator is not closed in 1 minute after it is opened.
2. In 1 minute after the door is opened, the buzzer sounds three times at the interval of 0.5 second. After that, every 30 seconds, the buzzer sounds three times with 0.5 sec ON/OFF.
3. The alarming is cancelled when the door of the freezer or the refrigerator is closed while the buzzer sounds.

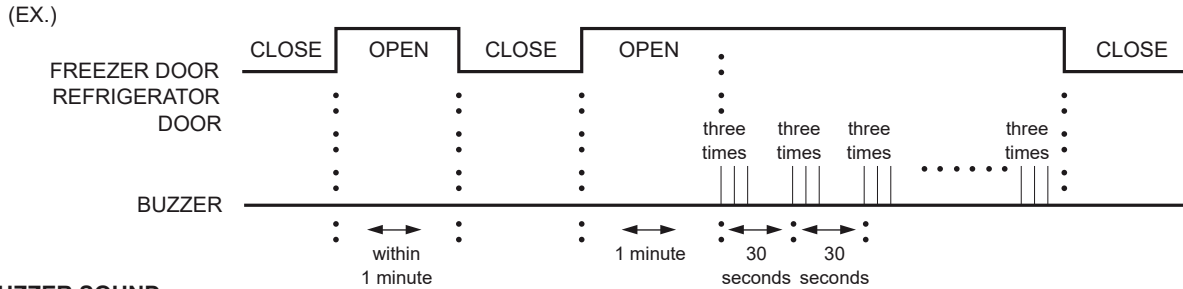

8-1-6 BUZZER SOUND

1. When the button on the front Display is pushed, "Ding-" sound is produced and it works as follows.

8-1-7 DEFROSTING

1. Defrosting starts each time the compressor running time reaches between 7~50 hours and 50 hours according to door open time.
2. For initial power on or for restoring power, defrosting starts when the compressor running time reaches 4 hours.
3. Defrosting stops if the sensor temperature reaches 10°C or more. If the sensor doesn't reach 10°C in 2 hours, the defrost mode is malfunctioning.
4. Defrosting won't function if its sensor is defective (wires are cut or short circuited)

8-1-8 SEQUENTIAL OPERATION OF ELECTRIC COMPONENTS

The electric components, such as the comp, defrosting heater, and cooling fan, start sequentially to avoid the noise and damage to the part, which may result from the simultaneous start of various components on turning the power on or after the completion of a test.

OPERATING	ORDER	REMARKS
INITIAL POWER ON Temperature of defrost sensor is 113°F (45°C) or more .	<pre> graph LR A[POWER ON] -- 0.5 Sec --> B[COMP, F-FAN ON] </pre>	
INITIAL POWER ON Temperature of defrost sensor is lower than 113°F (45°C).	<pre> graph LR A[POWER ON] -- 0.5 Sec --> B[Def-Heater ON] B -.- 5 Sec --> C[Def-Heater OFF] C --> D[COMP, F-FAN ON] A -- 10 Sec --> D </pre>	

8-1-9 ERROR DIAGNOSTIC MODE

1. The error diagnostic mode allows the SVC when a fault that may affect the performance of the product occurs while operating the product.
2. Even if the function control button is pushed when an error occurs, the function will not be performed.
3. When the error is cleared while the error is detected, the appliance returns to the normal condition (Reset).
4. The error code is displayed by the refrigerator temp indication LED on the display of the refrigerator while the remaining LEDs are off.

Note) All of the errors except room temperature sensor error are displayed only after 3 hours after sensing the error. To check if an error has occurred before 3 hours have passed, press and hold down TEMP AJUST button.

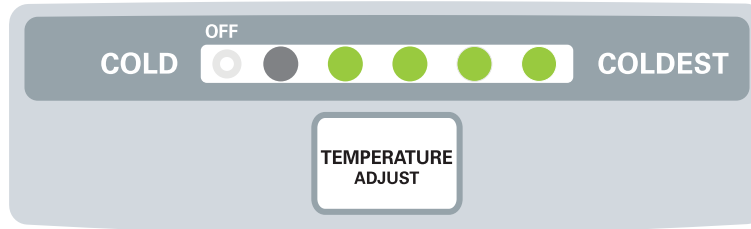

• ERROR CODE on Refrigerator Temperature panel

● ON ● OFF

NO	Item	Error Code					Contents	Product Operation Status in Failure		
		R1	R2	R3	R4	R5		Compressor	Freezer Motor	Defrost Heater
1	Failure of Refrigerator . Sensor	OFF	●	●	●	●	Ref. Sensor Open or Short circuit wire	15min ON/ 15 min OFF	15min ON/ 15 min OFF	Normal
2	Failure of Defrost Sensor	OFF	●	●	●	●	Defrost Sensor Open or Short circuit wire	Normal	Normal	No defrost
3	Failure of Room Temperature Sensor	OFF	●	●	●	●	RT Sensor Open or Short circuit wire	Normal	Normal	Normal
4	Failure of Defrost mode	OFF	●	●	●	●	When defrosting sensor do not reach reach 50°F (10°C) within 1Hr after starting Defrost	Normal	Normal	Normal
5	Failure of Fan Motor at freezer Compartment	OFF	●	●	●	●	If there is not motor Signal (motor could be locked)	Normal	OFF	Normal
6	Failure of Fan Motor at mechanic room	OFF	●	●	●	●	If there is not motor signal (motor could be locked)	Normal	Normal	Normal

8-1-12 TEST MODE

1. The test mode allows checking the PCB and the function of the product as well as finding out the defective part in case of an error.
2. The test button is on the main PCB of the refrigerator (Test S/W). The test mode will be cleared in 5 minutes on test mode 1 and in 2 hours on test mode 2 and then reset.
3. While in the test mode, the function control button is not recognized though the recognition tone (beep~) sounds.
4. After exiting the test mode, be sure reset by unplugging and then plugging in the appliance.
5. If an error, such as a sensor failure, is detected while in the test mode, the test mode is cleared and the error code is displayed.
6. While an error is detected, the test mode will not be activated even if the test button is pushed.

e d o M n o i t a l u p i n a M t n e t n o C k r a m e R			
TEST 1	Push the test button once.	<ol style="list-style-type: none"> 1. Continuous operation of the comp 2. Continuous operation of the freezer fan 3. Defrosting heater OFF 4. Every display LED ON 5. Room lighting LEDs can be switch on/off by door open 	
TEST 2	Push the test button once while in the TEST MODE 1.	<ol style="list-style-type: none"> 1. Comp OFF 2. Freezer fan OFF 3. Defrosting heater ON 4. Temperature display part show as bellows. 	Reset if the temp of the defrosting sensor is 10°C or above.
Reset	Push the test button once while in the TEST MODE 2.	Reset to the default setting	The compressor will start in 7 minute-delay. The freezer fan will start in 12 minute-delay.

* LED Check Mode: When the ADJUST TEMP button is pushed and held together for 1 sec or longer, every LED on the display turns on simultaneously or error code is shown if any error is detected. When the buttons are released, the previous mode is restored.

<TEST MODE1 STATUS LED>

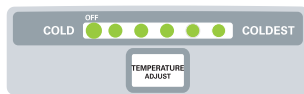

<TEST MODE2 STATUS LED>

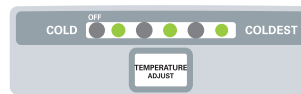

Demonstration MODE (OFF)

1. Press the temperature Adjust button until the OFF LED turns ON to activate this mode. (After selecting the Demonstration Mode it takes 10 seconds to be enable).
2. In this status all loads are OFF (Compressor, Fans, Heaters), only LED lamp will be in normal function.
3. To exit of the Demonstration Mode press the Temperature Adjust button and set the desired temperature level. The device will reset after 10 seconds and the display will blink one time.

Note: If door is opened within the first 5 minutes from power on the demonstration mode, it will be released and set at middle level automatically.

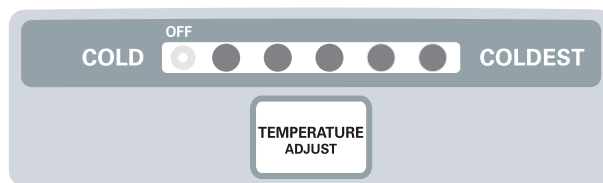

9. SMART DIAGNOSIS & DOOR ALARM

1. PCB Picture

- 1) Main PCB
- 2) Display PCB
- 3) LED Lighting

2. Troubleshooting

- 1) RT Sensor Error
- 2) Refrigerator Sensor Error
- 3) Defrost Sensor Error
- 4) Defrost Error
- 5) Water Dispenser not working
- 6) Freezer Room LED Module doesn't work
- 7) Refrigerator Room LED Module doesn't work
- 8) Poor cooling in Refrigerator room
- 9) Over cooling in Refrigerator room
- 10) Freezer BLDC FAN Motor Error
- 11) Cooling BLDC FAN Motor Error

3. Reference

- 1) Temperature compensation
- 2) TEST MODE and Removing TPA
- 3) TEMPERATURE CHART - REF AND DEFROST SENSOR
- 4) TEMPERATURE CHART - RT SENSOR

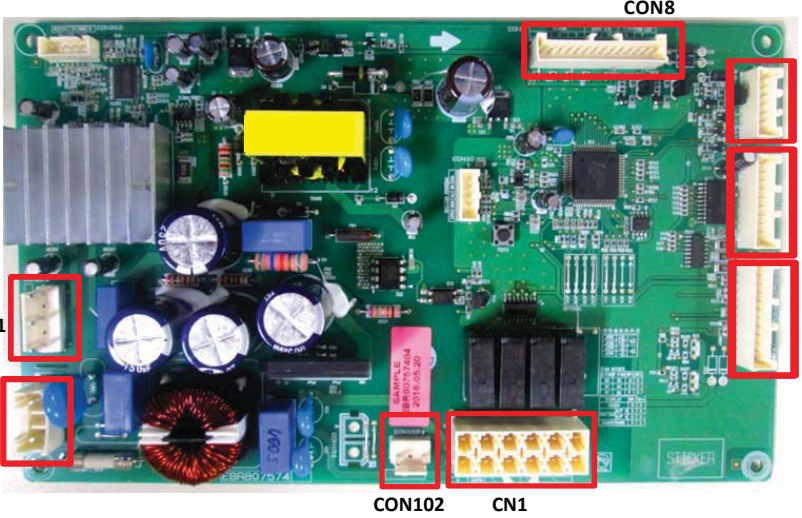
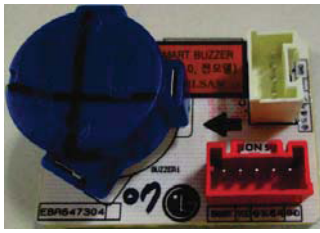

1-1. MAIN PCB

Part Name	Picture
<p>1. MAIN PCB</p>	<p>EBR807574**</p> <p>220V</p>  <p>NOTES</p> <ul style="list-style-type: none"> - CON 1 : Power Supply - CON 2 : AC Load - CON 5 : C-FAN,F-FAN, Hygiene(Optional), - CON 6 : Tactile Display or Inner Display PCB - CON 8 : Sensors, LED Lightning and door switch. - CON 10,CON 202 : Programming Port - CON 11: Dispenser Switch, Smart Buzzer(Optional) and Dispenser LED(Optional) - CON201 : OLP <p>Optional Connectors</p> <ul style="list-style-type: none"> - CON 7 : Touch Display PCB - CON 9: Ice Maker twisting
<p>2. BOARD SYSTEM DIAGNOSIS INTELLIGENT (SDS)</p>	<p>P/N: EBR64730407</p> 

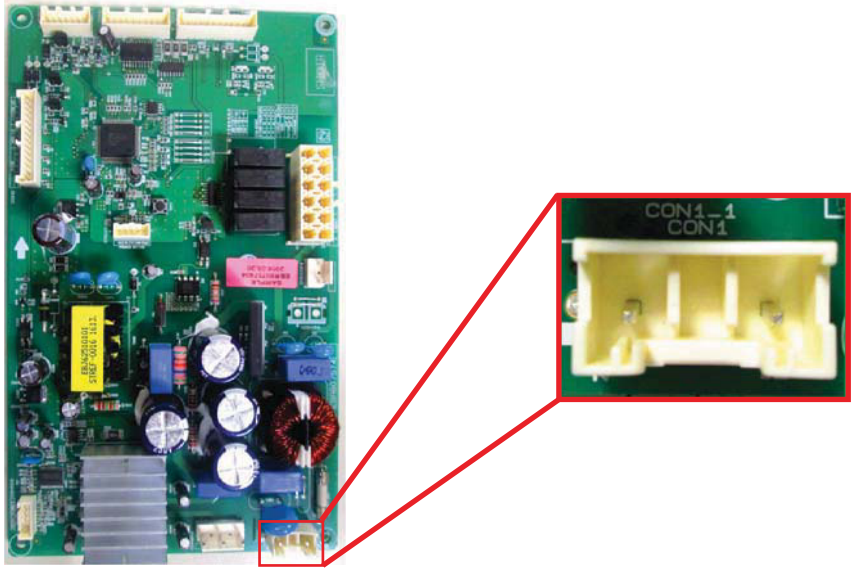
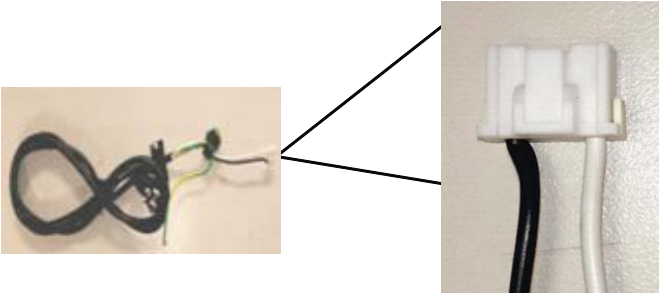
1-1. MAIN PCB

Part Name	Picture
<p>PCB PJT QT 20 (220-230V)</p>	<p>P/N: EBR807574**</p>  <p>The image shows a green printed circuit board (PCB) populated with various electronic components including capacitors, resistors, and integrated circuits. A red rectangular callout box highlights a specific connector on the board. A larger, magnified view of this connector is shown to the right, revealing a yellow plastic housing with two metal pins. The text 'CON1-1' and 'CON1' is visible on the board above the connector.</p>
<p>Power Cord PJT Plug C4 (220V)</p>	<p>P/N: EAD61445250</p>  <p>The image shows a black power cord with a white plastic plug. A callout box highlights the plug, showing a close-up of its two prongs and the internal wiring connections.</p>

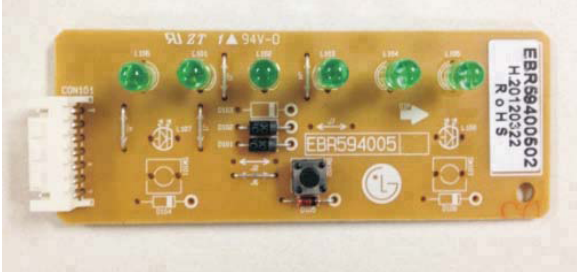
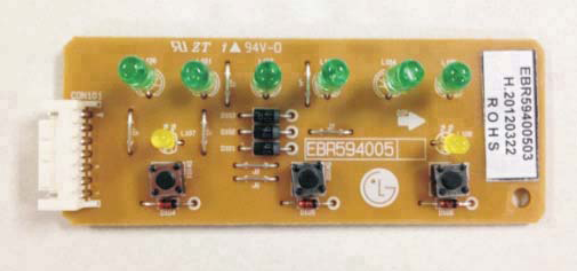
1-2. DISPLAY PCB & LED Lighting

e m	a N t r a P	e r u t c i P
<p>Basic Models Tact and Inner Display</p>	<p>P/N: EBR59400502</p>  <p>The image shows a yellow PCB with six green LEDs, a central microcontroller, and various passive components. A white label on the right side contains the part number EBR59400502, date code H.20120322, and R.O.H.S. The PCB also features a connector on the left and a circular logo on the right.</p>	
<p>Dispenser Models Tact and Inner Display</p>	<p>P/N: EBR59400503</p>  <p>The image shows a yellow PCB similar to the previous one, but with two yellow LEDs instead of green. The white label on the right side contains the part number EBR59400503, date code H.20120322, and R.O.H.S. The PCB also features a connector on the left and a circular logo on the right.</p>	
<p>R-Room LED Module</p>	<p>P/N: ACQ89591801</p>  <p>The image shows a long, thin LED module with several small LEDs mounted on a white substrate. A small label on the right side contains the part number ACQ89591801.</p>	

1) RT Sensor Error

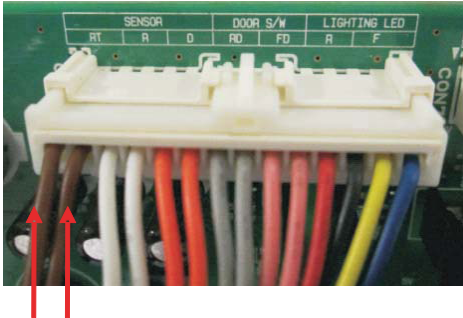

No	w o l f g n i k c e h C n o i t c A C V																																																						
1	<p>Check for loose connection in CON8.</p>	<table border="1"> <thead> <tr> <th colspan="2">Result</th> <th>SVC Action</th> </tr> </thead> <tbody> <tr> <td>Firmly plugged</td> <td></td> <td>Go to step 2</td> </tr> <tr> <td>Loose</td> <td></td> <td>Plug firmly then check again. Problem persist? YES: Go to step 2. NO: Explain to customer.</td> </tr> </tbody> </table>	Result		SVC Action	Firmly plugged		Go to step 2	Loose		Plug firmly then check again. Problem persist? YES: Go to step 2. NO: Explain to customer.																																												
		Result		SVC Action																																																			
Firmly plugged		Go to step 2																																																					
Loose		Plug firmly then check again. Problem persist? YES: Go to step 2. NO: Explain to customer.																																																					
2	<p>1.- Unplug connector from CON8. 2.- Check resistance in wires Brown to Brown.</p>  <p>3.- Plug in CON8, check voltage in wires Brown to Brown, and check voltage and temperature result in Table-3)</p> 	<table border="1"> <thead> <tr> <th colspan="2">Result</th> <th>SVC Action</th> </tr> </thead> <tbody> <tr> <td>0 Ω</td> <td>Short</td> <td>Change the sensor</td> </tr> <tr> <td>Infinte ohms</td> <td>Open</td> <td>Check the resistance of the sensor wires back to the main PCB. if they are open between the main PCB and connector it will be necessary to replace the refrigerator</td> </tr> <tr> <td>Other</td> <td>Normal</td> <td>Check the Temp and resistance (Table-3)</td> </tr> </tbody> </table>	Result		SVC Action	0 Ω	Short	Change the sensor	Infinte ohms	Open	Check the resistance of the sensor wires back to the main PCB. if they are open between the main PCB and connector it will be necessary to replace the refrigerator	Other	Normal	Check the Temp and resistance (Table-3)																																									
		Result		SVC Action																																																			
		0 Ω	Short	Change the sensor																																																			
Infinte ohms	Open	Check the resistance of the sensor wires back to the main PCB. if they are open between the main PCB and connector it will be necessary to replace the refrigerator																																																					
Other	Normal	Check the Temp and resistance (Table-3)																																																					
<p><Temperature table-3></p> <table border="1"> <thead> <tr> <th>TEMP</th> <th>RESISTANCE</th> <th>VOLTAGE</th> </tr> </thead> <tbody> <tr><td>-39°F (-40°C)</td><td>225.1 kΩ</td><td>4.48 V</td></tr> <tr><td>-30°F (-35°C)</td><td>169.8 kΩ</td><td>4.33 V</td></tr> <tr><td>-21°F (-30°C)</td><td>129.3 kΩ</td><td>4.641 V</td></tr> <tr><td>-13°F (-25°C)</td><td>99.30 kΩ</td><td>4.54 V</td></tr> <tr><td>-4°F (-20°C)</td><td>76.96 kΩ</td><td>4.425 V</td></tr> <tr><td>5°F (-15°C)</td><td>60.13 kΩ</td><td>4.287 V</td></tr> <tr><td>14°F (-10°C)</td><td>47.34 kΩ</td><td>4.128 V</td></tr> <tr><td>23°F (-5°C)</td><td>37.55 kΩ</td><td>3.948 V</td></tr> <tr><td>32°F (0°C)</td><td>30 kΩ</td><td>3.75 V</td></tr> <tr><td>41°F (+5°C)</td><td>24.13 kΩ</td><td>3.535 V</td></tr> <tr><td>50°F (+10°C)</td><td>19.53 kΩ</td><td>3.307 V</td></tr> <tr><td>59°F (+15°C)</td><td>15.91 kΩ</td><td>3.070V</td></tr> <tr><td>68°F (+20°C)</td><td>13.03 kΩ</td><td>2.829 V</td></tr> <tr><td>77°F (+25°C)</td><td>10.74 kΩ</td><td>2.589 V</td></tr> <tr><td>86°F (+30°C)</td><td>8.89 kΩ</td><td>2.354 V</td></tr> <tr><td>95°F (+35°C)</td><td>7.40 kΩ</td><td>2.128V</td></tr> <tr><td>104°F (+40°C)</td><td>6.20kΩ</td><td>1.914 V</td></tr> </tbody> </table>		TEMP	RESISTANCE	VOLTAGE	-39°F (-40°C)	225.1 kΩ	4.48 V	-30°F (-35°C)	169.8 kΩ	4.33 V	-21°F (-30°C)	129.3 kΩ	4.641 V	-13°F (-25°C)	99.30 kΩ	4.54 V	-4°F (-20°C)	76.96 kΩ	4.425 V	5°F (-15°C)	60.13 kΩ	4.287 V	14°F (-10°C)	47.34 kΩ	4.128 V	23°F (-5°C)	37.55 kΩ	3.948 V	32°F (0°C)	30 kΩ	3.75 V	41°F (+5°C)	24.13 kΩ	3.535 V	50°F (+10°C)	19.53 kΩ	3.307 V	59°F (+15°C)	15.91 kΩ	3.070V	68°F (+20°C)	13.03 kΩ	2.829 V	77°F (+25°C)	10.74 kΩ	2.589 V	86°F (+30°C)	8.89 kΩ	2.354 V	95°F (+35°C)	7.40 kΩ	2.128V	104°F (+40°C)	6.20kΩ	1.914 V
TEMP	RESISTANCE	VOLTAGE																																																					
-39°F (-40°C)	225.1 kΩ	4.48 V																																																					
-30°F (-35°C)	169.8 kΩ	4.33 V																																																					
-21°F (-30°C)	129.3 kΩ	4.641 V																																																					
-13°F (-25°C)	99.30 kΩ	4.54 V																																																					
-4°F (-20°C)	76.96 kΩ	4.425 V																																																					
5°F (-15°C)	60.13 kΩ	4.287 V																																																					
14°F (-10°C)	47.34 kΩ	4.128 V																																																					
23°F (-5°C)	37.55 kΩ	3.948 V																																																					
32°F (0°C)	30 kΩ	3.75 V																																																					
41°F (+5°C)	24.13 kΩ	3.535 V																																																					
50°F (+10°C)	19.53 kΩ	3.307 V																																																					
59°F (+15°C)	15.91 kΩ	3.070V																																																					
68°F (+20°C)	13.03 kΩ	2.829 V																																																					
77°F (+25°C)	10.74 kΩ	2.589 V																																																					
86°F (+30°C)	8.89 kΩ	2.354 V																																																					
95°F (+35°C)	7.40 kΩ	2.128V																																																					
104°F (+40°C)	6.20kΩ	1.914 V																																																					

2) Refrigerator Sensor Error

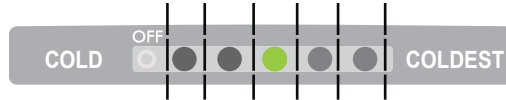

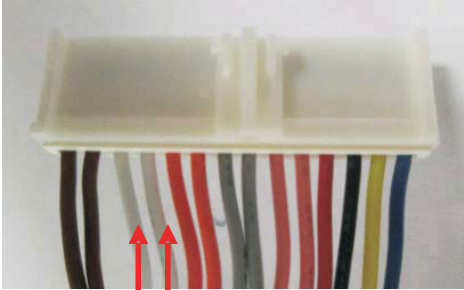
No	Checking Flow	Result & SVC Action																								
1	Check for loose connection in CON8.	<table border="1"> <thead> <tr> <th>Result</th> <th>SVC Action</th> </tr> </thead> <tbody> <tr> <td>Firmly plugged</td> <td>Go to step 2</td> </tr> <tr> <td>Loose</td> <td>Plug firmly, then check again. Problem persist? YES: Go to step 2. NO: Explain to customer.</td> </tr> </tbody> </table>	Result	SVC Action	Firmly plugged	Go to step 2	Loose	Plug firmly, then check again. Problem persist? YES: Go to step 2. NO: Explain to customer.																		
Result	SVC Action																									
Firmly plugged	Go to step 2																									
Loose	Plug firmly, then check again. Problem persist? YES: Go to step 2. NO: Explain to customer.																									
2	<p>1.- Unplug connector from CON8. 2.- Check resistance in wires <u>White to White</u>.</p> 	<table border="1"> <thead> <tr> <th colspan="2">Result</th> <th>SVC Action</th> </tr> </thead> <tbody> <tr> <td>0 Ω</td> <td>Short</td> <td>Change the sensor</td> </tr> <tr> <td>Infinite ohms</td> <td>Open</td> <td>Check the resistance of the sensor wires back to the main PCB. if they are open between the main PCB and connector it will be necessary to replace the refrigerator</td> </tr> <tr> <td>Other</td> <td>Normal</td> <td>Check the Temp and resistance (Table-1)</td> </tr> </tbody> </table> <p style="text-align: center;"><Temperature table-1></p> <table border="1"> <thead> <tr> <th>(1) To (2)</th> <th>Result</th> </tr> </thead> <tbody> <tr> <td>23°F / -5°C</td> <td>38 kΩ</td> </tr> <tr> <td>32°F / 0°C</td> <td>30 kΩ</td> </tr> <tr> <td>41°F / 5°C</td> <td>24 kΩ</td> </tr> <tr> <td>50°F / 10°C</td> <td>19.5 kΩ</td> </tr> <tr> <td>59°F / 15°C</td> <td>16 kΩ</td> </tr> </tbody> </table> <p>※ The sensor is determined by the temperature. For example, 30 kΩ indicates 32°F.</p>	Result		SVC Action	0 Ω	Short	Change the sensor	Infinite ohms	Open	Check the resistance of the sensor wires back to the main PCB. if they are open between the main PCB and connector it will be necessary to replace the refrigerator	Other	Normal	Check the Temp and resistance (Table-1)	(1) To (2)	Result	23°F / -5°C	38 kΩ	32°F / 0°C	30 kΩ	41°F / 5°C	24 kΩ	50°F / 10°C	19.5 kΩ	59°F / 15°C	16 kΩ
Result		SVC Action																								
0 Ω	Short	Change the sensor																								
Infinite ohms	Open	Check the resistance of the sensor wires back to the main PCB. if they are open between the main PCB and connector it will be necessary to replace the refrigerator																								
Other	Normal	Check the Temp and resistance (Table-1)																								
(1) To (2)	Result																									
23°F / -5°C	38 kΩ																									
32°F / 0°C	30 kΩ																									
41°F / 5°C	24 kΩ																									
50°F / 10°C	19.5 kΩ																									
59°F / 15°C	16 kΩ																									

3) Defrost Sensor Error

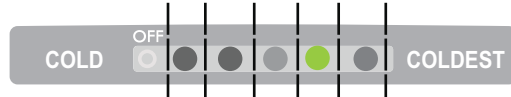

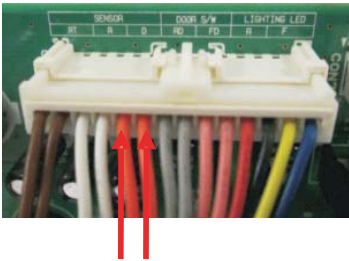
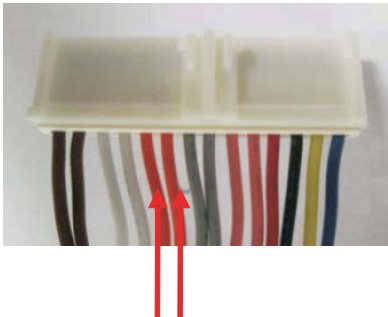
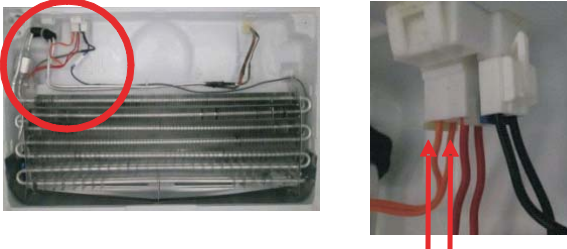
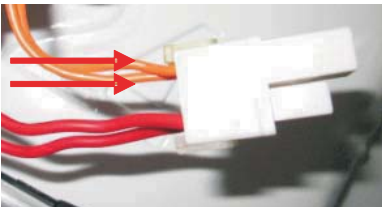

No	Checking flow	Result & SVC Action												
1	<p>Check for loose connection in CON8.</p> 	<table border="1"> <thead> <tr> <th>Result</th> <th>SVC Action</th> </tr> </thead> <tbody> <tr> <td>Firmly plugged</td> <td>Go to step 2</td> </tr> <tr> <td>Loose</td> <td>Plug firmly, then check again. Problem persist? YES: Go to step 2. NO: Explain to customer.</td> </tr> </tbody> </table>	Result	SVC Action	Firmly plugged	Go to step 2	Loose	Plug firmly, then check again. Problem persist? YES: Go to step 2. NO: Explain to customer.						
Result	SVC Action													
Firmly plugged	Go to step 2													
Loose	Plug firmly, then check again. Problem persist? YES: Go to step 2. NO: Explain to customer.													
2	<p>1.- Unplug connector from CON8. 2.- Check resistance in wires <u>Orange to Orange.</u></p> 	<table border="1"> <thead> <tr> <th colspan="2">Result</th> <th>SVC Action</th> </tr> </thead> <tbody> <tr> <td>0 Ω</td> <td>Short</td> <td>Change the sensor</td> </tr> <tr> <td>Infinite ohms</td> <td>Open</td> <td>Check the resistance of the sensor wires back to the main PCB. if they are open between the main PCB and connector it will be necessary to replace the refrigerator</td> </tr> <tr> <td>Other</td> <td>Normal</td> <td>Check the Temp and resistance (Table-2)</td> </tr> </tbody> </table>	Result		SVC Action	0 Ω	Short	Change the sensor	Infinite ohms	Open	Check the resistance of the sensor wires back to the main PCB. if they are open between the main PCB and connector it will be necessary to replace the refrigerator	Other	Normal	Check the Temp and resistance (Table-2)
Result		SVC Action												
0 Ω	Short	Change the sensor												
Infinite ohms	Open	Check the resistance of the sensor wires back to the main PCB. if they are open between the main PCB and connector it will be necessary to replace the refrigerator												
Other	Normal	Check the Temp and resistance (Table-2)												
3	<p>Check for loose connection in evaporator heater connector.</p> 	<p style="text-align: center;"><Temperature table-1></p> <table border="1"> <thead> <tr> <th>(1) To (2)</th> <th>Result</th> </tr> </thead> <tbody> <tr> <td>23°F / -5°C</td> <td>38 kΩ</td> </tr> <tr> <td>32°F / 0°C</td> <td>30 kΩ</td> </tr> <tr> <td>41°F / 5°C</td> <td>24 kΩ</td> </tr> <tr> <td>50°F / 10°C</td> <td>19.5 kΩ</td> </tr> <tr> <td>59°F / 15°C</td> <td>16 kΩ</td> </tr> </tbody> </table>	(1) To (2)	Result	23°F / -5°C	38 kΩ	32°F / 0°C	30 kΩ	41°F / 5°C	24 kΩ	50°F / 10°C	19.5 kΩ	59°F / 15°C	16 kΩ
(1) To (2)	Result													
23°F / -5°C	38 kΩ													
32°F / 0°C	30 kΩ													
41°F / 5°C	24 kΩ													
50°F / 10°C	19.5 kΩ													
59°F / 15°C	16 kΩ													
4	<p>1.- Unplug evaporator heater connector . 2.- Check resistance in wires <u>Orange to Orange.</u></p> 	<p>※ The sensor is determined by the temperature. For example, 30kΩ indicates 32°F.</p>												

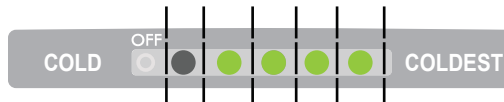
4) Defrost Error

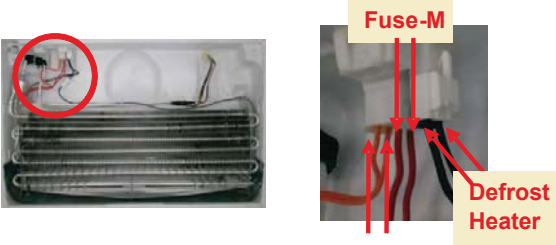
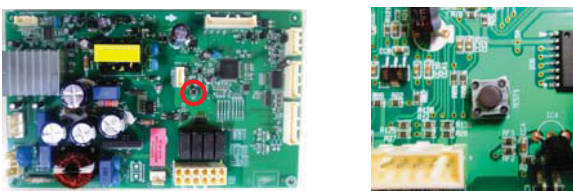
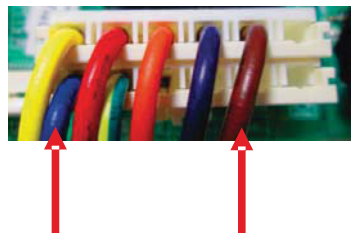
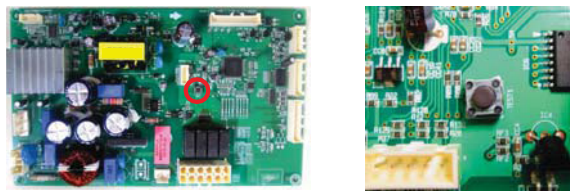
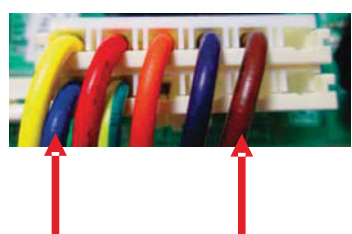

No	Checking flow	Result & SVC Action																		
1	Check the <u>Door Gasket</u> .	<table border="1"> <thead> <tr> <th>Part</th> <th>Result</th> <th>SVC Action</th> </tr> </thead> <tbody> <tr> <td rowspan="2">Fuse-M</td> <td>0 Ω</td> <td>Go to the 3</td> </tr> <tr> <td>Other</td> <td>Change Fuse-M</td> </tr> <tr> <td rowspan="2">Def' Heater</td> <td>254.7 Ω ± 5%</td> <td>Go to the 3</td> </tr> <tr> <td>Other</td> <td>Change Fuse-M</td> </tr> <tr> <td rowspan="2">Def' Sensor</td> <td>0 Ω</td> <td>Go to the 3</td> </tr> <tr> <td>OFF</td> <td>Replace product</td> </tr> </tbody> </table>	Part	Result	SVC Action	Fuse-M	0 Ω	Go to the 3	Other	Change Fuse-M	Def' Heater	254.7 Ω ± 5%	Go to the 3	Other	Change Fuse-M	Def' Sensor	0 Ω	Go to the 3	OFF	Replace product
Part	Result		SVC Action																	
Fuse-M	0 Ω		Go to the 3																	
	Other		Change Fuse-M																	
Def' Heater	254.7 Ω ± 5%	Go to the 3																		
	Other	Change Fuse-M																		
Def' Sensor	0 Ω	Go to the 3																		
	OFF	Replace product																		
2	Check the <u>Defrost control part</u> . 																			
3	Input Test 2 Mode. (Push the button 2 times)																			
4	Check voltage in wires <u>Brown to Blue</u> in connector CON2 	<table border="1"> <thead> <tr> <th>Result</th> <th>SVC Action</th> </tr> </thead> <tbody> <tr> <td>220VAC ± 10VAC</td> <td>Go to the 5</td> </tr> <tr> <td>0 V</td> <td>Replace Main PCB</td> </tr> </tbody> </table>	Result	SVC Action	220VAC ± 10VAC	Go to the 5	0 V	Replace Main PCB												
Result	SVC Action																			
220VAC ± 10VAC	Go to the 5																			
0 V	Replace Main PCB																			
5	Release the test mode. Push the button 1 times. (normal)																			
6	Check voltage in wires <u>Brown to Blue</u> in connector CON2 	<table border="1"> <thead> <tr> <th>Result</th> <th>SVC Action</th> </tr> </thead> <tbody> <tr> <td>0 V</td> <td>Nomal</td> </tr> <tr> <td>220VAC ± 10VAC</td> <td>Replace Main PCB</td> </tr> </tbody> </table>	Result	SVC Action	0 V	Nomal	220VAC ± 10VAC	Replace Main PCB												
Result	SVC Action																			
0 V	Nomal																			
220VAC ± 10VAC	Replace Main PCB																			

6) Refrigerator Room LED Module doesn't work

No	Checking Flow	Result & SVC Action								
1	<p>Check the Refrigerator Door Switch Open refrigerator door. Check visually the magnetic switch on the door. Magnetic switch wires are loose?</p> 	<p>If the wires of magnetic switch are loose, replace the switch. If they're not, go to step 2.</p>								
2	<p>Disconnect the magnetic switch and confirm if continuity between the terminals exists. Is there continuity?</p>  <table border="1" data-bbox="274 1262 833 1434"> <thead> <tr> <th colspan="3">Resistance [Ω]</th> </tr> </thead> <tbody> <tr> <td rowspan="2">Door Magnetic Switch</td> <td>Normal</td> <td>Infinity</td> </tr> <tr> <td>Place the magnet near to the magnetic switch</td> <td>0</td> </tr> </tbody> </table>	Resistance [Ω]			Door Magnetic Switch	Normal	Infinity	Place the magnet near to the magnetic switch	0	<p>If there is continuity between the terminals of magnetic switch, replace the switch. If there is not continuity, go to step 3.</p>
Resistance [Ω]										
Door Magnetic Switch	Normal	Infinity								
	Place the magnet near to the magnetic switch	0								
3	<p>Disconnect the magnetic switch and confirm if continuity between the terminals exists or not. Is there continuity when you close magnetic switch with the magnet placed on the door?</p>  <p>NOTE: For detecting continuity, the magnet and switch magnetic must be aligned.</p>	<p>If there is not continuity in the magnetic switch (when is close to the door magnet), replace the switch. If there is continuity, go to step 4.</p>								

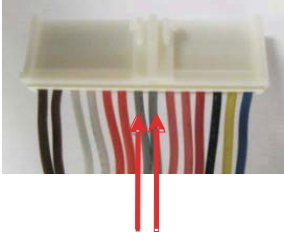
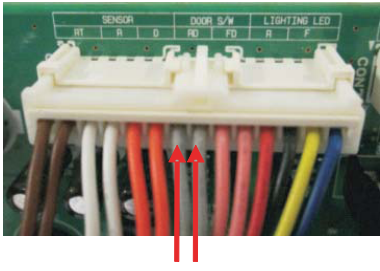
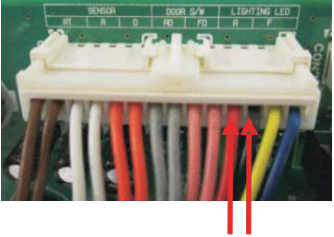
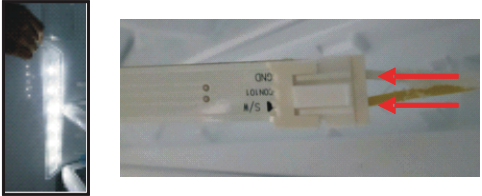

6) Refrigerator Room LED Module doesn't work

No	Checking Flow	Result & SVC Action													
4	<p>1.- Unplug connector from CON8. 2.- Check resistance in wires <u>Gray to Gray</u>.</p> 	<table border="1"> <thead> <tr> <th>Status</th> <th>Result</th> <th>SVC Action</th> </tr> </thead> <tbody> <tr> <td rowspan="2">Normal</td> <td>0 Ω</td> <td>Go to the 3</td> </tr> <tr> <td>Other</td> <td>Change door S/W</td> </tr> <tr> <td rowspan="2">Push S/W</td> <td>Infinity</td> <td>Go to the 3</td> </tr> <tr> <td>Other</td> <td>Change door S/W</td> </tr> </tbody> </table>	Status	Result	SVC Action	Normal	0 Ω	Go to the 3	Other	Change door S/W	Push S/W	Infinity	Go to the 3	Other	Change door S/W
Status	Result	SVC Action													
Normal	0 Ω	Go to the 3													
	Other	Change door S/W													
Push S/W	Infinity	Go to the 3													
	Other	Change door S/W													
5	<p>Plug in CON8, check voltage in wires <u>Gray to Gray</u>.</p> 	<table border="1"> <thead> <tr> <th>Status</th> <th>Result</th> <th>SVC Action</th> </tr> </thead> <tbody> <tr> <td rowspan="2">Closed</td> <td>5 V</td> <td>Normal</td> </tr> <tr> <td>Other</td> <td>Change the PCB</td> </tr> <tr> <td rowspan="2">Open</td> <td>0 V</td> <td>Go to the 4</td> </tr> <tr> <td>Other</td> <td>Change the PCB</td> </tr> </tbody> </table>	Status	Result	SVC Action	Closed	5 V	Normal	Other	Change the PCB	Open	0 V	Go to the 4	Other	Change the PCB
Status	Result	SVC Action													
Closed	5 V	Normal													
	Other	Change the PCB													
Open	0 V	Go to the 4													
	Other	Change the PCB													
6	<p>Check voltage in wires <u>Red to Black</u> from CON8</p> 	<table border="1"> <thead> <tr> <th>Status</th> <th>Result</th> <th>SVC Action</th> </tr> </thead> <tbody> <tr> <td rowspan="2">Closed</td> <td>12 V</td> <td>Normal</td> </tr> <tr> <td>Other</td> <td>Change the PCB</td> </tr> <tr> <td rowspan="2">Open</td> <td>0 V</td> <td>Normal</td> </tr> <tr> <td>Other</td> <td>Change the PCB</td> </tr> </tbody> </table>	Status	Result	SVC Action	Closed	12 V	Normal	Other	Change the PCB	Open	0 V	Normal	Other	Change the PCB
Status	Result	SVC Action													
Closed	12 V	Normal													
	Other	Change the PCB													
Open	0 V	Normal													
	Other	Change the PCB													
7	<p>Check voltage in Refrigerator LED Connector</p> 	<table border="1"> <thead> <tr> <th>Status</th> <th>Result</th> <th>SVC Action</th> </tr> </thead> <tbody> <tr> <td rowspan="2">Open</td> <td>12 V</td> <td>Change Freezer LED</td> </tr> <tr> <td>Other</td> <td>Change the PCB</td> </tr> <tr> <td rowspan="2">Closed</td> <td>0 V</td> <td>Normal</td> </tr> <tr> <td>Other</td> <td>Change the PCB</td> </tr> </tbody> </table>	Status	Result	SVC Action	Open	12 V	Change Freezer LED	Other	Change the PCB	Closed	0 V	Normal	Other	Change the PCB
Status	Result	SVC Action													
Open	12 V	Change Freezer LED													
	Other	Change the PCB													
Closed	0 V	Normal													
	Other	Change the PCB													

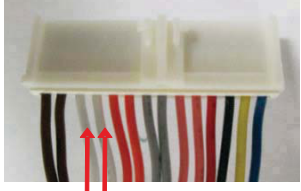
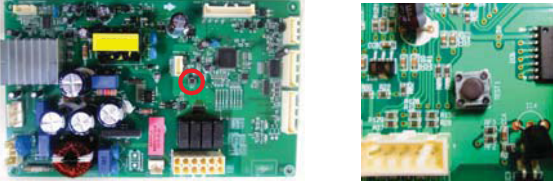
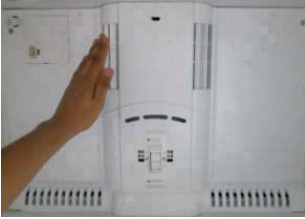
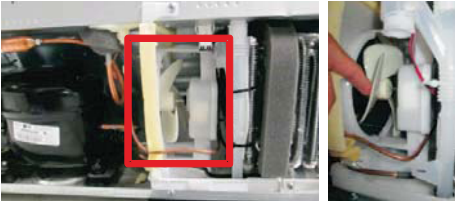
7) Poor cooling in Refrigerator room

No	Checking flow	Result & SVC Action												
1	<p>1.- Unplug connector from CON8. 2.- Check resistance in wires <u>White to White.</u></p>  <p>※ The sensor is determined by the temperature. For example, 30kΩ indicates 32°F.</p>	<table border="1"> <thead> <tr> <th>Temperature</th> <th>Result</th> </tr> </thead> <tbody> <tr> <td>23°F / -5°C</td> <td>38 kΩ</td> </tr> <tr> <td>32°F / 0°C</td> <td>30 kΩ</td> </tr> <tr> <td>41°F / 5°C</td> <td>24 kΩ</td> </tr> <tr> <td>50°F / 10°C</td> <td>19.5 kΩ</td> </tr> <tr> <td>59°F / 15°C</td> <td>16 kΩ</td> </tr> </tbody> </table>	Temperature	Result	23°F / -5°C	38 kΩ	32°F / 0°C	30 kΩ	41°F / 5°C	24 kΩ	50°F / 10°C	19.5 kΩ	59°F / 15°C	16 kΩ
Temperature	Result													
23°F / -5°C	38 kΩ													
32°F / 0°C	30 kΩ													
41°F / 5°C	24 kΩ													
50°F / 10°C	19.5 kΩ													
59°F / 15°C	16 kΩ													
2	<p>Reset the unit and Input Test 1 Mode. (push the button 1 time)</p>													
3	<p>Open the freezer door and Check the air flow.</p> 	<table border="1"> <thead> <tr> <th>Status</th> <th>SVC Action</th> </tr> </thead> <tbody> <tr> <td>Windy</td> <td>Go to the 4</td> </tr> <tr> <td>No windy</td> <td>Check the Fan motor (Next page)</td> </tr> </tbody> </table>	Status	SVC Action	Windy	Go to the 4	No windy	Check the Fan motor (Next page)						
Status	SVC Action													
Windy	Go to the 4													
No windy	Check the Fan motor (Next page)													
4	<p>Check the air temperature. Cold or not ?</p>	<table border="1"> <thead> <tr> <th>Status</th> <th>SVC Action</th> </tr> </thead> <tbody> <tr> <td>Cold</td> <td>Normal</td> </tr> <tr> <td>Not cold</td> <td>Check the Compressor And sealed system</td> </tr> </tbody> </table>	Status	SVC Action	Cold	Normal	Not cold	Check the Compressor And sealed system						
Status	SVC Action													
Cold	Normal													
Not cold	Check the Compressor And sealed system													
5	<p>Check the Fan motor. Rotate fan using your hand. It feel sticky, change the motor. (cause of ice or rust inside of motor)</p> 	<table border="1"> <thead> <tr> <th>Point</th> <th>Result</th> <th>SVC Action</th> </tr> </thead> <tbody> <tr> <td>Motor</td> <td>Release</td> <td>Check section Cooling BLDC Fan Motor Error</td> </tr> </tbody> </table>	Point	Result	SVC Action	Motor	Release	Check section Cooling BLDC Fan Motor Error						
Point	Result	SVC Action												
Motor	Release	Check section Cooling BLDC Fan Motor Error												

8) Over cooling in Refrigerator room

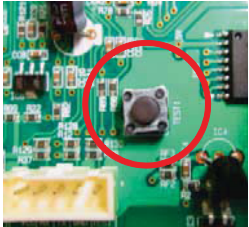
No	Checking flow	Result & SVC Action												
1	<p>1.- Unplug connector from CON8. 2.- Check resistance in wires <u>White to White.</u></p>  <p>※ The sensor is determined by the temperature. For example, 30kΩ indicates 32°F.</p>	<table border="1"> <thead> <tr> <th data-bbox="927 415 1141 464">Temperature</th> <th data-bbox="1141 415 1354 464">Result</th> </tr> </thead> <tbody> <tr> <td data-bbox="927 464 1141 512">23°F / -5°C</td> <td data-bbox="1141 464 1354 512">38 kΩ</td> </tr> <tr> <td data-bbox="927 512 1141 560">32°F / 0°C</td> <td data-bbox="1141 512 1354 560">30 kΩ</td> </tr> <tr> <td data-bbox="927 560 1141 609">41°F / 5°C</td> <td data-bbox="1141 560 1354 609">24 kΩ</td> </tr> <tr> <td data-bbox="927 609 1141 657">50°F / 10°C</td> <td data-bbox="1141 609 1354 657">19.5 kΩ</td> </tr> <tr> <td data-bbox="927 657 1141 705">59°F / 15°C</td> <td data-bbox="1141 657 1354 705">16 kΩ</td> </tr> </tbody> </table>	Temperature	Result	23°F / -5°C	38 kΩ	32°F / 0°C	30 kΩ	41°F / 5°C	24 kΩ	50°F / 10°C	19.5 kΩ	59°F / 15°C	16 kΩ
Temperature	Result													
23°F / -5°C	38 kΩ													
32°F / 0°C	30 kΩ													
41°F / 5°C	24 kΩ													
50°F / 10°C	19.5 kΩ													
59°F / 15°C	16 kΩ													
2	<p>Reset the unit and Input Test 1 Mode. (push the button 1 time)</p>													
3	<p>Open the refrigerator door and Check the air flow.</p> 	<table border="1"> <thead> <tr> <th data-bbox="927 1052 1086 1100">Status</th> <th data-bbox="1086 1052 1404 1100">SVC Action</th> </tr> </thead> <tbody> <tr> <td data-bbox="927 1100 1086 1148">Windy</td> <td data-bbox="1086 1100 1404 1148">Go to the 4</td> </tr> <tr> <td data-bbox="927 1148 1086 1197">No windy</td> <td data-bbox="1086 1148 1404 1197">Check the PCB</td> </tr> </tbody> </table>	Status	SVC Action	Windy	Go to the 4	No windy	Check the PCB						
Status	SVC Action													
Windy	Go to the 4													
No windy	Check the PCB													
4	<p>Input Test 2 Mode and Check the air flow. (push the button 1 time)</p> 	<table border="1"> <thead> <tr> <th data-bbox="927 1381 1086 1430">Status</th> <th data-bbox="1086 1381 1404 1430">SVC Action</th> </tr> </thead> <tbody> <tr> <td data-bbox="927 1430 1086 1478">Windy</td> <td data-bbox="1086 1430 1404 1478">Change the PCB</td> </tr> <tr> <td data-bbox="927 1478 1086 1526">No windy</td> <td data-bbox="1086 1478 1404 1526">It 's normal</td> </tr> </tbody> </table>	Status	SVC Action	Windy	Change the PCB	No windy	It 's normal						
Status	SVC Action													
Windy	Change the PCB													
No windy	It 's normal													



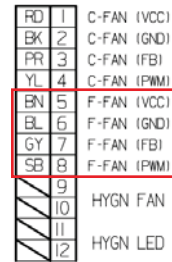
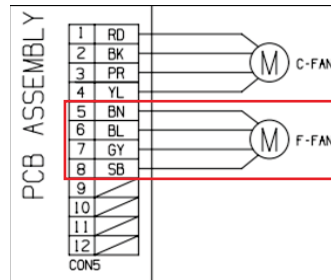
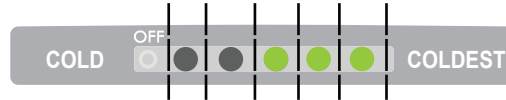

9) Freezer BLDC FAN Motor Error

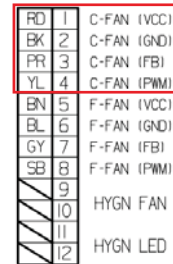
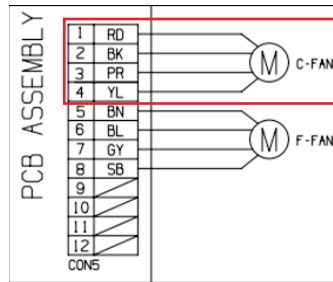
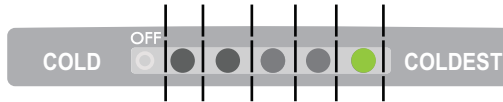

No	Checking flow	Result & SVC Action						
1	<p>Push the TEST Mode Check the loose connection</p> <p>Input Test 1 Mode. (push the button 1 times)</p>							
2	<p>Open the freezer door and Check the Air flow. (While an error code is displayed, the fan is not working)</p>	<table border="1"> <thead> <tr> <th>Status</th> <th>SVC Action</th> </tr> </thead> <tbody> <tr> <td>airflow</td> <td>Go to the 4</td> </tr> <tr> <td>No airflow</td> <td>Go to the 3</td> </tr> </tbody> </table>	Status	SVC Action	airflow	Go to the 4	No airflow	Go to the 3
Status	SVC Action							
airflow	Go to the 4							
No airflow	Go to the 3							
3	<p>Check the Fan motor.</p>	<p>Rotate fan using your hand It feel stuck or locked up, change the motor.</p>						
4	<p>Check the FAN Motor Voltage in wires <u>Brown to Blue.</u></p> <p><CON5></p>	<table border="1"> <thead> <tr> <th>Status</th> <th>SVC Action</th> </tr> </thead> <tbody> <tr> <td>8~15 Vdc</td> <td>Normal</td> </tr> <tr> <td>Below 1V or 16V</td> <td>Change the PCB</td> </tr> </tbody> </table>	Status	SVC Action	8~15 Vdc	Normal	Below 1V or 16V	Change the PCB
Status	SVC Action							
8~15 Vdc	Normal							
Below 1V or 16V	Change the PCB							
5	<p>Check the FAN Motor Feedback Voltage in wires <u>Blue to Gray.</u></p> <p><CON5></p>	<table border="1"> <thead> <tr> <th>Status</th> <th>SVC Action</th> </tr> </thead> <tbody> <tr> <td>1~4 Vdc</td> <td>Normal</td> </tr> <tr> <td>Other</td> <td>Change the PCB</td> </tr> </tbody> </table>	Status	SVC Action	1~4 Vdc	Normal	Other	Change the PCB
Status	SVC Action							
1~4 Vdc	Normal							
Other	Change the PCB							

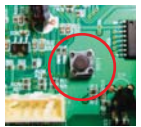
10) Cooling BLDC FAN Motor Error

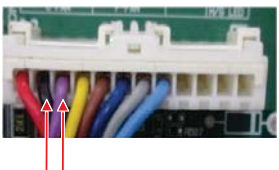

No	Checking flow	Result & SVC Action						
1	<p>Push the TEST Mode Check the loose connection</p> <p>Input Test 1 Mode. (push the button 1 times)</p>	 						
2	<p>Check the Fan motor rotate in machine room. (While an error code is displayed, the fan is not working)</p> 	<table border="1"> <thead> <tr> <th>Status</th> <th>SVC Action</th> </tr> </thead> <tbody> <tr> <td>airflow</td> <td>Go to the 4</td> </tr> <tr> <td>No airflow</td> <td>Go to the 3</td> </tr> </tbody> </table>	Status	SVC Action	airflow	Go to the 4	No airflow	Go to the 3
Status	SVC Action							
airflow	Go to the 4							
No airflow	Go to the 3							
3	<p>Check the Fan motor.</p> 	<p>Rotate fan using your hand. It feel stuck or locked up, change the motor.</p>						
4	<p>Check the FAN Motor Voltage in wires Red to Black.</p> 	<table border="1"> <thead> <tr> <th>Status</th> <th>SVC Action</th> </tr> </thead> <tbody> <tr> <td>8~15 Vdc</td> <td>Normal</td> </tr> <tr> <td>Below 1V or 16V</td> <td>Change the PCB</td> </tr> </tbody> </table>	Status	SVC Action	8~15 Vdc	Normal	Below 1V or 16V	Change the PCB
Status	SVC Action							
8~15 Vdc	Normal							
Below 1V or 16V	Change the PCB							
5	<p>Check the FAN Motor Feedback Voltage in wires Black to Purple.</p> 	<table border="1"> <thead> <tr> <th>Status</th> <th>SVC Action</th> </tr> </thead> <tbody> <tr> <td>1~4 Vdc</td> <td>Normal</td> </tr> <tr> <td>Other</td> <td>Change the PCB</td> </tr> </tbody> </table>	Status	SVC Action	1~4 Vdc	Normal	Other	Change the PCB
Status	SVC Action							
1~4 Vdc	Normal							
Other	Change the PCB							

3. Reference

1) Temperature compensation

1. How to make TEMP COMPENSATION

If you want to raise or drop basic temperature, cut the jump wire on the Main PCB.

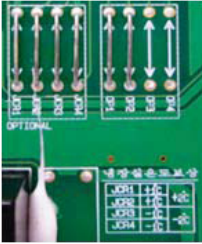
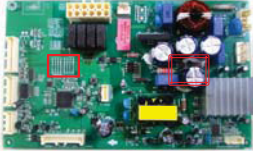

Refrigerator Room			
CUT OPTION		Temperature compensation	
	JCR1	+1.0 °C	Over cooling compensation
	JCR2	+1.0 °C	
	JCR3	-1.0 °C	Poor cooling compensation
	JCR4	-1.0 °C	

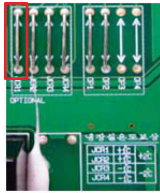

* JCR1 cuts : +1°C

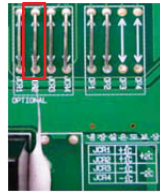

* JCR2 cuts : +1°C

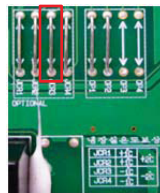

* JCR3 cuts : -1 °C

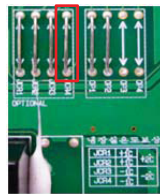

* JCR4 cuts : -1 °C

2) TEST MODE and Removing TPA

1. How to make TEST MODE

If you push the test button on the Main PCB, the refrigerator will be enter the TEST MODE

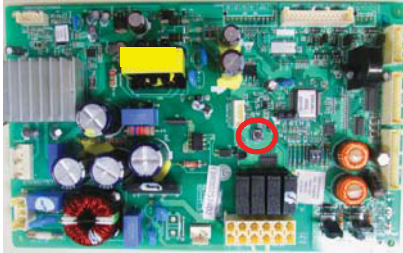

Main PCB

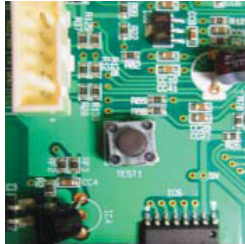

* 1 time : Comp ON /F-fan ON /
Defrost Heater OFF/
Display ALL ON

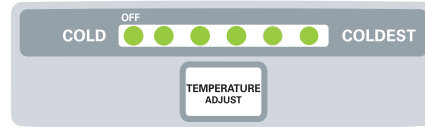

All LED turn on

* 2 times : Comp OFF/F-fan OFF/
Defrost Heater ON
("2" displayed)

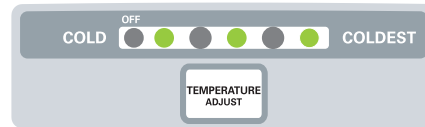

TEST MODE 2

2. How to remove Terminal Position Assurance (TPA)

<AC TPA>



<DC TPA>



* After measure the values, you should put in the TPA again

10. EXPLODED VIEW

CASE PARTS

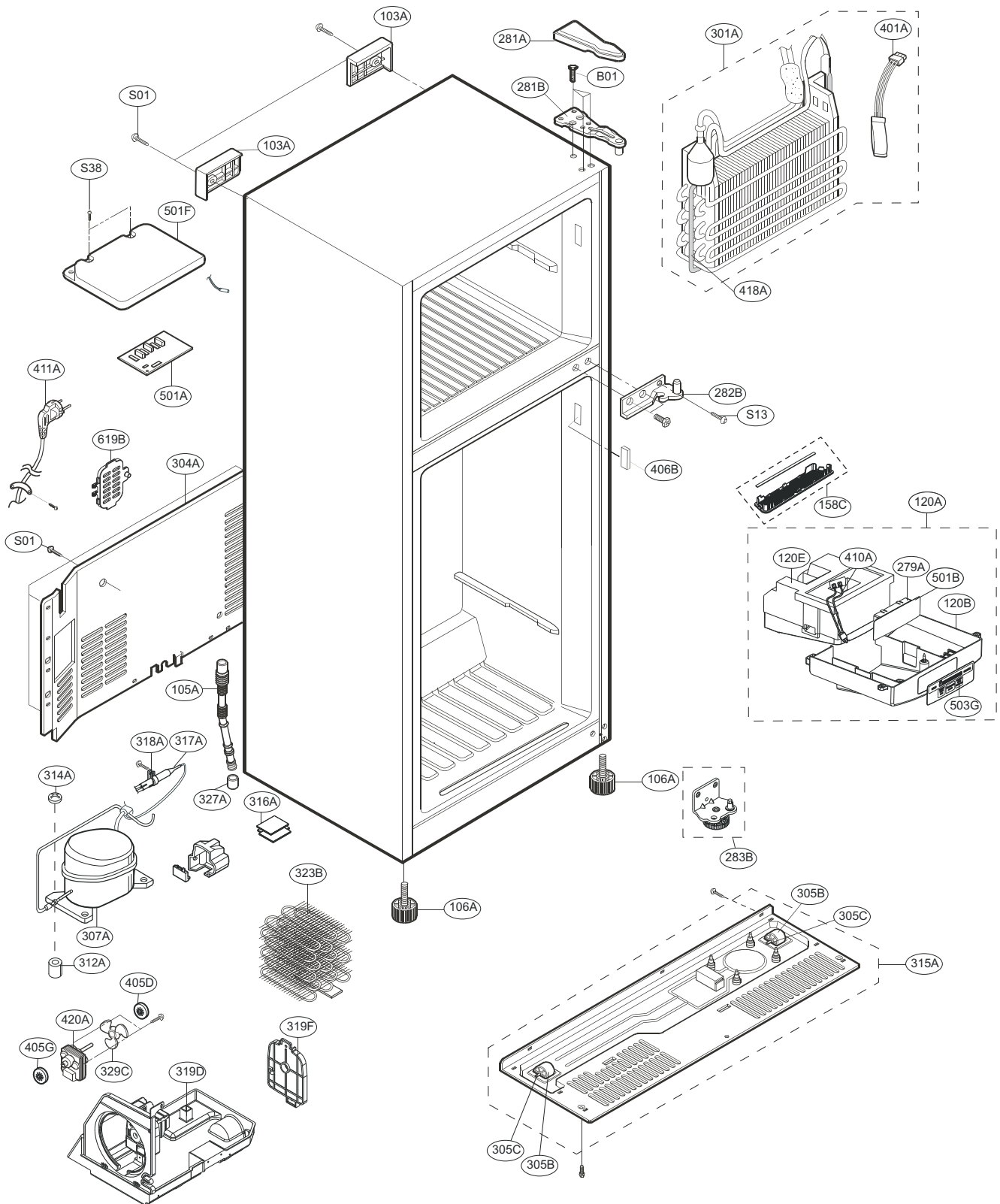

FREEZER PARTS

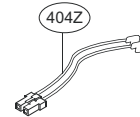
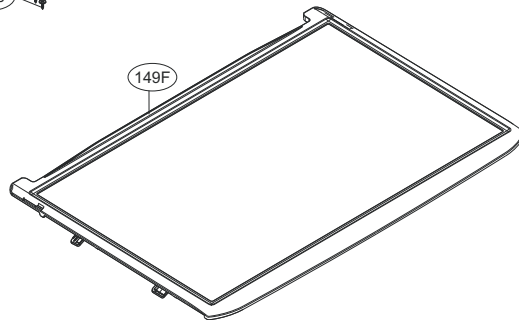
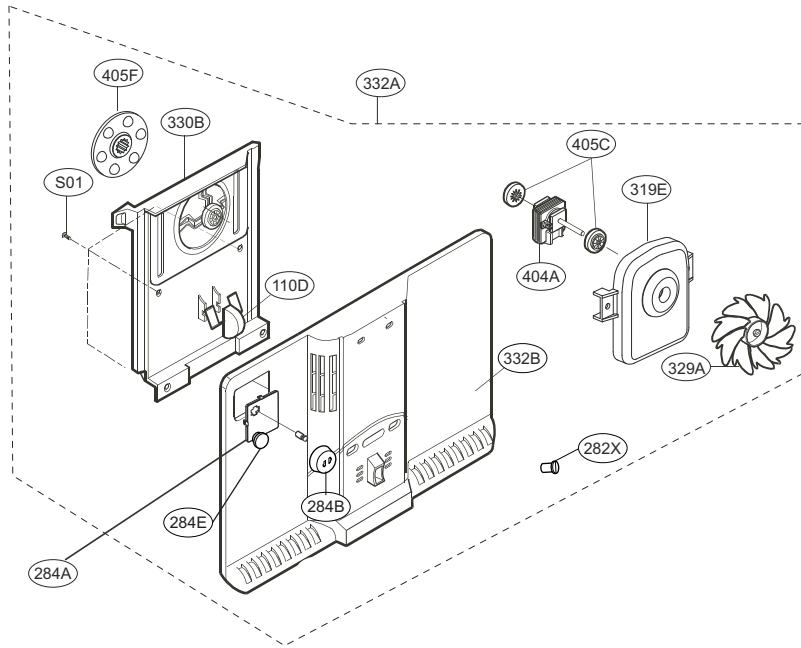

REFRIGERATOR PARTS

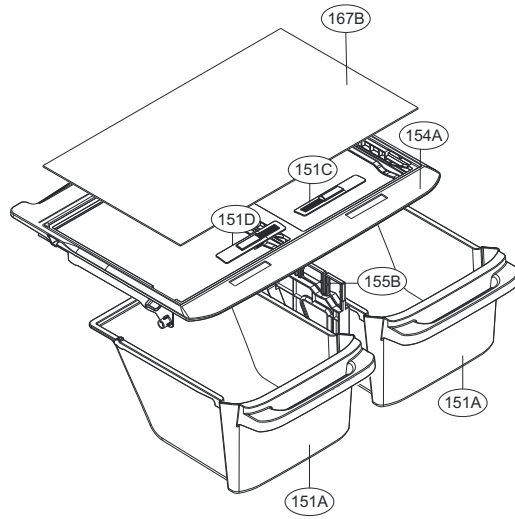
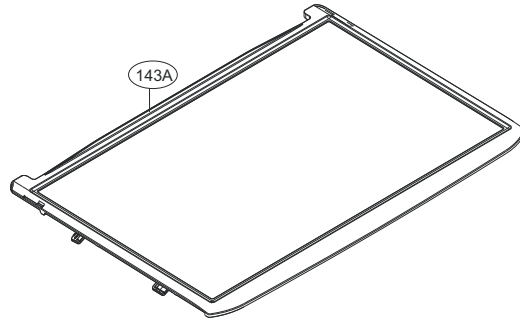

DOOR PARTS

