

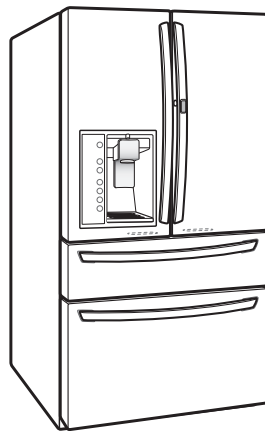

REFRIGERATOR

SERVICE MANUAL

CAUTION
BEFORE SERVICING THE UNIT,
READ THE SAFETY PRECAUTIONS IN THIS MANUAL.



MODEL : LMXC23746S

COLOR : STAINLESS(ST)

CONTENTS

SAFETY PRECATUTIONSS	2
1. SPECIFICATIONS	3
2. PARTS IDENTIFICATION	4
3. DISASSEMBLY	5-25
REMOVING AND REPALCING REFRIGERATOR DOORS	5
DOOR	6-7
SUB, PCB	8
DOOR ALIGNMENT	9
FAN AND FAN MOTOR.....	9-10
REFRIGERATOR LIGHT (TOP).....	11-12
MULTI DUCT	12
DISPENSER	13
DISPLAY PCB	13
CUSTOMCHILL DISPLAY	13-14
ICE BUTTON ASSEMBLY	14
WATER BUTTON ASSEMBLY	14
ICE CORNER DOOR REPLACEMENT.....	14
ICEMAKER REPLACEMENT	15
SUB PCB FOR WORKING DISPENSER	15
CAP DUCT MOTOR REPLACEMENT	16
MODULE FILTER REPLACAEMENT	16
MODULE FILTER PART REPLACEMENT.....	17
HOW TO REMOVE A ICE BIN	17
HOW TO INSERT A ICE BIN.....	17
CUSTOMCHILL DRAWER	18-21
HOT TO REMOVE AND REINSTALL THE PULLOUT DRAWER.....	22-23
WATER VALVE DISASSEMBLY METHOD	24
FAN MOTOR DISASSEMBLY METHOD	24
CAUTION : SEALED SYSTEM REPAIR	25
WAY VALVE SERVICE	25
4. ADJUSTMENT	26
COMPRESSOR.....	26
5. CIRCUIT DIAGRAM	27
6. TROUBLESHOOTING	28-29
7. PCB PICTURE	30-31
8. TROUBLESHOOTING WITH ERROR DISPLAY	32-74
9. REFERENCE	75-78
10. COMPONENT TESTING INFORMATION	79-88
11. COMPRESSOR TROUBLESHOOTING	89-101
12. ICEMAKER OPERATING METHOD AND TROUBLE SHOOTING	102-105
13. DESCRIPTION OF FUNCTION & CIRCUIT OF MICOM	106-109
14. EXPLODED VIEW & REPLACEMENT PARTS LIST	110

SAFETY PRECAUTIONS

Please read the following instructions before servicing your refrigerator.

1. Unplug the power before handling any elctrical componets.
2. Check the rated current, voltage, and capacity.
3. Take caution not to get water near any electrical components.
4. Use exact replacement parts.
5. Remove any objects from the top prior to tilting the product.

1. SPECIFICATIONS

1-1 LMXC23746S

● 22.7 cu.ft.

ITEMS	SPECIFICATIONS
DOOR DESIGN	Side Rounded
DIMENSIONS (inches)	35 3/4 X 31 1/5 X 70 1/4 (W X D X H)22.7cu.ft
NET WEIGHT (pounds)	150kg(330lb)
COOLING SYSTEM	Fan Cooling
TEMPERATURE CONTROL	Micom Control
DEFROSTING SYSTEM	Full Automatic Heater Defrost
DOOR FINISH	Stainless
HANDLE TYPE	Bar
INNER CASE	ABS Resin
INSULATION	Polyurethane Foam

ITEMS	SPECIFICATIONS	
VEGETABLE TRAY	Clear Drawer Type	
COMPRESSOR	Linear	
EVAPORATOR	Fin Tube Type	
CONDENSER	Spiral Condenser (Al)	
REFRIGERANT	R-134a(135g)	
LUBRICATING OIL	ISO10 (280 ml)	
DEFROSTING DEVICE	SHEATH HEATER	
LAMP	REFRIGERATOR	LED Module
	FREEZER	LED Module

● DIMENSIONS

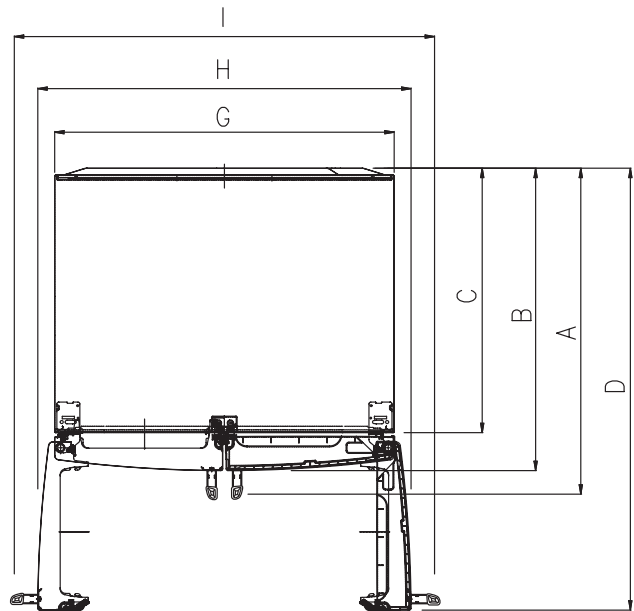
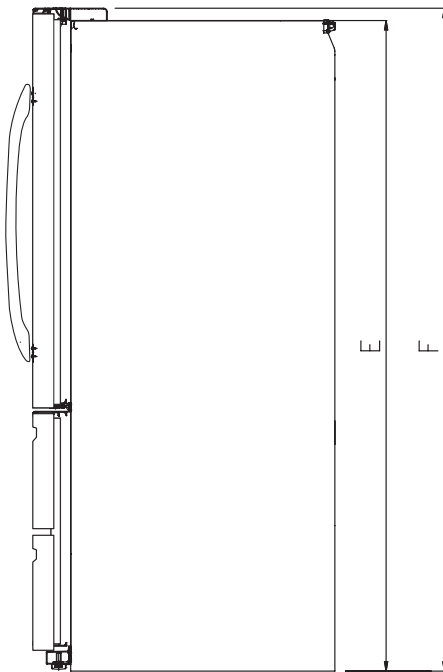

Description		LMXC23746S
Depth w/ Handles	A	31 3/4 in
Depth w/o Handles	B	28 3/4 in
Depth w/o Door	C	24 in
Depth (Total with Door Open)	D	42 5/8 in
Height to Top of Case	E	68 3/4 in
Height to Top of Door Hinge	F	70 1/4 in
Width	G	35 3/4 in
Width (door open 90 deg. w/o handle)	H	40 in
Width (door open 90 deg. w/ handle)	I	45 in

2. PARTS IDENTIFICATION

LED interior lamps
The interior lamps light up the inside of the refrigerator.

Indoor Ice Bin
Ice cubes are automatically produced.

Crisper
Controls humidity and helps vegetables and fruit to stay crisp.

CustomChill™ Drawer
Variable temperature storage that can be set either colder or warmer than the refrigerator.

Dairy Product Bin
Used to preserve dairy products.

Adjustable Refrigerator Shelf
The shelves in your refrigerator are adjustable to meet your individual storage needs.

Modular Door Bin
Interchangeable bins can be arranged to suit your storage needs.

EasyReach™
You can store small items, or defrost an item.

Pullout Drawer
Used for extra storage within the freezer compartment.

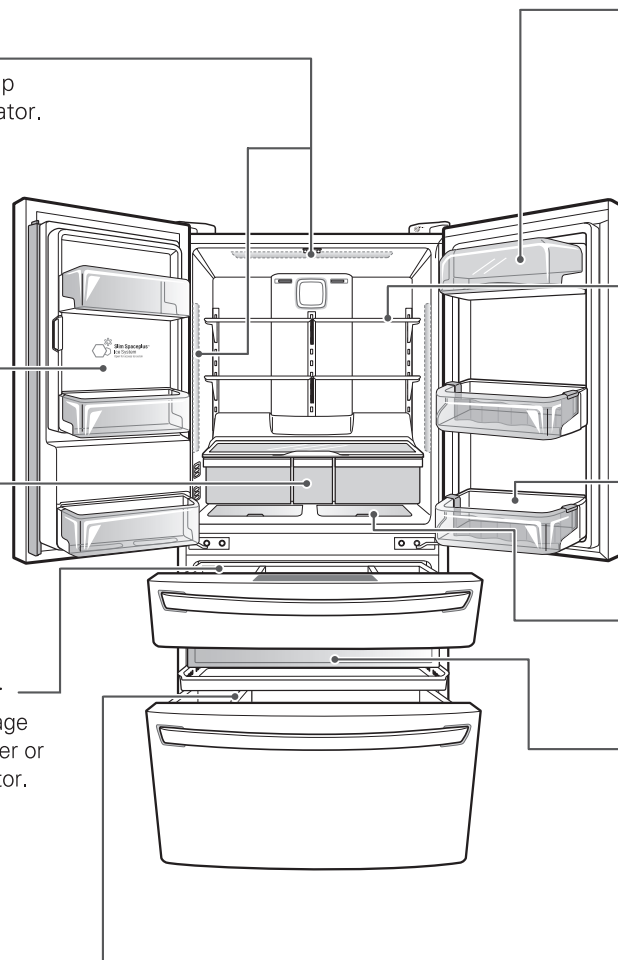

Durabase® and Durabase® Divider
The Durabase is a storage space recommended for the preservation of large food items. The Durabase Divider is used to organize the Durabase area into sections. It can be adjusted from side to side to accommodate items of different sizes.

3. DISASSEMBLY

3- 1 REMOVING AND REPLACING REFRIGERATOR DOORS

● Removing Refrigerator Door

▲ CAUTION: Before you begin, unplug the refrigerator. Remove food and bins from doors.

▶ Left Door - FIG. 2

1. Disconnect water supply tube by pushing back on the disconnect ring (3).-FIG. 1
2. Open door. Loosen top hinge cover screw (1).
- Use flat tip screwdriver to pry back hooks on front underside of cover (2). Lift up cover.
3. Disconnect door switch wire harness and remove the cover.
4. Pull out the tube.
5. Disconnect all 3 wiring harnesses (4). Remove the grounding screw (5).
6. Rotate hinge lever (6) counterclockwise. Lift top hinge (7) free of hinge lever latch (8).

▲ CAUTION: When lifting hinge free from the latch, be careful that door does not fall forward.

7. Lift door from middle hinge pin and remove door.
8. Place the door with the insides facing up, on a not scratch surface.

▶ Right Door - FIG. 3

1. Open the door, remove 1 screw on the top of the hinge cover. Loosen top hinge cover screw (1). Lift up cover (2).
2. Disconnect door switch wire harness and remove the cover.
3. Rotate hinge lever (3) clockwise. Lift top hinge (4) free of hinge lever latch (5).
4. Lift door from middle hinge pin and remove door.

▲ CAUTION: When lifting hinge free from the latch, be careful that the door does not fall forward.

5. Place the door with the insides facing up, on a not scratch surface.

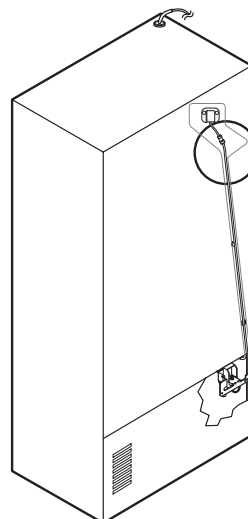
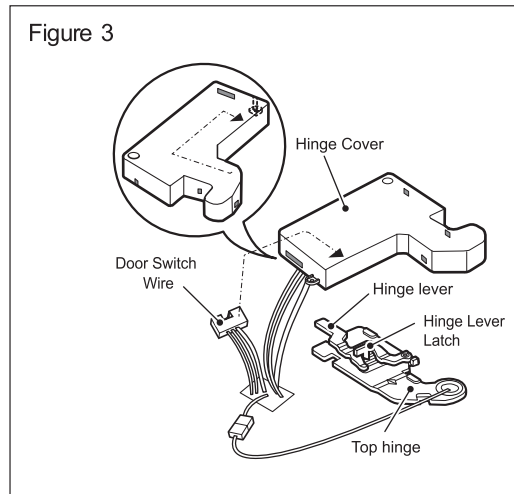
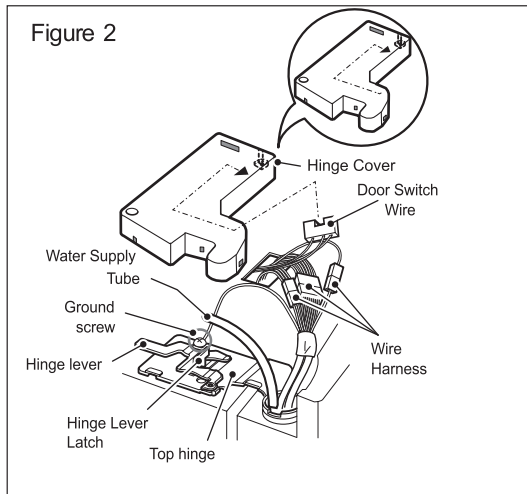
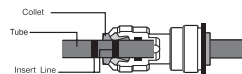
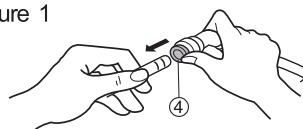
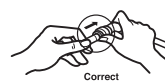

Figure 1



- 1) Insert the tube until you can see only one of the lines printed on the tube.
- 2) After inserting, pull the tube to ascertain that it is secure.



3-2 DOOR

● Mullion Removal

1. Remove 2 screws.



2. Lift mullion up carefully.



3. Disconnect wire harness.



● Door Gasket Removal

1. Remove gasket
Remove the gasket from gasket channel at doorliner as shown in the illustration below.

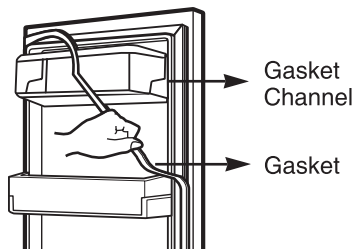

● Door Gasket Replacement

1. Insert gasket into channel
Insert and press gasket into channels at doorliner.

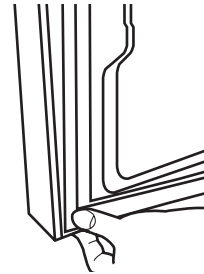

● Mullion Removal

1. Remove 2 Screws.



2. Lift mullion up carefully.



3. Disconnect wier harness.



● Mullion Replacement

1. Connect wier harness.



2. Insert mullion into channel.
Insert the mullion into channel at door as shown below.



3. Assemble 2 screws.

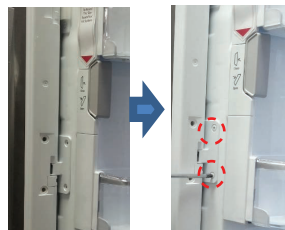

3-3 Sub,PCB

● Sub,PCB Removal

1. Remove 1 Screw.

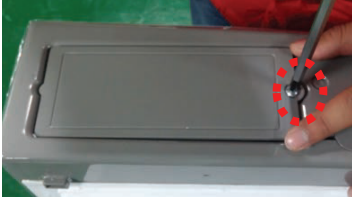

2. Lift Sub PCB up carefully.

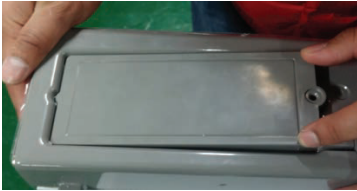

3. Reverse the Suc PCB cover.

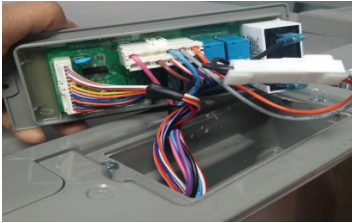

4. Disconnect capacitor housing.



5. Disconnect capacitor Joint wire harness.



6. Disconnect wire harness.



● Sub,PCB Replacement

1. Reverse the Suc PCB cover.



2. Connect capacitor Joint wire harness.

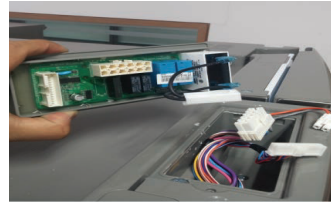

3. Connect wire harness.

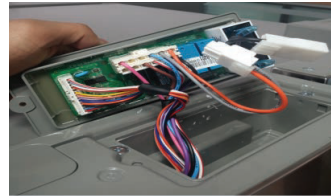

4. Connect the capacitor housing.



5. Insert the Sub PCB sideling.



6. Assemble 1 screw.



3-4 Door Alignment

If the level of refrigerator doors is uneven, follow the instructions below to align the doors:

Turn the leveling legs (CCW) to raise or (CW) to lower the height of the front of the refrigerator by using flat blade screw driver or 11/32" wrench. Use the wrench (Included with the User Manual) to adjust the bolt in the door hinge to adjust the height. (CW to raise or CCW to lower the height.) The Left refrigerator door has an adjustable nut, located on the bottom hinge, to raise and lower them to align properly. If the space between your doors is uneven, follow the instructions below to align the Left door evenly: Use the wrench (included with the Use & Care Guide) to turn the nut in the door hinge to adjust the height To the right to raise or to the left to lower the height.

On the other hand, The Right refrigerator door does not have an adjustable nut. If the space between your doors is uneven, follow the instructions below to align the Right door:

1. With one hand, lift up the Right door you want to raise at middle hinge.
2. With other hand, use pliers to insert snap ring as shown.
3. Insert additional snap rings until the Right door is aligned. (Three snap rings are provided with unit.)

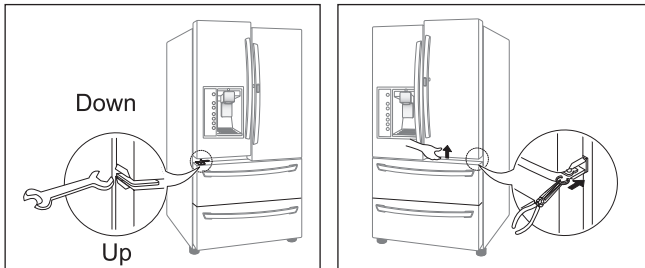

3-5 FAN AND FAN MOTOR

1. Remove the freezer drawer.
2. Remove the plastic guide for slides on left side by unscrewing phillips head screws.
3. Remove the grille assembly by removing four screws and pulling the grille assembly forward.
4. Remove the Fan Motor assembly by loosening 3 screws and disassembling the shroud.
5. Pull out the fan and separate the Fan Motor and Bracket Motor.

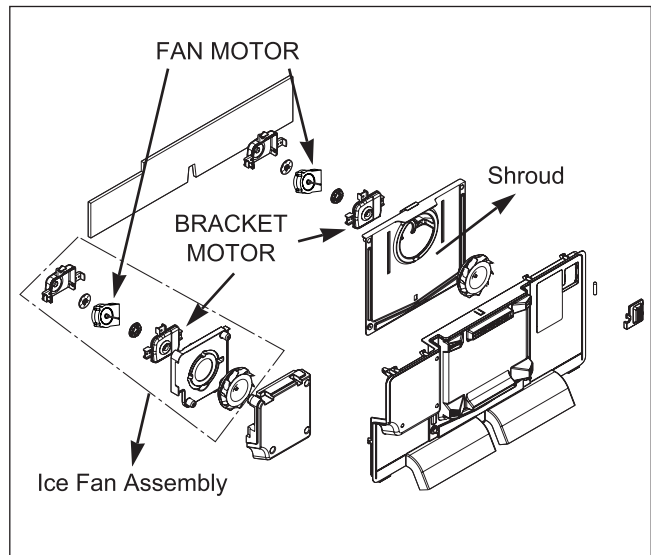

* Ice Fan Assembly Replacement

- 1) Remove the plastic guide for slides on left side by unscrewing phillips head screws.
- 2) Put your hand into the inside of grille to disassemble using the hook(3 point) shown in the figure.
- 3) Disconnect wire harness of the grille assembly.
- 4) Remove the Ice fan assembly by loosening all screws.



(1)



(2)



(3)



(4)

3-6 Refrigerator Light (Top)

Unplug Refrigerator, or disconnect power at the circuit breaker.

If necessary, remove top shelf or shelves.

3-6-1 Refrigerator Compartment Lamp

- 1) Unplug refrigerator power cord from electric outlet.
- 2) Put flat screwdriver into service hole and remove cover of refrigerator light.



- 3) Remove the LED assembly from connector.



- 4) Replace the LED assembly.

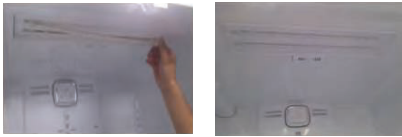

3-6-2 Refrigerator Light (Side)

1. Unplug refrigerator power cord from electric outlet.
2. Put flat screwdriver into service hole and remove cover of refrigerator light.



3. Remove the LED assembly from connector.



4. Replace LED assembly.



5. Assemble the cover in reverse order.

3-6-3 Cap Duct LED LAMP(Bottom)

1. Unplug refrigerator power cord from electric outlet.
2. Open the refrigerator door to need diassembly.
3. Put flat screwdriver into service hole, remove the cover of cap duct LED LAMP.



4. Remove the LED assembly from connector.

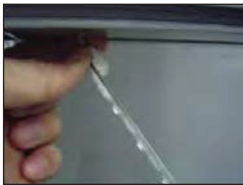

5. Replace LED assembly.



6. Assembly the cover in reverse order.

3-7 MULTI DUCT

1. Remove 1 screws as shown figure and remove the cover.



2. Disassemble Housing.



3. Remove the upper and lower Caps by using a flat screwdriver and remove 2 screws as shown figure.



4. Disconnect the lead wire on the bottom position

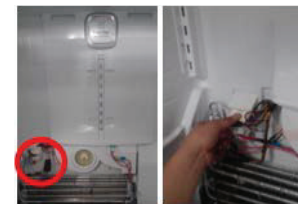

5. Grip both side of multi duct, pull it out.



3-8 DISPENSER



1) Pull out the drain



2) Holding the inner side of the dispenser pull forward to remove.



3) If nozzle is interfered with button, push and pull out the bottom of button.



4) Remove the lead wire.

▲ CAUTION: When replacing the dispenser cover make sure the lead wire does NOT come off and the water line is not pinched by the dispenser.



3-9 DISPLAY PCB

As shown below, remove 1 screw on the PCB fixing screw. Remove the display PCB fixing screw.



Case, PCB

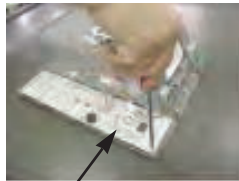

Display PCB

3-10. CustomChill DISPLAY



Working Tool

1. Screw (Length '12mm~', Sharply pointed)



3. Pliers

2. Driver



1. Put a screw in the center of display.



2. Drive a screw by using driver.



3. Put the screw up by using a pliers.



4. Disassemble Housing.

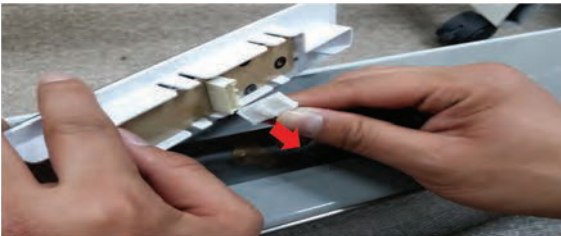

5. Assemble housing to New display

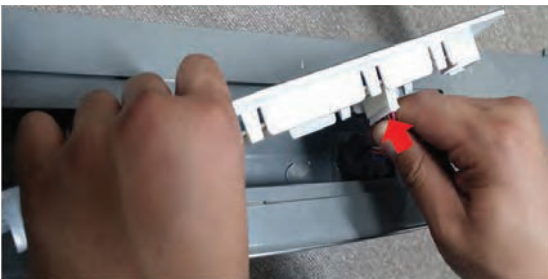

6. Put display down and Press Display until assemble thoroughly



3-11 ICE BUTTON ASSEMBLY

- 1) Remove the 1 screw holding the lever.
- 2) Remove the spring from the hook.
- 3) Push and pull on the tab to remove.



Button Lever

3-12 WATER BUTTON ASSMEBLY

- 1) Remove screws.
- 2) Grasp the Button assembly and lift.

Button Lever



3-13 ICE CORNER DOOR REPLACEMENT

- 1) Loosen the front screw as shown in the picture.
- 2) Lift up the hinge with one hand.
- 3) Pull out the Ice Corner Door with the other hand.



3-14 ICEMAKER REPLACEMENT

1) Remove 3 screws as shown.

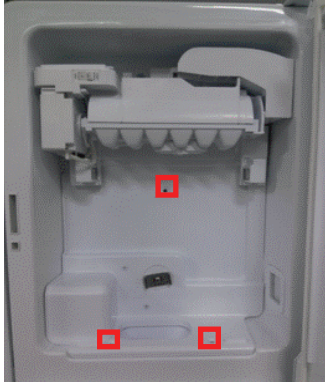

2) Grasp the bottom of motor cover assembly and pull slowly.



3) Disconnect wire harness from wall of compartment.



▲ CAUTION: Make sure that the motor housing is taped to the mold, if not positioned correctly the cover will not fit properly.

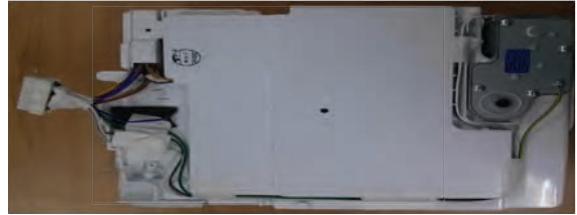

3-15 SUB PCB FOR WORKING DISPENSER

1) Disconnect the wire harness.



2) Remove 1 screw from PCB and replace with new PCB.



3-16 CAP DUCT MOTOR REPLACEMENT

1) Separate the Housing of the Cap Duct Motor.



2) Unscrew 3 screws to disassemble the motor.



3) When replacing the motor, check the position of the door duct and the link for proper fit.

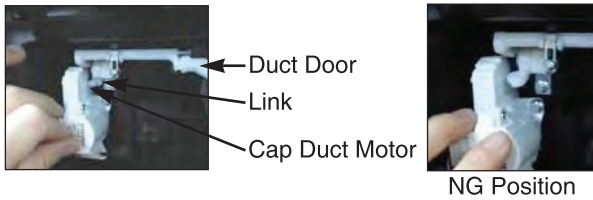

4) Insert 2 screws.



5) Push housing aside.

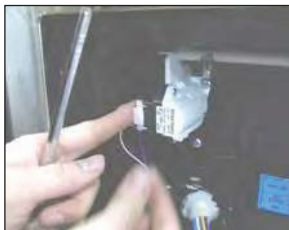

3-17 Module filter Replacement

1) Open the basket



2) loosen a screw



3) Disconnect the Valve housing



4) Disconnect the Blue Tube First, and then Disconnect the Orange tube. Lastly Disconnect the White Tube



①

②

③

[Installation order : Connect Orange → Blue → white]

5) Replace the new Module Filter



3-18 Module filter Part Replacement

- 1) Loosen the 3 screw

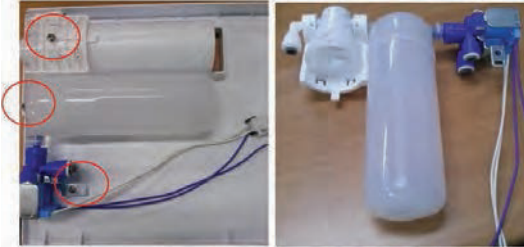

- 2) Hold the Connector and then Turn 90° to disconnect from Filter head Turn 90° The Water Tank to disconnect from Filter head

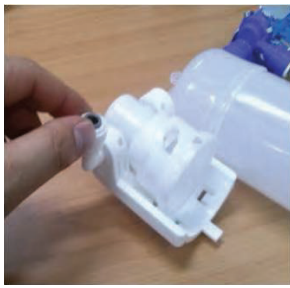

- 3) Remove the Snap Ring



- 4) Module Filter part are separated



3-19 HOW TO REMOVE A ICE BIN

- 1) Grip the handles, as shown.

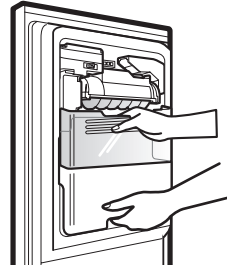

- 2) Tilt and lift slightly as shown.

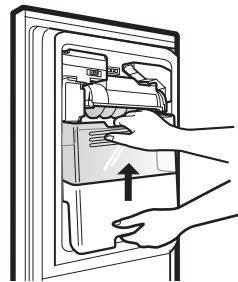

- 3) Remove ice bin slowly.

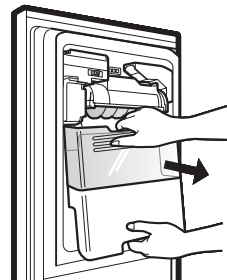

3-20 HOW TO INSERT A ICE BIN

- 1) Insert the Ice Bin, slightly tilting to avoid touching the Icemaker. (Especially, Ice-Detecting Sensor)

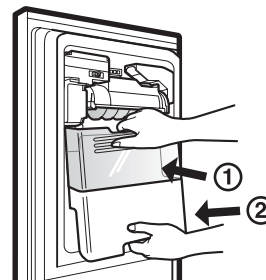

3-20 CustomChill Drawer

3-20-1 Follow steps to Remove

- 1 Pull the drawer open to full extension. Remove the basket by lifting the basket from the rail system.

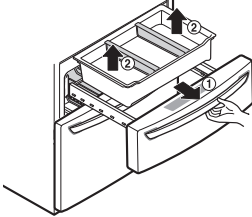

Disconnect the wire harness connection at the end of the right rail.

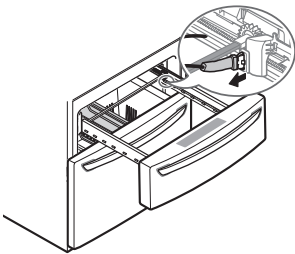

Remove the screws on both the left and right rails.

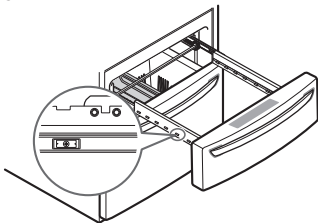

Grasp the drawer on each side and pull it up to separate it from the rails.

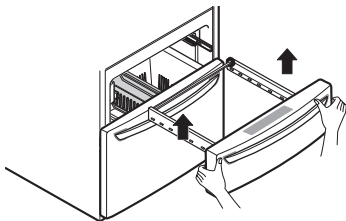

With both hands, hold each rail and push it in to allow both rails to slide in simultaneously.

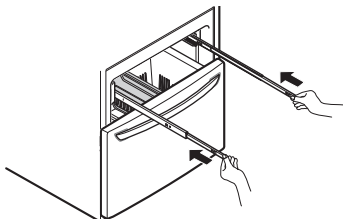

3-20-2 Follow steps to Reinstall

- 2 With both hands, pull out each rail simultaneously until both rails are fully extended.

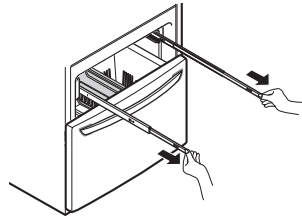

Grasp the drawer on each side and hook the door supports (1) into the rail tabs (2) located on both sides.

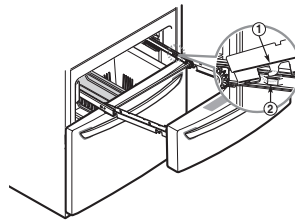

Reconnect the wire harness to the connection at the end of the right rail.

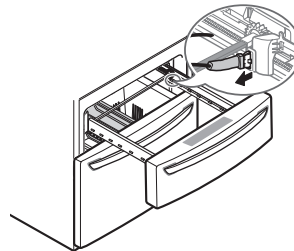

Lower the door into final position and tighten the screws located on both sides.

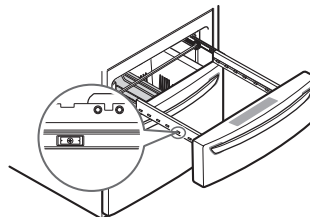

3-20-3. HOW TO REMOVE THE CUSTOMCHILL

1. Pull the drawer open to full extension.



4. Pull out door.



2. Separate housing.



5. Loosen a screw.



3. Loosen a screw



6. Loosen a screw.



7. Unhook cover from the rear to the head

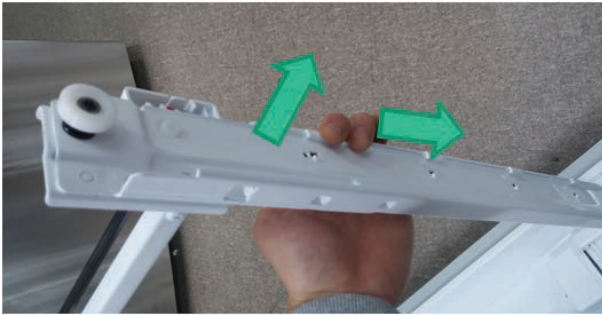

10. Loosen a screw.



8. Disassemble housing.



11. Disassemble Sensor from connector rail



9. Disassemble housing from cover.



3-21-1 PULL OUT DRAWER

1. Use a flat blade screwdriver to push the tab in on the left rail and push the tab on the right rail in with your finger. Once the tabs have been pushed in, you can lift the tray up and out.

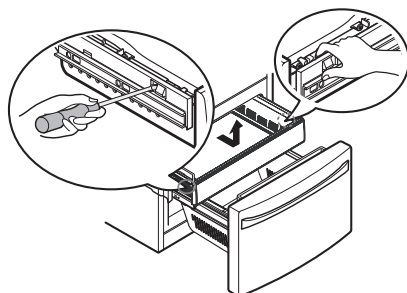

2. Pull both rails out to the full extension and insert the back of the tray into both rails. Then set the front of the tray into the rail and push it until you hear it click into place.

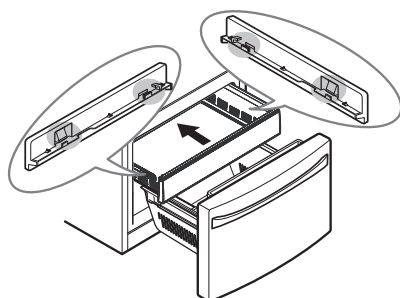

Middle Drawer

1. To remove the middle drawer.
Pull the drawer out to full extension. Lift the front of the drawer up, then pull it straight out.

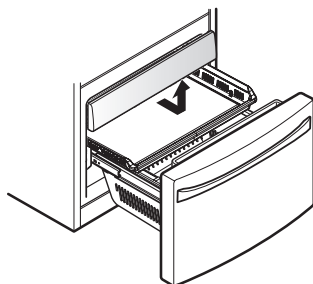

2. To install, slightly tilt up the front and insert the drawer into the frame and push it back into place.

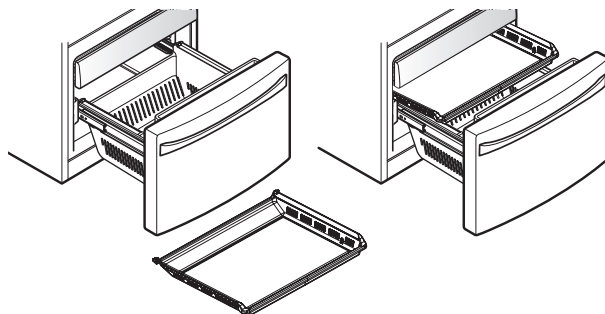

3-19 HOW TO REMOVE AND REINSTALL THE PULLOUT DRAWER

3-19-1 Follow Steps to Remove

Step 1) Open the freezer door.

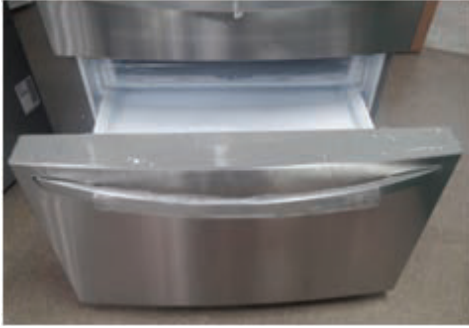

Step 2) Remove the lower basket.

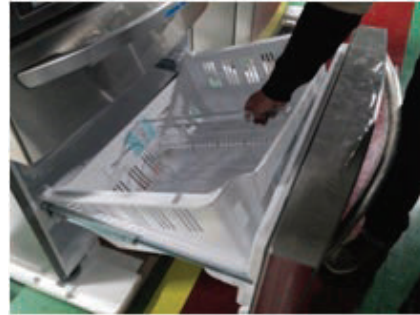

Step 3) Remove the two screws from the guide rails (one from each side).

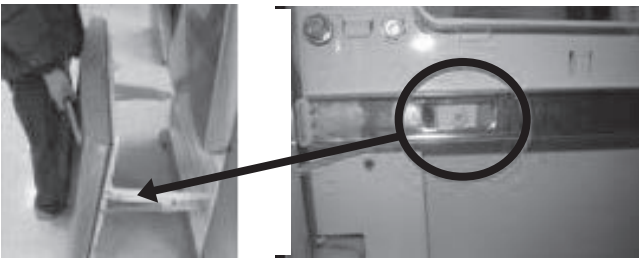

Step 4) Removal of the freezer door is done by lifting clear of the rail support. Fully extend both rails.



Step 5) Remove only 1 screw of gearice, and disassemble the bar and gearice



Step 6) Remove 2 screws of both side of supporter covers tv and disassemble the supporter cover tv.



3-19-2 Follow Steps to Reinstall

Step 1) Insert both side of supporter cover tv into connector rails, and then screw them.



Step 2) ① Assemble a bar and gear ice with screw.
② Push the otherside of the gear to inside of the bar.



Step 3) Put gear ice assembled with the bar by screw into connector rail's hole.



Step 4) Insert opposite gear ice into connector rail and screw them



Step 5) The rail system will align itself by pushing the rails all the way into the freezer section.
Pull the rails back out to full extension.

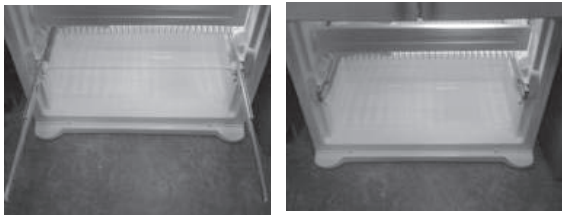

Step 6) Reinstall the freezer door by inserting the rail tabs into the guide rail.



Step 7) Reinstall the two screws into the guide rails
(one from each side).

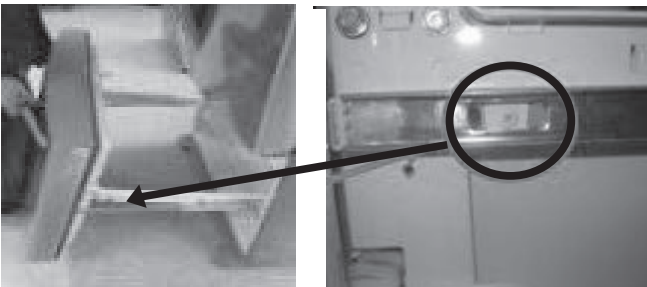

Step 8) Reinstall the lower basket, and close the freezer door.



3-22 WATER VALVE DISASSEMBLY METHOD

- 1) Turn off the water to unit. Remove the waterline from the valve.



- 2) Remove cover and 1 screw from the valve.

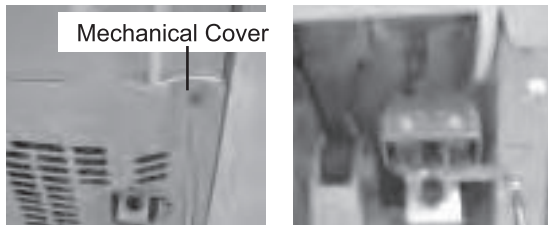

- 3) Separate the housing and remove the valve.



- 4) Remove the clip, and press the collet to separate the tube from the connector. Note: there maybe some water in the line.

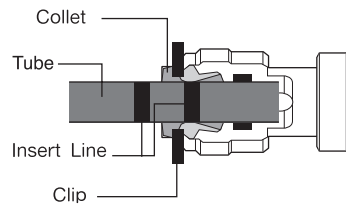
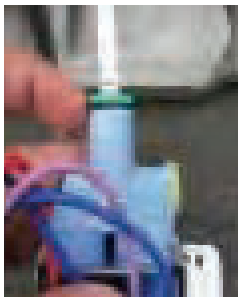

3-23 Fan motor assembly disassembly method

- 1) Remove screws for the Drain Pipe Assembly and the 1 connected to the Motor Cover.

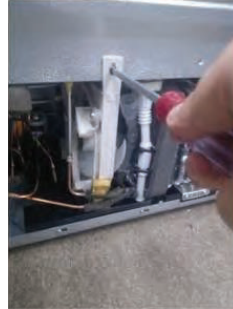

- 2) Remove the screw from shroud and Separate the Fan motor assembly and Shroud.



Assemble in reverse order. Taking care to avoid.

1. Do not to bend the tube during assembly.
2. Press the Water Dispenser button letting water pour out, this checks for any leaks in the tube connection, this may vary depending on the water pressure (about 2 minutes.).

3-24 CAUTION : Sealed System Repair

Before making a sealed system repair : Start with the power cord unplugged from the outlet. Plug in the power cord and between 6 and 12 seconds after it has been pugged in, unplug it from the power source. this will allow both sides of the 3 way valve to be opened to allow for proper evacuation.

3-25 Way Valve Service

■ The 3 way valve has plastic parts inside, so always wrap it with a wet cloth before servicing when using a torch.

- 1) Always replace the 3 way valve if there is a leak at any one of the 3 tubes coming from it.
- 2) Service in replacement of valve (valve failure) Perform service in the same method as above.

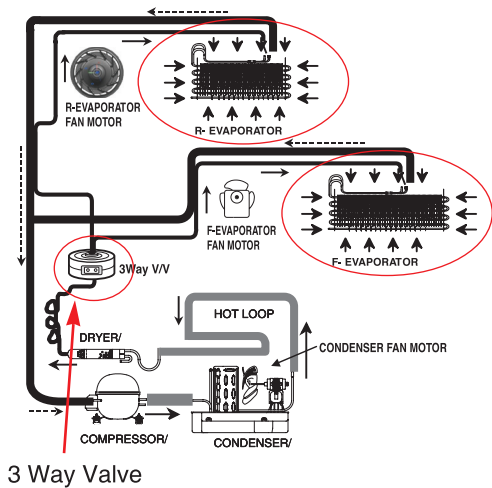

3 Way Valve

Whole picture of refrigerator

R-Evaporator



F-Evaporator

R-Evaporator



F-Evaporator



Note : To service sealed system, follow the directions in "3-22" and "3-23" above. Then service is the same as a single evaporator system.

4. ADJUSTMENT

4-1 COMPRESSOR

4-1-1 Role

The compressor intakes low temperature and low pressure gas from the evaporator of the refrigerator and compresses this gas to high-temperature and high-pressure gas. It then delivers the gas to the condenser.

4-1-2 Note for Usage

- (1) Be careful not to allow over-voltage and over-current.
- (2) Do not drop or handle carelessly.
- (3) Keep away from any liquid.
If liquid such as oil or water enters the Cover PTC Compressor may fail due to breakdown of their insulating capabilities.
- (4) Always use the Parts designed for the compressor and make sure it is properly attached to the compressor.
Parts may appear physically identical but could have different electrical ratings. Replace parts by part number and model number. Use only approved substitute parts.

4-1-3 Remove the cover PTC



(1) Remove the Cover Back M/C



(2) Remove two screws on comp base



- (3) Use a L-shaped flap tool to pry off the cover
- (4) Assembly in reverse order of disassembly

4-2-3 Compressor protection logic

- Since linear Comp conducts linear reciprocating motion, we have protection logic for compressor, motor and PCB as the below.

- Stroke Trip
During the operation, if stroke is above the target value, decrease the target volt by 3V.
- Current Trip
Current trip is set in order to protect compressor mechanical part and drive from the overcurrent that might arise during the operation.
Check the current for every 416.7us and if the Trip exceeds 1.86Arms more than three times at Comp ON, forcibly stop and restart six minutes later.
- Lock Piston Trip
If stroke is under 5mm even if the current is more than 14Arms, Take it as 'piston lock' and restart after 2'30" of Comp OFF. Check the current and stroke for every 416.7us and if the condition fits more than three times at Comp ON, the Trip occurs.
- IPM fault Trip
It occurs if FO signal received from IPM is LOW. For every 416.7us, check whether FO signal is LOW. The trip occurs if it is found three times during the five periods(83ms).

5. CIRCUIT DIAGRAM



MEZ65569801

*EARTH PART, REACTOR PART, F-LAMP, F-ROOM LED MODULE, PLUG TYPE AND COMP'EARTH PART, FUSE ON CIRCUIT DIAGRAM ARE SUBJECT TO CHANGE IN DIFFERENT LOCALITIES AND MODEL TYPE.

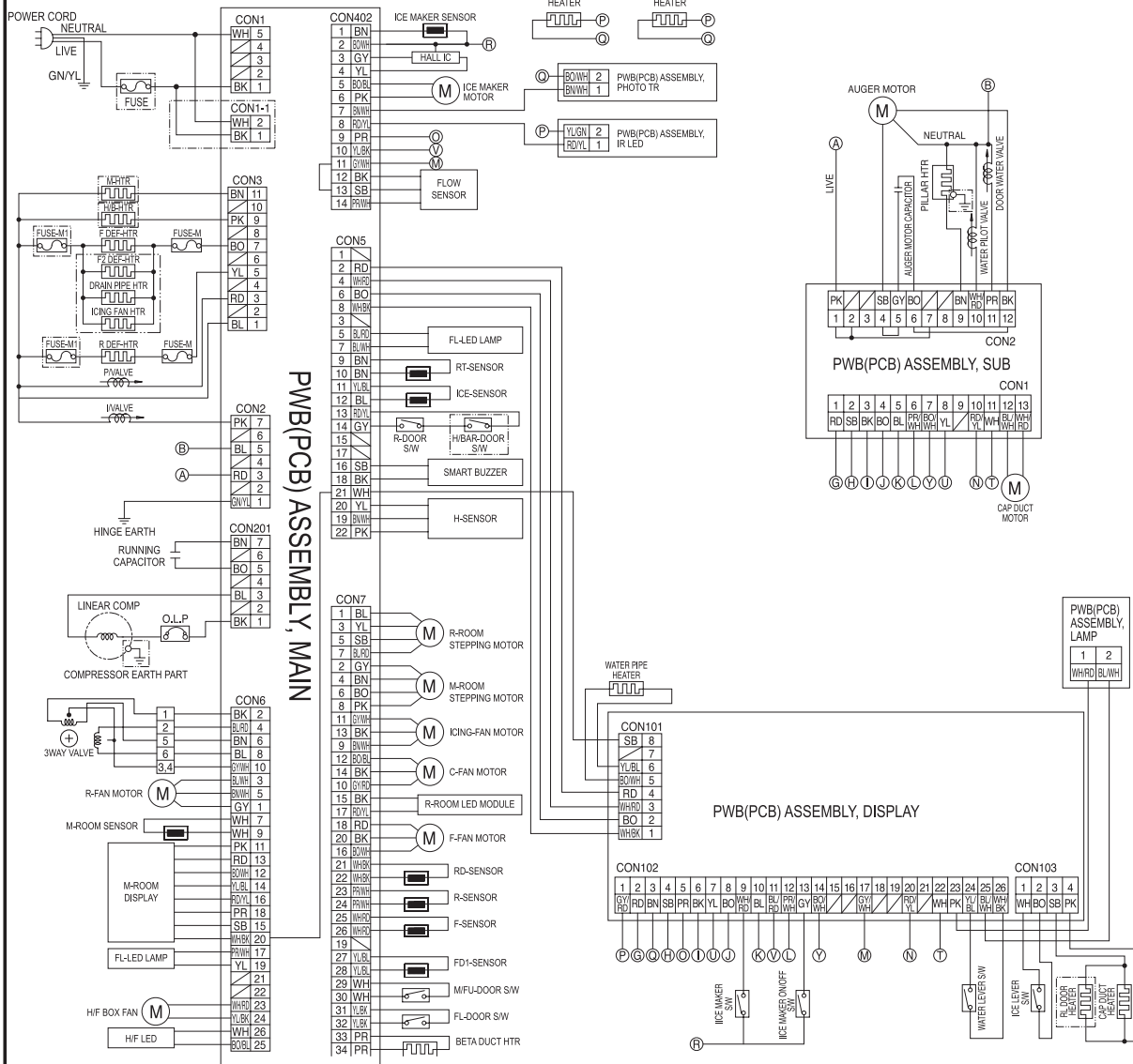

BK(BLACK) : NOIR	BL(BLUE) : BLEU	BN(BROWN) : MARRON	BO(BRIGHT ORANGE) : ORANGE BRILLANT	GY(GRAY) : GRIS	YL/BL(YELLOW/BLUE) : JAUNE/BLEU
YL(YELLOW) : JAUNE	GN(GREEN) : VERT	PR(PURPLE) : PURPLE	WH(WHITE) : BLANC	GY/RD(GRAY/RED) : GRIS/ROUGE	
SB(SKY BLUE) : BLEU/BLANC	PK(PINK) : ROSE	GN/YL(GREEN/YELLOW) : VERT/JAUNE	BL/WH(BLUE/WHITE) : BLEU/BLANC		
RD(RED) : ROUGE	WH/RD(WHITE/RED) : BLANC/ROUGE	BN/WH(BROWN/WHITE) : MARRON/BLANC	RD/YL(RED/YELLOW) : ROUGE/JAUNE		
WH/BK(WHITE/BLACK) : LANC/NOIR	YL/BK(YELLOW/BLACK) : JAUNE/NOIR	PR/WH(PURPLE/WHITE) : VIOLET/BLANC	BL/RD(BLUE/RED) : BLEU/ROUGE		
RD/WH(RED/WHITE) : ROUGE/BLANC	GY/WH(GRAY/WHITE) : GRIS /BLANC	BO/BL(BRIGHT ORANGE/BLUE) : ORANGE BRILLANT/BLEU	GY/RD(GRAY/RED):GRIS/ROUGE		

6. TROUBLESHOOTING

6-1 Error Code Summary

▲ WARNING: When checking Resistance values, make sure to turn off the power, and wait for the voltage to discharge.

NOTE) Within 3 hours after the error : Press the Ice Plus button and Freezer button simultaneously. All errors, except for “E rt”, “E SS”, “E HS”, “E IS(except for Icing sensor)”. “E gF”, “E It” error, are displayed.
“E IS” which is displayed without input of user is the error of Icing Sensor.

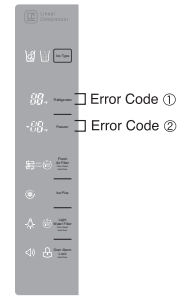

NO	Error Detection Category	Error Display		Error Generation Factors	Remark
		Refrigerator Temperature (Error code ①)	Freezer Temperature (Error code ②)		
1	Normality			None	Normal operation of Display
2	Freezer Sensor Error	Er	FS	Short or Disconnection of Freezer Sensor	Check Each sensor and its Connector.
3	Refrigerator Sensor Error	Er	rS	Short or Disconnection of Refrigerator Sensor	
4	Freezer Defrost Sensor Error	F	dS	Short or Disconnection Of Defrost Sensor	
5	Refrigerator Defrost Sensor Error	r	dS	Short or Disconnection Of Defrost Sensor	
6	Humidity Sensor Error	Er	HS	Short or Disconnection Of Humidity	
7	Icing Sensor Error	Er	IS	Short or disconnection of the sensor about Ice maker (Icing sensor, Ice maker sensor)	
8	Pantry sensor error	Er	SS	Short or Disconnection of Pantry Sensor	
9	Room Temp Sensor Error	Er	rt	Short or Disconnection of Room temp.sensor	
10	Ice maker kit defect	Er	It	Other Electric system error such as moter, gear, Hall,IC operation circuit within I/M kit	
11	Flow Meter(Sensor) Defect	Er	gF	Error of flow meter or water input or low water pressure	Error of flow meter or water input or low water pressure or flow meter connection
12	Freezer Defrosting Error	F	dH	Even though it is passed 80Minute since then Defrosting, If Defrosting sensor is not Over 40°F(5°C), it is caused	Temperature Fuse Disconnection, Heater Disconnection, DRAIN Jam, Poor Relay for Heater
13	Refrigerator Defrosting Error	r	dH	Even though it is passed 50Minute since then Defrosting, If Defrosting sensor is not Over 40°F(5°C), it is caused	
14	Abnormality of BLDC FAN Motor for Ice Making	Er	IF	It is caused when feedback signal isn't over 65 seconds during BLDC FAN motor operating	Poor BLDC Motor connection, DRIVE IC, and TR
15	Abnormality of BLDC FAN Motor for Freezer	Er	FF	It is caused when feedback signal isn't over 65 seconds during BLDC FAN motor operating	Poor BLDC Motor connection, DRIVE IC, and TR

NO	Error Detection Category	Error Display		Error Generation Factors	Remark
		Refrigerator Temperature (Error code ①)	Freezer Temperature (Error code ②)		
16	Abnormality of BLDC FAN MOTOR For Refrigerator	Er	rF	It is caused when feedback signal isn't over 65 seconds during BLDC FAN motor operating	Poor BLDC Motor connection, DRIVE IC, and TR
17	Abnormality of BLDC FAN Motor for Mechanic Room	Er	CF	It is caused when feedback signal isn't over 65 seconds during BLDC FAN motor operating	Poor BLDC Motor connection, DRIVE IC, and TR
18	Communication Error	Er	CO	Communication Error between Micom of Main PCB and Display Micom	Poor Communication connection, Poor TR of Transmitter and Receiver Tx/Rx between display and main board.

7. PCB PICTURE

7-1 Main PCB

(P/N : EBR78643401)

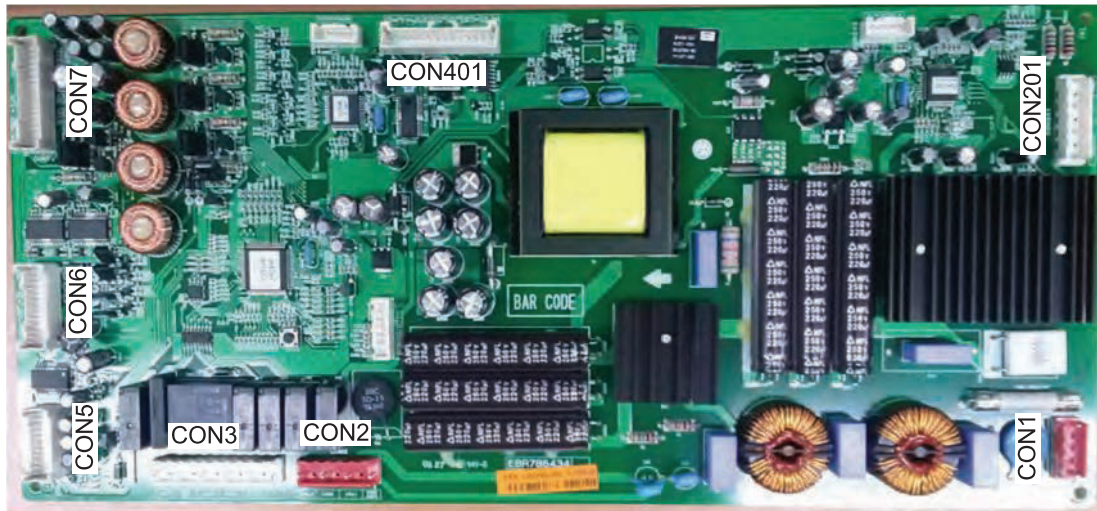

7-2. Display PCB

(P/N : EBR72955422)



7-3. Sub PCB

(P/N : EBR76468402)

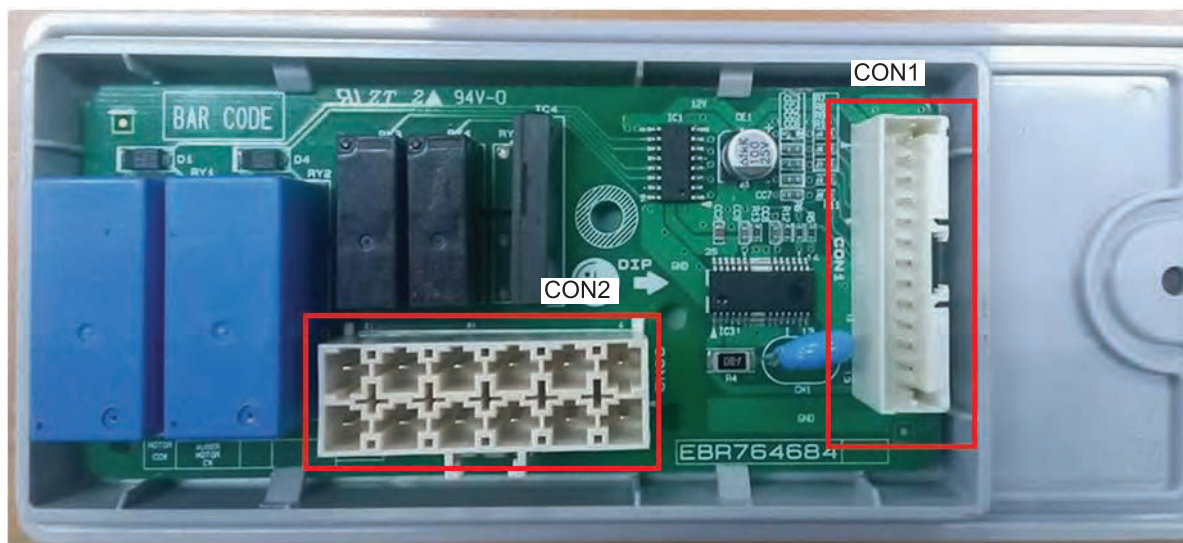

8. Troubleshooting With Error Display

8-1. Freezer Sensor Error (E FS)

Symptom	Check Point
1. E FS	1. Check for a loose connection 2. Check Sensor Resistance

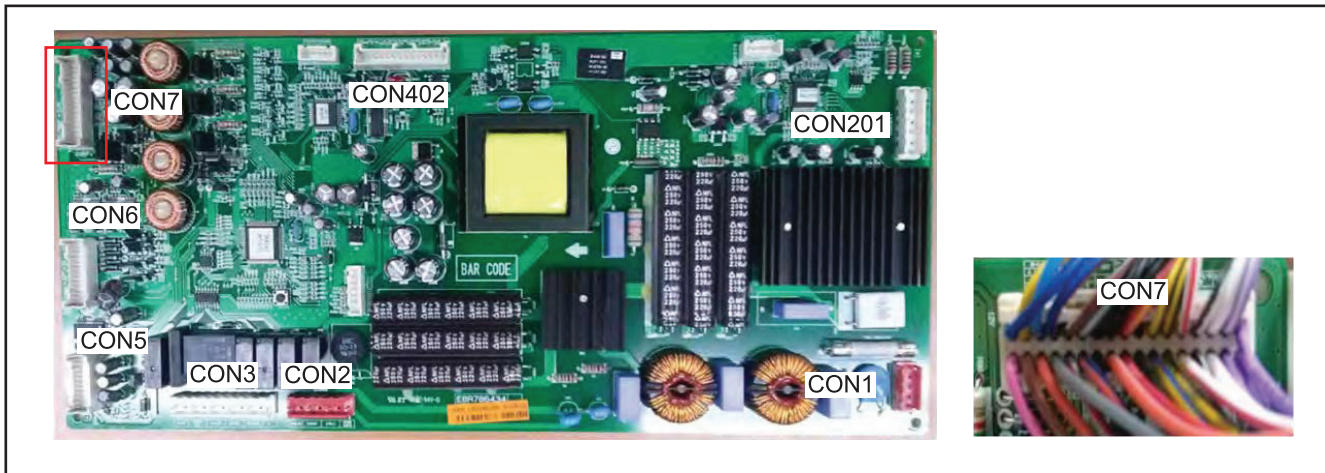

CON7	Resistance [Ω]		
	CON7 25 th pin ~26 th pin	Short	0
		Open	OFF
	Other	Normal	

CON7 25 th pin ~26 th pin	Resistance [Ω]
-22°F / -30°C	40k
-13°F / -25°C	30k
-4°F / -20°C	23k
-13°F / -25°C	17k
14°F / -10°C	13k
23°F / -5°C	10k
32°F / 0°C	8k

Freezer Sensor Error (E FS)

1
Is the Connector disconnected or loose between Main PCB and sensor?

Yes → Reconnect or repair the connector

No → 2

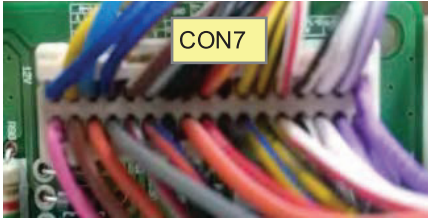

4
Check the Sensor resistance. Is resistance normal?

Yes → 5

2
Check the Sensor resistance. Is resistance 0 Ω (Sensor short)?

Yes → Change the Sensor

No → 3

3
Check the Sensor resistance. Is resistance OFF (Sensor open)?

Yes → Replace the refrigerator

No → 6

5
Check the Temperature and resistance refer to the table. No problem?

Yes → 6

CON7 25 th pin ~ 26 th pin	Resistance [Ω]
-22°F / -30°C	40k
-13°F / -25°C	30k
-4°F / -20°C	23k
-13°F / -25°C	17k
14°F / -10°C	13k
23°F / -5°C	10k
32°F / 0°C	8k

6
Explain to customer

8-2. Refrigerator Sensor Error (E rS)

Symptom	Check Point
1. E rS	1. Check for a loose connection 2. Check Sensor Resistance

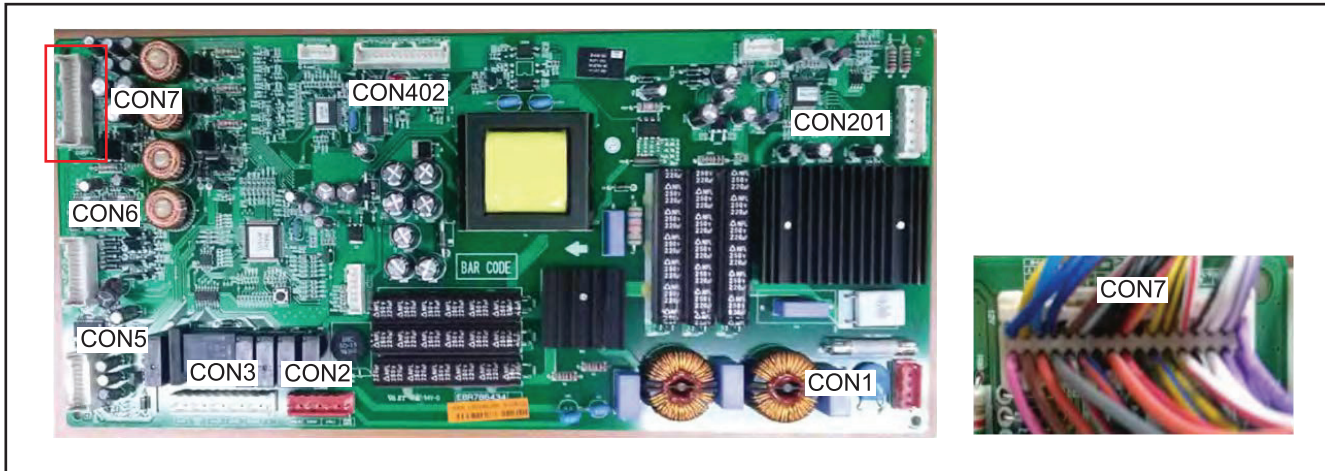

		Resistance [Ω]	
CON7 23 th pin ~24 th pin	Short	0	
	Open	OFF	
	Other	Normal	

CON7 23 th pin ~24 th pin	Resistance [Ω]
23°F / - 5°C	38k
32°F / 0°C	30k
41°F / 5°C	24k
50°F / 10°C	19.5k
59°F / 15°C	16k

Refrigerator Sensor Error (E rS)

1
Is the Connector disconnected or loose between Main PCB and sensor?

Yes → Reconnect or repair the connector

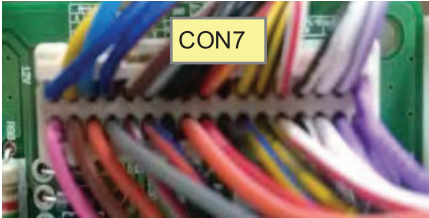

No → [Proceeds to Step 2]

2
Check the Sensor resistance. Is resistance 0 Ω (Sensor short)?

Yes → Change the Sensor

No → [Proceeds to Step 3]

3
Check the Sensor resistance. Is resistance OFF (Sensor open)?

Yes → Replace the refrigerator

No → [Proceeds to Step 4]

4
Check the Sensor resistance. Is resistance normal?

Yes → [Proceeds to Step 5]

5
Check the Temperature and resistance refer to the table. No problem?

CON7 23 th pin ~ 24 th pin	Resistance [Ω]
23°F / -5°C	38k
32°F / 0°C	30k
41°F / 5°C	24k
50°F / 10°C	19.5k
59°F / 15°C	16k

Yes → [Proceeds to Step 6]

6
Explain to customer

8-3. Icing Sensor Error (E IS)

Symptom	Check Point
1. E IS	1. Check for a loose connection 2. Check Sensor Resistance

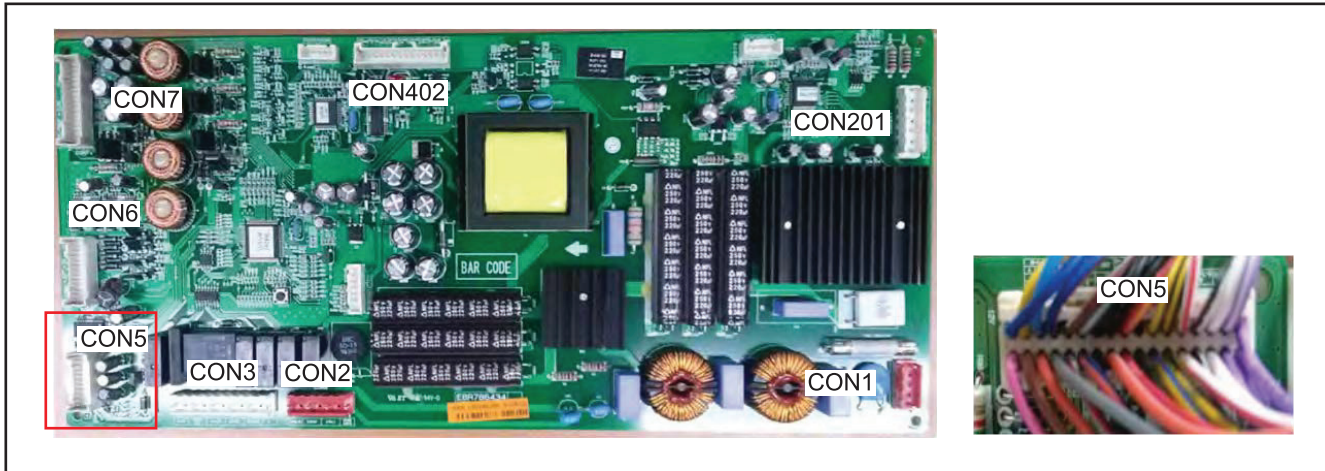

	Resistance [Ω]		
	CON5 11 th pin ~12 th pin	Short	0
		Open	OFF
	Other	Normal	

CON5 11 th pin ~12 th pin	Resistance [Ω]
-22°F / -30°C	40k
-13°F / -25°C	30k
-4°F / -20°C	23k
-13°F / -25°C	17k
14°F / -10°C	13k
23°F / -5°C	10k
32°F / 0°C	8k

Icing Sensor Error (E IS)

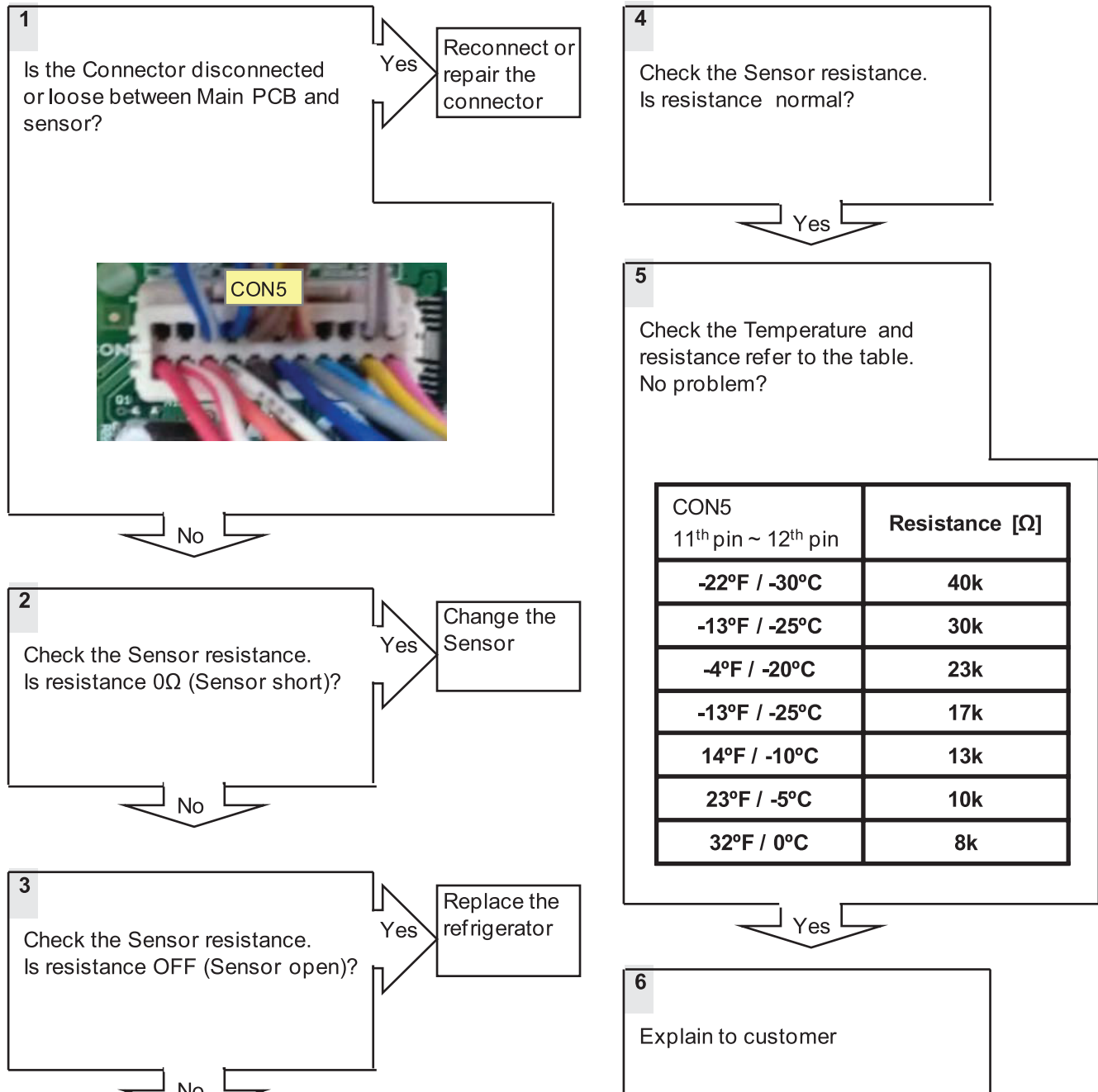

8-4. Defrost Sensor Error (F dS)

Symptom	Check Point
1. F dS	1. Check for a loose connection 2. Check Sensor Resistance

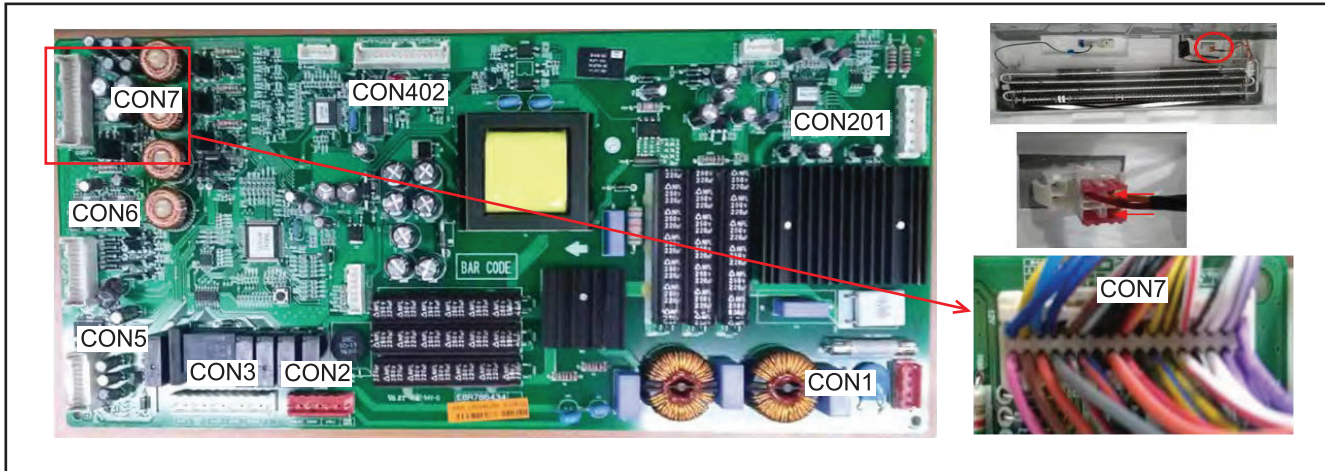

	Resistance [Ω]		
	CON7 27 th pin ~28 th pin	Short	0
		Open	OFF
	Other	Normal	

CON7 27 th pin ~28 th pin	Resistance [Ω]
23°F / -5°C	38k
32°F / 0°C	30k
41°F / 5°C	24k
50°F / 10°C	19.5k
59°F / 15°C	16k

Defrost Sensor Error (F dS)

1
Is the Connector disconnected or loose between Main PCB, Sensor?

Yes → Reconnect or repair the connector

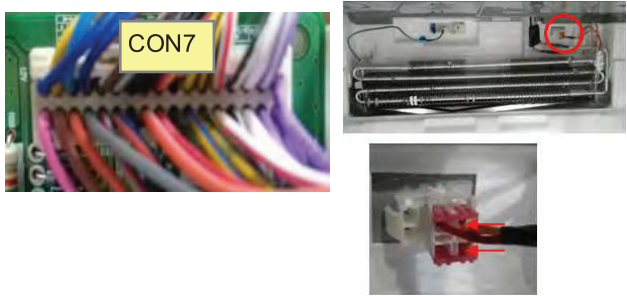

No → [Proceeds to Step 2]

2
Check the Sensor resistance. Is resistance 0Ω (Sensor short)?

Yes → Change the Heater (including Sensor)

No → [Proceeds to Step 3]

3
Check the Sensor resistance. Is resistance OFF (Sensor open)?

Yes → Replace the refrigerator

No → [Proceeds to Step 4]

4
Check the Sensor resistance. Is resistance normal?

Yes → [Proceeds to Step 5]

5
Check the Temperature and resistance refer to the table. No problem?

CON7 27 th pin ~ 28 th pin	Resistance [Ω]
23°F / -5°C	38k
32°F / 0°C	30k
41°F / 5°C	24k
50°F / 10°C	19.5k
59°F / 15°C	16k

Yes → [Proceeds to Step 6]

6
Explain to customer

8-5. Defrost Sensor Error (r dS)

Symptom	Check Point
1. r dS	1. Check for a loose connection 2. Check Sensor Resistance

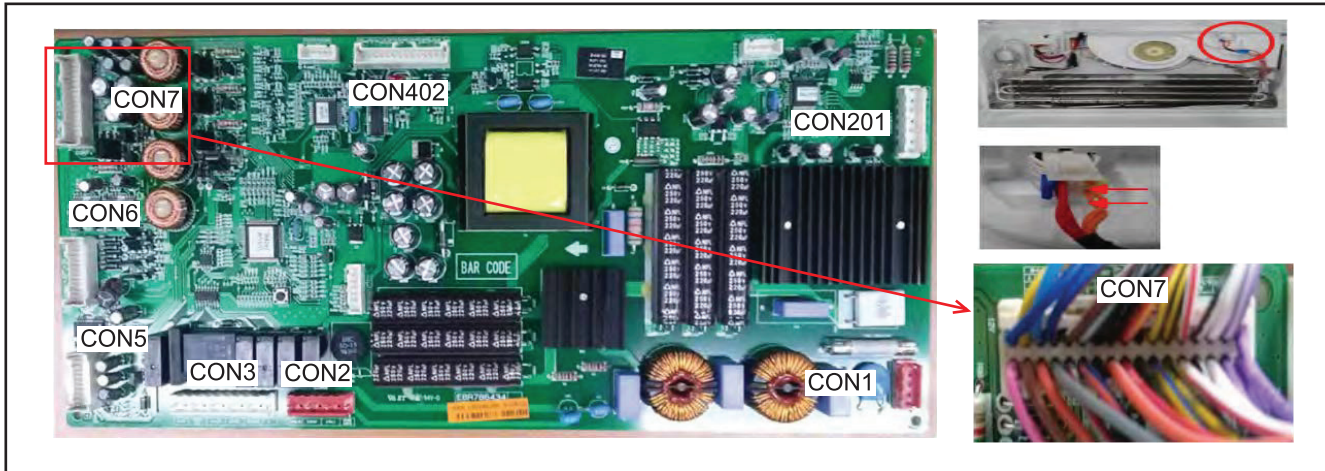

CON7	Resistance [Ω]	Resistance [Ω]	
		Short	0
CON7 21 th pin ~22 th pin	Open	OFF	
	Other	Normal	

CON7 21 th pin ~22 th pin	Resistance [Ω]
23°F / -5°C	38k
32°F / 0°C	30k
41°F / 5°C	24k
50°F / 10°C	19.5k
59°F / 15°C	16k

CON7	Component
1	BL
3	YL
5	SB
7	BLRD
2	GY
4	BN
6	BO
8	PK
11	BYMG
13	BK
9	BYMG
12	BOBU
14	BK
10	BYRB
15	BK
17	RDYI
18	RD
20	BK
16	BYMG
21	ANBR
22	ANBR
23	PNBR
24	PNBR
25	WRRL
26	WRFL
19	
27	YLR
28	YLR
29	WH
30	WH
31	YLR
32	YLR
33	PR
34	PR

Defrost Sensor Error (r dS)

1
Is the Connector disconnected or loose between Main PCB, Sensor?

Yes → Reconnect or repair the connector

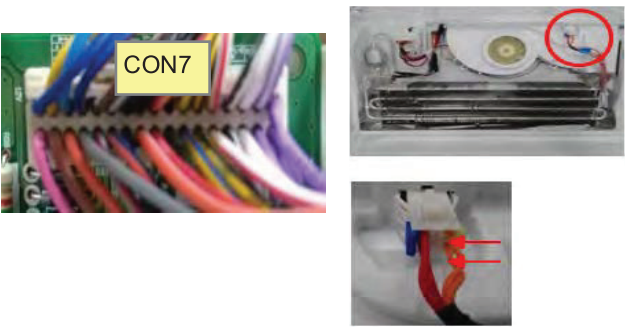

No → 2

2
Check the Sensor resistance. Is resistance 0Ω (Sensor short)?

Yes → Change the Heater (including Sensor)

No → 3

3
Check the Sensor resistance. Is resistance OFF (Sensor open)?

Yes → Replace the refrigerator

No → 4

4
Check the Sensor resistance. Is resistance normal?

Yes → 5

5
Check the Temperature and resistance refer to the table. No problem?

CON7 21 th pin ~ 22 th pin	Resistance [Ω]
23°F / -5°C	38k
32°F / 0°C	30k
41°F / 5°C	24k
50°F / 10°C	19.5k
59°F / 15°C	16k

Yes → 6

6
Explain to customer

8-6. Defrost Heater Error (F dH)

Symptom	Check Point
1. F dH	1. Check the door gasket 2. Check the Heater, Sensor Part 3. Check the PCB output voltage

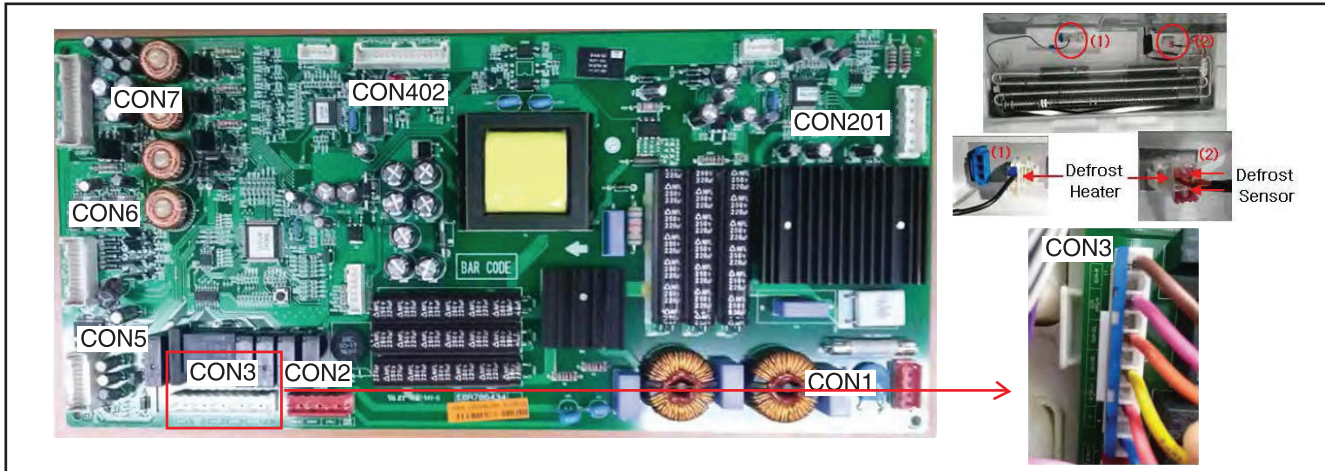

Part	Result	SVC Action
Defrost Heater	36~42Ω	Go to next step
	Other	Change Defrost Heater
Def' Sensor	normal	Go to next step
	Other	Change Defrost Heater (Including Def' Sensor)

TEST MODE 3	Voltage [V]
CON3 1 th pin ~ 7 th pin	112V ~ 116V

TEST MODE 1	Voltage [V]
CON3 1 th pin ~ 7 th pin	0V

Defrost Sensor	Resistance [Ω]
23°F / -5°C	38k
32°F / 0°C	30k
41°F / 5°C	24k
50°F / 10°C	19.5k
59°F / 15°C	16k

Defrost Heater Error (F dH)

1 Check the Door gasket .
Is door gasket damaged?

Yes → Replace the Door gasket

No → 2

2 Check the Heater Part.
Is Heater resistance 36~42 Ω?

Defrost Heater (1) Defrost Sensor (2)

No → Replace Heater

Yes → 3

3 Check the Defrost Sensor part.
Is Defrost Sensor resistance Normal?

Defrost Heater (1) Defrost Sensor (2)

No → Replace Heater (Including Sensor)

Yes → 4

4 Input Test 3 Mode
(Push the button 3 times)
Check the Heater Voltage.
Is voltage 112~116V?

Yes → Replace Main PCB

TEST MODE 3	Voltage [V]
CON3 1 ^h pin ~ 7 th pin	112V ~ 116V

Yes → 5

5 Input Test 1 Mode
(Push the button 1 times)
Check the Heater Voltage.
Is voltage 0V?

No → Replace Main PCB

TEST MODE 1	Voltage [V]
CON3 1 th pin ~ 7 th pin	0V

Yes → 6

6 Explain to customer

8-7. Defrost Heater Error (r dH)

Symptom	Check Point
1. r dH	1. Check the door gasket 2. Check Heater, Sensor Part 3. Check the PCB output voltage

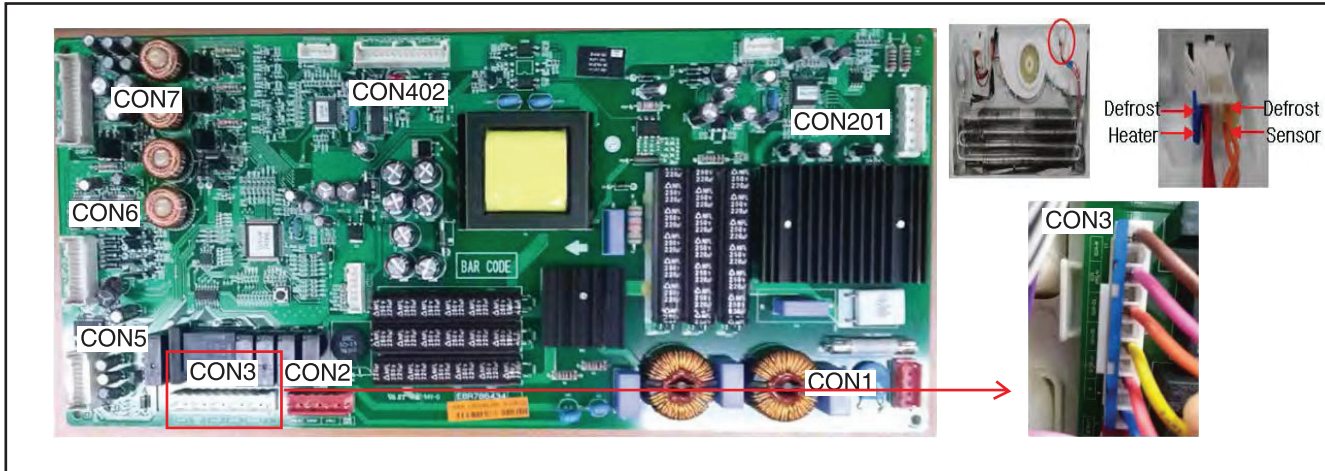

Part	Result	SVC Action
Defrost Heater	82.6~91.4Ω	Go to next step
	Other	Change Defrost Heater
Def' Sensor	Normal	Go to next step
	Other	Change Defrost Heater (Including Def' Sensor)

TEST MODE 3	Voltage [V]
CON3 1 th pin ~ 5 th pin	112V ~ 116V

TEST MODE 1	Voltage [V]
CON3 1 th pin ~ 5 th pin	0V

Defrost Sensor	Resistance [Ω]
23°F / -5°C	38k
32°F / 0°C	30k
41°F / 5°C	24k
50°F / 10°C	19.5k
59°F / 15°C	16k

Defrost Heater Error (r dH)

1 Check the Door gasket .
Is door gasket damaged?

Yes → Replace the Door gasket

No → 2

2 Check the Heater Part
Is Heater resistance 82.6~91.4 ?

No → Replace Heater

Yes → 3

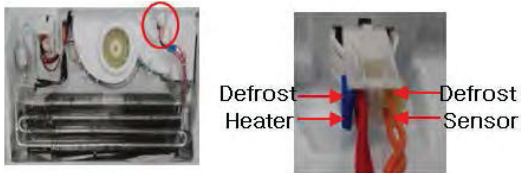

3 Check the Defrost Sensor part.
Is Defrost Sensor resistance Normal?

No → Replace Heater (Including Sensor)

Yes → 6

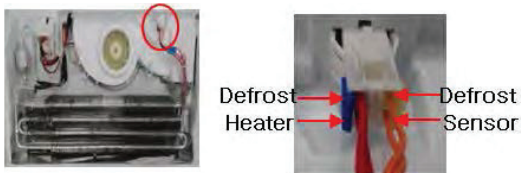

4 Input Test 3 Mode
(Push the button 3 times)
Check the Heater Voltage.
Is voltage 112~116V?

Yes → Replace Main PCB

No → 5

TEST MODE 3	Voltage [V]
CON3 1 th pin ~ 5 th pin	112V ~ 116V

5 Input Test 1 Mode
(Push the button 1 times)
Check the Heater Voltage.
Is voltage 0V?

No → Replace Main PCB

Yes → 6

TEST MODE 1	Voltage [V]
CON3 1 th pin ~ 5 th pin	0V

6 Check the Ice fan haater Part
Is heater resistance 2976~3424Ω?

8-8. Refrigerator Fan Error (E rF)

Symptom	Check Point
1. E rF	1. Check the air flow 2. Check the PCB Fan motor voltage

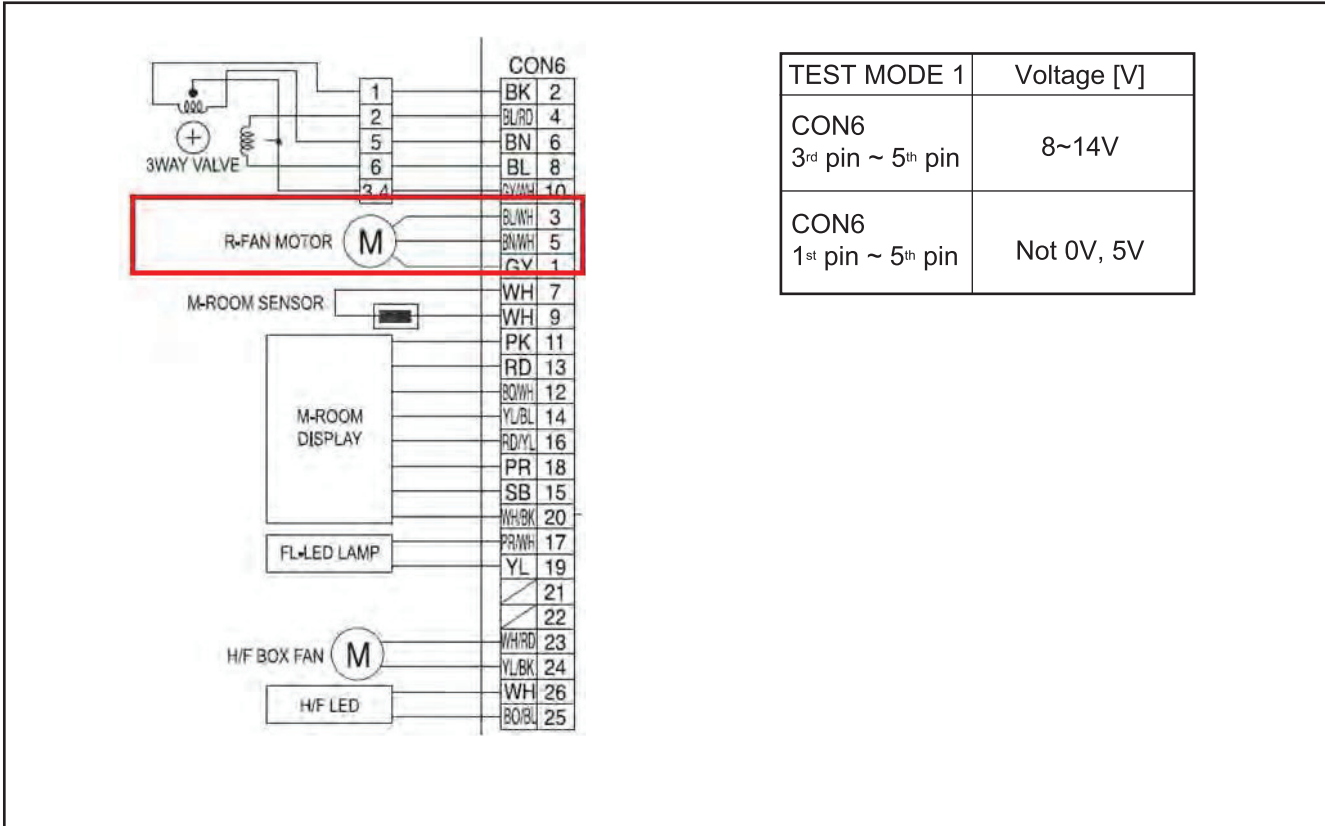
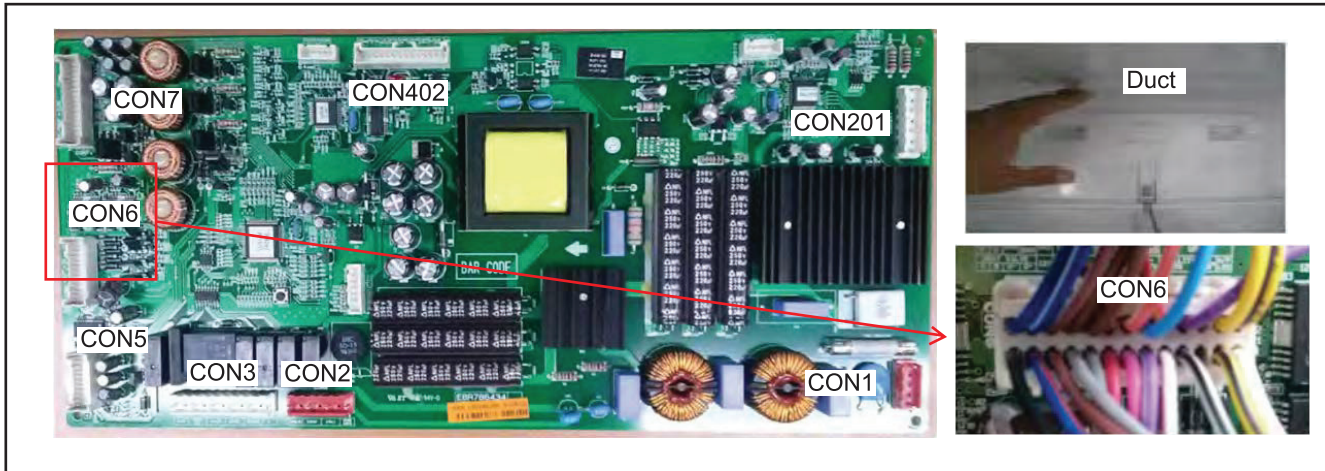

Refrigerator Fan Error (E rF)

1 Reset the unit and Input Test1 Mode. (Push the button 1 time)



2 Open the freezer door and Check the air flow. Windy?



No → Go to 3

Yes → Go to 4

3 Check the Fan motor. Rotate fan using hand. It feel sticky?

Yes → Change the Fan motor



Fan Motor

4 Check the Fan Motor voltage Is Fan Motor voltage 8~12V?

No → Replace Main PCB

TEST MODE 1	Voltage [V]
CON6 3 rd pin ~ 5 th pin	8~14V

Yes → Go to 5

5 Check the Fan Motor voltage Is Fan Feed Back voltage 0V, 5V?

Yes → Change the motor

TEST MODE 1	Voltage [V]
CON6 1 st pin ~ 5 th pin	Not 0V, 5V

No → Go to 6

6 Explain to customer

8-9. Freezer Fan Error (E FF)

Symptom	Check Point
1. E FF	<ol style="list-style-type: none"> 1. Check the air flow 2. Check the Fan Motor 3. Check the PCB Fan motor voltage 4. Check the Ice Fan heater

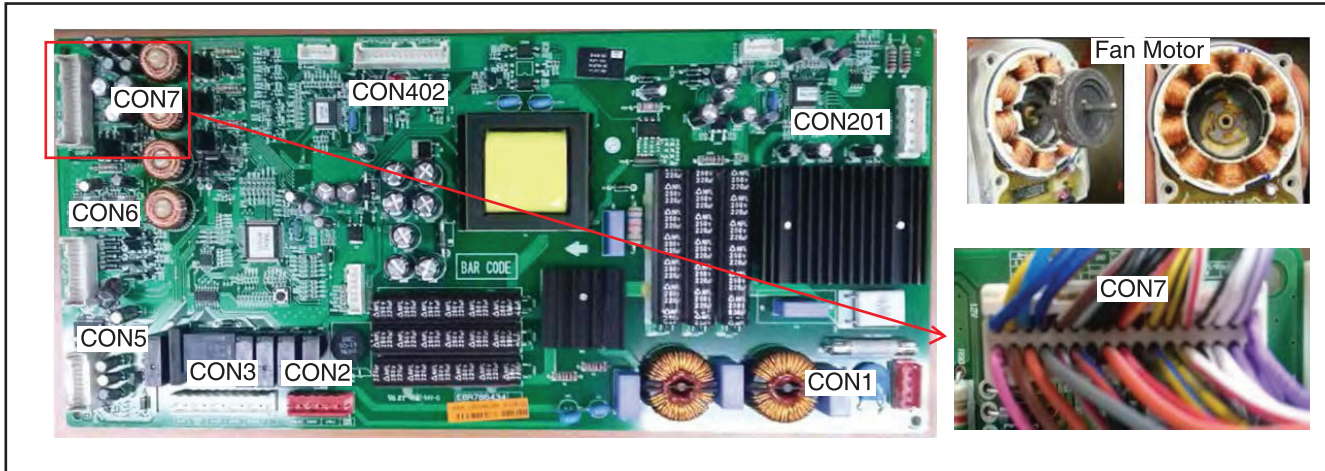

TEST MODE 1	Voltage [V]
CON6 18 th pin ~ 20 th pin	8~14V
CON6 16 th pin ~ 20 th pin	Not 0V, 5V

CON7	Pin	Color	Component	
M	1	BL	R-ROOM STEPPING MOTOR	
	3	YL		
	5	SB		
	7	BLRD		
	M	2	GY	M-ROOM STEPPING MOTOR
		4	BN	
		6	BO	
	M	8	PK	I-ROOM FAN MOTOR
		11	GYW	
	M	13	BK	I-ROOM FAN MOTOR
		9	GYW	
	M	12	BO	C-FAN MOTOR
		14	BK	
		10	GYRD	
		15	BK	R-ROOM LED MODULE
		17	ROY	
	M	18	RD	F-FAN MOTOR
20		BK		
16		ROY		
	21	W/BK	RD-SENSOR	
	22	W/BK		
	23	P/W	R-SENSOR	
	24	P/W		
	25	W/R	F-SENSOR	
	26	W/R		
	19			
	27	V/B	FD1-SENSOR	
	28	Y/B		
	29	WH	MFU-DOOR SW	
	30	WH		
	31	N/BK	FL-DOOR SW	
	32	N/BK		
	33	PR	BETA DUCT HTR	
	34	PR		

Freezer Fan Error (E FF)

1 Reset the unit and Input Test1 Mode. (Push the button 1 time)



2
Open the freezer door and Check the air flow. Windy?



No
Go to 3

Yes
Go to 4

3
Check the Fan motor. Rotate fan using hand. It feel sticky?

Fan Motor

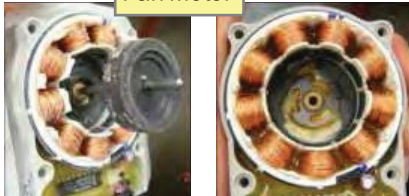

Yes
Change the Fan motor

4
Check the Fan Motor voltage
Is Fan Motor voltage 8~12V?

No
Replace Main PCB

TEST MODE 1	Voltage [V]
CON7 18 th pin ~ 20 th pin	8~14V

Yes
Go to 5

5
Check the Fan Motor voltage
Is Fan Feed Back voltage 0V, 5V?

Yes
Change the motor

TEST MODE 1	Voltage [V]
CON7 16 th pin ~ 20 th pin	Not 0V, 5V

No
Go to 6

6
Explain to customer

8-10. Icing Fan Error (E IF)

Symptom	Check Point
1. E IF	1. Check the air flow 2. Check the Connector 2. Check the PCB Fan motor voltage

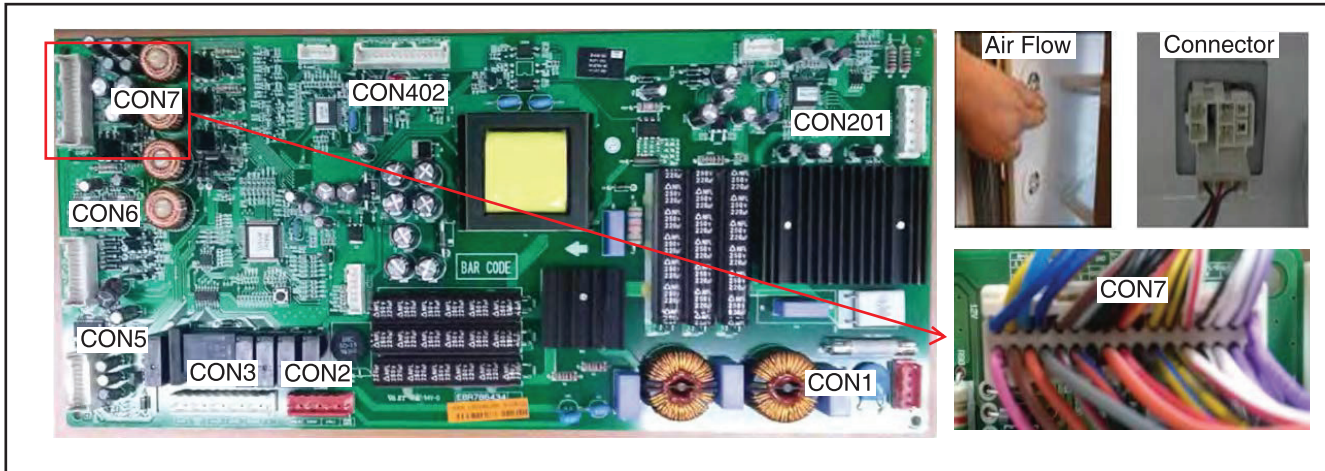

	<table border="1"> <thead> <tr> <th>TEST MODE 1</th> <th>Voltage [V]</th> </tr> </thead> <tbody> <tr> <td>CON7 11rd pin ~ 13th pin</td> <td>8~14V</td> </tr> <tr> <td>CON7 9st pin ~ 13th pin</td> <td>Not 0V, 5V</td> </tr> </tbody> </table>	TEST MODE 1	Voltage [V]	CON7 11 rd pin ~ 13 th pin	8~14V	CON7 9 st pin ~ 13 th pin	Not 0V, 5V
TEST MODE 1	Voltage [V]						
CON7 11 rd pin ~ 13 th pin	8~14V						
CON7 9 st pin ~ 13 th pin	Not 0V, 5V						

I/fan heater Connector

Part	Result	SVC Action
Ice fan heater	2976~3424 Ω	Go to next step
	Other	Change Ice fan Motor assembly

Freezer Fan Error (E IF)

1 Reset the unit and Input Test1 Mode. (Push the button 1 time)



2 Open the freezer door and Check the air flow. Windy?



Yes
Go to 4

3 Check the Fan motor. Rotate fan using hand. It feel sticky?

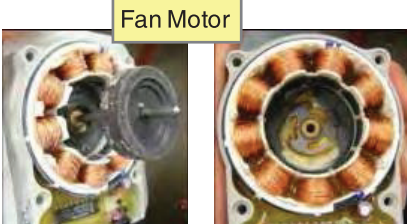

Yes
Change the Fan motor

4 Check the Fan Motor voltage Is Fan Motor voltage 8~12V?

TEST MODE 1	Voltage [V]
CON7 11 rd pin ~ 13 th pin	8~14V

No
Replace Main PCB

5 Check the Fan Motor voltage Is Fan Feed Back voltage 0V, 5V?

TEST MODE 1	Voltage [V]
CON7 9 st pin ~ 13 th pin	Not 0V, 5V

Yes
Change the motor

6 Check the Ice fan heater Part. Is heater resistance 2976~3424 Ω ?

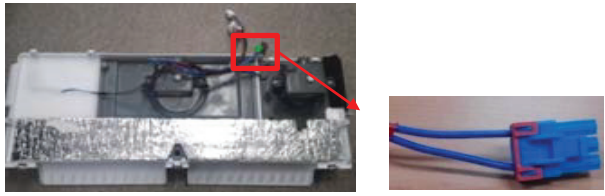

No
Replace Ice fan motor assembly

7 Explain to customer

8-11. Condenser Fan Error (E CF)

Symptom	Check Point
1. E CF	1. Check the air flow 2. Check the Connector 2. Check the PCB Fan motor voltage

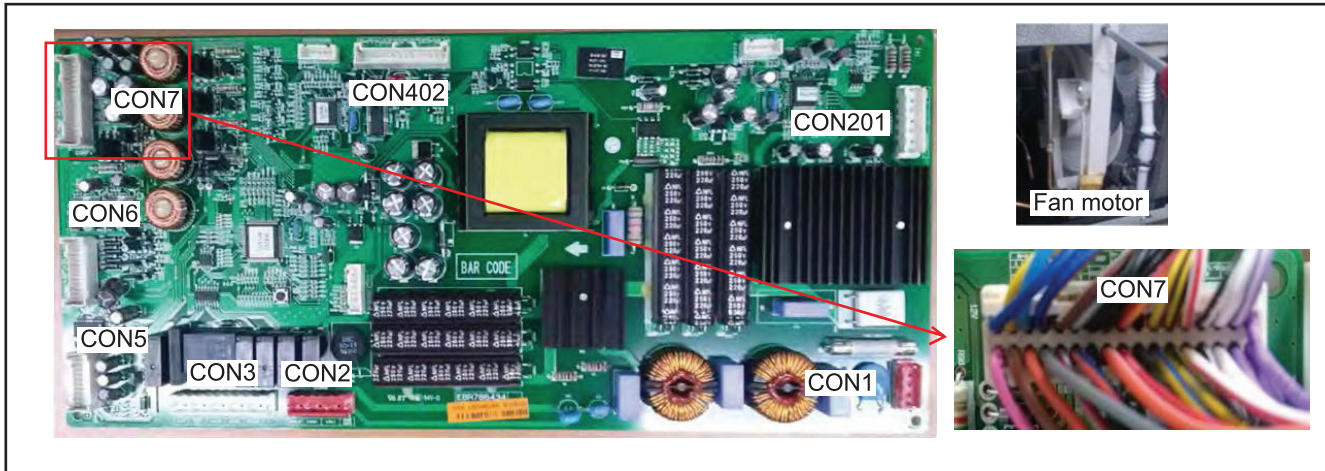

CON7	TEST MODE 1	Voltage [V]
1 BL	CON7 12 th pin ~ 14 th pin	8~14V
3 YL		
5 SB	CON7 10 st pin ~ 14 th pin	Not 0V, 5V
7 BR		
2 BY		
4 BN		
6 BO		
8 PK		
11 BW		
13 BK		
12 BO/BL		
14 BK		
10 BR/BL		
15 BA		
17 BR/YL		
18 RD		
20 BK		
16 BR/BL		
21 BR/BL		
22 BR/BL		
23 BR/BL		
24 BR/BL		
25 BR/BL		
26 BR/BL		
19		
27 YL/BL		
28 YL/BL		
29 WH		
30 WH		
31 YL/BL		
32 YL/BL		
33 PR		
34 PR		

Condenser Fan Error (E CF)

1 Reset the unit and Input Test1 Mode. (Push the button 1 time)



2 Check the fan rotating. Does fan rotate?

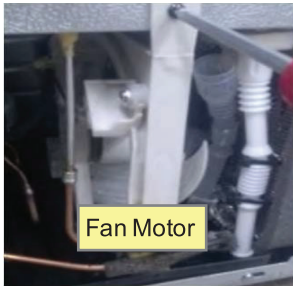

No
Go to 3

Yes

Go to 4

3 Check the Fan motor. Rotate fan using hand. It feel sticky?

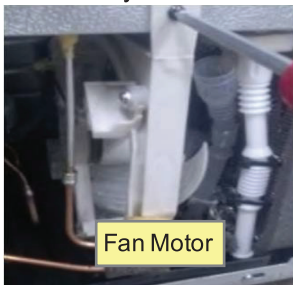

Yes
Change the Fan motor

4 Check the Fan Motor voltage Is Fan Motor voltage 8~12V?

No
Replace Main PCB

TEST MODE 1	Voltage [V]
CON7 12 th pin ~14 th pin	8~14V

Yes

5 Check the Fan Motor voltage Is Fan Feed Back voltage 0V, 5V?

Yes
Change the motor

TEST MODE 1	Voltage [V]
CON7 10 th pin ~14 th pin	Not 0V, 5V

No

6
Explain to customer

8-12. Communication Error (E CO)

Symptom	Check Point
1. E CO	1. Check the loose connection 2. Check the Hinge connection

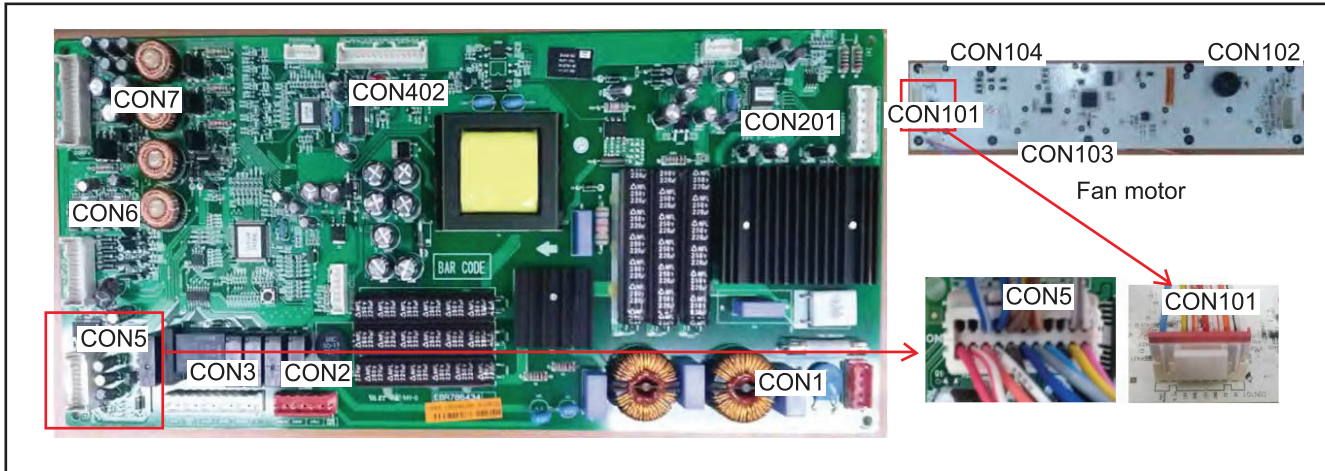

		Voltage [V]
CON101	3 rd pin ~ 4 th pin	12V
CON101	2 nd pin ~ 3 rd pin	Not 0V, 5V
CON101	1 st pin ~ 3 rd pin	Not 0V, 5V
CON5	4 th pin ~ 6 th pin	Not 0V, 5V
CON5	4 th pin ~ 8 th pin	Not 0V, 5V

Communication Error (E CO)

1
Check the loose connection

2
Check the voltage.
Is CON101 3rd pin ~ 4th pin
voltage 12V?

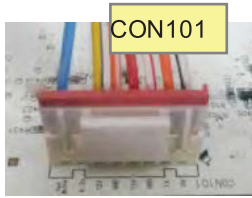

	Voltage [V]
CON101 3 rd pin ~ 4 th pin	12V

No
Check the Hinge (loose connection)
Change the Main PCB

3
Check the voltage.
Is CON101 2nd pin ~ 3rd pin
voltage 0V or 5V?



	Voltage [V]
CON101 2 nd pin ~ 3 rd pin	Not 0V, 5V

Yes
Change the Display PCB

4
Check the voltage.
Is CON101 1st pin ~ 3rd pin
voltage 0V or 5V?



	Voltage [V]
CON101 1 st pin ~ 3 rd pin	Not 0V, 5V

Yes
Change the Main PCB

5
Check the voltage.
Is CON5 4th pin ~ 6th pin
voltage 0V or 5V?

	Voltage [V]
CON5 4 th pin ~ 6 th pin	Not 0V, 5V

Yes
Change the Display PCB

6
Check the voltage.
Is CON5 4th pin ~ 8th pin
voltage 0V or 5V?

	Voltage [V]
CON5 4 th pin ~ 8 th pin	Not 0V, 5V

Yes
Change the Main PCB

7
Explain to customer

8-13. Cube mode doesn't work

Symptom	Check Point
1. Cube mode doesn't work	1. Check the loose connection 2. Check the resistance

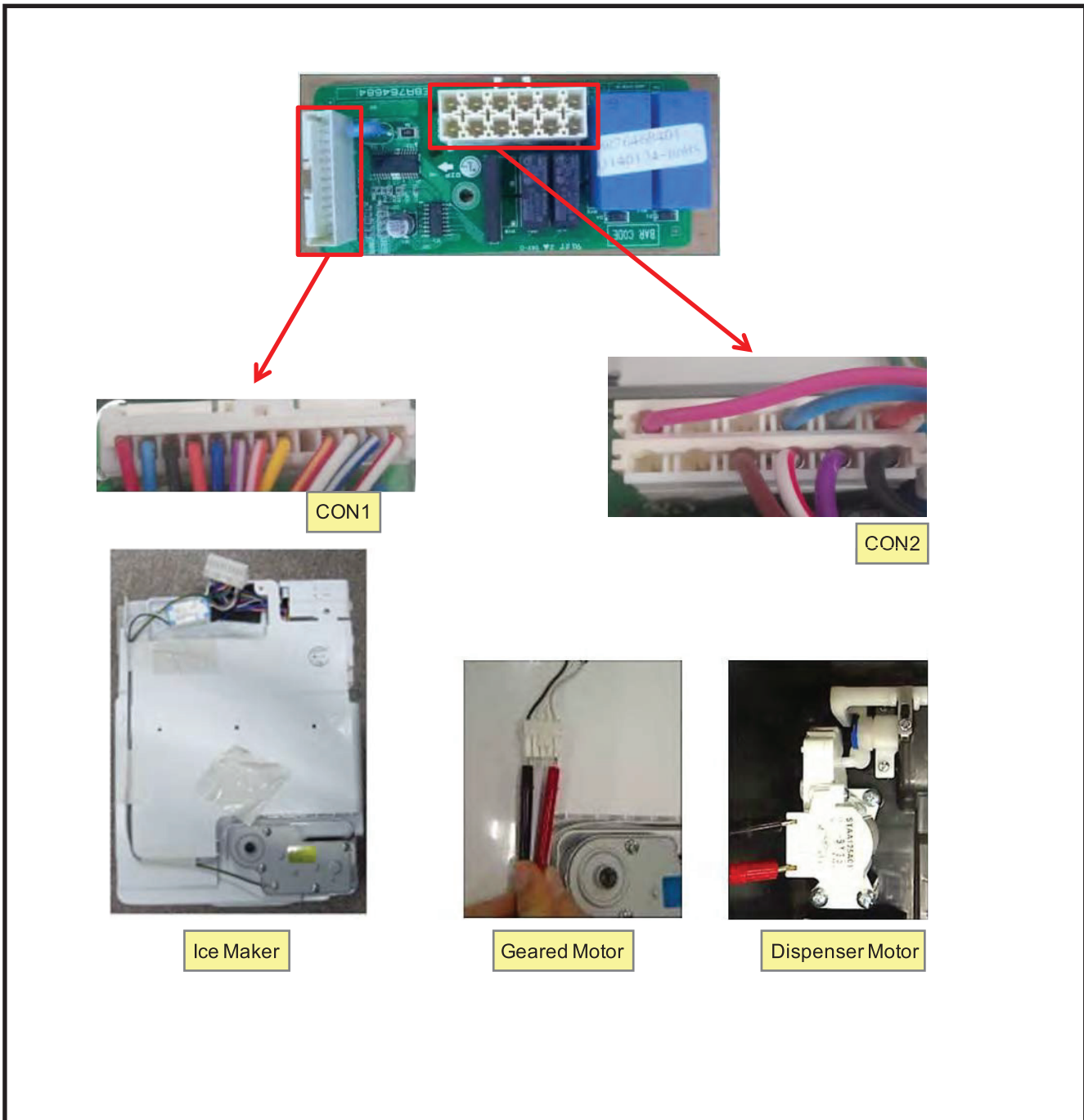

8-13. Cube mode doesn't work

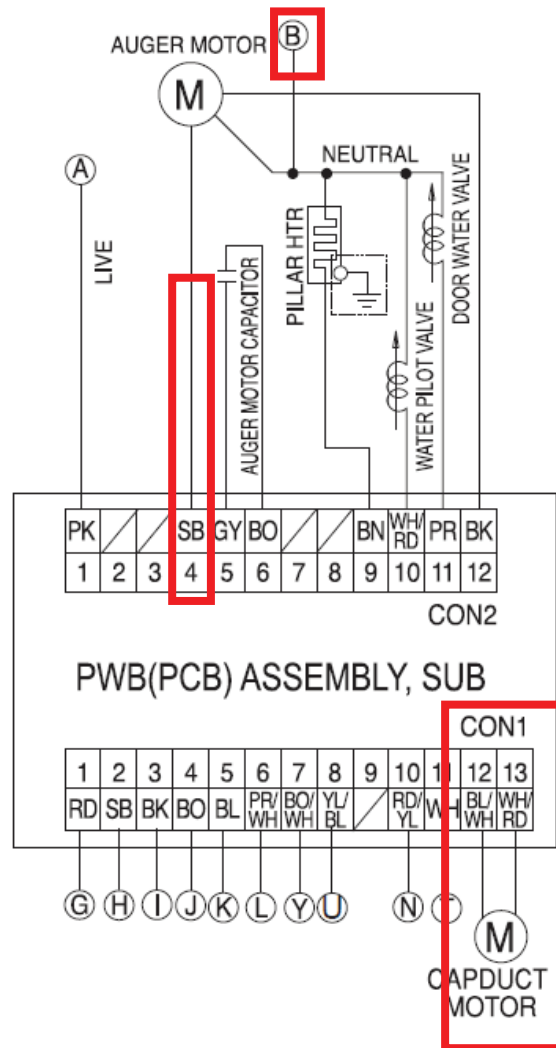

LEVER S/W	Voltage [V]	
CON2 4 th pin ~ B(NEUTRAL)	Pushing	112~115V
	Not Pushing	0~2V
CON1 12 th pin ~ 13 th pin	Pushing	9~12V
	Not Pushing	0~2V

	Resistance [Ω]
Geared Motor	18~40 Ω
Dispenser Motor	8~13 Ω

Cube mode doesn't work

1
Check the loose connection

2
Check the voltage.
(while pushing the lever S/W)
Is voltage correct?

No → Change the PCB



LEVER S/W	Voltage [V]	
CON2 4 th pin ~ B(NEUTRAL)	Pushing	112~115V
	Not Pushing	0~2V

Yes →

3
Check the voltage.
(while pushing the lever S/W)
Is voltage correct compared with table?

No → Change the PCB

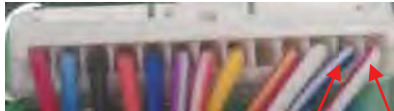

LEVER S/W	Voltage [V]	
CON1 12 th pin ~ 13 th pin	Pushing	9~ 12V
	Not Pushing	0~2V

Yes →

4
Check the resistance value.
Is Geared Motor resistance
31.1 ~ 42.1Ω?

No → Replace Geared Motor



	Resistance [Ω]
Geared Motor	18~40Ω

Yes →

5
Check the resistance value.
Is Dispenser Motor resistance
9.9 ~ 12.1Ω?

No → Replace Geared Motor

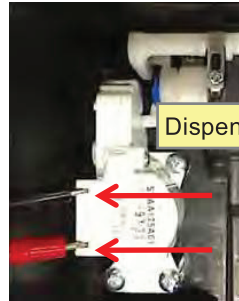

	Resistance [Ω]
Dispenser Motor	8~13Ω

Yes →

6
Explain to customer

8-14. Crush mode doesn't work

Symptom	Check Point
1. Crush mode doesn't work	1. Check the loose connection 2. Check the resistance

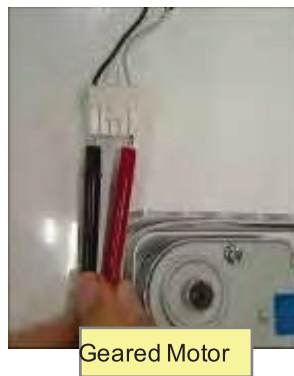
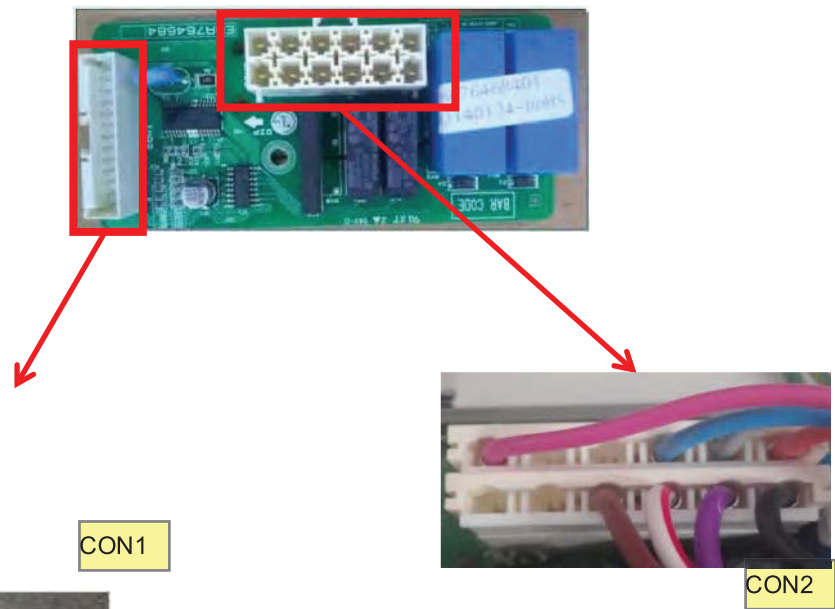

8-14. Crush mode doesn't work

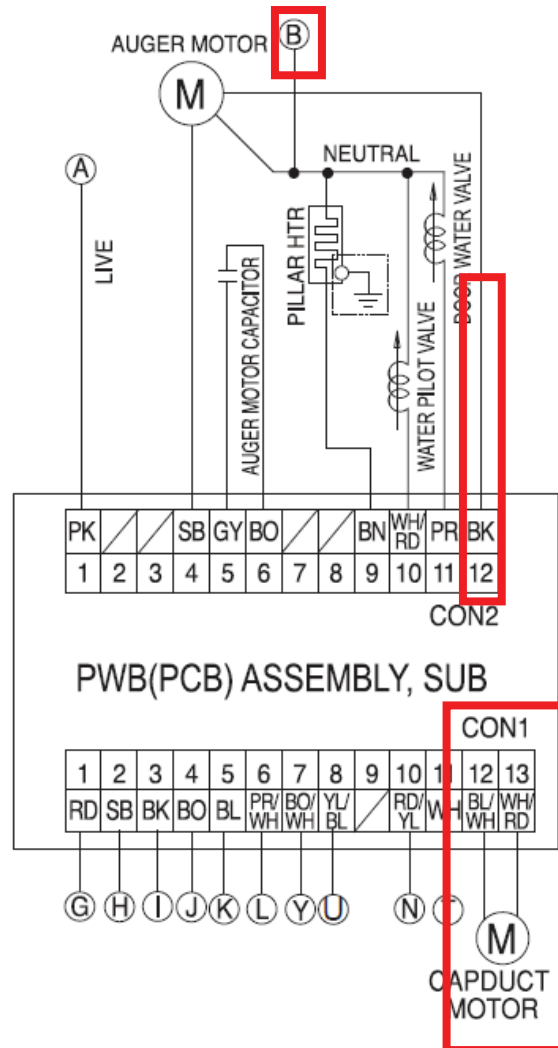

LEVER S/W	Voltage [V]	
CON2 12 th pin ~ B(NEUTRAL)	Pushing	112~115V
	Not Pushing	0~2V
CON1 12 th pin ~ 13 th pin	Pushing	9~12V
	Not Pushing	0~2V

	Resistance [Ω]
Geared Motor	18~40Ω
Dispenser Motor	8~13Ω

Cube mode doesn't work

1
Check the loose connection

2
Check the voltage.
(while pushing the lever S/W)
Is voltage correct?

No → Change the PCB

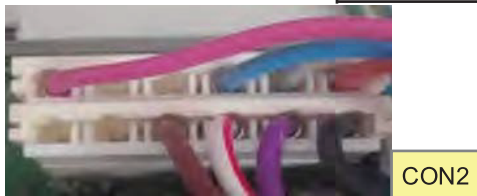

LEVER S/W	Voltage [V]	
CON2 12 th pin ~ B(NEUTRAL)	Pushing	112~115V
	Not Pushing	0~2V

Yes

3
Check the voltage.
(while pushing the lever S/W)
Is voltage correct compared with
table?

No → Change the PCB



LEVER S/W	Voltage [V]	
CON1 12 th pin ~ 13 th pin	Pushing	9~12V
	Not Pushing	0~2V

Yes

4
Check the resistance value.
Is Geared Motor resistance
31.1 ~ 42.1Ω?

No → Replace Geared Motor

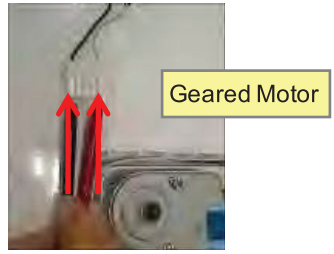

	Resistance [Ω]
Geared Motor	18~40Ω

Yes

5
Check the resistance value.
Is Dispenser Motor resistance
9.9 ~ 12.1Ω?

No → Replace Geared Motor

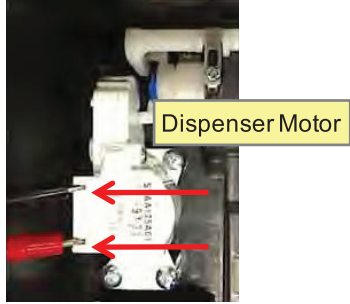

	Resistance [Ω]
Dispenser Motor	8~13Ω

Yes

6
Explain to customer

8-15. Water mode doesn't work

Symptom	Check Point
1. Water mode doesn't work	1. Check the loose connection 2. Check the resistance valve

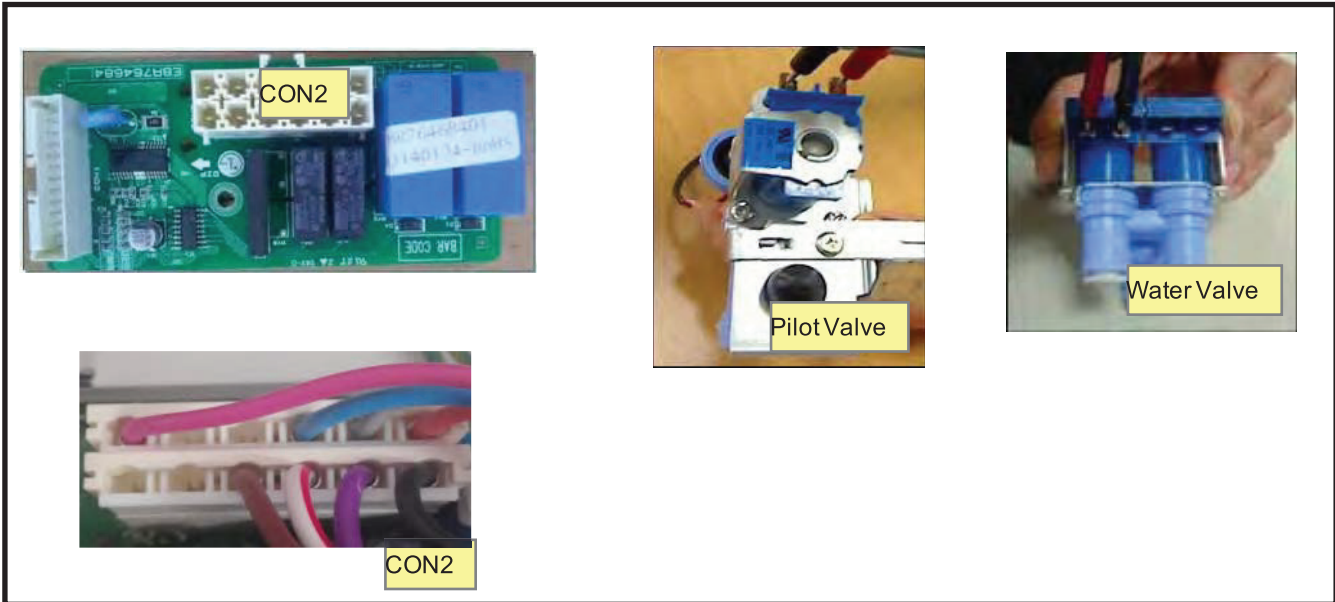

PWB(PCB) ASSEMBLY, SUB

CON1

1	2	3	4	5	6	7	8	9	10	11	12	13
RD	SB	BK	BO	BL	PR/WH	BO/WH	YL/BL	RD/BL	WH/WH	BL/WH	WH/WH	RD
G	H	I	J	K	L	Y	U	N	T	M		

CAPDUCT MOTOR

LEVER S/W	Voltage [V]	
CON2 11 th pin ~ B(NEUTRAL)	Pushing	112~115V
	Not Pushing	0~2V
CON2 10 th pin ~ B(NEUTRAL)	Pushing	9~12V
	Not Pushing	0~2V

	Resistance [Ω]
Pilot Valve	360 ~ 440
Water valve	360 ~ 440

Water mode doesn't work

1
Check the loose connection

2
Check the voltage.
(while pushing the lever S/W)
Is voltage correct?



CON2

LEVER S/W	Voltage [V]	
	Pushing	Not Pushing
CON2 11 th pin ~ B(NEUTRAL)	Pushing	112~115V
	Not Pushing	0~2V
CON2 10 th pin ~ B(NEUTRAL)	Pushing	9~12V
	Not Pushing	0~2V

No
Change the PCB

Yes

3
Check the resistance value.
Is Pilot Valve resistance
360~420Ω?

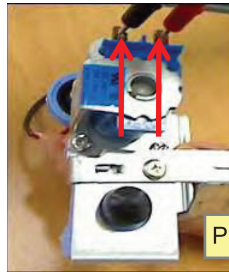

Pilot Valve

	Resistance [Ω]
Pilot Valve	360 ~ 440

No
Replace P/ Valve

Yes

4
Check the resistance value.
Is Water Valve resistance
360~420Ω?

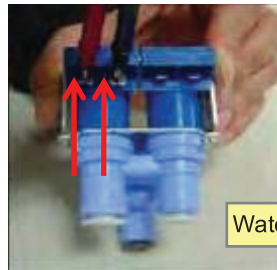

Water Valve

	Resistance [Ω]
Water valve	360 ~ 440

No
Replace Water Valve

Yes

5
Explain to customer

8-16. Middle room lamp doesn't work

Symptom	Check Point
1. Middle room lamp doesn't work	1. Check the freezer door switch sticky 2. Check the door S/W resistance 3. Check the LED Lamp

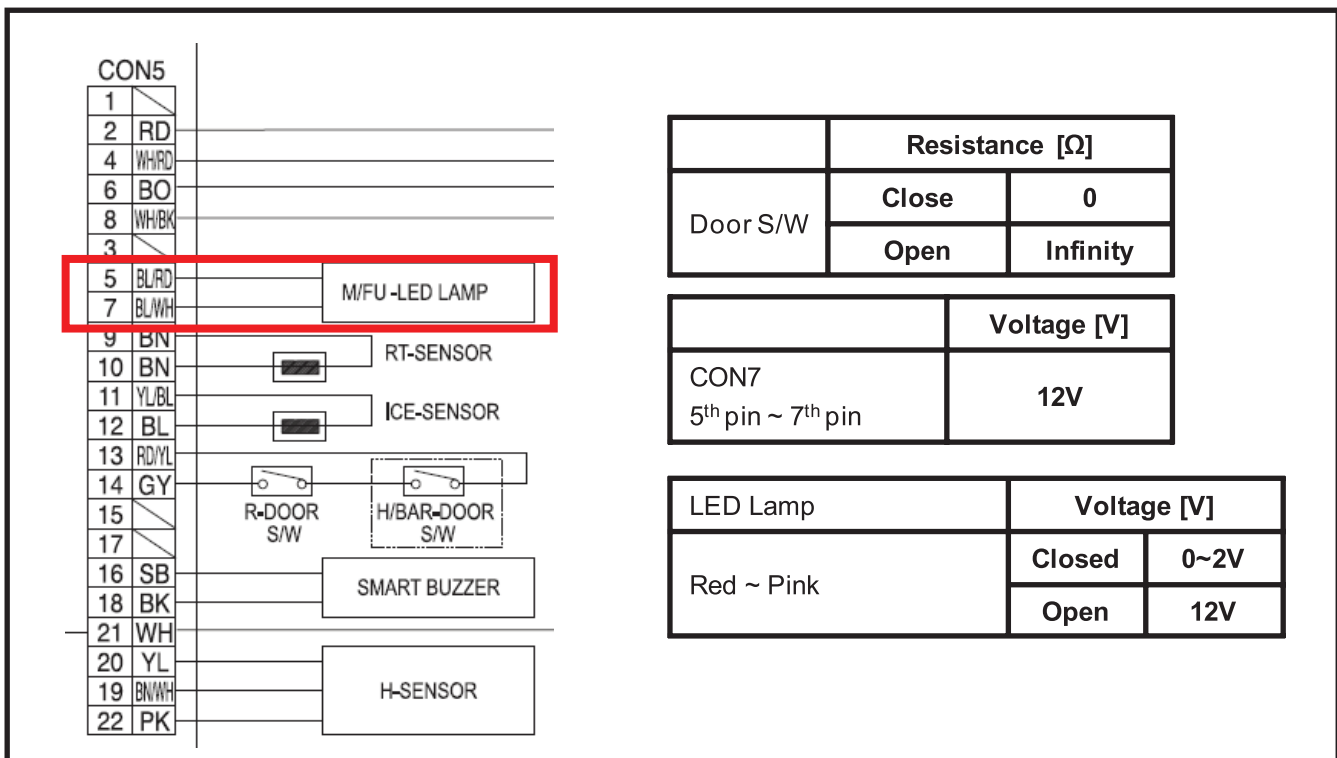
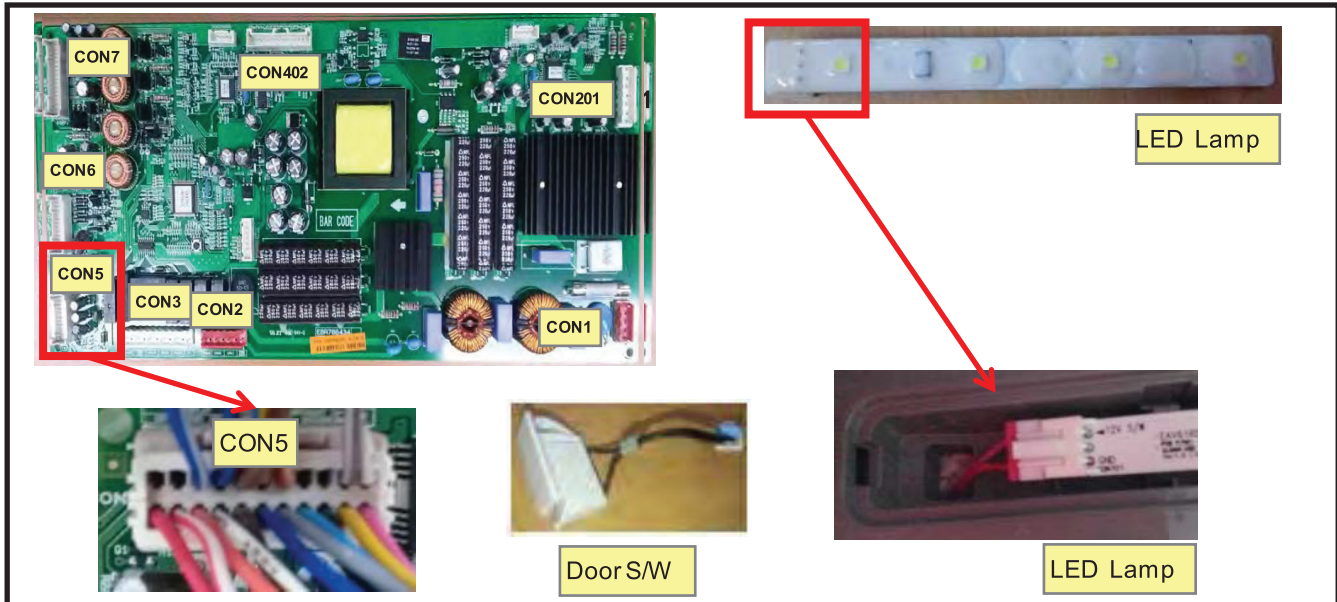

Middle room lamp doesn't work

1
Check the Freezer door switch. Does it feel sticky?

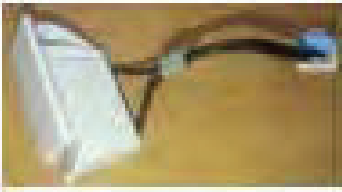

Yes → Change the Door S/W

No → [Proceed to Step 2]

2
Check the door S/W resistance. Is it correct compared with table?



Door S/W

Resistance [Ω]		
Door S/W	Close	0
	Open	Infinity

No → Change the Door S/W

Yes → [Proceed to Step 3]

3
Check the PCB Voltage. Is CON 5th pin ~ 7th pin voltage 12V?

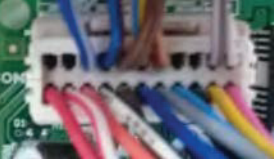

CON5

Voltage [V]	
CON7 5 th pin ~ 7 th pin	12V

No → Change the PCB

Yes → [Proceed to Step 4]

4
Check the LED Lamp voltage. Is voltage 12V? (While door open)

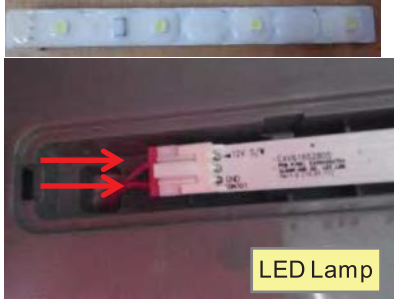

LED Lamp

No → Change the LED Lamp

Yes → [Proceed to Step 5]

5
Check the LED Lamp voltage. Is it 0~2V? (While door closed)

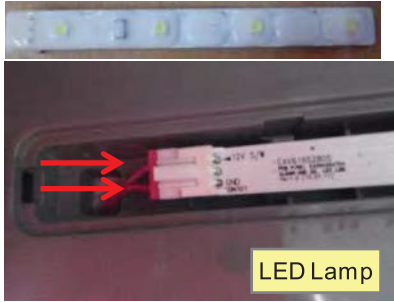

LED Lamp

No → Change the Door S/W

Yes → [Proceed to Step 6]

6
Check the LED Lamp voltage. Is it 12V? (While door open)

No → Change the LED Lamp

Yes → [Proceed to Step 7]

7
Explain to customer

8-17. Freezer room lamp doesn't work

Symptom	Check Point
1. Freezer room lamp doesn't work	1. Check the freezer door switch sticky 2. Check the door S/W resistance 3. Check the LED Lamp

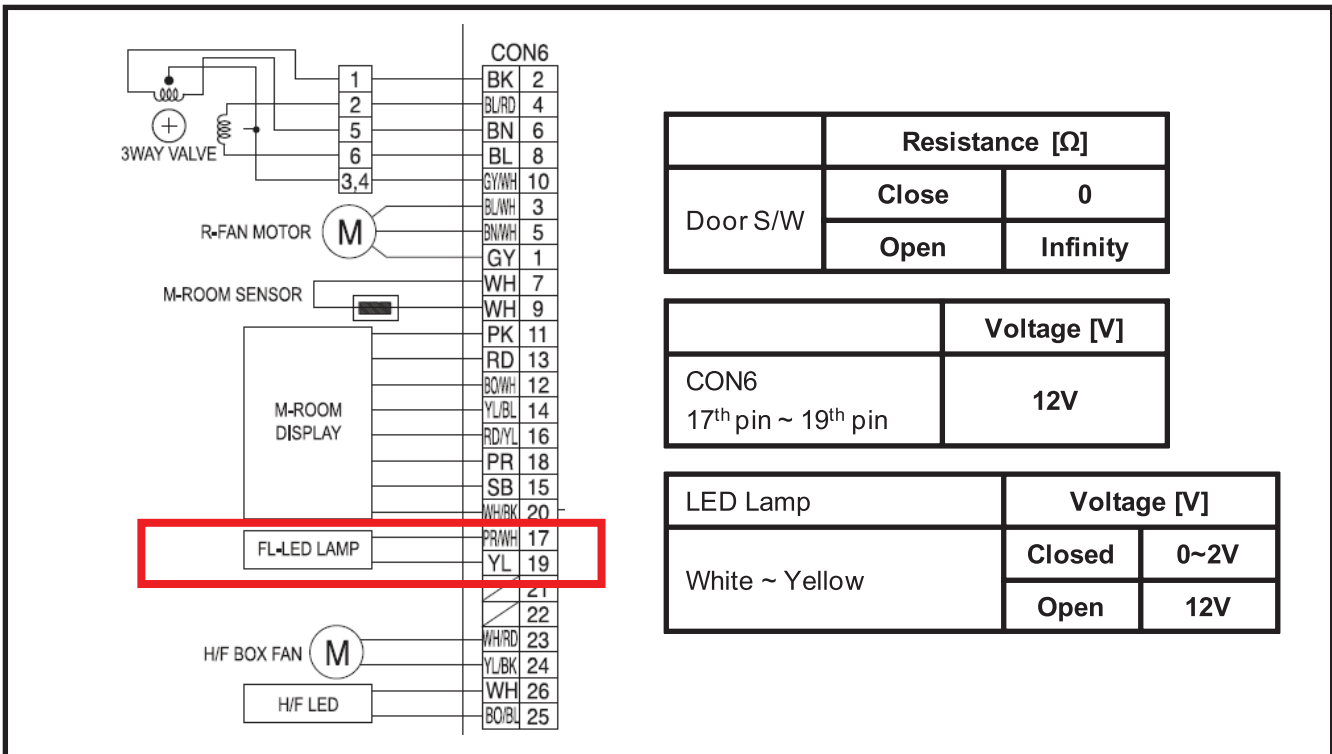
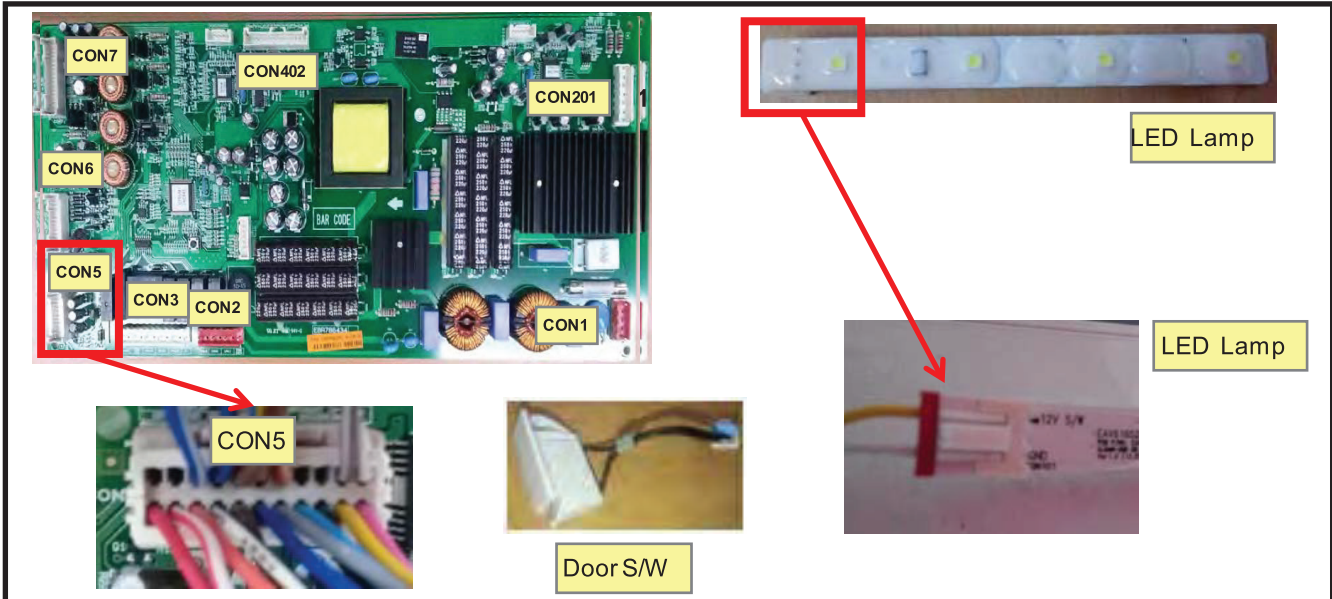

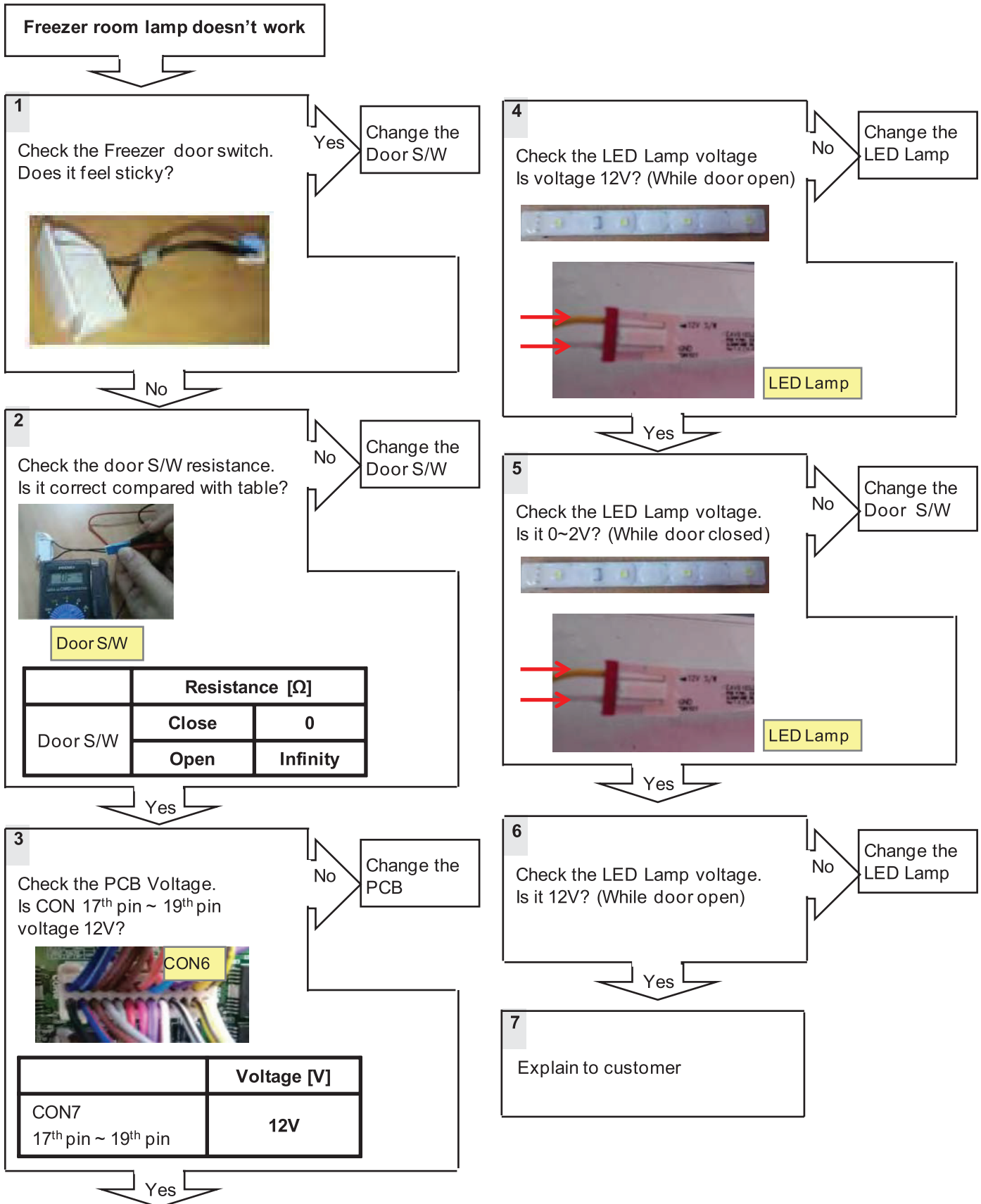

8-18. Refrigerator room lamp doesn't work

Symptom	Check Point
1. Refrigerator room lamp doesn't work	1. Check the Refrigerator door switch sticky 2. Check the door S/W resistance 3. Check the LED Lamp

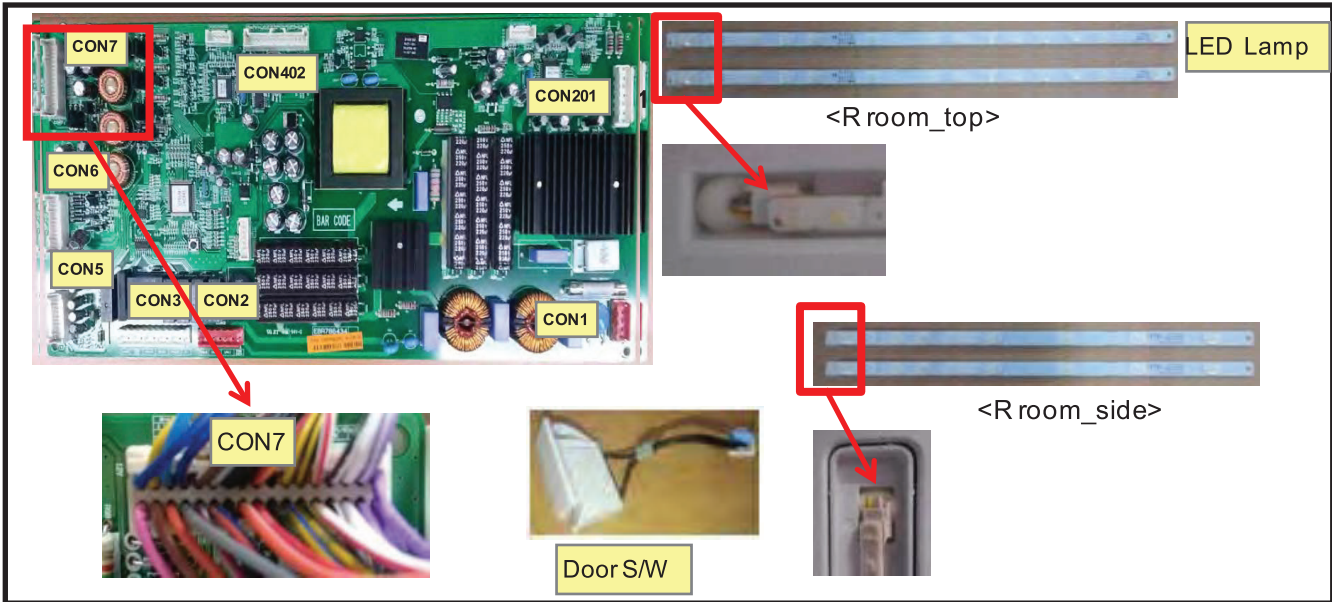

CON7 1 BL 3 YL 5 SB 7 BL/PD 2 GY 4 BN 6 BO 8 PK 11 GY/W 13 BK 9 BW/W 12 BO/BL 14 BK 15 BK 17 RD/YL 18 RD 20 BK 16 BW/W 21 WH/BK 22 WH/BK 23 PR/W 24 PR/W 25 WH/R 26 WH/R 19 27 YL/BL 28 YL/BL 29 WH 30 WH 31 YL/BK 32 YL/BK 33 PR 34 PR	M R-ROOM STEPPING MOTOR M M-ROOM STEPPING MOTOR M ICING-FAN MOTOR M C-FAN MOTOR R-ROOM LED MODULE M F-FAN MOTOR RD-SENSOR R-SENSOR F-SENSOR FD1-SENSOR MFU-DOOR S/W FL-DOOR S/W BETA DUCT HTR
--	---

Door S/W	Resistance [Ω]	
	Normal	0
Push S/W	Infinity	

Voltage [V]	
CON7 15 th pin ~ 17 th pin	12V

LED Lamp	Voltage [V]	
	Yellow~ White	Closed
Open		12V

Refrigerator room lamp doesn't work

1
Check the Refrigerator door switch.
Does it feel sticky?

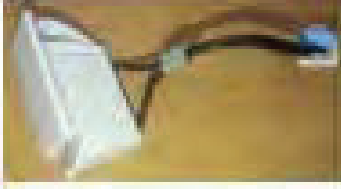

Yes → Change the Door S/W

No →

2
Check the door S/W resistance.
Is it correct compared with table?



Door S/W

Resistance [Ω]		
Door S/W	Close	0
	Open	Infinity

No → Change the Door S/W

Yes →

3
Check the PCB Voltage.
Is CON 15th pin ~ 17th pin voltage 12V?

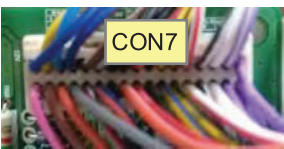



CON7

Voltage [V]	
CON7 15 th pin ~ 17 th pin	12V



No → Change the PCB

Yes →

4
Check the LED Lamp voltage.
Is voltage 12V? (While door open)

<R room_top>



<R room_side>

LED Lamp



No → Change the LED Lamp

Yes →

5
Check the LED Lamp voltage.
Is it 0~2V? (While door closed)

<R room_top>

<R room_side>

LED Lamp

No → Change the Door S/W

Yes →

6
Check the LED Lamp voltage.
Is it 12V? (While door open)

No → Change the LED Lamp

Yes →

7
Explain to customer

8-19. Poor cooling in Fresh food section

Symptom	Check Point
1. Poor cooling in Fresh food section	1. Check the sensor resistance 2. Check the air flow 3. Check the air Temperature 4. Check the R-Fan motor voltage

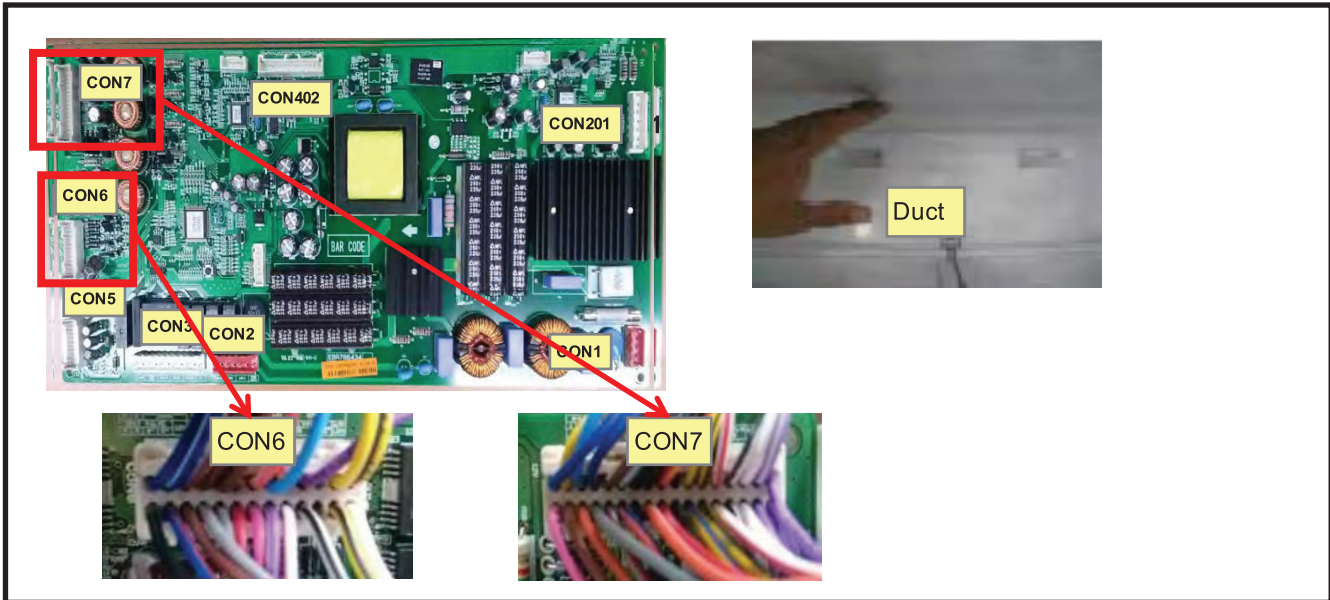

<table border="1"> <thead> <tr> <th>CON7</th> <th>Component</th> </tr> </thead> <tbody> <tr><td>1 BL</td><td></td></tr> <tr><td>3 YL</td><td></td></tr> <tr><td>5 SB</td><td></td></tr> <tr><td>7 BLRD</td><td></td></tr> <tr><td>2 GY</td><td></td></tr> <tr><td>4 BN</td><td></td></tr> <tr><td>6 BO</td><td></td></tr> <tr><td>8 PK</td><td></td></tr> <tr><td>11 BW</td><td></td></tr> <tr><td>13 BK</td><td></td></tr> <tr><td>9 BW</td><td></td></tr> <tr><td>12 BORD</td><td></td></tr> <tr><td>14 BK</td><td></td></tr> <tr><td>10 GRD</td><td></td></tr> <tr><td>15 BK</td><td></td></tr> <tr><td>17 RDYL</td><td></td></tr> <tr><td>18 RD</td><td></td></tr> <tr><td>20 BK</td><td></td></tr> <tr><td>16 BOWH</td><td></td></tr> <tr><td>21 WH</td><td></td></tr> <tr><td>22 BK</td><td></td></tr> <tr><td>23 PW</td><td>R-SENSOR</td></tr> <tr><td>24 PW</td><td>R-SENSOR</td></tr> <tr><td>26 BK</td><td></td></tr> <tr><td>19</td><td></td></tr> <tr><td>27 VL</td><td></td></tr> <tr><td>28 VL</td><td></td></tr> <tr><td>29 WH</td><td></td></tr> <tr><td>30 WH</td><td></td></tr> <tr><td>31 VL</td><td></td></tr> <tr><td>32 VL</td><td></td></tr> <tr><td>33 PR</td><td></td></tr> <tr><td>34 PR</td><td></td></tr> </tbody> </table>	CON7	Component	1 BL		3 YL		5 SB		7 BLRD		2 GY		4 BN		6 BO		8 PK		11 BW		13 BK		9 BW		12 BORD		14 BK		10 GRD		15 BK		17 RDYL		18 RD		20 BK		16 BOWH		21 WH		22 BK		23 PW	R-SENSOR	24 PW	R-SENSOR	26 BK		19		27 VL		28 VL		29 WH		30 WH		31 VL		32 VL		33 PR		34 PR			<table border="1"> <thead> <tr> <th>CON7 23th pin ~ 24th pin</th> <th>Resistance [Ω]</th> </tr> </thead> <tbody> <tr> <td>23°F / -5°C</td> <td>38k</td> </tr> <tr> <td>32°F / 0°C</td> <td>30k</td> </tr> <tr> <td>41°F / 5°C</td> <td>24k</td> </tr> <tr> <td>50°F / 10°C</td> <td>19.5k</td> </tr> <tr> <td>59°F / 15°C</td> <td>16k</td> </tr> </tbody> </table>	CON7 23 th pin ~ 24 th pin	Resistance [Ω]	23°F / -5°C	38k	32°F / 0°C	30k	41°F / 5°C	24k	50°F / 10°C	19.5k	59°F / 15°C	16k
CON7	Component																																																																																	
1 BL																																																																																		
3 YL																																																																																		
5 SB																																																																																		
7 BLRD																																																																																		
2 GY																																																																																		
4 BN																																																																																		
6 BO																																																																																		
8 PK																																																																																		
11 BW																																																																																		
13 BK																																																																																		
9 BW																																																																																		
12 BORD																																																																																		
14 BK																																																																																		
10 GRD																																																																																		
15 BK																																																																																		
17 RDYL																																																																																		
18 RD																																																																																		
20 BK																																																																																		
16 BOWH																																																																																		
21 WH																																																																																		
22 BK																																																																																		
23 PW	R-SENSOR																																																																																	
24 PW	R-SENSOR																																																																																	
26 BK																																																																																		
19																																																																																		
27 VL																																																																																		
28 VL																																																																																		
29 WH																																																																																		
30 WH																																																																																		
31 VL																																																																																		
32 VL																																																																																		
33 PR																																																																																		
34 PR																																																																																		
CON7 23 th pin ~ 24 th pin	Resistance [Ω]																																																																																	
23°F / -5°C	38k																																																																																	
32°F / 0°C	30k																																																																																	
41°F / 5°C	24k																																																																																	
50°F / 10°C	19.5k																																																																																	
59°F / 15°C	16k																																																																																	
		<table border="1"> <thead> <tr> <th>TEST MODE 1</th> <th>Voltage [V]</th> </tr> </thead> <tbody> <tr> <td>CON6 3rd pin ~ 5th pin</td> <td>8~14V</td> </tr> <tr> <td>CON6 1st pin ~ 5th pin</td> <td>Not 0V, 5V</td> </tr> </tbody> </table>	TEST MODE 1	Voltage [V]	CON6 3 rd pin ~ 5 th pin	8~14V	CON6 1 st pin ~ 5 th pin	Not 0V, 5V																																																																										
TEST MODE 1	Voltage [V]																																																																																	
CON6 3 rd pin ~ 5 th pin	8~14V																																																																																	
CON6 1 st pin ~ 5 th pin	Not 0V, 5V																																																																																	
<table border="1"> <tbody> <tr> <td>Duct</td> <td>Status</td> </tr> <tr> <td>Air Flow</td> <td>Windy</td> </tr> <tr> <td>Air Temperature</td> <td>Cold</td> </tr> </tbody> </table>	Duct	Status	Air Flow	Windy	Air Temperature	Cold																																																																												
Duct	Status																																																																																	
Air Flow	Windy																																																																																	
Air Temperature	Cold																																																																																	

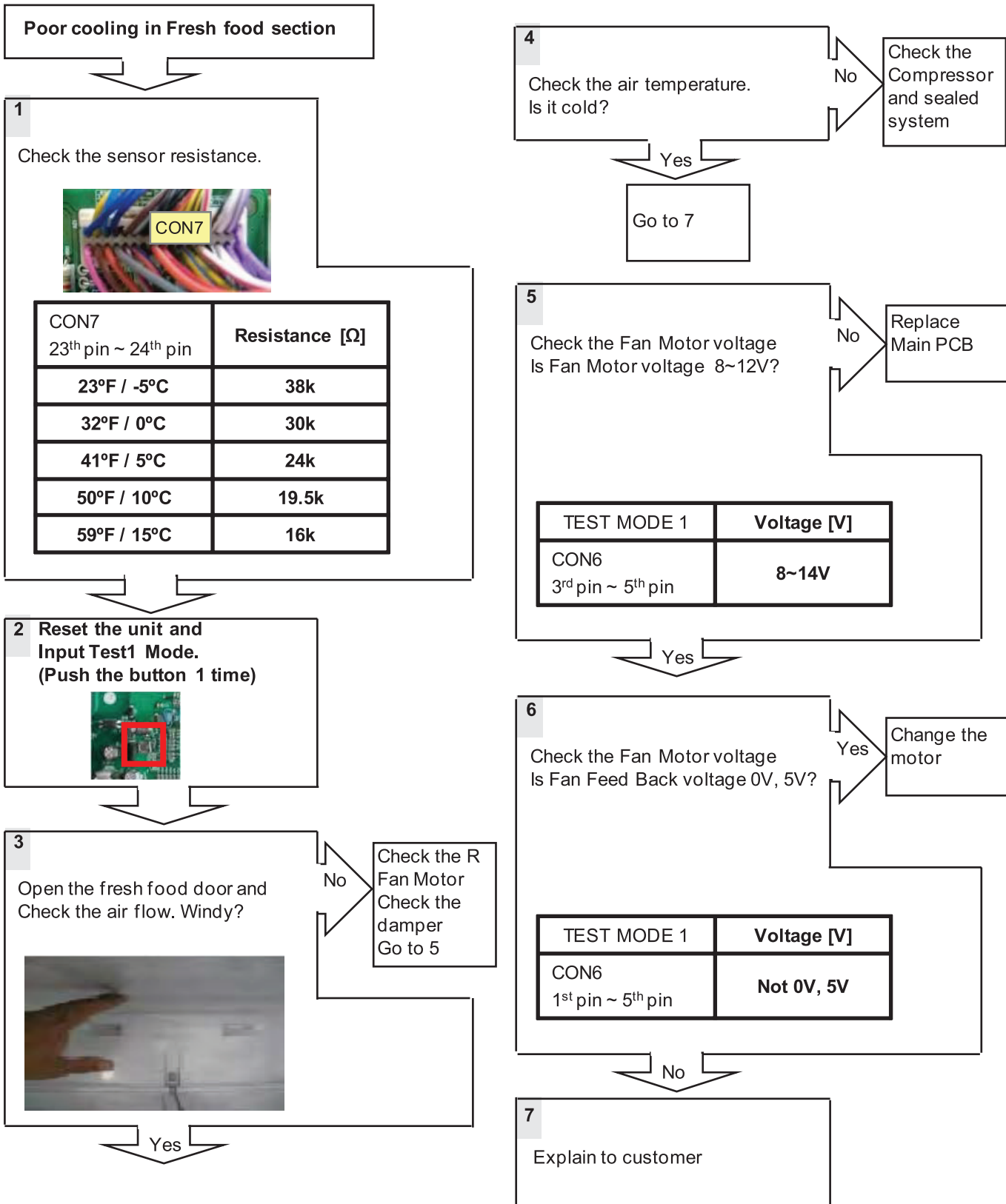

8-20. Poor cooling in Freezer compartment

Symptom	Check Point
1. Poor cooling in Freezer compartment	1. Check the sensor resistance 2. Check the air flow 3. Check the air Temperature 4. Check the Fan motor sticky 4. Check the Fan motor voltage

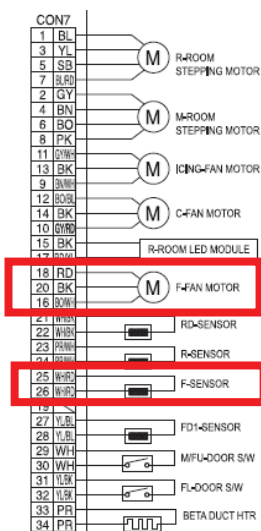
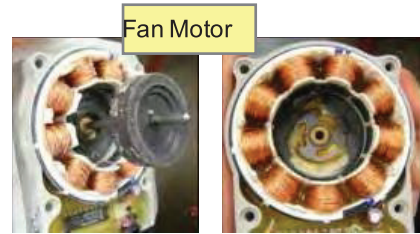
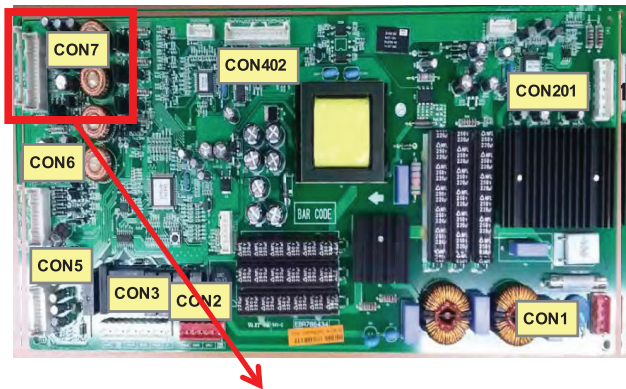

CON7 25 th pin ~ 26 th pin	Resistance [Ω]
-22°F / -30°C	40k
-13°F / -25°C	30k
-4°F / -20°C	23k
-13°F / -25°C	17k
14°F / -10°C	13k
23°F / -5°C	10k
32°F / 0°C	8k

TEST MODE 1	Voltage [V]
CON7 18 th pin ~ 20 th pin	8~14V
CON7 16 th pin ~ 20 th pin	Not 0V, 5V

Duct	Status
Air Flow	Windy
Air Temperature	Cold

Poor cooling in Freezer compartment

1
Check the sensor resistance.

CON7 25 th pin ~ 26 th pin	Resistance [Ω]
-22°F / -30°C	40k
-13°F / -25°C	30k
-4°F / -20°C	23k
-13°F / -25°C	17k
14°F / -10°C	13k
23°F / -5°C	10k
32°F / 0°C	8k

2 Reset the unit and Input Test1 Mode.
(Push the button 1 time)



3
Open the fresh food door and Check the air flow. Windy?



No
Check the F Fan Motor
Go to 5

4
Check the air temperature.
Is it cold?

No
Check the Compressor and sealed system

5
Check the Fan motor.
Rotate fan using hand.
It feel sticky?

Yes
Change the Fan motor

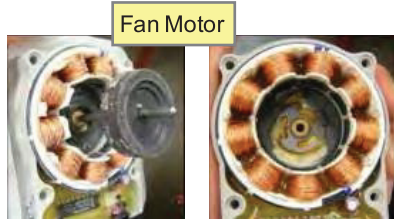

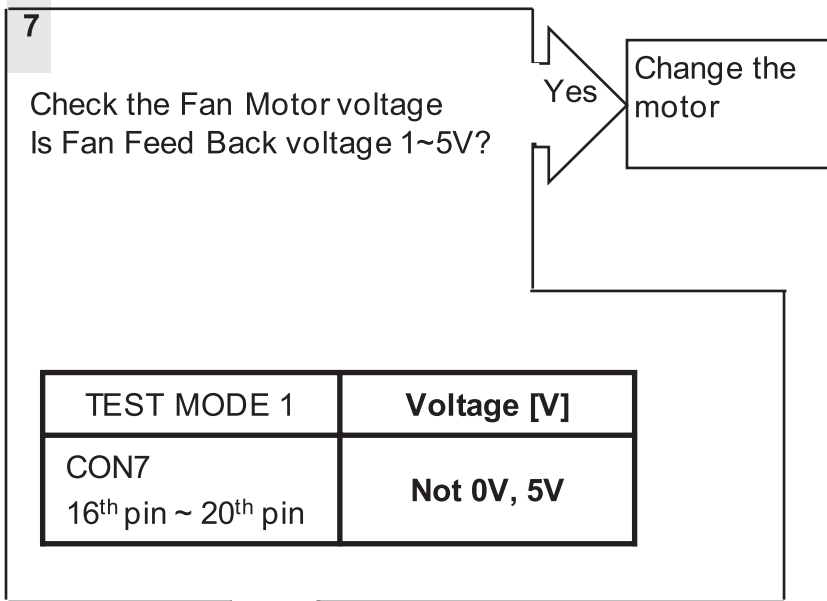
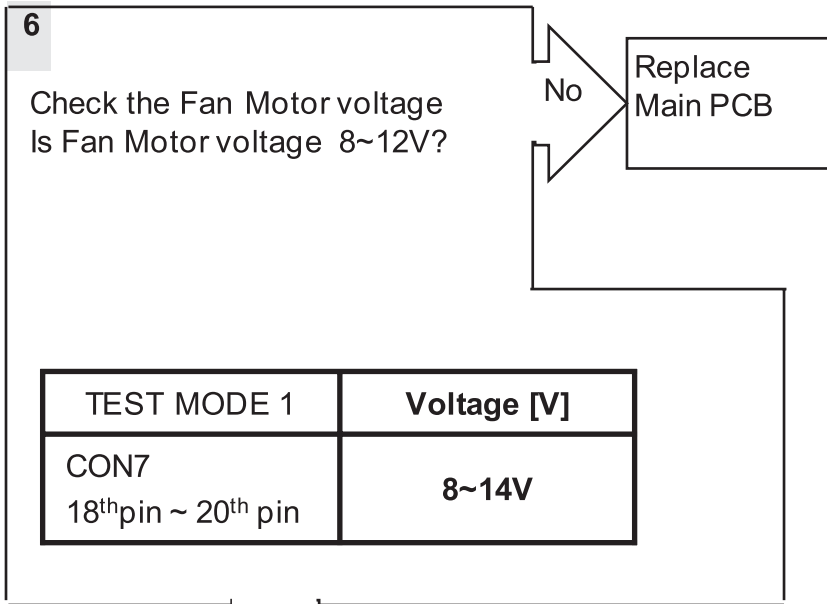

8

Explain to customer

10. Reference

10-1 TEST MODE and Removing TPA

1. How to make TEST MODE

If you push the test button on the Main PCB, the refrigerator will enter the TEST MODE.



Main PCB

* 1 time : Comp / Damper / All FAN on
(All things displayed)

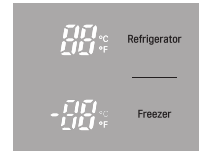

* 2 times : Damper closed
(22 22 displayed)



* 3 times : Forced defrost mode
(33 33 displayed)



2. How to remove Terminal Position Assurance (TPA)

<AC TPA>



<DC TPA>



※ After measure the values, you should put in the TPA again.

10-2 TEMPERATRUE CHART - FREEZER AND ICING SENSOR

TEMP	RESISTANCE	VOLTAGE
-39°F (-40°C)	73.29 kΩ	4.09 V
-30°F (-35°C)	53.63 kΩ	3.84 V
-30°F (-21°C)	39.66 kΩ	3.55 V
-13°F (-25°C)	29.62 kΩ	3.23 V
-4°F (-20°C)	22.33 kΩ	2.89 V
5°F (-15°C)	16.99 kΩ	2.56 V
14°F (-10°C)	13.05 kΩ	2.23 V
23°F (-5°C)	10.10 kΩ	1.92 V
32°F (0°C)	7.88 kΩ	1.63 V
41°F (+5°C)	6.19 kΩ	1.38 V
50°F (+10°C)	4.91 kΩ	1.16 V
59°F (+15°C)	3.91 kΩ	0.97 V
68°F (+20°C)	3.14 kΩ	0.81 V
77°F (+25°C)	2.54 kΩ	0.67 V
86°F (+30°C)	2.07 kΩ	0.56 V
95°F (+35°C)	1.69 kΩ	0.47 V
104°F (+40°C)	1.39 kΩ	0.39 V

10-3 TEMPERATRUE CHART - REFRIGERATOR AND DEFROST SENSOR

TEMP	RESISTANCE	VOLTAGE
-39°F (-40°C)	225.1 kΩ	4.48 V
-30°F (-35°C)	169.8 kΩ	4.33 V
-30°F (-21°C)	129.3 kΩ	4.16 V
-13°F (-25°C)	99.30 kΩ	3.95 V
-4°F (-20°C)	76.96 kΩ	3.734 V
5°F (-15°C)	60.13 kΩ	3.487 V
14°F (-10°C)	47.34 kΩ	3.22 V
23°F (-5°C)	37.55 kΩ	2.95 V
32°F (0°C)	30 kΩ	2.67 V
41°F (+5°C)	24.13 kΩ	2.40 V
50°F (+10°C)	19.53 kΩ	2.14 V
59°F (+15°C)	15.91 kΩ	1.89 V
68°F (+20°C)	13.03 kΩ	1.64 V
77°F (+25°C)	10.74 kΩ	1.45 V
86°F (+30°C)	8.89 kΩ	1.27 V
95°F (+35°C)	7.40 kΩ	1.10 V
104°F (+40°C)	6.20 kΩ	0.96 V

10-4 How to check the Fan-Error

After sending a signal to the fan, the MICOM checks the BLDC fan motor's lock status. If there is no feedback signal from the BLDC fan, the fan motor stops for 10 seconds and then is powered again for 15 seconds. To determine that there is a fan motor malfunction, this process is repeated 3 times. If the fan motor is determined to be defective, the error code will be shown in the display for 30 minutes. At this point, the process will be repeated until the fan motor operates normally. If normal operation is achieved, the error display is erased and the MICOM is reset automatically.

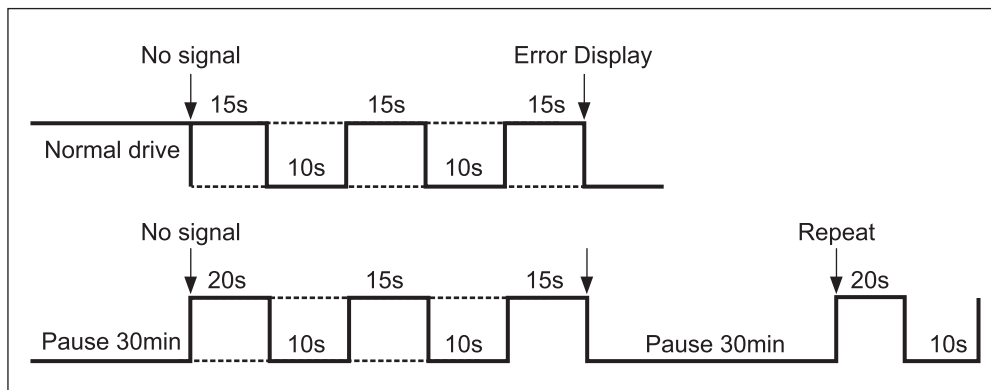

11. COMPONENT TESTING INFORMATION

11-1 Defrost Sensor of Defrost heater (F/R)

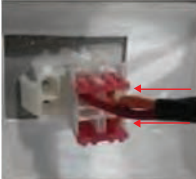
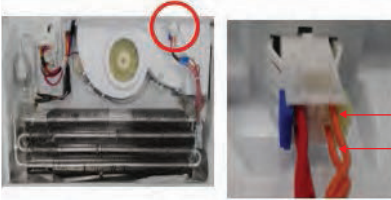
<p>Function</p>	<p>The Defrost heater is made up of two kinds of parts. The defrost sensor and heater. To determine if the sensor is defective, check the resistance.</p>					
<p>How to Measure (Sensor)</p>	  <p>Defrost Sensor</p>	<p>Set a ohmmeter to The 2housing pin. Measure the 2 pin connected to Sensor. If the ohmmeter indicate 11 kΩ (at room temperature) Sensor is good. When check the ohm at other temperatures Check the sensor manual.</p>  <p>Defrost Sensor</p>				
<p>Standard</p>	<p>Sensor (at room temperature)</p> <table border="1" data-bbox="386 1053 820 1144"> <thead> <tr> <th>Test Point</th> <th>Ressult</th> </tr> </thead> <tbody> <tr> <td>(1) to (2)</td> <td>11kΩ</td> </tr> </tbody> </table>		Test Point	Ressult	(1) to (2)	11kΩ
Test Point	Ressult					
(1) to (2)	11kΩ					

11-2 Sheath Heater (Freezer Room)

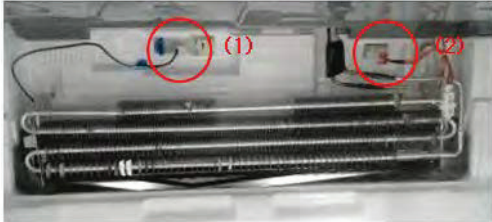
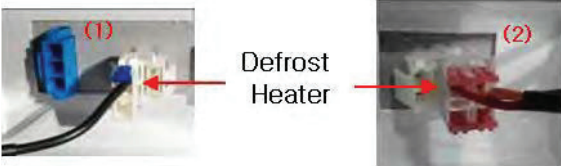
Function	<p>Sheath heater is made up of Fuse and heater. To determine if these parts are defective, check the resistance. The fuse will cut power to the defrost heater at very high temperatures.</p>				
How to Measure	<div style="text-align: center;">  </div> <div style="text-align: center; margin-top: 20px;">  </div> <p>Set a ohmmeter connect to The housing pins. Measure the pins connected to Sheath Heater. If the ohmmeter indicates $(V^{\circ}\phi V)/Watt=R$ is on a good condition, ex) watt=350W, voltage=115V $R=(115^{\circ}\phi 115)/350=38 \Omega$ Infinitive value implies Fuse is cut off.</p>				
Standard	<p style="text-align: center;">Sheath heater (at all temperature)</p> <table border="1" style="margin-left: auto; margin-right: auto;"> <thead> <tr> <th>Test Point</th> <th>Ressult</th> </tr> </thead> <tbody> <tr> <td>(1) to (2)</td> <td>38~42</td> </tr> </tbody> </table>	Test Point	Ressult	(1) to (2)	38~42
Test Point	Ressult				
(1) to (2)	38~42				

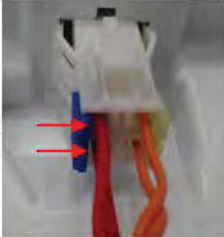

11-2 Sheath Heater (Refrigerator Room)

<p>Function</p>	<p>Sheath heater is made up of Fuse and heater. To determine if these parts are defective, check the resistance. The fuse will cut power to the defrost heater at very high temperatures.</p>				
<p>How to Measure</p>	<div style="display: flex; align-items: center;">  <div style="margin-left: 20px;">  <p style="margin-left: 10px;">Defrost heater</p> </div> </div> <p>Set a ohmmeter connect to The housing pins. Measure the pins connected to Sheath Heater. If the ohmmeter indicates $(V^{\circ}\phi V)/Watt=R$ is on a good condition, ex) watt=350W, voltage=115V $R=(115^{\circ}\phi 115)/350=38\Omega$ Infinite value implies Fuse is cut off.</p>				
<p>Standard</p>	<p>Sheath heater (at all temperature)</p> <table border="1" style="margin-left: 40px;"> <thead> <tr> <th>Test Point</th> <th>Result</th> </tr> </thead> <tbody> <tr> <td>(1) to (2)</td> <td>82.6~91.4</td> </tr> </tbody> </table>	Test Point	Result	(1) to (2)	82.6~91.4
Test Point	Result				
(1) to (2)	82.6~91.4				

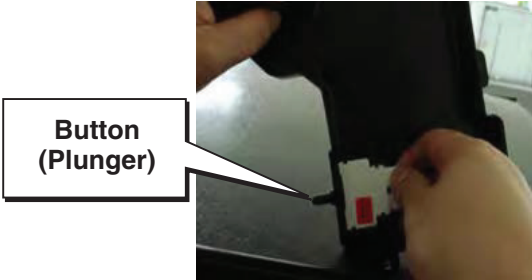
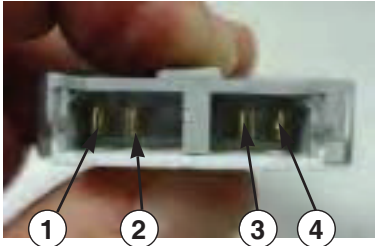
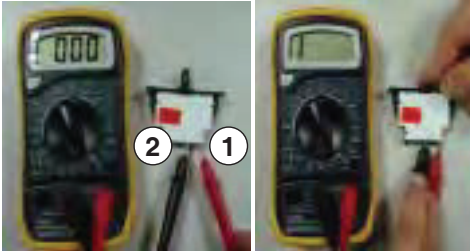
11-4 Door Switch,R

<p>Function</p>	<p>The switch senses if the door is open or closed.</p> <ul style="list-style-type: none"> - When the door open, lamp on. - When the door open, the switch give information to Micom. <p>When the door open, internal contact operate on and off moving plunger of door switch up and down.</p>				
<p>How to Measure</p>	<p style="text-align: center;"><Switch, Refrigerator></p> <div style="text-align: center;">  </div> <div style="text-align: center;">  </div> <div style="text-align: center;">  </div> <p style="text-align: center;">Beep</p> <p>Check the resistance between connectors 1, 2 .It means check whether or not applying an electric current. If there is resistance, the switch is good.</p>				
<p>Standard</p>	<p style="text-align: center;">Multimeter beep – Switch,R</p> <table border="1" style="margin-left: auto; margin-right: auto;"> <tr> <td style="padding: 5px;">Nomal</td> <td style="padding: 5px;">Push the button(Plunger)</td> </tr> <tr> <td style="padding: 5px;">Beep or 0 Ω</td> <td style="padding: 5px;">None (∞ Ω)</td> </tr> </table>	Nomal	Push the button(Plunger)	Beep or 0 Ω	None (∞ Ω)
Nomal	Push the button(Plunger)				
Beep or 0 Ω	None (∞ Ω)				

11-5 Door Switch,F

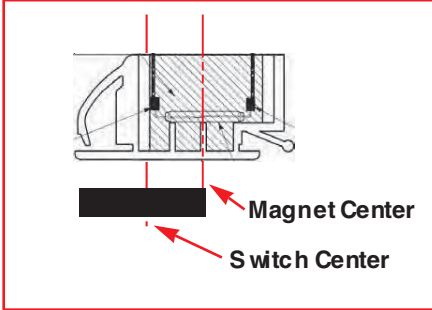
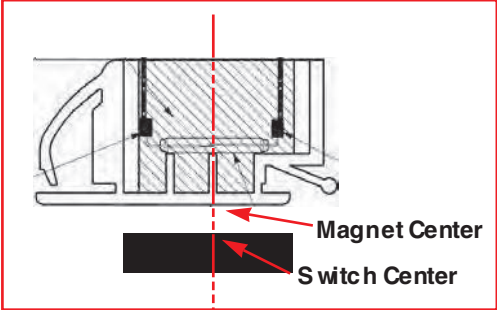
<p>Function</p>	<p>The switch senses if the door is open or closed. - When the door open, lamp on. - When the door open, the switch give information to Micom. When the door open, internal contact operate on and off moving plunger of door switch up and down.</p>																		
<p>How to Measure</p>	<div style="display: flex; justify-content: space-around;"> <div style="text-align: center;"> <p>No magnet</p>  </div> <div style="text-align: center;"> <p>Magnet near the Switch</p>  </div> </div> <p style="text-align: center;">* Magnet must be center of Switch</p> <div style="display: flex; justify-content: space-around;"> <div style="text-align: center;">  <p>Bad position</p> </div> <div style="text-align: center;">  <p>Good position</p> </div> </div>																		
<p>Standard</p>	<table border="1" style="width: 100%; border-collapse: collapse; text-align: center;"> <thead> <tr> <th>Status</th> <th>Resistance</th> <th>Result</th> <th>SVC Action</th> </tr> </thead> <tbody> <tr> <td rowspan="2">No magnet near the Switch</td> <td>$\infty \Omega$</td> <td>O.K.</td> <td>Go to 3</td> </tr> <tr> <td>$10 \Omega \downarrow$</td> <td>N.G.</td> <td>Go to 4</td> </tr> <tr> <td rowspan="2">Magnet is near the Switch</td> <td>$1 \Omega \downarrow$</td> <td>O.K.</td> <td>Go to 3</td> </tr> <tr> <td>$10 \Omega \uparrow$</td> <td>N.G.</td> <td>Go to 4</td> </tr> </tbody> </table>	Status	Resistance	Result	SVC Action	No magnet near the Switch	$\infty \Omega$	O.K.	Go to 3	$10 \Omega \downarrow$	N.G.	Go to 4	Magnet is near the Switch	$1 \Omega \downarrow$	O.K.	Go to 3	$10 \Omega \uparrow$	N.G.	Go to 4
Status	Resistance	Result	SVC Action																
No magnet near the Switch	$\infty \Omega$	O.K.	Go to 3																
	$10 \Omega \downarrow$	N.G.	Go to 4																
Magnet is near the Switch	$1 \Omega \downarrow$	O.K.	Go to 3																
	$10 \Omega \uparrow$	N.G.	Go to 4																

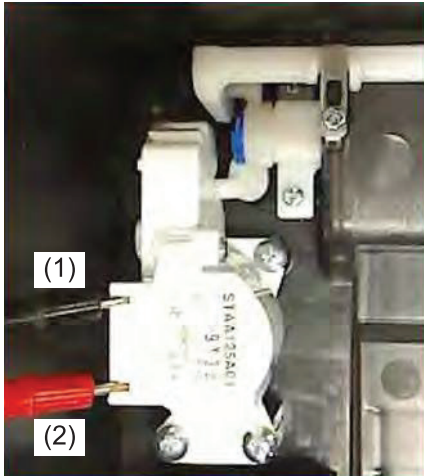

11-6 Dispenser DC Motor

Function	- Dispenser DC Motor : When customer push the dispenser button, Pull duct door and abstract from ice bank.				
How to Measure	<div style="text-align: center;">  <p>Dispenser DC Motor</p> </div>				
Standard	<p style="text-align: center;">Dispenser DC Motor</p> <table border="1" style="margin-left: auto; margin-right: auto;"> <thead> <tr> <th>Test Points</th> <th>Result</th> </tr> </thead> <tbody> <tr> <td>(1) to (2)</td> <td>8~13Ω</td> </tr> </tbody> </table>	Test Points	Result	(1) to (2)	8~13Ω
Test Points	Result				
(1) to (2)	8~13Ω				

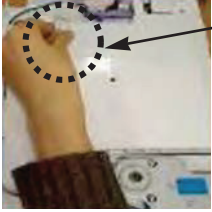
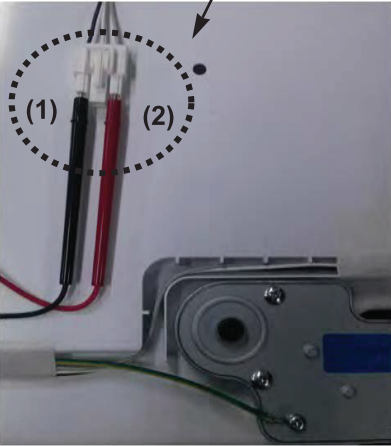
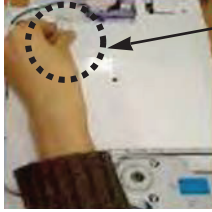
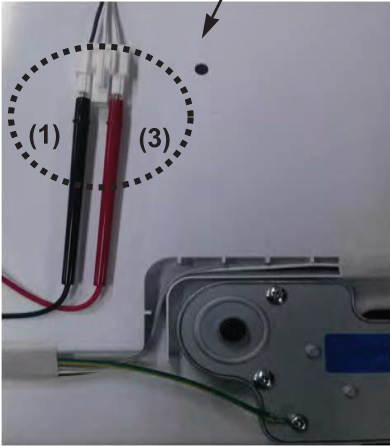
11-7 AC Motor ASSEMBLY

<p>Function</p>	<p>The motor in the door pushed the ice into the dispenser.</p>						
<p>How to Measure</p>	<div style="display: flex; justify-content: space-around;"> <div style="text-align: center;"> <p>< In-door Motor ></p>  <p>① Separate the housing.</p>  <p>② Measure the resistance between (1) and (2)</p> </div> <div style="text-align: center;"> <p>< In-door Motor ></p>  <p>① Separate the housing.</p>  <p>② Measure the resistance between (1) and (3)</p> </div> </div> <p>Check the resistance between connectors (In-door motor 1, 2) and (In-door motor 1, 3). It means check whether or not applying an Electric current. If there is resistance, it means the geared motor or solenoid is not inferiority</p>						
<p>Standard</p>	<p style="text-align: center;">Geared Motor (Crush mode)</p> <table border="1" style="margin-left: auto; margin-right: auto;"> <thead> <tr> <th>Test Points</th> <th>Result</th> </tr> </thead> <tbody> <tr> <td>(1) to (2)</td> <td>18~40Ω</td> </tr> <tr> <td>(1) to (3)</td> <td>18~40Ω</td> </tr> </tbody> </table>	Test Points	Result	(1) to (2)	18~40Ω	(1) to (3)	18~40Ω
Test Points	Result						
(1) to (2)	18~40Ω						
(1) to (3)	18~40Ω						

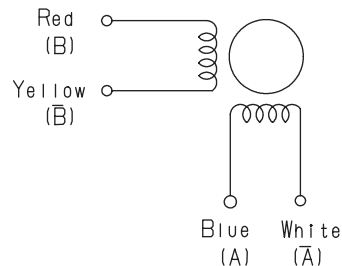
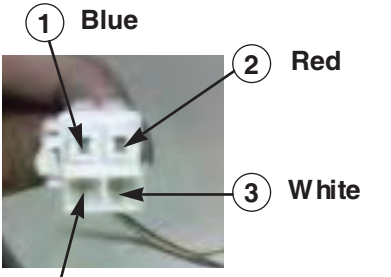
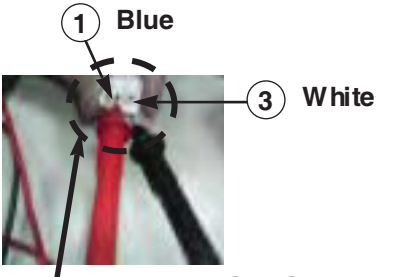

11-8 Damper

<p>Function</p>	<p>The damper supplies cold air from the freezer to the chill room using the damper plate. The chill room is colder when the damper plate is open. When the damper is closed the chill rooms temperature will rise.</p>																													
<p>How to Measure</p>	<div style="display: flex; justify-content: space-around;"> <div data-bbox="354 500 852 883"> <p>Table(1): 결선도(Wiring)</p>  </div> <div data-bbox="868 500 1453 883"> <p>Table(2): 2-2상 여자순서(CW Rotation)</p> <table border="1" data-bbox="876 563 1347 819"> <thead> <tr> <th rowspan="2">Housing No. & L/Wire Color</th> <th colspan="4">Step</th> </tr> <tr> <th>1</th> <th>2</th> <th>3</th> <th>4</th> </tr> </thead> <tbody> <tr> <td>1- Blue (A)</td> <td>+</td> <td>-</td> <td>-</td> <td>+</td> </tr> <tr> <td>2- Red (B)</td> <td>+</td> <td>+</td> <td>-</td> <td>-</td> </tr> <tr> <td>3- White(A)</td> <td>-</td> <td>+</td> <td>+</td> <td>-</td> </tr> <tr> <td>4- Yellow(B)</td> <td>-</td> <td>-</td> <td>+</td> <td>+</td> </tr> </tbody> </table> </div> </div> <p style="text-align: center;">< Damper Circuit ></p> <div style="display: flex; justify-content: space-around;"> <div data-bbox="354 957 755 1276">  <p>Check the ② ④</p> </div> <div data-bbox="1023 957 1453 1276">  <p>Check the ① ③</p> </div> </div> <p style="text-align: center;">< extension ></p> <div style="display: flex; justify-content: space-around;"> <div data-bbox="354 1340 755 1617">  </div> <div data-bbox="1023 1340 1453 1617">  </div> </div> <p>Check to see if there is electrical current, if there is resistance the damper is good.</p>	Housing No. & L/Wire Color	Step				1	2	3	4	1- Blue (A)	+	-	-	+	2- Red (B)	+	+	-	-	3- White(A)	-	+	+	-	4- Yellow(B)	-	-	+	+
Housing No. & L/Wire Color	Step																													
	1	2	3	4																										
1- Blue (A)	+	-	-	+																										
2- Red (B)	+	+	-	-																										
3- White(A)	-	+	+	-																										
4- Yellow(B)	-	-	+	+																										
<p>Standard</p>	<table border="1" style="width: 100%;"> <thead> <tr> <th colspan="2" style="text-align: left;">Damper</th> <th colspan="2"></th> </tr> <tr> <th>Test Points</th> <th>Result</th> <th>Test Points</th> <th>Result</th> </tr> </thead> <tbody> <tr> <td>Red and Yellow</td> <td>373 ~ 456 Ω</td> <td>Blue and White</td> <td>373 ~ 456 Ω</td> </tr> </tbody> </table>	Damper				Test Points	Result	Test Points	Result	Red and Yellow	373 ~ 456 Ω	Blue and White	373 ~ 456 Ω																	
Damper																														
Test Points	Result	Test Points	Result																											
Red and Yellow	373 ~ 456 Ω	Blue and White	373 ~ 456 Ω																											

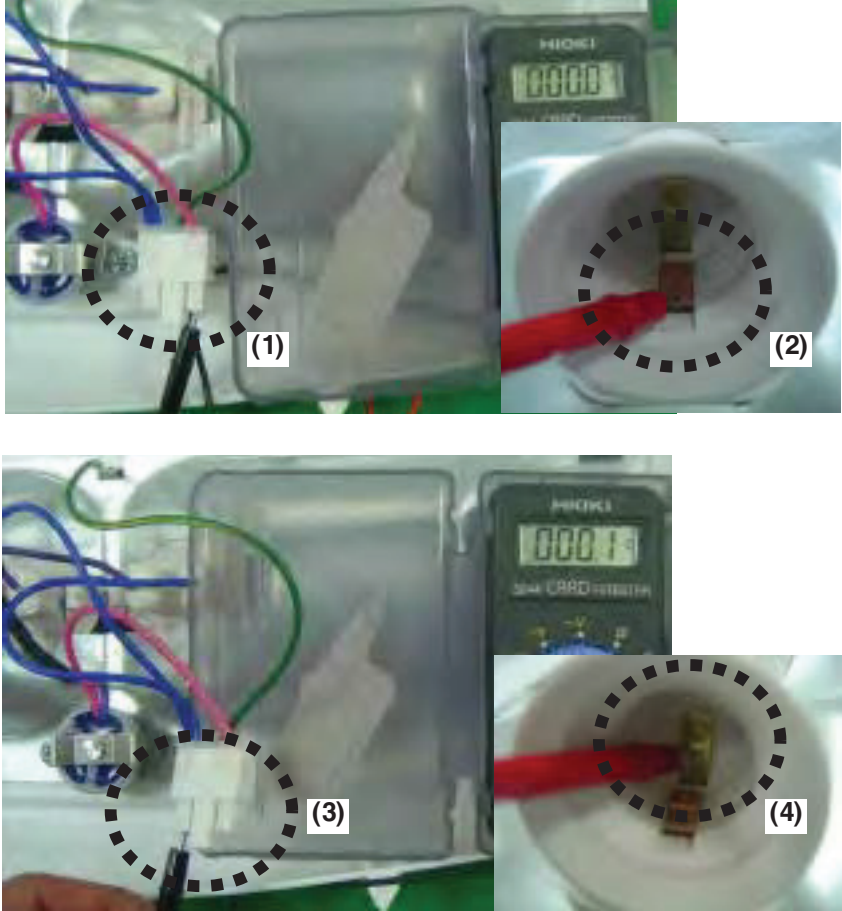
11-9 Lamp Socket

<p>Function</p>	<p>The lamp socket connect cover lamp assembly to lamp. The lamp socket fix lamp and unite lamp and cover lamp assembly. The lamp socket supply electric source to lamp also.</p>				
<p>How to Measure</p>	<div style="text-align: center;">  </div> <p>Check the resistance between connector of housing and connector of lamp socket. It means check whether or not applying an electric current. If there is resistance it means the lamp socket is good.</p>				
<p>Standard</p>	<table border="1" style="margin-left: auto; margin-right: auto;"> <thead> <tr> <th>Test Points</th> <th>Result</th> </tr> </thead> <tbody> <tr> <td>(1) to (2) and (3) to (4)</td> <td>0 Ω</td> </tr> </tbody> </table>	Test Points	Result	(1) to (2) and (3) to (4)	0 Ω
Test Points	Result				
(1) to (2) and (3) to (4)	0 Ω				

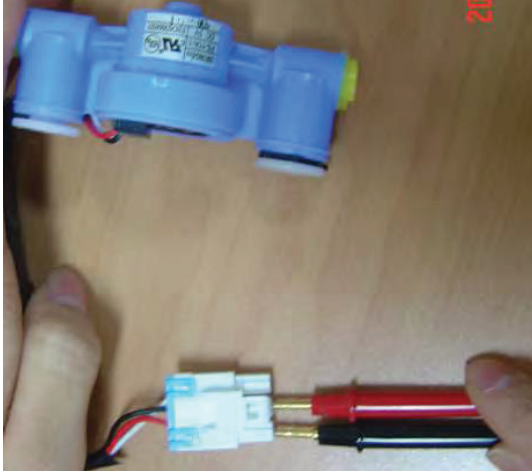
11-10 Flow Sensor

Function	Flow Sensor (in machine room) Count the water quantity from city water to water filter in refrigerator					
How to Measure	<div style="display: flex; justify-content: space-around; align-items: center;">   </div> <p style="text-align: center;">Flow Sensor (in machine room)</p>					
Standard	<table border="1" style="margin-left: auto; margin-right: auto;"> <thead> <tr> <th>Test Points</th> <th>Result</th> </tr> </thead> <tbody> <tr> <td>Red wire to Black wire</td> <td>4 ~ 30 kΩ</td> </tr> </tbody> </table>		Test Points	Result	Red wire to Black wire	4 ~ 30 kΩ
Test Points	Result					
Red wire to Black wire	4 ~ 30 kΩ					

12. Compressor Troubleshooting

PCB Check (Simplify)

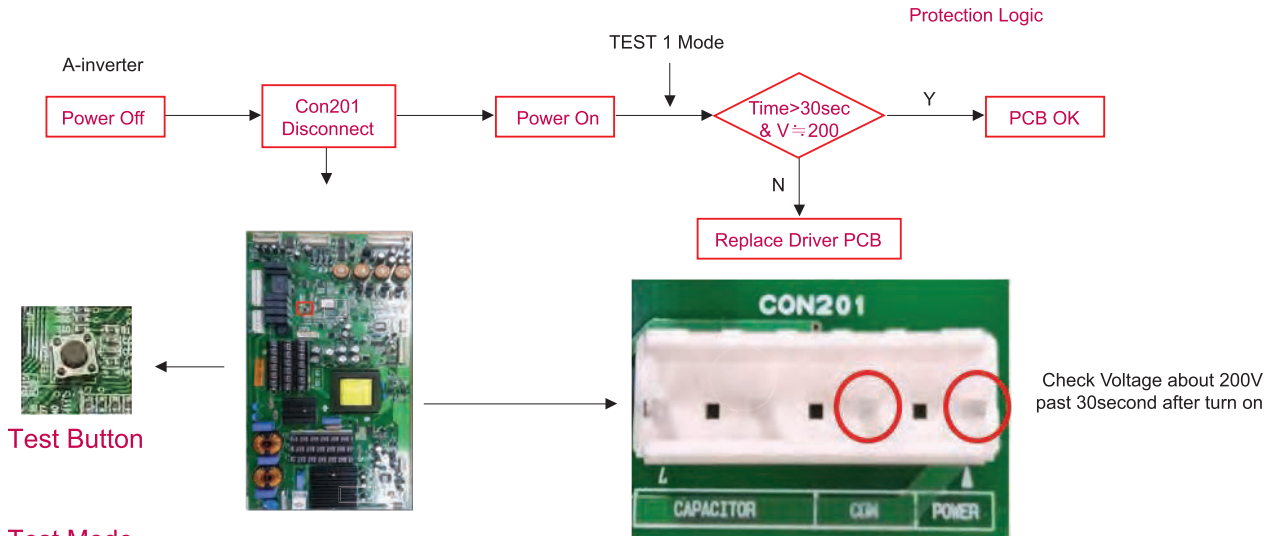

Test Mode

	Ref.	COMP	Display & sound	Refer
		FLB075(A-Inverter)		
TEST1	Forced Starting	TDC (Full Stroke)	Display ON, Buzz 1 time	

Troubleshooting

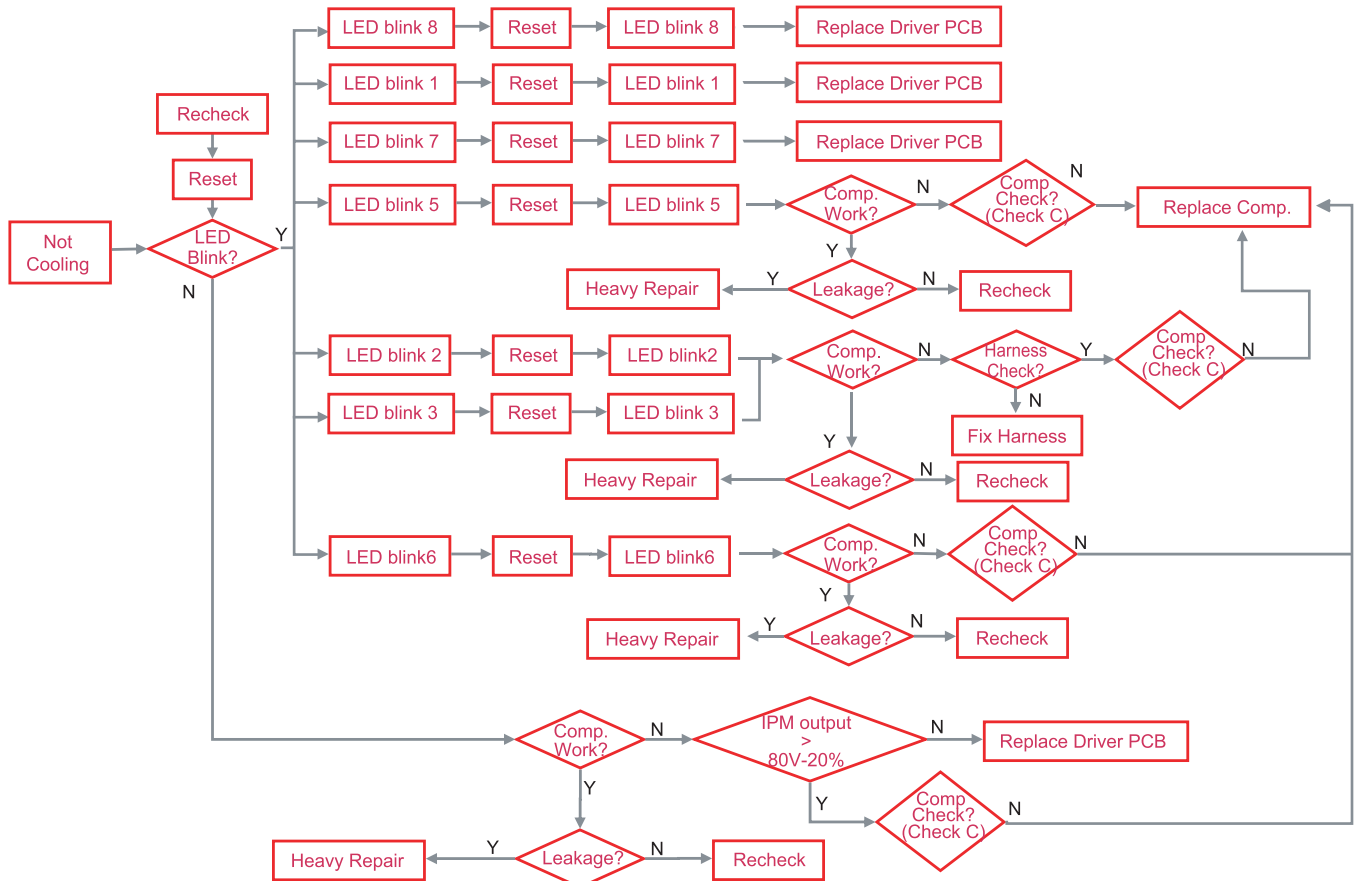

12-1 Check A

- There is PC Board located in the PCB case.
The control driver is PC board for the compressor.
- This step shows the source voltage of the driver PC board.

Step1. Open PCB Cover



Step2. Check Driver PCB



LED Lamp

- * Driver PCB located in back plate cover of the refrigerator.

IPM Output check

- Measure the voltage between the POWER and COMM pins of the connector as shown below.

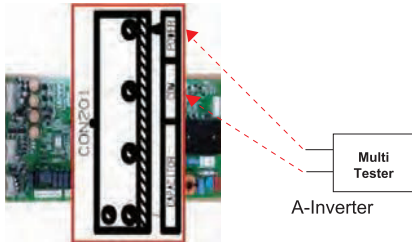

Check to make sure compressor is receiving voltage from IPM

- In order to determine whether the compressor is operating normally, check the output voltage during the refrigeration cycle.
- After initial power-up, when the compressor begins to operate, wait 10 minutes before checking.
- The compressor is operating normally if the voltage is greater than 80V.

12-2 Check B

B1. LED blinks once, then repeats (FCT0 Fault)

Protection Logic



Blink OFF Blink OFF

- Purpose: Detecting motor current and voltage error
- Check voltage at point A(Motor Voltage), point B(Motor Current) andP oint C (Capacitor Voltage) when compressor is off.
- Spec: Points A, B, & C $2.5V \pm 0.3V$

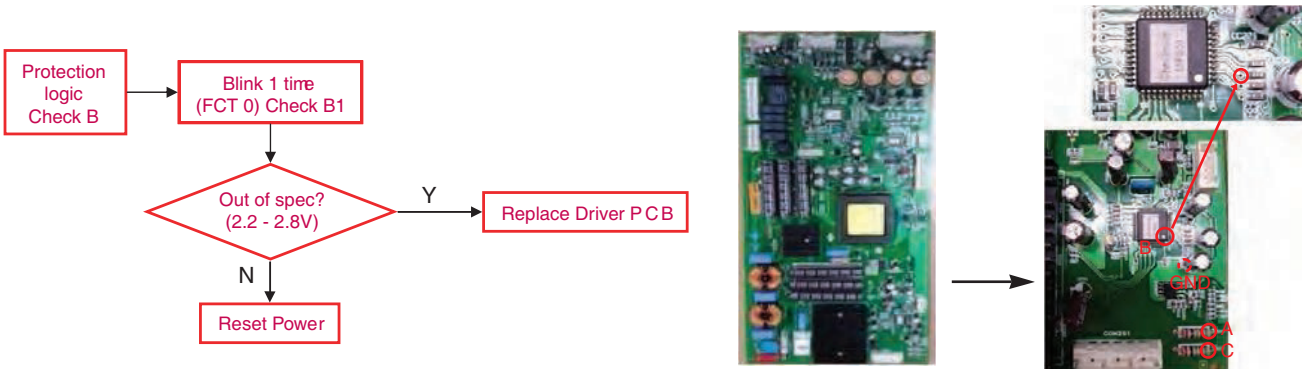

※ Devices should not be short-circuited when you check C

B2. LED blinks two times, then repeats (Stroke Trip)

Protection Logic



Blink Blink OFF Blink Blink OFF

- Purpose : Prevent abnormally long piston strokes.
- Case 1. If compressor doesn't work and LED blinks - Cause: Possibly harness from compressor to PCB might be defective.
- Case 2. If compressor works intermittently and LED blinks - Cause: Condenser Fan or Freezer Fan is not running. Sealed system problem such as moisture restriction, restriction at capillary tube or refrigerant leak.
- Logic: Compressor is forced to off and then tries to restart after 1 minute.

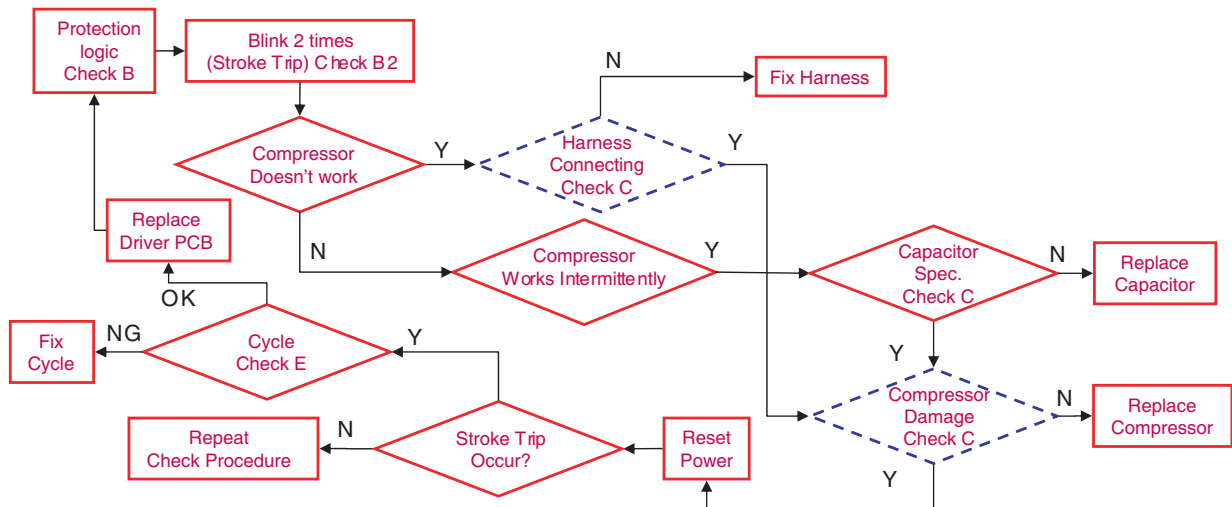

B3. LED blinks three times, then repeats (Stroke Trip)

Protection Logic



Blink Blink Blink OFF Blink Blink Blink OFF

- Purpose: Prevent over voltage and current detecting connecting error.
- Cause: -. Connecting error of PCB and Comp, Capacitor Harness -. Comp insulation damage.
- Logic: Compressor is forced off and tries to restart within 40 seconds.

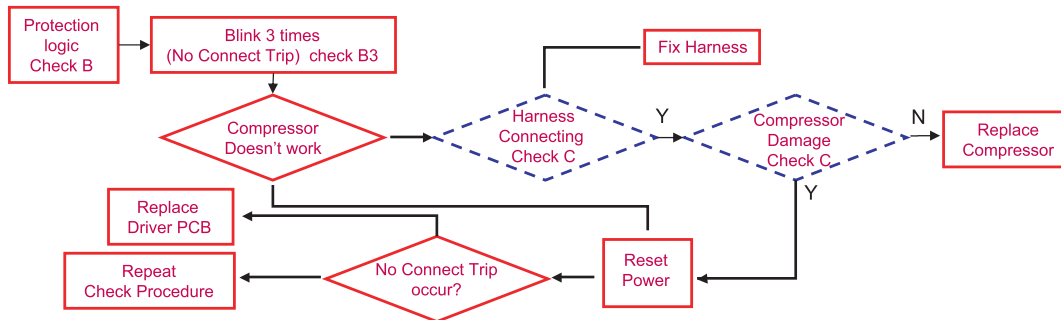

B4. LED blinks five times, then repeats (Locked Piston)

Protection Logic



Blink Blink Blink Blink Blink OFF

- Purpose: To detect locked piston
- Cause: Lack of oil to the cylinder, cylinder or piston damaged and or restricted discharge. A Locked Piston can also be caused by foreign materials inside the compressor.
- Logic: Compressor is forced off and tries to restart within 2.5 minutes.

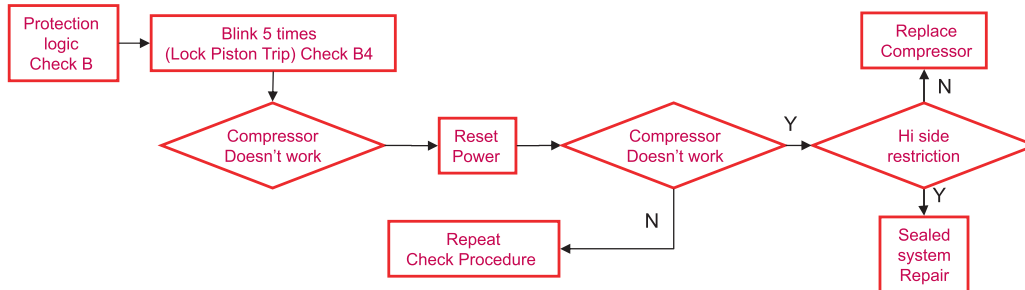

B5. LED blinks six times, then repeats (Current Trip)

Blink Blink Blink Blink Blink Blink OFF

- Purpose: Prevent over-current (overload protect)
- Cause: Ambient temperature is high (over 43°C) and/or refrigerator's condenser air movement is restricted.
- Condenser Fan is stopped, restricted discharge line, compressor is damaged, or IPM device is defective.
- Logic: Compressor is forced off and tries to restart after 6 minutes.

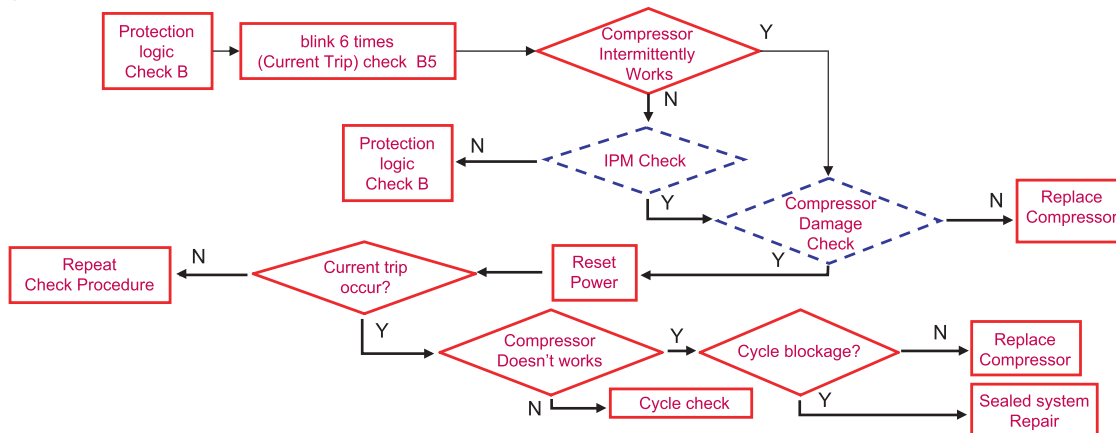

B6. LED blinks seven times, then repeats



Blink Blink Blink Blink Blink Blink OFF

- Purpose : Prevent high current due to IPM Short
- Cause : Damaged IPM (Dead Short)
- Test for a dead short at Point A with a VOM.
- Logic : Compressor is forced off and tries to restart in 20seconds.

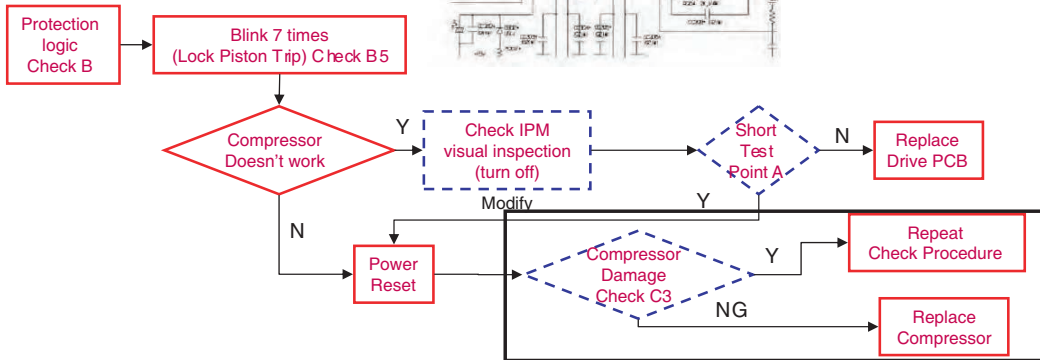
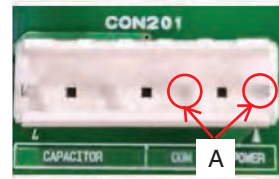
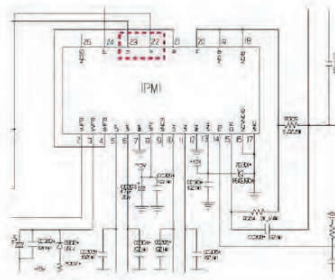

B7.LED Blinks eight times, then repeats (Communication Error)



Blink Blink Blink Blink Blink Blink Blink F F O

- Purpose : To detect Set control Micom and communication error
- Cause : Communication Error
- Logic : LED blink. (Compressor runs reference value before occuring communication Error)

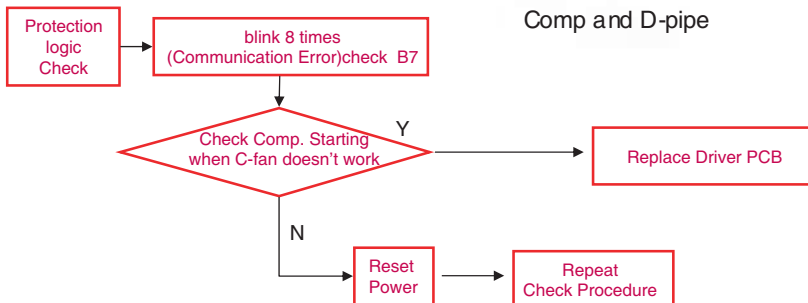
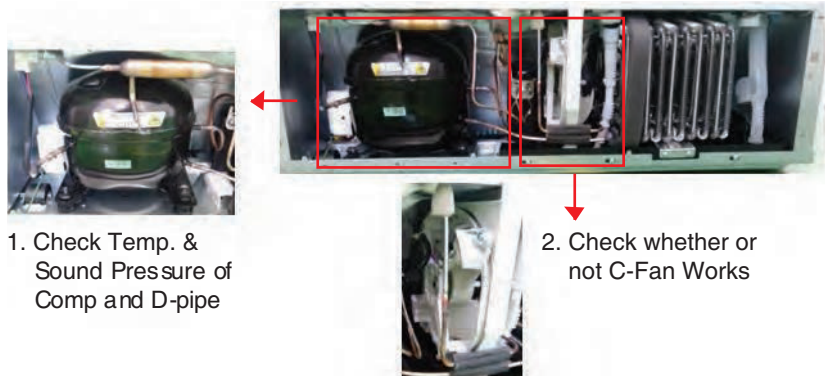

12-3 Check C

- C1. Harness Connection Check
- C2. Capacitor Specifications
- C3. Compressor Check

Check Process

- Step 1. Power off. Step 2. Check capacitor spec. (table1). Step3. Check resistance of point A
- Step 4. Check wire harness (INF ohm). Step 5. Check resistance at point B. Step 6. Point D.

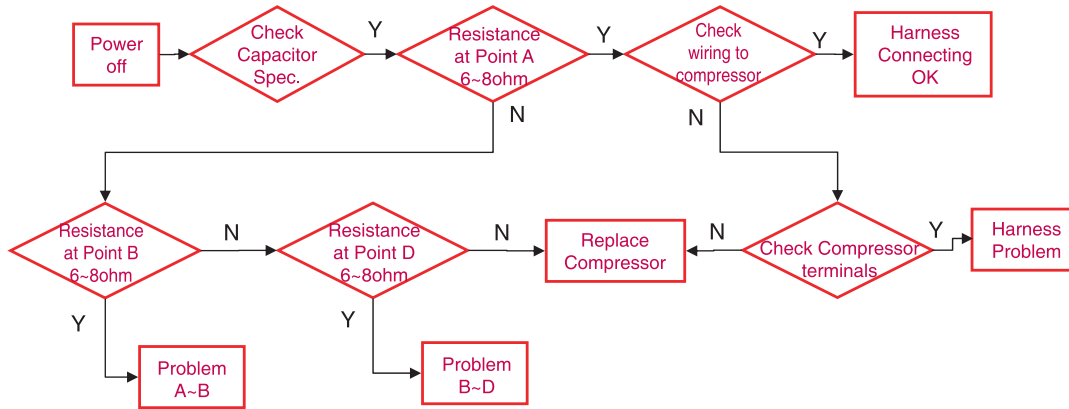

Caution : Turn off power during check C

- Measure the resistance at each point except point C
- Dead short check: measure the resistance between power line in compressor and earth ground in refrigerator (Inf. Ohm)

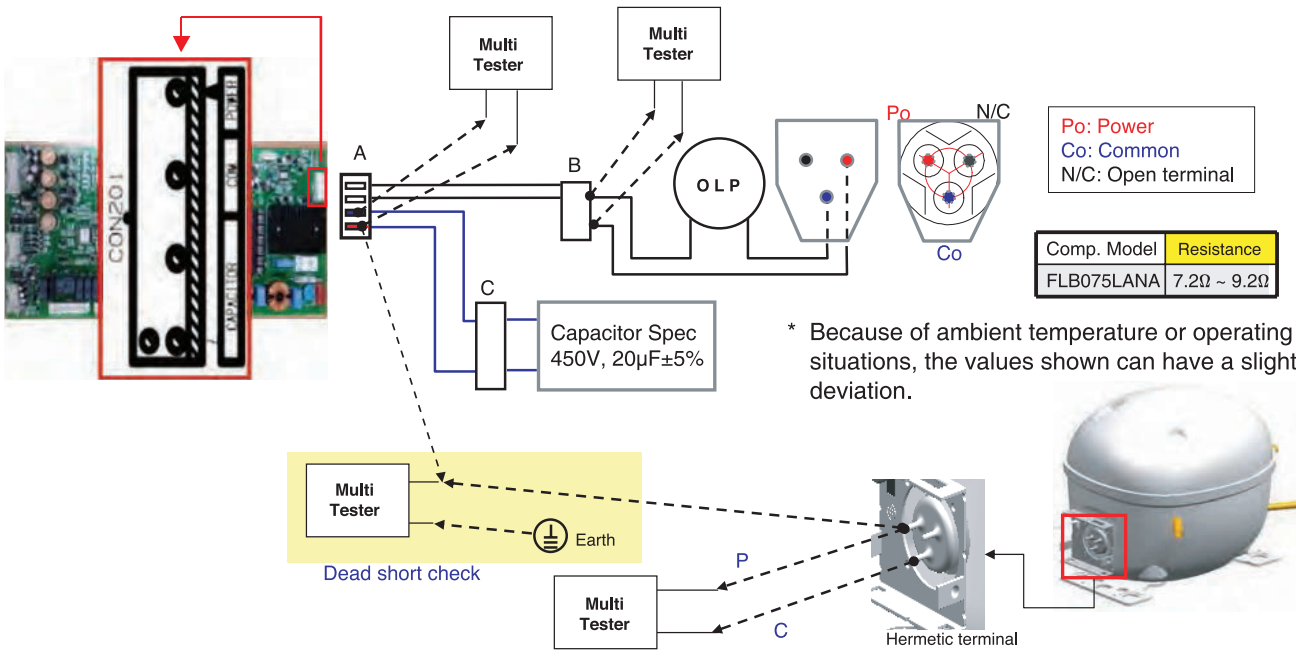

12-4 Check D

D1. Activate Protection logic

Cycle check with protection logic

- We have to check Condenser fan and Freezer fan before performing Check D
- Locked Piston, Current trip and stroke trip can be activated by other problems than the driver or compressor.

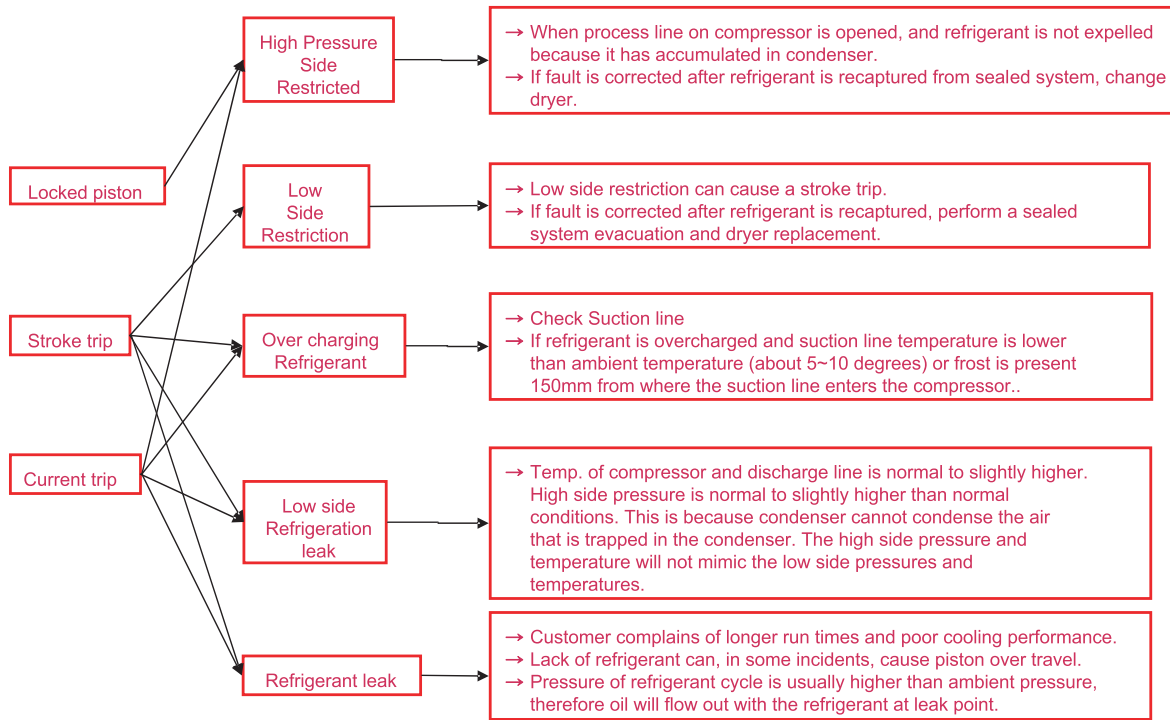

D2. sealed system diagnosis

- Check as follows;

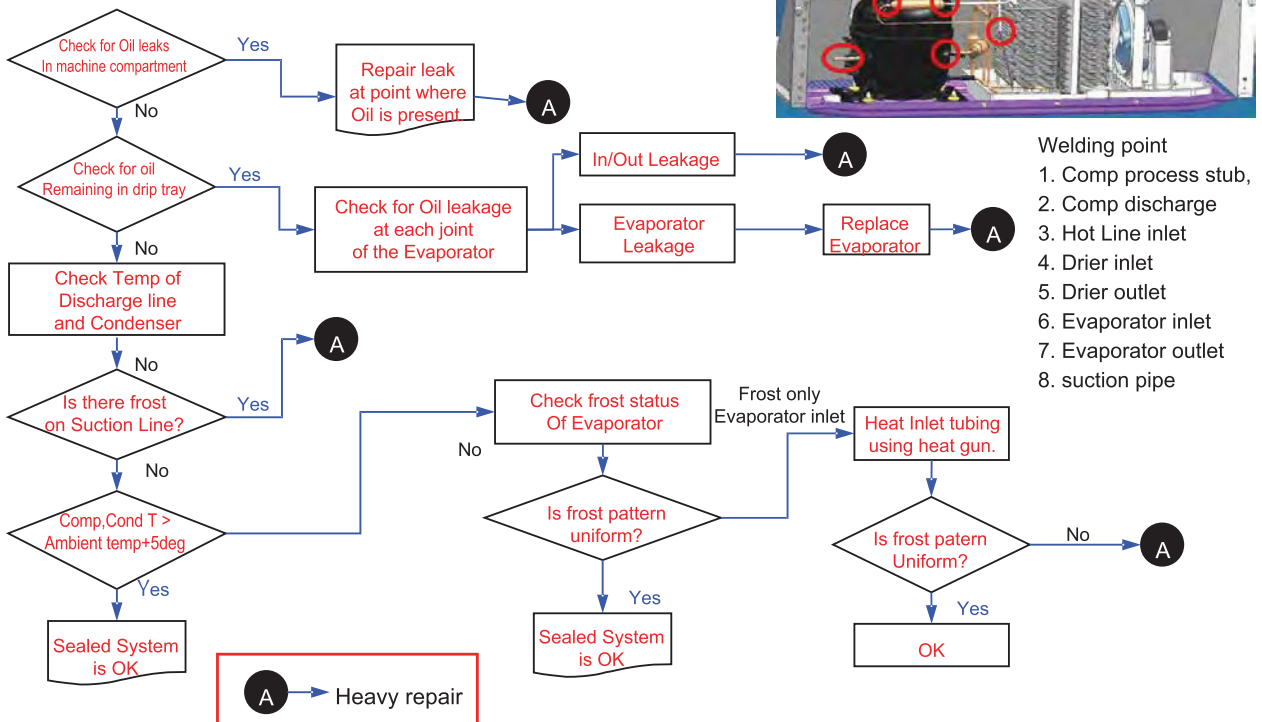

Compressor Troubleshooting

⚠ WARNING HIGH VOLTAGE

Step 1) Open PCB cover





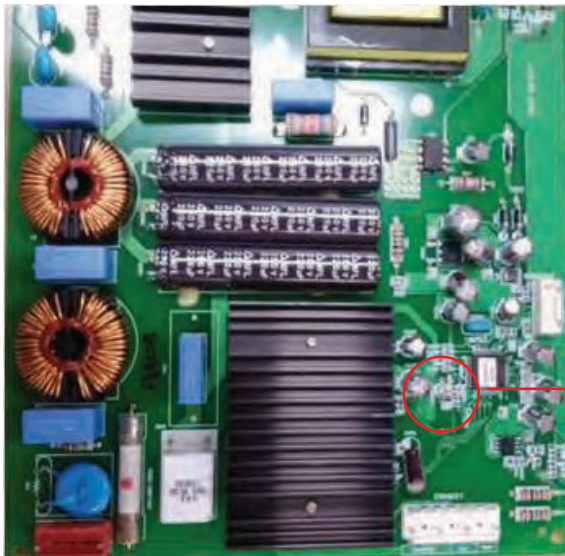

Step 2) Check for blinking frequency of LED and PCB



LED Lamp

When compressor is normal, it does not blink
: Refer to the next page to find out what actions to take according to how many times LED blink

No	LED operating condition	Cause	Service guideline
1	<p>LED two - time repetition (Stroke Trip)</p>  <p>..on - on - off - on - on - off - on - on - off ..repeating</p>	PCB Parts defect or Compress or Connector miss connecting (Piston over run)	<ol style="list-style-type: none"> 1. Please check, Whether connector of compressor is attached rightly or not. after power off 2. After the first action, You check on normal operation of compressor. 3. If the same symptom arises after the second action, replace PCB
2	<p>LED five - time repetition (Piston Lock Trip)</p>  <p>..on - on - on - on - on - off - on - on - on - on - on - off ..repeating</p>	Piston constraint	<ol style="list-style-type: none"> 1. After resetting power, check if it is running normal 2. If the same symptom arises after the first action 3. If the same symptom arises after the second action, replace compressor
3	<p>LED six - time repetition (Current Trip)</p>  <p>..on - on - on - on - on - on - off - on - on - on - on - on - off ..repeating</p>	Circuit over current error Or cycle error	<ol style="list-style-type: none"> 1. After resetting power, check if it is running normal 2. If the same symptom arises after the first action 3. If the same symptom arises after the second action, replace compressor
4	<p>LED seven - time repetition (IPM Fault Trip)</p>  <p>..on - on - on - on - on - on - on - off - on - on - on - on - on - on - off ..repeating</p>	PCB parts defect (IPM)	<ol style="list-style-type: none"> 1. After resetting power, check if it is running normal 2. If the same symptom arises after the first action, replace PCB

12-5 SERVICE DIAGNOSIS CHART

COMPLAINT	POINTS TO BE CHECKED	REMEDY
No Cooling.	<ul style="list-style-type: none"> Is the power cord unplugged from the outlet? Check if the power switch is set to OFF. Check if the fuse of the power switch is shorted. Measure the voltage of the power outlet. 	<ul style="list-style-type: none"> Plug into the outlet. Set the switch to ON. Replace the fuse. If the voltage is low, correct the wiring.
Cools poorly.	<ul style="list-style-type: none"> Check if the unit is placed too close to the wall. Check if the unit is placed too close to the stove, gas cooker, or in direct sunlight. Is the ambient temperature too high or the room door closed? Check if food put in the refrigerator is hot. Did you open the door of the unit too often or check if the door is sealed properly? Check if the Control is set to Warm position. 	<ul style="list-style-type: none"> Place the unit about 4 inches (10 cm) from the wall. Place the unit away from these heat sources. Lower the ambient temperature. Put in foods after they have cooled down. Don't open the door too often and close it firmly. Set the control to Recommended position.
Food in the Refrigerator is frozen.	<ul style="list-style-type: none"> Is food placed in the cooling air outlet? Check if the control is set to colder position. Is the ambient temperature below 41°F(5°C)? 	<ul style="list-style-type: none"> Place foods in the high-temperature section. (front part) Set the control to Recommended position. Set the control to Warm position.
Condensation or ice forms inside the unit.	<ul style="list-style-type: none"> Is liquid food sealed? Check if food put in the refrigerator is hot. Did you open the door of the unit too often or check if the door is sealed properly? 	<ul style="list-style-type: none"> Seal liquid foods with wrap. Put in foods after they have cooled down. Don't open the door too often and close it firmly.
Condensation forms in the Exterior Case.	<ul style="list-style-type: none"> Check if the ambient temperature and humidity of the surrounding air are high. Is there a gap in the door gasket? 	<ul style="list-style-type: none"> Wipe moisture with a dry cloth. It will disappear in low temperature and humidity. Fill up the gap.
There is abnormal noise.	<ul style="list-style-type: none"> Is the unit positioned in a firm and even place? Are any unnecessary objects placed in the back side of the unit? Check if the Drip Tray is not firmly fixed. Check if the cover of the compressor enclosure in the lower front side is taken out. 	<ul style="list-style-type: none"> Adjust the Leveling Screw, and position the refrigerator in a firm place. Remove the objects. Fix the Drip Tray firmly in the original position. Place the cover in its original position.
Door does not close well.	<ul style="list-style-type: none"> Check if the door gasket is dirty with an item like juice. Is the refrigerator level? Is there too much food in the refrigerator? 	<ul style="list-style-type: none"> Clean the door gasket. Position in a firm place and level the Leveling Screw. Make sure food stored in shelves does not prevent the door from closing.
Ice and foods smell unpleasant.	<ul style="list-style-type: none"> Check if the inside of the unit is dirty. Are foods with a strong odor unwrapped? The unit smells of plastic. 	<ul style="list-style-type: none"> Clean the inside of the unit. Wrap foods that have a strong odor. New products smell of plastic, but this will go away after 1-2 weeks.

● Other possible problems:

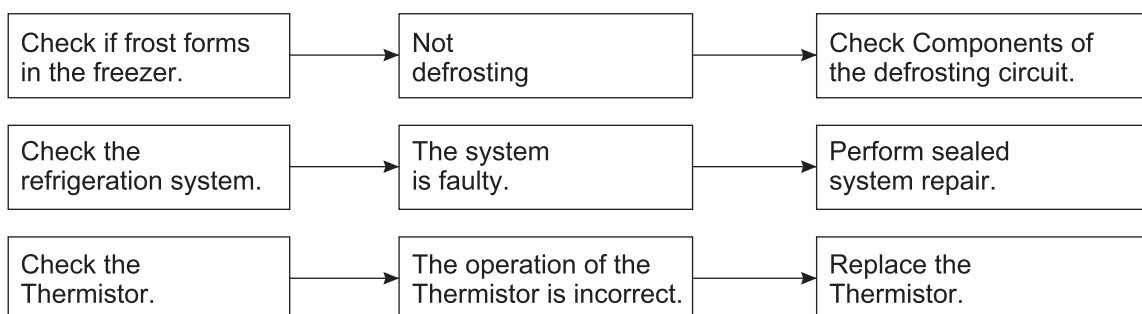

12-6 REPRIGERATOR CYCLE

▼ Troubleshooting Chart

CAUSE		STATE OF THE UNIT	STATE OF THE EVAPORATOR	TEMPERATURE OF THE COMPRESSOR	REMARKS
LEAKAGE	PARTIAL LEAKAGE	Freezer compartment and Refrigerator don't cool normally.	Low flowing sound of Refrigerant is heard and frost forms in inlet only.	A little higher than ambient temperature.	<ul style="list-style-type: none"> Refrigerant level is low due to a leak. Normal cooling is possible by restoring the normal amount of refrigerant and repairing the leak.
	COMPLETE LEAKAGE	Freezer compartment and Refrigerator don't cool normally.	Flowing sound of refrigerant is not heard and frost isn't formed.	Equal to ambient temperature.	<ul style="list-style-type: none"> No discharging of Refrigerant. Normal cooling is possible by restoring the normal amount of refrigerant and repairing the leak.
CLOGGED BY DUST	PARTIAL CLOG	Freezer compartment and Refrigerator don't cool normally.	Flowing sound of refrigerant is heard and frost forms in inlet only.	A little higher than ambient temperature.	<ul style="list-style-type: none"> Normal discharging of the refrigerant. The capillary tube is faulty.
	WHOLE CLOG	Freezer compartment and Refrigerator don't cool.	Flowing sound of refrigerant is not heard and frost isn't formed.	Equal to ambient temperature.	<ul style="list-style-type: none"> Normal discharging of the Refrigerant.
MOISTURE CLOG		Cooling operation stops periodically.	Flowing sound of refrigerant is not heard and frost melts.	Lower than ambient temperature.	<ul style="list-style-type: none"> Cooling operation restarts when heating the inlet of the capillary tube.
DEFECTIVE COMPRESSION	COMP-RESSION	Freezer and Refrigerator don't cool.	Low flowing sound of refrigerant is heard and frost forms in inlet only.	A little higher than ambient temperature.	<ul style="list-style-type: none"> Low pressure at high side of compressor due to low refrigerant level.
	NO COMP-RESSION	No compressing operation.	Flowing sound of refrigerant is not heard and there is no frost.	Equal to ambient temperature.	<ul style="list-style-type: none"> No pressure in the high pressure part of the compressor.

12-6-1 Cleaning

There is no need for routine condenser cleaning in normal Home operating environments. If the environment is particularly greasy or dusty, or there is significant pet traffic in the home, the condenser should be cleaned every 2 to 3 months to ensure maximum efficiency.

If you need to clean the condenser:

- Remove the mechanical cover.
- Use a vacuum cleaner with a soft brush to clean the grille, the open areas behind the grille and the front surface area of the condenser.
- Replace the mechanical cover.

12-6-2 SEALED SYSTEM DIAGNOSIS

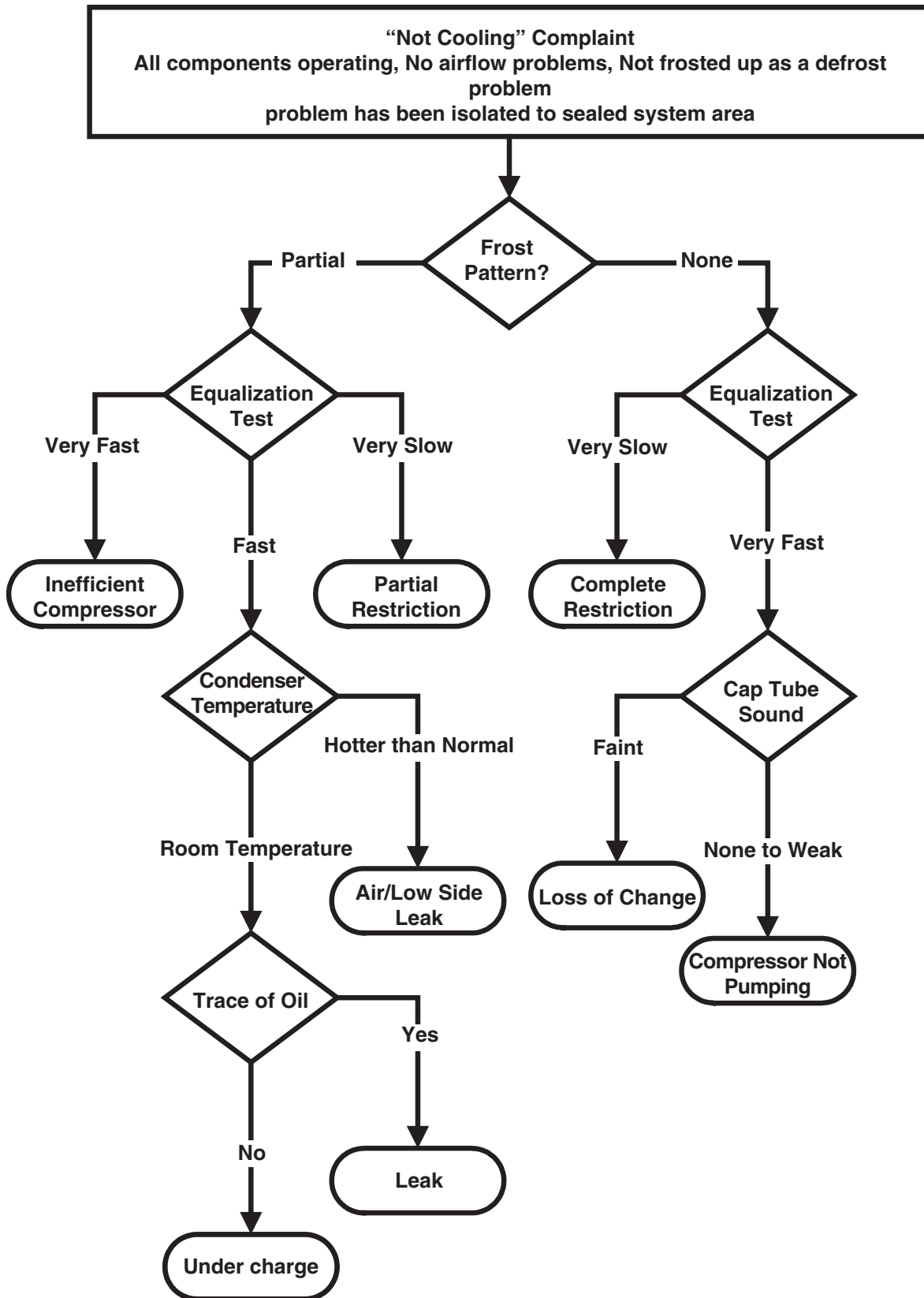

(The equalization test is trying to restart a compressor using a start kit after it has been operating.)

13. ICEMAKER OPERATING METHOD AND TROUBLE SHOOTING

13-1 Icemaker's Basic Operating Method

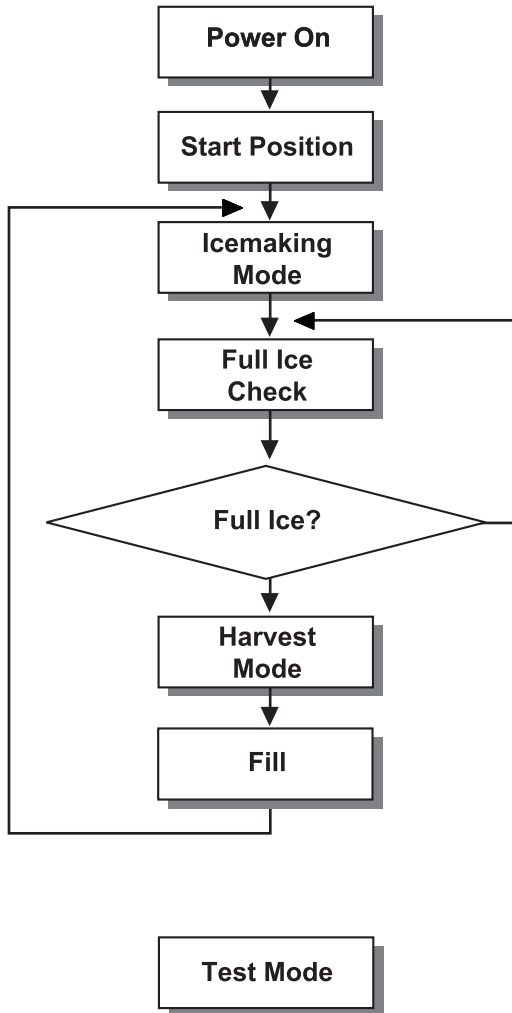

• Adjusts Ice Tray to Start Position with power on.



• Waits until water becomes ice.
 ※ For cold air circulation, Ice tray will be on a slightly tilt one hour after ice-making mode begins. Atilt ice tray means icemaker's normal operation.



• If water becomes ices in the ice tray, Ice-detecting sensor check if the ice bin is full.



• Twist the ice tray to drop ice into the ICE BIN.



• Supply water to the ice tray by operating the solenoid valve.



• To force water to supply to the ice tray, or check icemaker's condition press and hold the **FILL Key** for about 3seconds.
 In the test mode, The icemaker will run through 3 stages step by step
 : **Harvest** → **Fill water** → **Ice making**

To reset the icemaker's operation, set the power switch OFF position and back it to ON position.

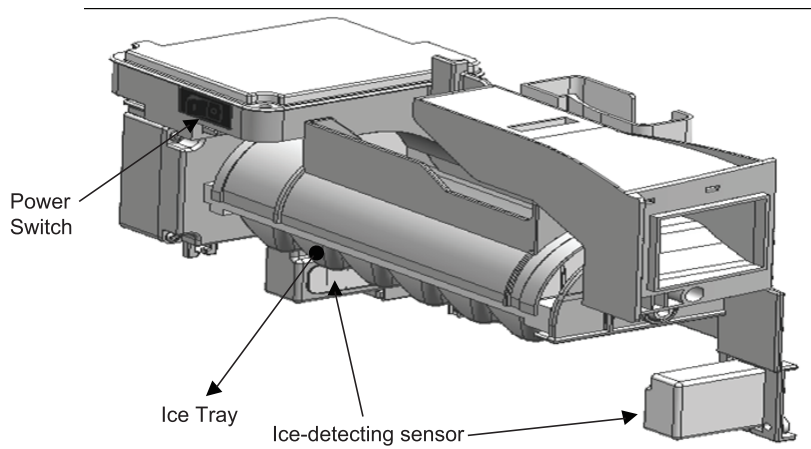

Icemaker Unit

13-2 ICEMAKER FUNCTIONS

13-2-1 Icemaking Mode

1. Icemaking Mode begins right after the ice tray fills with water.
 2. Icemaker waits until water becomes ice in the ice tray.
- ※ Ice-detecting sensor checks if the ice bin is full every 2min.

13-2-2 Harvest Mode

At least in 110min, since icemaker begun icemaking mode, Icemaker starts to twist the ice tray to drop ices into the Ice bin.
(After installation, at least 1day is needed to make ices)

- ※ If the icemaker never drop ices to the ice bin though water becomes ices in the ice tray, check the real temperature of compartment. (not temperature on display)
Icemaker needs below 0°F to drop ices to ice bin.

13-2-3 Fill/Park Position

Once the normal harvest mode has been completed, the water solenoid will be activated.

13-3 Trouble Shooting Ice & Water System Issues

13-3-1 Icemaker not making ice or not making enough ice (Environmental Diagnosis)

- Icemaker can't make ices itself. Basically, water, temperature and time are needed.
- Water : If no Water, then no Ice.
 - Temperature : The compartment, where the icemaker is located, has to be at least 1°F so that icemaker dumps ices to the bin.
 - Time : At least 80 minutes must be passed to make one series of ices after water comes into icemaker.
- ※ **Test Mode should not be carried out before checking below.**

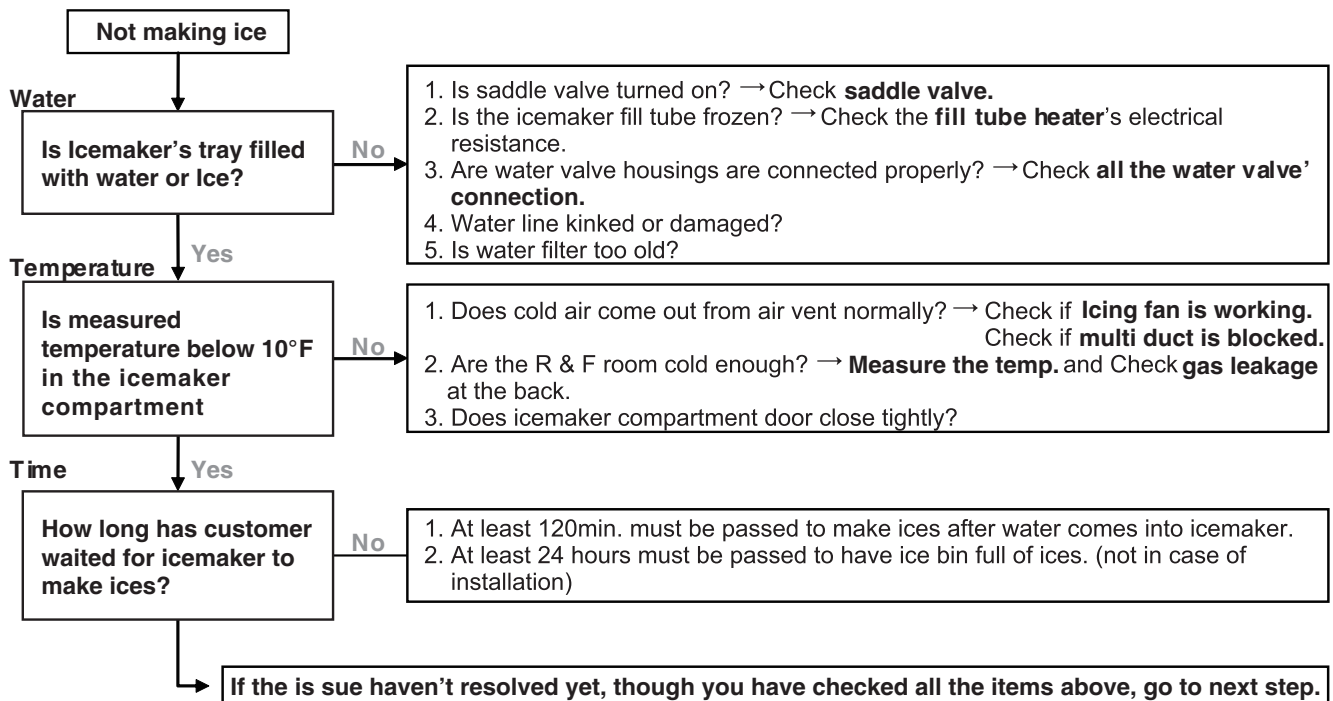

13-3-2 Icemaker not making ice or not making enough ice (Icemaker Unit & Ice-detecting sensor Diagnosis)

► Icemaker Unit and Ice-detecting sensor Diagnosis

The icemaker unit and Ice-detecting sensor is programmed to be diagnosed.

Follow the procedure step by step to check to see if icemaker and Ice-detecting sensor is working normally.

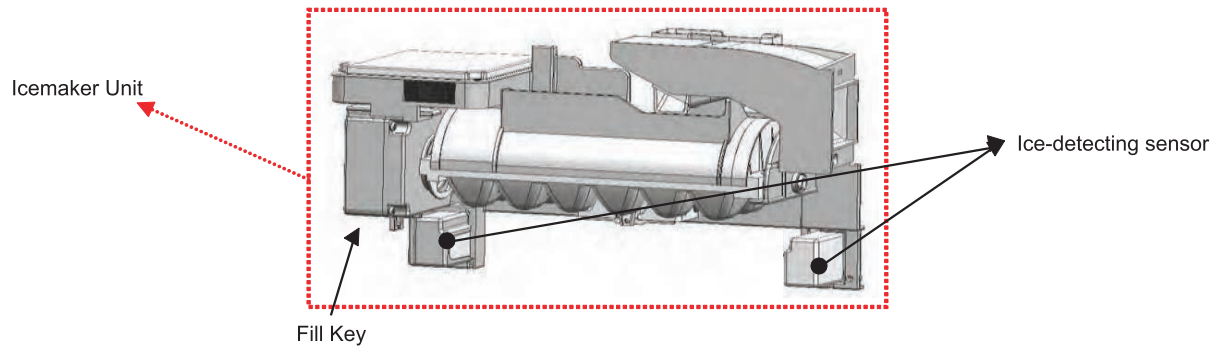

1st STEP (Icemaker Unit Diagnosis)

Press the fill key for about 3sec. If the icemaker runs 2 stages of harvest and filling water step by step, It means icemaker's mechanism is normal.

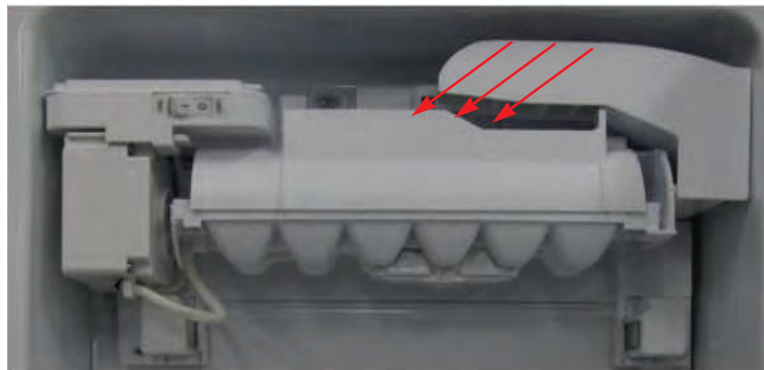

※ Caution : Be sure that the ice tray is not filled with water before pressing fill key.

2st STEP (Ice-detecting sensor Diagnosis)

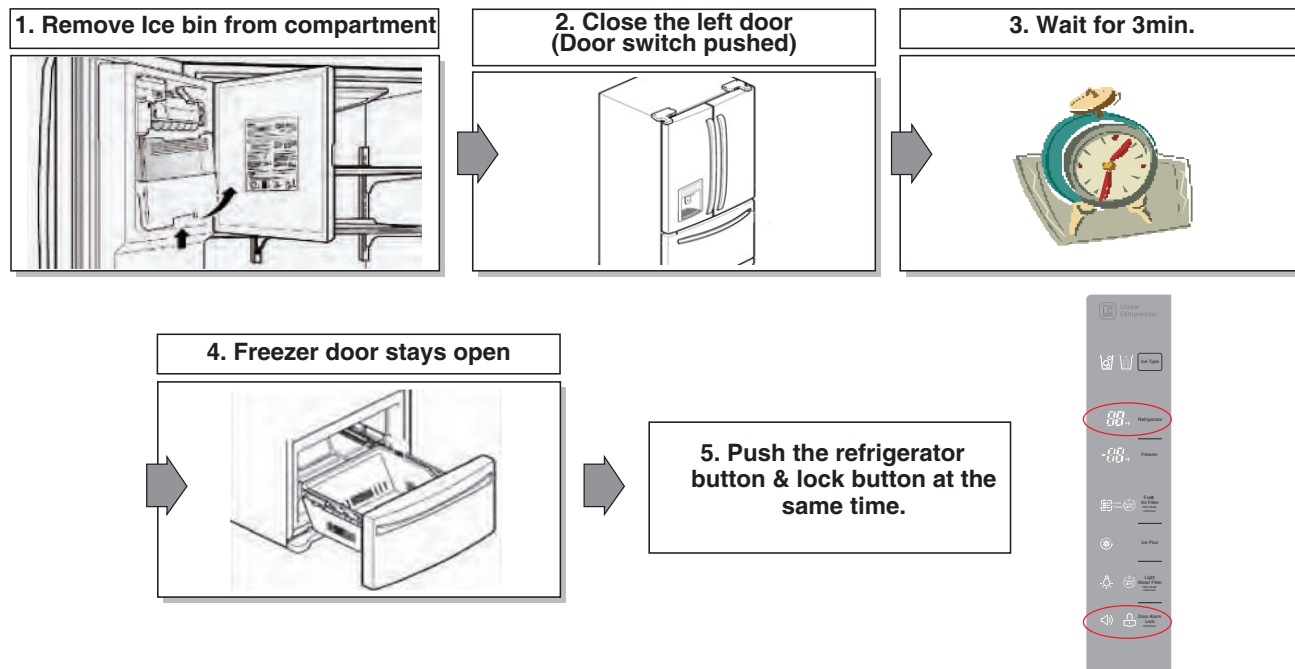

If **"ETY"** is shown on the display after the procedure above, Ice-detecting sensor is **normal**.
If **"FULL"** is shown on the display after the procedure above, Ice-detecting sensor is **abnormal**.
※ ETY = empty

13-3-3 Icemaker not making ice or not making enough ice (Other Suspected Items)

Strongly suspect items below If the issue remains yet, though all the diagnosis for icemaker has been carried out.

- Cap duct bad sealing
- Defective thermal sensor in the icemaker compartment
- Not cold icemaker compartment area (sealed system)

13-3-4 Not Dispensing Ice

► Clogged Ice In the Ice Bin (suspected items)

- Customer haven't used ice dispenser over a week.
→ **Resolution** : the ices gets stuck if customer doesn't use ice dispenser.
In this case, empty the ice bin and wait until the new ices are stacked in the ice bin.
- Temperature of icemaker compartment is not cold enough.
→ **Resolution** : Check ice fan, sealed system, cap duct, vent and other items related to temperature.
- Cap duct doesn't seal the air properly.
→ **Resolution** : Possibly, warm air could get into the compartment and make ices get stuck. Replace the cap duct with new one.
- In-door geared motor doesn't work
→ **Resolution** : Change the in-door geared motor and test it.
- The water comes out of fill cup and the water get into the ice bin.
→ **Resolution** : The water pressure from shutoff valve is too high.
Recommend to use regulator to the customer and close the shutoff valve slightly.

► Clogged Ices In the Chute (suspected items)

- Cap duct doesn't seal the air properly.
→ **Resolution** : Possibly, warm air could get into the compartment and make ices get stuck. Replace the cap duct with new one.

14. DESCRIPTION OF FUNCTION & CIRCUIT OF MICOM

14-1 FUNCTION

14-1-1 Function

1. When the appliance is plugged in, it is set to 37°F for Refrigerator and 0°F for freezer.
You can adjust the Refrigerator and the Freezer control temperature by pressing the ADJUST button.
2. When the power is initially applied or restored after a power failure, it is set to Control temperature Previously.
3. If you do not press any button after turning on the power, only CRUSH or CUBE Label that has been selected will be turned on and all other LEDs on the display Panel will be turned off within 60 seconds. (Power Save Mode)
4. If you press a button, only CRUSH, CUBE label and Lock icon that has been selected will be turned on and all other LEDs on the display Panel will be turned off within 20 seconds. (Power Save Mode)

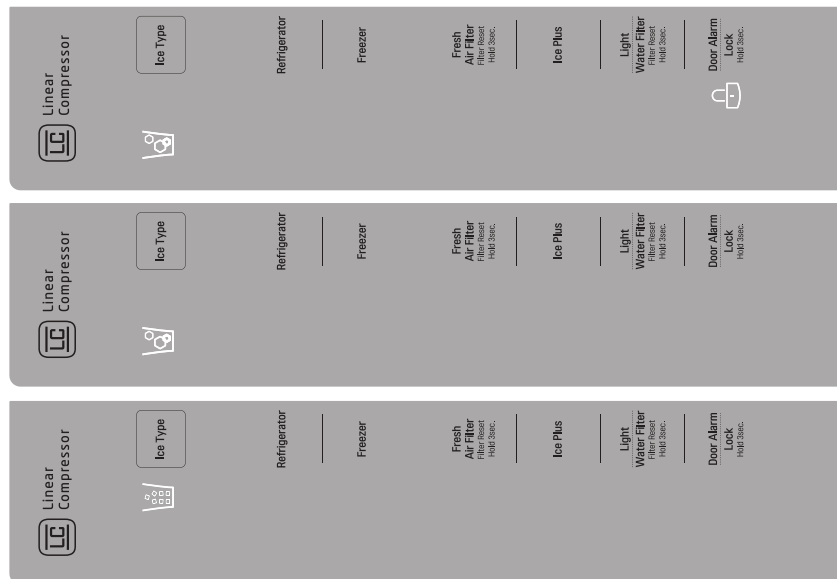

14-1-2 How to Toggle the Display between °F & °C

1. The initial setting is °F and the display temperature mode can be changed from °F to °C or °C to °F by pressing and holding the FRZ TEMP and the REF TEMP keys at the same time for over 5 seconds.

14-1-3 Lock function (dispenser and display button lock)

1. When the refrigerator is first turned on, the buttons are not locked. "LOCK" is deactivated with no light on.
2. To lock the display, the dispenser, and the control panel, press and hold the LOCK button for 3 seconds. "LOCK" is activated with "Lock Icon" on.
3. The LOCK button is the only control feature that remains active in the locked state. The buzzer sound, other control buttons, and the dispenser are deactivated.
4. To release from the locked state, press and hold the LOCK button again for 3 seconds.
5. If you don't hold the Alarm/Lock button more than 3 seconds, Alarm function will be changed and alarm for opened door will be on/off same as alarm icon indicating.





Ex) In selecting
"LOCK"

Ex) In selecting
"LOCK" again

14-1-4 Filter condition display function

1. There is a replacement indicator light for the filter cartridge on the dispenser.
2. Water filter needs replacement once six months or of using water filter.
3. When the Water Filter Icon blinks, you must exchange the filter.
4. After replacing the filter, press and hold the Light/Filter button for more than 3 seconds.
After then water Filter icon turn off with reset status.

Classification	In initial Power On / Filter RESET	Blinking
Filter Status Display		

14-1-5 Air Filter selection

Please select this function for Air Filter.

- When you press the Air Filter Button, the "POWER" will be turned on again.
- Air Filter POWER function automatically turns off after a fixed time passes.

14-1-6 Ice Plus selection

1. Please select ice plus function for quick freezing.
2. When you press the ice plus button, the ice plus icon will be turned on again.
3. Ice plus function automatically turns off after a fixed time passes.



14-1-7 Dispenser use selection

You can select water or ice by separated pad switch.

- When you press ice type button, ice type will be changed. (Crush or Cube)
- Hold your cup in the dispenser for a few seconds after dispensing ice or water to allow the last pieces of ice drops of water to fall into the cup.
- When after initially establishing the water comes out, the water tank inside fills and until at the time of quality the hour is caught.



14-1-8 CONTROL OF FREEZER FAN MOTOR

1. Freezer fan motor has high and standard speeds.
2. High speed is used at power-up, for Ultra Ice, and when refrigerator is overloaded.
Standard speeds is used for general purposes.
3. To improve cooling speed, the RPM of the freezer fan motor change from normal speed to high.
4. High speed (2700RPM) : Initial power on or load corresponding operation, Ultra Ice.
Normal speed (2400RPM) : General working conditions.

14-1-9 Cooling Fan Motor

1. The cooling fan is switched ON and OFF in conjunction with the compressor.
2. The cooling fan Motor has high and standard speeds. (When room temperature more high than 38°C speed is high)
3. The Failure sensing method is the same as in the fan motor of the freezing fan motor (refer to failure diagnosis function table for failure display).

14-1-10 Ice Compartment Fan

1. The Icing Fan is controlled by the the sensor on the top of the ice compartment.
2. The Failure sensing method is the same as in the fan motor of the freezer (refer to failure diagnosis function table for failure display)

14-1-11 Refrigeration room Fan Motor

1. The refrigeration room fan is switched ON and OFF in conjunction with the refrigeration room temperature.
2. The Failure sensing method is the same as in the fan motor of the freezing fan motor (refer to failure diagnosis function table for failure display).

14-1-12 Ice PLUS

1. The purpose of this function is to intensify the cooling speed of freezer and to increase the amount of ice.
2. Whenever selection switch is pressed, selection/release, the Icon will turn ON or OFF.
3. If there is a power outage and the refrigerator is powered on again, Ice PLUS will be canceled.
4. To activate this function, press the Ice PLUS key and the Icon will turn ON. This function will remain activated for 24 hrs. The first one hour the compressor, Freezer Fan and Icing Fan will be ON. The next 23 hours the Ice room will be controlled at the lowest temperature. After 24 hours or if the Ice PLUS key is pressed again, the Ice room will return to its previous temperature.
5. During the first hour :
 - (1) Compressor, Freezer Fan and Icing Fan run continuously.
 - (2) If a defrost cycle begins during the first 30 minutes of Ice Plus, the Ice PLUS cycle will complete its cycle after defrosting has ended.
If the defrost cycle begins when Ice Plus has run for more than 30 minutes, Ice PLUS will run for 40 minutes after the defrost is completed.
 - (3) If Ice PLUS is pressed during defrost, Ice Plus Icon is on but this function will start seven minutes after defrost is completed and it shall operate for three hours.
 - (4) If Ice Plus is selected within seven minutes after compressor has stopped, the compressor (compressor delays seven minutes) shall start after the balance of the delay time.
6. For the rest of the 23 hours, the Ice room will be controlled at the lowest temperature.

14-1-13 How to set the display mode and cancel it

1. With the refrigerator door open, keep pressing the Refrigerator Temp Button and ICE PLUS Button more than 5 seconds, then it goes to the display mode with Special Beep Sound With Special Beep Sound.
2. Perform the same way again to cancel the display mode.
3. All Freezing unit will be turned off at display mode (Exceptions : Lamp, Display)

14-1-14 Defrosting (removing frost)

1. Defrosting starts each time the COMPRESSOR running time Between 7~50 hours.
2. For initial power on or for restoring power, defrosting starts when the compressor running time reaches 4 hours.
3. Defrosting stops if the sensor temperature reaches 46.4°F(8°C) or more. If the sensor doesn't reach 46.4°F(8°C) in 1 hours, the defrost mode is malfunctioning. (Refer to the defect diagnosis function, 8-1-15.)
4. Defrosting won't function if its sensor is defective (wires are cut or short circuited)

14-1-15 Defect Diagnosis Function

1. Automatic diagnosis makes servicing the refrigerator easy.
2. When a defect occurs, the buttons will not operate; but the tones. such as ding. will sound.
3. When the defect CODE removes the sign, it returns to normal operation (RESET).
4. The defect CODE shows on the Refrigerator and Freezer Display.



- * Display check function: If simultaneously pressing Ultra Ice button and freezing temperature adjustment button for a second, display LCD graphics on. If releasing the button, the LCD graphic displays the previous status.
You can check the error code Within 3-hour Period from initial error

15. EXPLODED VIEW & REPLACEMENT PARTS LIST

CASE PARTS

CAUTION : Use the part number to order part, not the position number.

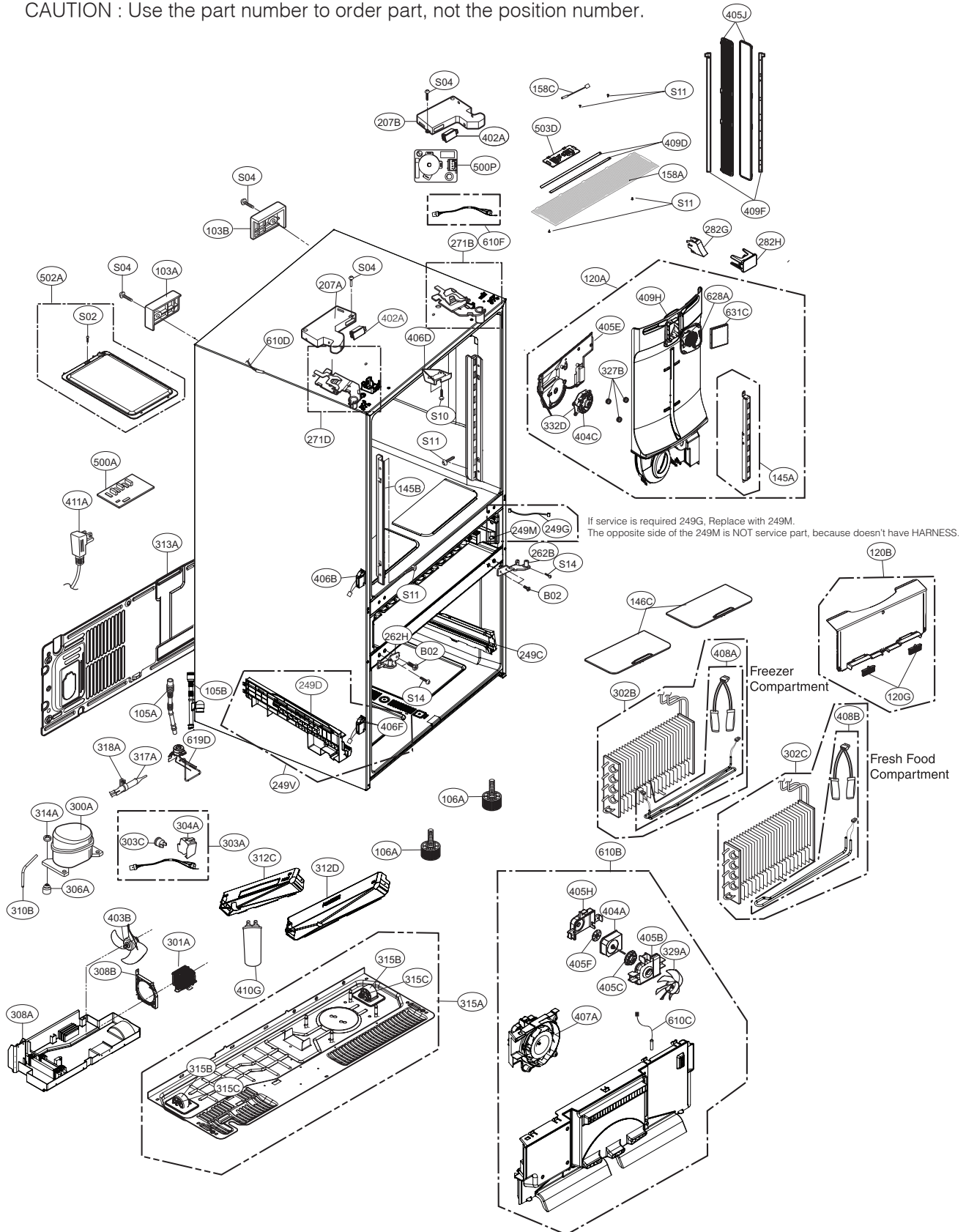

CUSTOMCHILL PARTS

CAUTION : Use the part number to order part, not the position number.

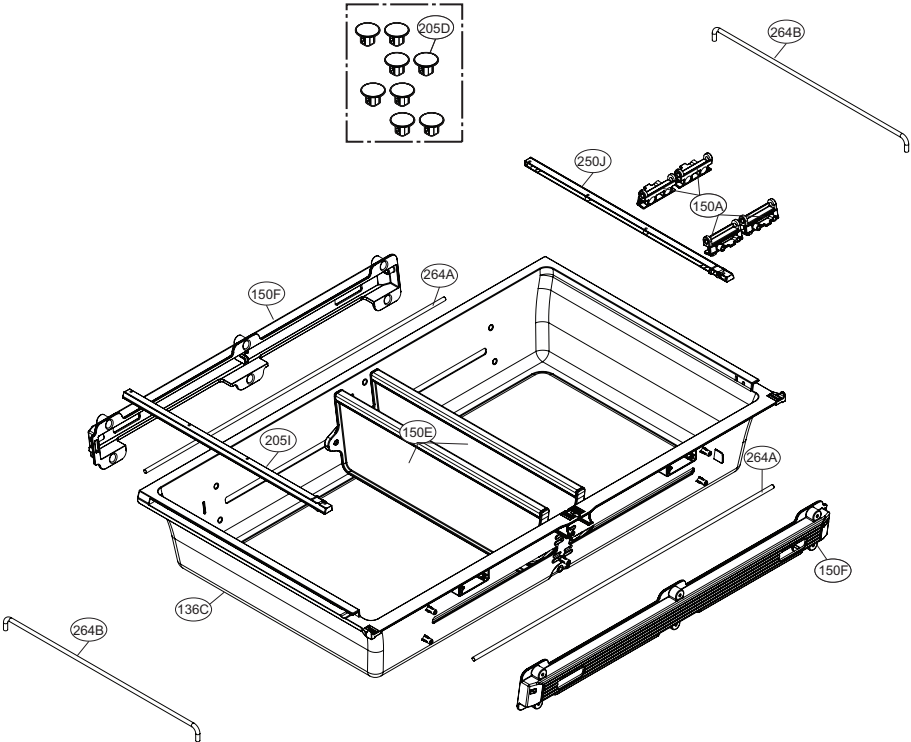

FREEZER PARTS

CAUTION : Use the part number to order part, not the position number.

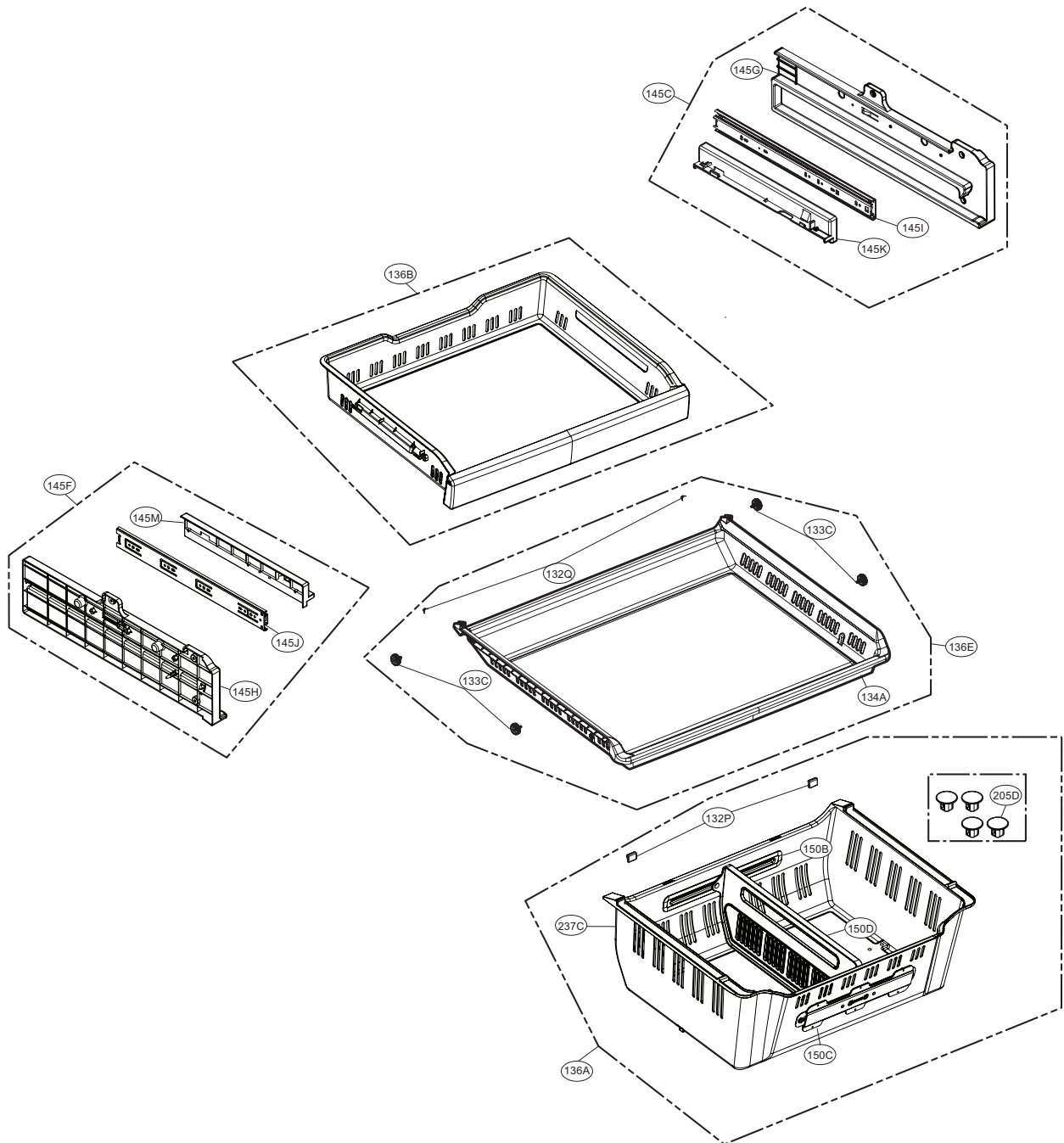

REFRIGERATOR PARTS

CAUTION : Use the part number to order part, not the position number.

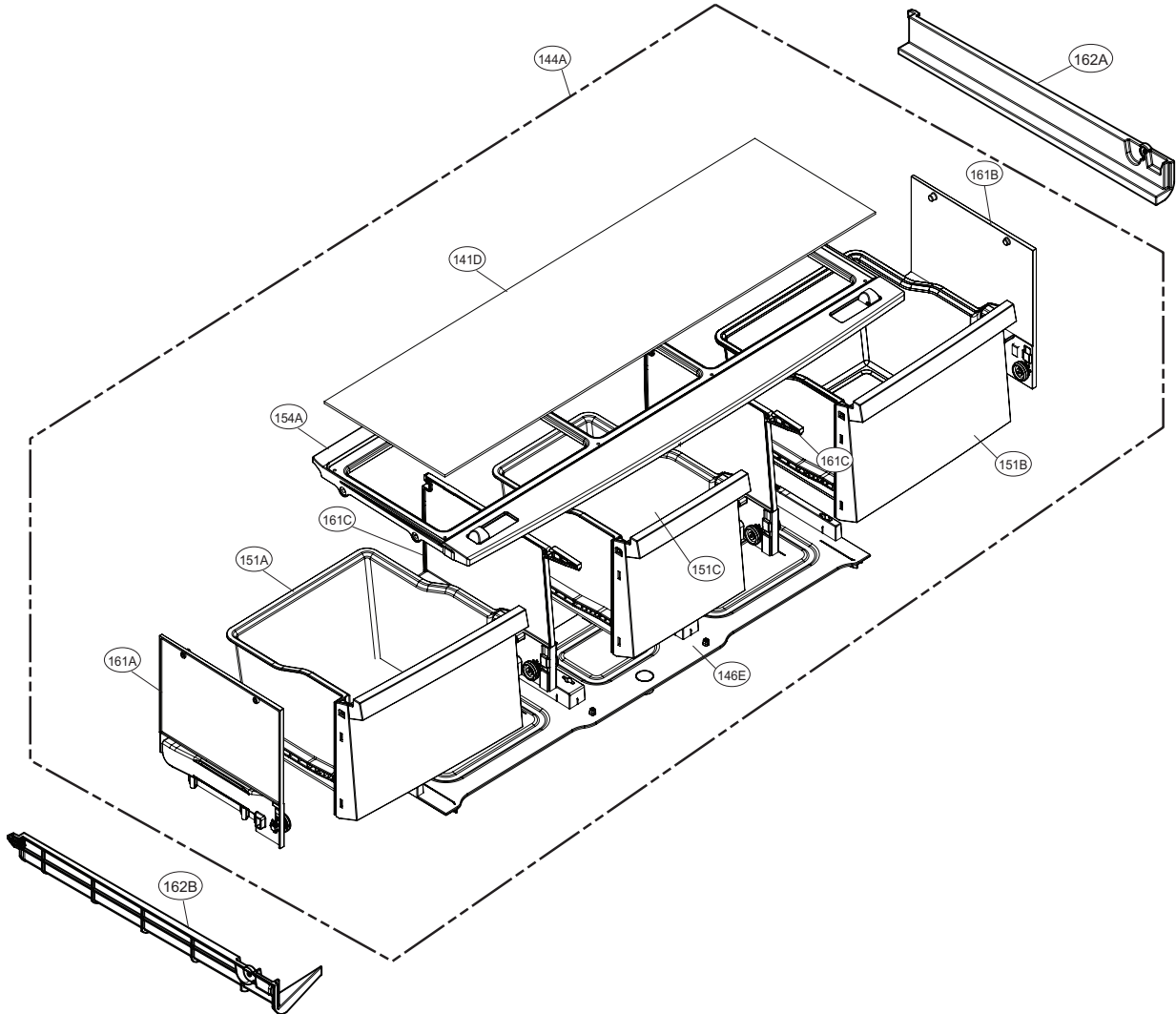
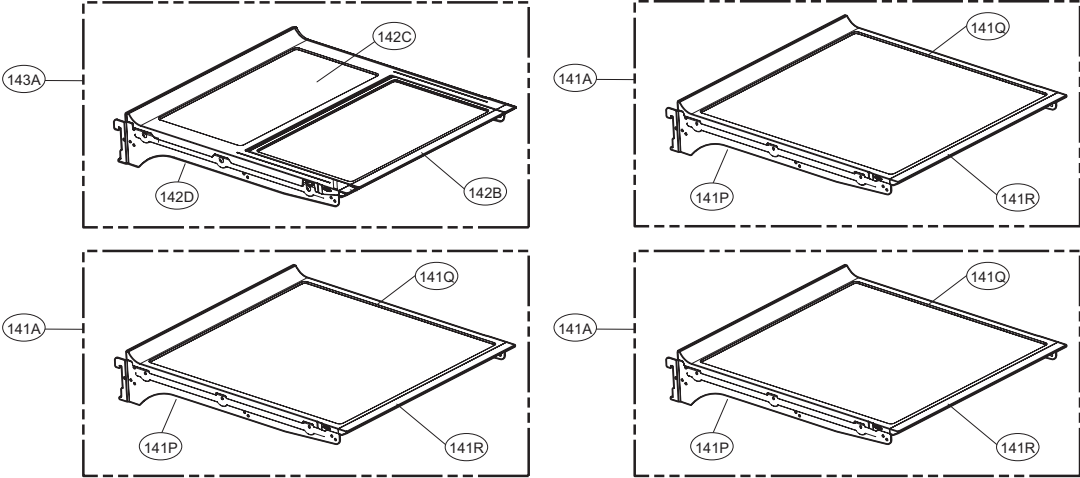

DOOR PARTS

CAUTION : Use the part number to order part, not the position number.

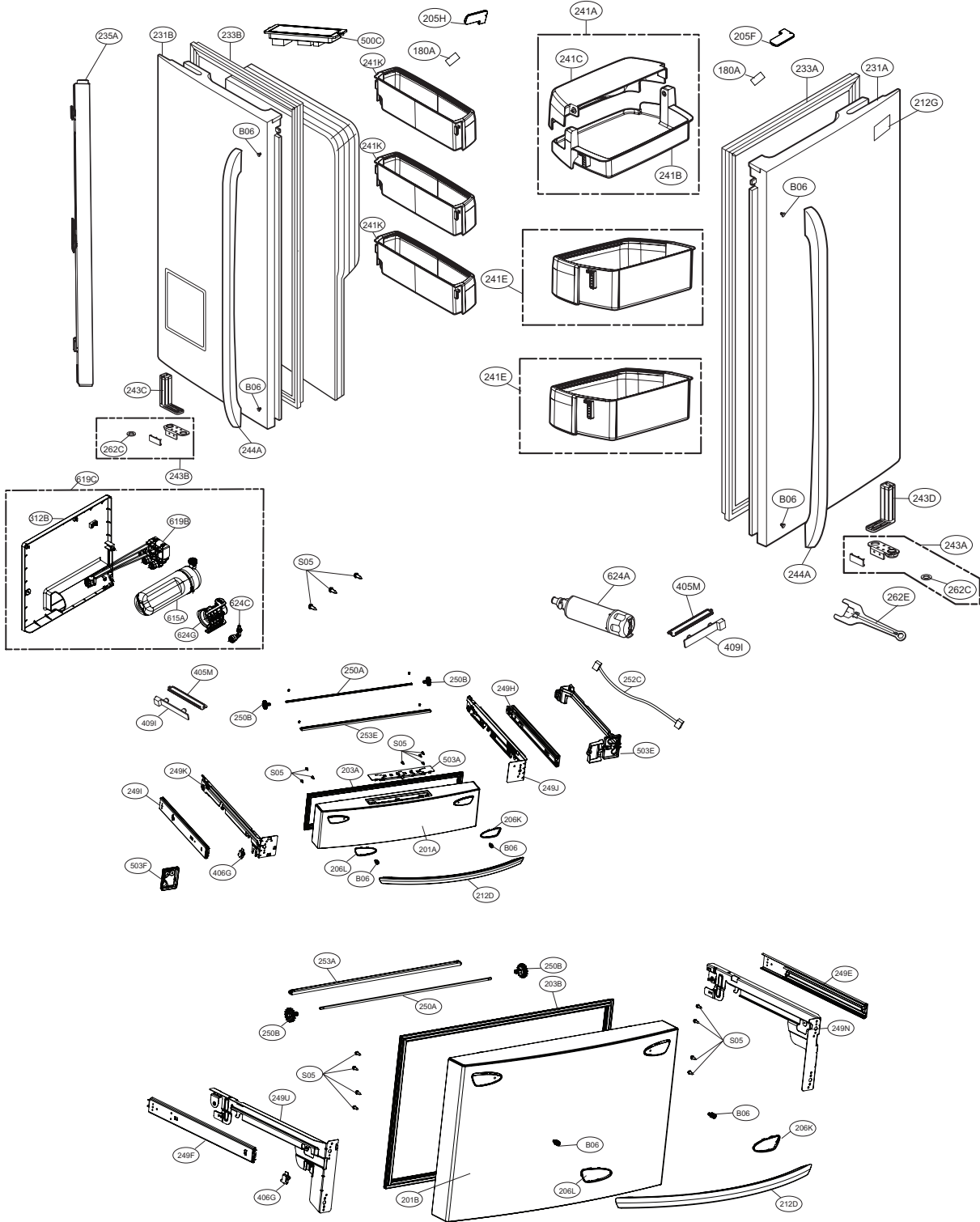

DISPENSER PARTS

CAUTION : Use the part number to order part, not the position number.

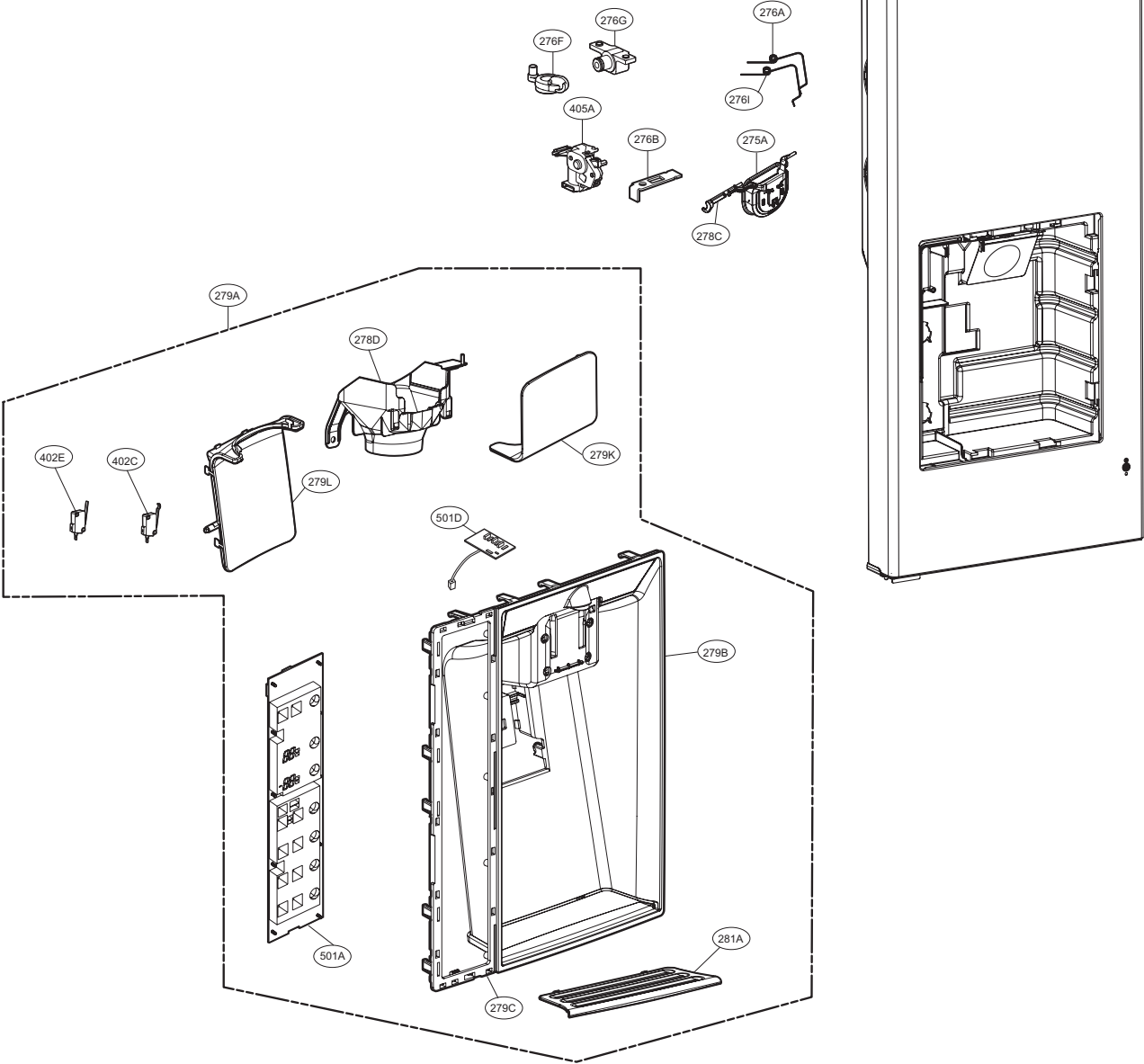

VALVE & WATER TUBE PARTS

CAUTION : Use the part number to order part, not the position number.

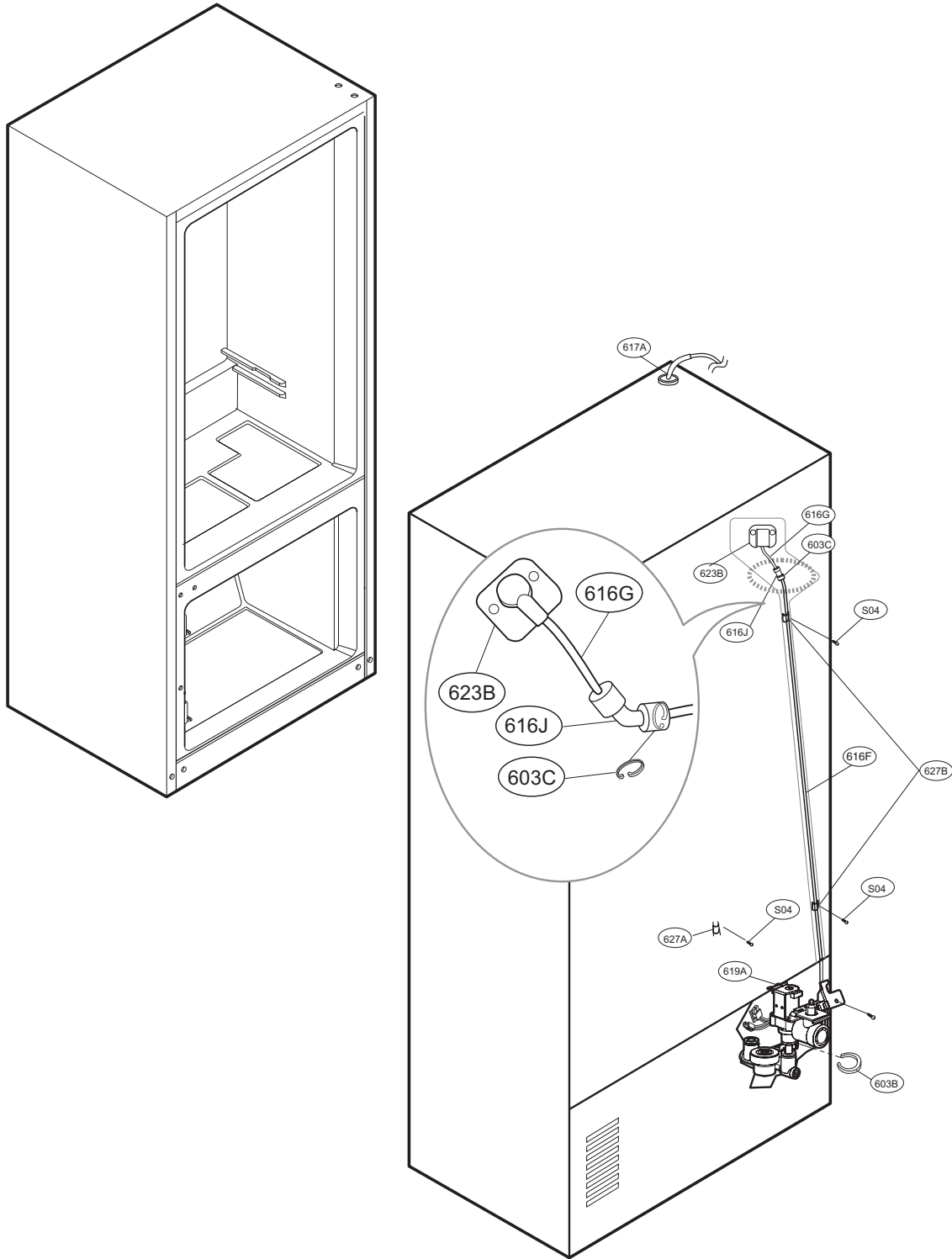

ICE MAKER & ICE BIN PARTS

CAUTION : Use the part number to order part, not the position number.

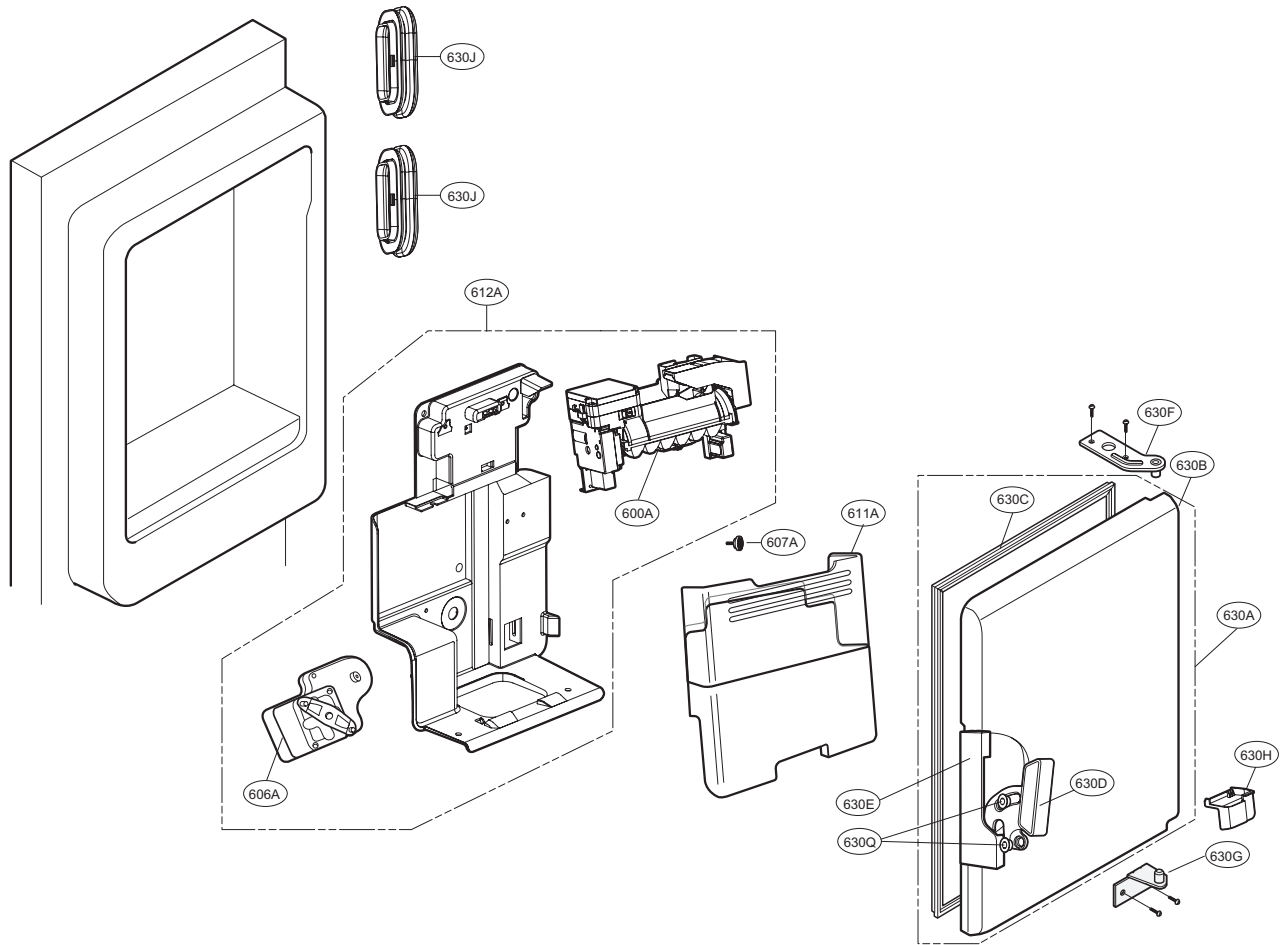



LG Electronics Inc.

P/No. MFL62188128

SEP., 2014 Printed in Korea