



Internal Use Only



MICROWAVE OVEN **SERVICE MANUAL**

**MODEL: LMV2031ST
LMV2031SB
LMV2031SW
LMV2031BD**

CAUTION

BEFORE SERVICING THE UNIT, READ THE SAFETY PRECAUTIONS IN THIS MANUAL.

P/NO : MFL06272533

January, 2014
Printed in Korea

CAUTION

WARNING TO SERVICE TECHNICIANS

PRECAUTIONS TO BE OBSERVED BEFORE AND DURING SERVICING TO AVOID POSSIBLE EXPOSURE TO EXCESSIVE MICROWAVE ENERGY

- a. Do not operate or allow the oven to be operated with the door open.**
- b. Make the following safety checks on all ovens to be serviced before activating the magnetron or other microwave source, and make repairs as necessary; (1) Interlock operation, (2) proper door closing, (3) seal and sealing surfaces (arcing, wear, and other damage), (4) damage to or loosening of hinges and latches, (5) evidence of dropping or abuse.**
- c. Before turning on microwave power for any service test or inspection within the microwave generating compartments, check the magnetron, wave guide or transmission line, and cavity for proper alignment, integrity, and connections.**
- d. Any defective or misadjusted components in the interlock, monitor, door seal, and microwave generation and transmission systems shall be repaired, replaced, or adjusted by procedures described in this manual before the oven is released to the owner.**
- e. A microwave leakage check to verify compliance with the federal performance standard should be performed on each oven prior to release to the owner.**
 - Proper operation of the microwave oven requires that the magnetron be assembled to the wave guide and cavity. Never operate the magnetron unless it is properly installed.
 - Be sure that the magnetron gasket is properly installed around the dome of the tube whenever installing the magnetron.
 - Routine service safety procedures should be exercised at all times.
 - Untrained personnel should not attempt service without a thorough review of the test procedures and safety information contained in this manual.

FOREWORD

Read this manual carefully. Failure to adhere to or observe the information in this manual may result in exposing yourself to the microwave energy normally contained within the oven cavity.

CONTENTS

(Page)

Safety Precautions	2
1. Specifications	4
2. Cautions	5
3. Installation	6
4. Operation	7
4-1. Control Panel Features	7
4-2. Explanation of Control Panel.....	8
5. Wiring Diagram / Key Matrix	9
5-1. Wiring Diagram	9
5-2. Key Matrix	10
6. Troubleshooting	11
6-1. General Information for Service	11
6-2. Safety Caution.....	12
6-3. Basic Check Summary.....	13
6-4. Troubleshooting	14
7. Microwave Leakage Test	24
8. Power Output Measurement	26
9. Interlock System	27
9-1. Interlock Mechanism	27
9-2. Interlock Continuity Test.....	29
10. Component Testing Information	30
11. Disassembly Instructions	34
12. Exploded View	40

1. SPECIFICATIONS

Rated Power Consumption	1600W maximum (Microwave oven+Cook top lamps+Ventilation fan)
Microwave Output	1000W (IEC60705)
Frequency	2450 MHz ±50 MHz
Power Supply	120 VAC, 60 Hz
Rated Current	14 Amp. (Microwave oven+Cook top lamps+Ventilation fan)
Magnetron Cooling	Forced Air Cooling
Rectification	Rectification Voltage Double Half-Wave
Door Sealing	Choke System
Safety Devices	OVEN TCO 110/0 MGT TCO 180/60 Bottom TCO : 145/0 Fuse (20A) Primary Interlock Switch Secondary Interlock Switch Interlock Monitor Switch
Magnetron	2M246 - 050GP
Cook Top Lamp	Halogen lamp ,130V,50W
Cavity Lamp	125 V, 30 W or 40 W
Timer	Digital, up to 99 min. 99 sec. (in each cooking stage)
Tray	Tempered Safety Glass
Overall Dimensions	29 ^{14/16} " (W) x 16 ^{7/16} " (H) x 15 ^{13/16} " (D)
Oven Cavity Size	22 (W) x 11 ^{5/8} " (H) x 14 ^{5/8} " (D)
Effective Capacity of Oven Cavity	2.0Cu.ft.
Accessories	Owner's Manual & Cooking Guide, Installation Manual, Exhaust Adapter, Exhaust Damper, Mounting Kit and Filter, Glass Tray, Metal Rack, Rotating Ring Assembly.

SWITCH CHART

SWITCH MODE	PRIMARY INTERLOCK SWITCH	SECONDARY INTERLOCK SWITCH	INTERLOCK MONITOR SWITCH
CONDITIONS	COM NO	COM NO	COM NC
DOOR OPEN	OPEN	OPEN	CLOSE
DOOR CLOSED	CLOSE	CLOSE	OPEN

NOTE: Use the above switch chart with circuit diagram on page 5-1.

2. CAUTIONS

Unlike other appliances, the microwave oven is high-voltage and high-current equipment. Though it is free from danger in ordinary use, extreme care should be taken during repair.

- DO NOT operate on a 2-wire extension cord during repair and use.
- NEVER TOUCH any oven components or wiring during operation.
- BEFORE TOUCHING any parts of the oven, always remove the power plug from the outlet.
- Remove your watches whenever working close to or replacing the magnetron.
- DO NOT touch any parts of the control panel circuit. A resulting static electric discharge may damage the P.C.B.
- NEVER operate the oven with no load.
- NEVER injure the door seal and front plate of the oven cavity.
- NEVER put iron tools on the magnetron.
- NEVER put anything into the latch hole and the interlock switches area.

MICROWAVE RADIATION

Personnel should not be exposed to the microwave energy which may radiate from the magnetron or other microwave generating device if it is improperly used or connected. All input and output microwave connections, waveguide, flange, and gasket must be secure. Never operate the device without a microwave energy absorbing load attached. Never look into an open waveguide or antenna while the device is energized.

- Proper operation of the microwave oven requires that the magnetron be assembled to the waveguide and cavity. Never operate the magnetron unless it is properly installed.
- **Be sure that the magnetron gasket is properly installed around the dome of the tube whenever installing the magnetron.**

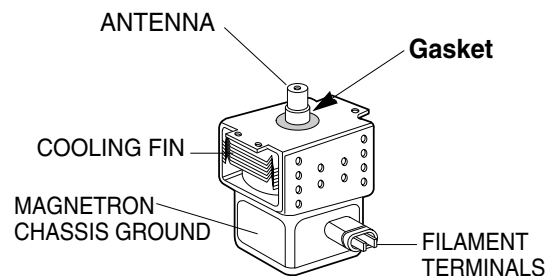

MAGNETRON

THE OVEN IS TO BE SERVICED ONLY BY PROPERLY QUALIFIED SERVICE PERSONNEL.

3. INSTALLATION

BEFORE YOU BEGIN, READ THE FOLLOWING INSTRUCTIONS COMPLETELY AND CAREFULLY.

PRECAUTIONS ON INSTALLATION

- A. Plug the power supply cord into a 120V AC, 60Hz, single-phase power source with a capacity of at least 20 amperes.
- B. Avoid placing the unit in a location where there is direct heat or splashing water.
- C. Install the unit on the mounting plate firmly.
- D. Place the unit as far away as possible from TV, radio, etc. to prevent interference.

GROUNDING INSTRUCTIONS

For personal safety, this appliance must be fully grounded at all times.

In the event of an electrical short circuit, grounding reduces the risk of electric shock.

The plug must be plugged into an outlet that is properly installed and grounded.

CAUTION

This unit is equipped with a 3-prong plug for your safety. If the wall outlet is a grounded 3-hole type, the unit will be grounded automatically.

Plug with Ground Prong

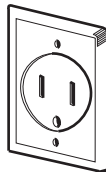
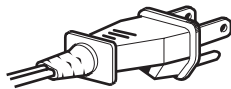

Properly Polarized and Grounded Outlet

WARNING

Improper use of the grounding plug can result in a risk of electric shock.

Do not, under any circumstances, cut or remove the third ground prong from the power cord plug.

4. OPERATION

4-1. Control Panel

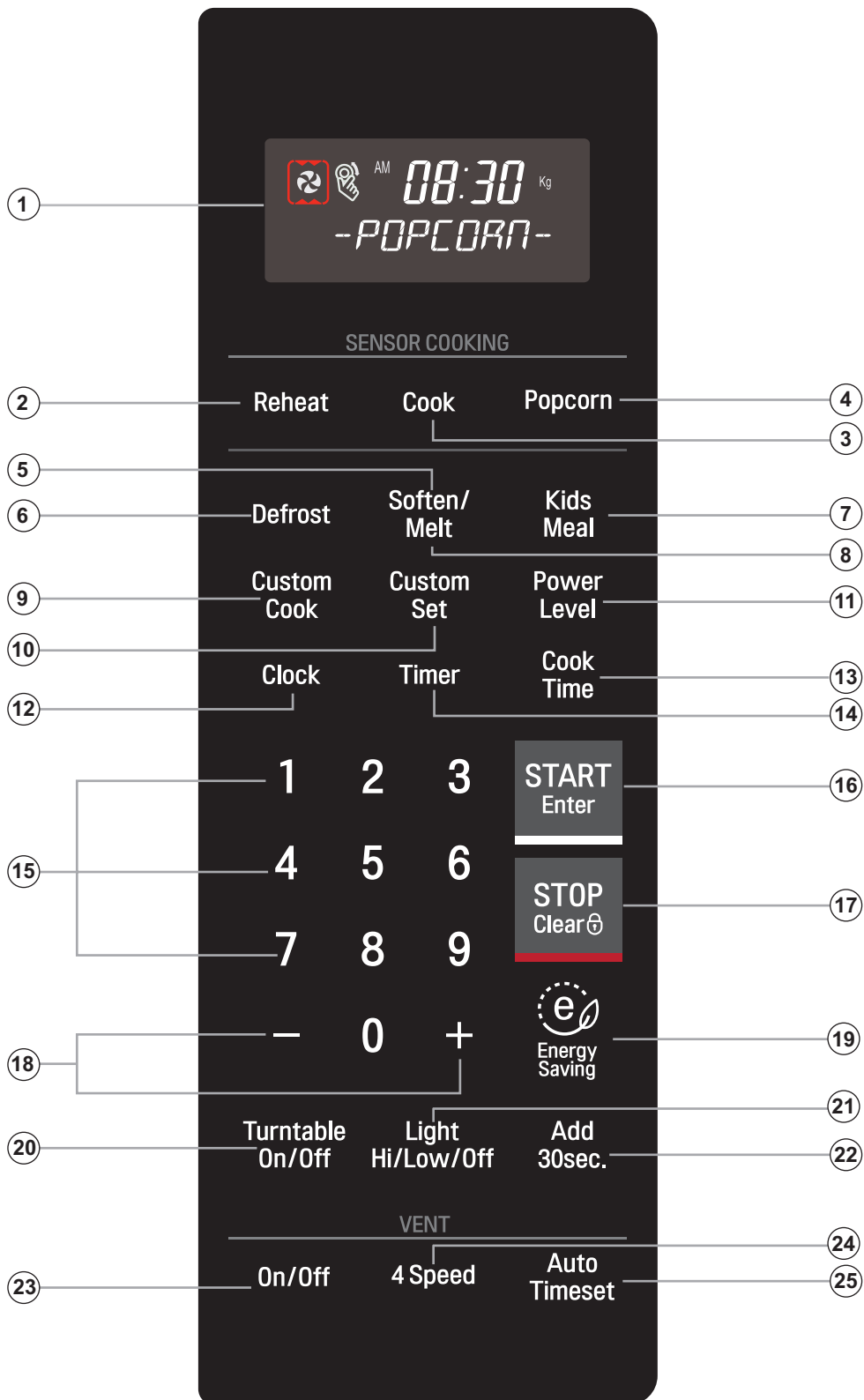

4-2. Explanation of Control Panel

1. **DISPLAY** The Display includes a clock and indicators to tell you the time of day, cooking time settings and cooking functions selected.
2. **AUTO REHEAT** Press this button to reheat dinner plate, soup/sauce, casserole, roll/muffin.
3. **AUTO COOK** Press this button to cook fresh vegetables, frozen vegetables, rice, or casseroles.
4. **POPCORN** Press this button when popping popcorn in your microwave oven.
5. **SOFTEN** Press this button to soften butter, ice cream, cream cheese, or frozen juice.
6. **DEFROST** Touch this button to defrost frozen food.
7. **KIDS MEAL** Select type of dish to reheat HOT DOG, MAC & CHEESE or CHICKEN NUGGETS.
8. **MELT** Press this button to melt butter or margarine, chocolate, cheese, or marshmallows.
9. **CUSTOM COOK** Touch this button to make oven remember Cook time and Power level.
10. **CUSTOM SET** Touch this pad to change the oven's default setting for sound, clock, display speed, and defrost weight.
11. **POWER LEVEL** Press this button to select a cooking power level.
12. **CLOCK** Press this button to enter the time of day.
13. **COOK TIME** Press this button to set a cooking time.
14. **TIMER**
15. **NUMBER** Press this button to enter cooking time, power level, quantities or weights.
16. **START/ENTER** Press this button to start a function. If you open the door after oven begins to cook, press START/ENTER again.
17. **STOP/CLEAR** Press this button to stop the oven or clear all entries.
18. **+, -** Touch this button to add or subtract ten seconds of cooking time each time you touch it.
19. **ENERGY SAVING** Press this button to save energy.
20. **TURNTABLE ON/OFF**
21. **LIGHT HIGH/LOW/OFF** Touch this button to turn the cooktop/couertop light on high/low or off.
22. **ADD 30 SEC** Press this button to control the add 30sec. cook time.
23. **VENT ON/OFF** Touch button to turn the vent on slow or off.
24. **VENT 4 SPEED** Touch button to change vent speed.
25. **VENT AUTO TIMESET** Vent Auto Timeset Touch this button to set ventilation time. (1, 3, 5, 10, and 30 minutes.)

5. WIRING DIAGRAM / KEY MATRIX

5-1. Wiring Diagram

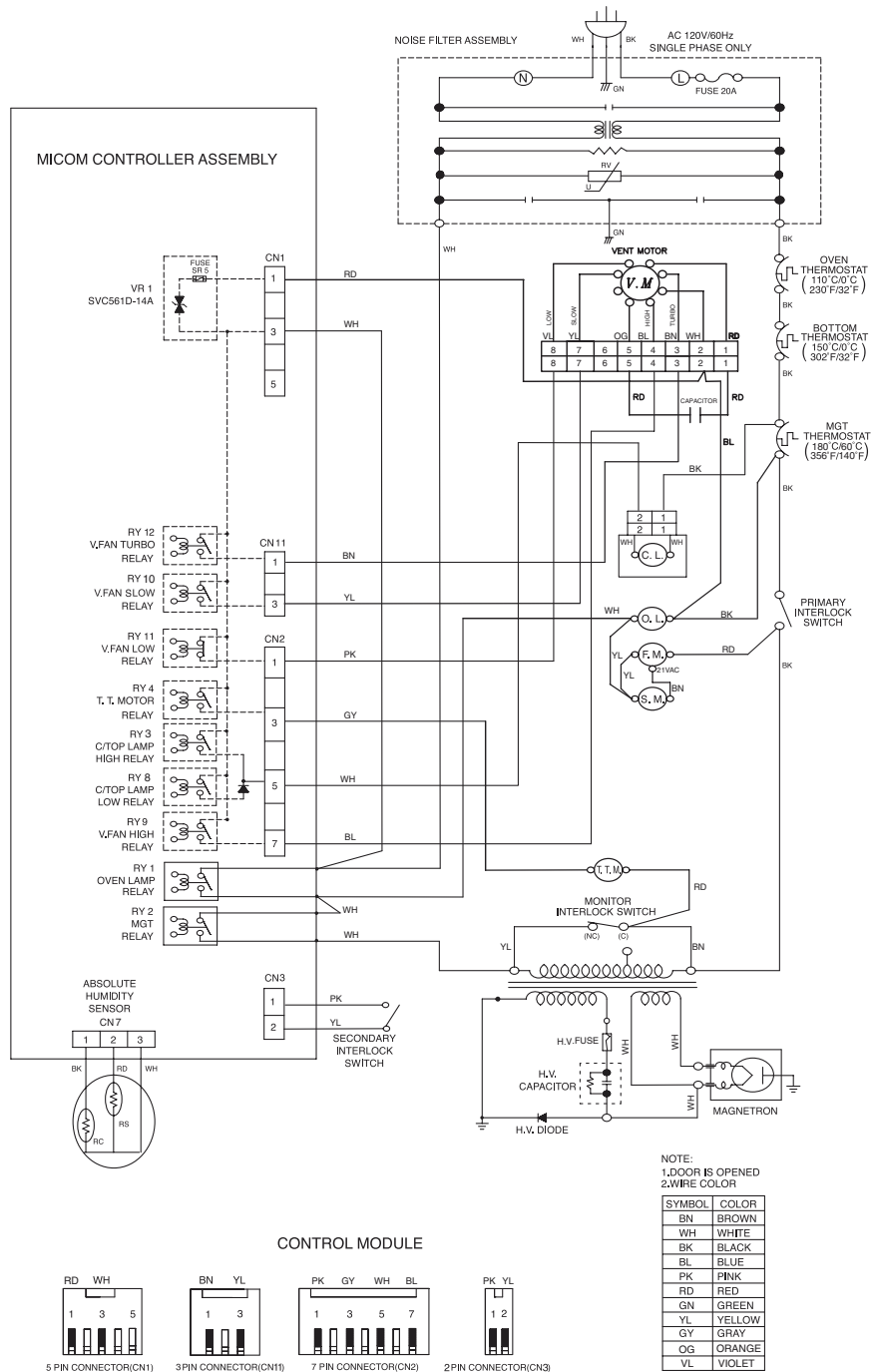

5-2. Key Matrix

KEY MATRIX

2st	1	2	3	4	5	6	7
8							
9	Clear	Vent Hi/Low/Off	Clock	Energy Saving	Add 30 Sec.	Quick Defrost	Soften
10	1	2	3	4	5	6	Melt
11	7	8	9	0	Timer	Sensor Reheat	Less
12	Sensor Popcorn	N.A	N.A	time & weight Defrost	Sensor Cook	N.A	More
13	Start	C/T Lamp On/Off	Hold Warm	N.A	Time Cook	Power Level	Turntable On/Off

6. TROUBLESHOOTING

6-1. General Information for Service

GENERAL PRECAUTIONS IN USE

- A. Never operate the unit when it is empty.
Operating the oven with no load may shorten the life of the magnetron. Whenever cooking dry foods (dried fish, bread, etc.) or a small amount of food, be sure to put a glass of water into the cooking compartment. The glass turntable may become hot after operating, be careful when touching it.
- B. Aluminum foil should be avoided because it will disrupt cooking and may cause arcing. However, small pieces may be used to cover some parts of food to slow the cooking. Any aluminum foil used should never be closer than 1 in. (2.5 cm) to any side wall of the oven.

TRIAL OPERATION

After installation, the following sequences and results should be checked carefully.

- A. Put a container filled with water (about 1 liter) into the oven, and close the door tightly.
- B. Set cooking time for 10 minutes by touching 1 and then 0 three times. 1, 0, 0, 0 appears in the display window.
- C. Press the **START** button
Make sure the cavity light comes on. The unit will begin cooking and the display window will show the time counting down by seconds.
- D. After about 5 minutes, make sure the primary interlock switch, the secondary interlock switch and the interlock monitor switch operate properly by opening and closing the door several times. Press the **START** button each time the door is closed.
- E. Continue operating the unit. Two short beeps and one long beep will sound when the time is up. The unit will shut off automatically.
- F. Confirm the water is hot.
- G. Finally, measure the output power according to the **POWER OUTPUT MEASUREMENT** on page 8.

FEATURES AND SPECIFICATIONS

FEATURES

- A. The safety systems incorporated in this model are:
 - (1) Primary interlock switch
 - (2) Secondary interlock switch
 - (3) Interlock monitor switch
 - (4) Choke system
 - (5) Oven cavity thermostat
(Note This thermostat located on the oven cavity will open and stop the unit from operation only if a high temperature is reached, such as, a fire created by overcooking food.)
- B. Any one of 10 power output levels ranging 0 W to 1,000 W can be selected by the touch control and electronic computer system.
- C. Cooking time can be displayed on the digital readout.
- D. Three different cooking stages (including defrost) can proceed from one cooking stage to another. This is made possible with the memory function of the microprocessor.

6-2. Safety Caution

A. SINCE NEARLY 4,000 VOLTS EXISTS IN SOME CIRCUITS OF THIS UNIT REPAIRS SHOULD BE CARRIED OUT WITH GREAT CARE.

The filament leads of the magnetron carry High Voltage with respect to the ground. Extreme caution must be exercised. Never plug the unit into a power source to determine which component is defective in the high voltage section.

B. TO AVOID POSSIBLE EXPOSURE TO MICROWAVE ENERGY LEAKAGE, THE FOLLOWING PRECAUTIONS MUST BE TAKEN BEFORE SERVICING.

- (1) Before the power is applied:
 - (a) Make sure the primary interlock switch, the secondary interlock switch and the interlock monitor switch operate properly by opening and closing the door several times.
 - (b) Make sure the perforated screen and the dielectric choke of the door are correctly and firmly mounted.
- (2) After power is applied:
 - (a) Make sure the interlock switch mechanism is operating properly by opening and closing the door.
 - (b) Check microwave energy leakage must be below the limit of 5 mW/cm² .
(All service adjustments should be made for minimum microwave energy leakage readings).
- (3) Do not operate the unit until it is completely repaired. If any of the following conditions exist, the unit must not be operated.
 - (a) The door does not close firmly.
 - (b) The hinge is broken.
 - (c) The door seal is damaged.
 - (d) The door is bent or warped, or there is any other visible damage on the unit that may cause microwave energy leakage.

NOTE: Always keep the seal clean.

 - (e) Make sure that there are no defective parts in the interlock mechanism.
 - (f) Make sure that there are no defective parts in the microwave generating and transmission assembly (especially waveguide).
- (4) The following items should be checked after the unit is repaired:
 - (a) The interlock monitor switch is connected correctly and firmly.
 - (b) The magnetron gasket is properly positioned and mounted.
 - (c) The waveguide and the oven cavity are intact. (no microwave energy leakage)
 - (d) The door can be properly closed and the safety switches work properly.
 - (e) The unit must stop when the door is opened or the time is up.

The unit must not be operated with any of the above components removed or bypassed.

6-3 Self diagnosis (humidity Sensor and PCB thermistor check) & Error code

1. Press "Defrost weight/time" for 2 seconds , unit will display "TEST" and Beep once;

Error code	Symptom
F-1	PCB thermistor short
F-2	PCB thermistor open
F-4	Humidity sensor open or short

2. The unit will check if the PCB humidity sensor and PCB thermistor are short or open.

3. If it has an error, it will beep and display an error code.

4. If the unit is normal , it will beep and display "PASS".

5. Press " Clear" to return to Standby mode.

6-3. Basic Check Summary

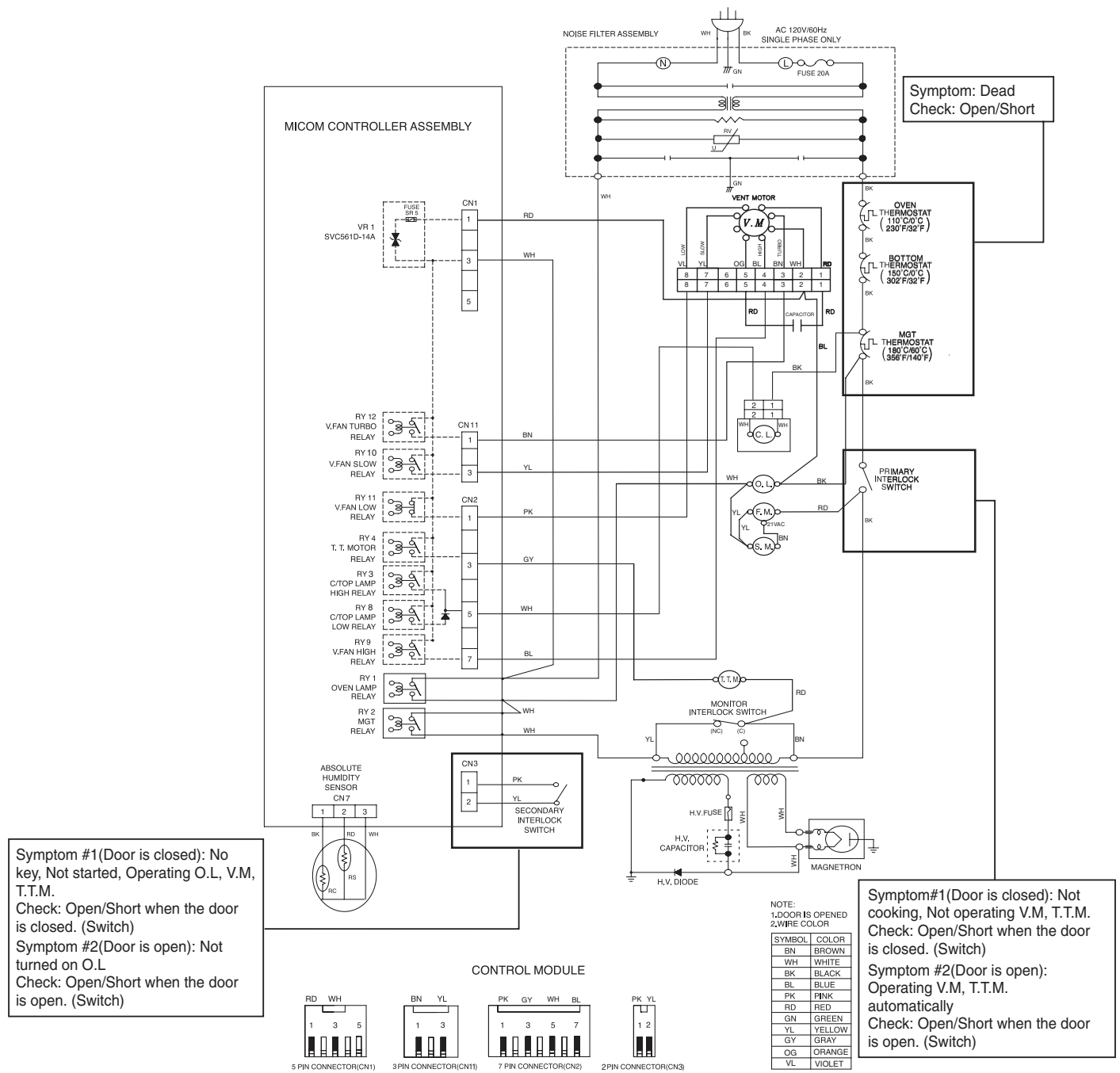

6-4. Troubleshooting

No Display or Dead

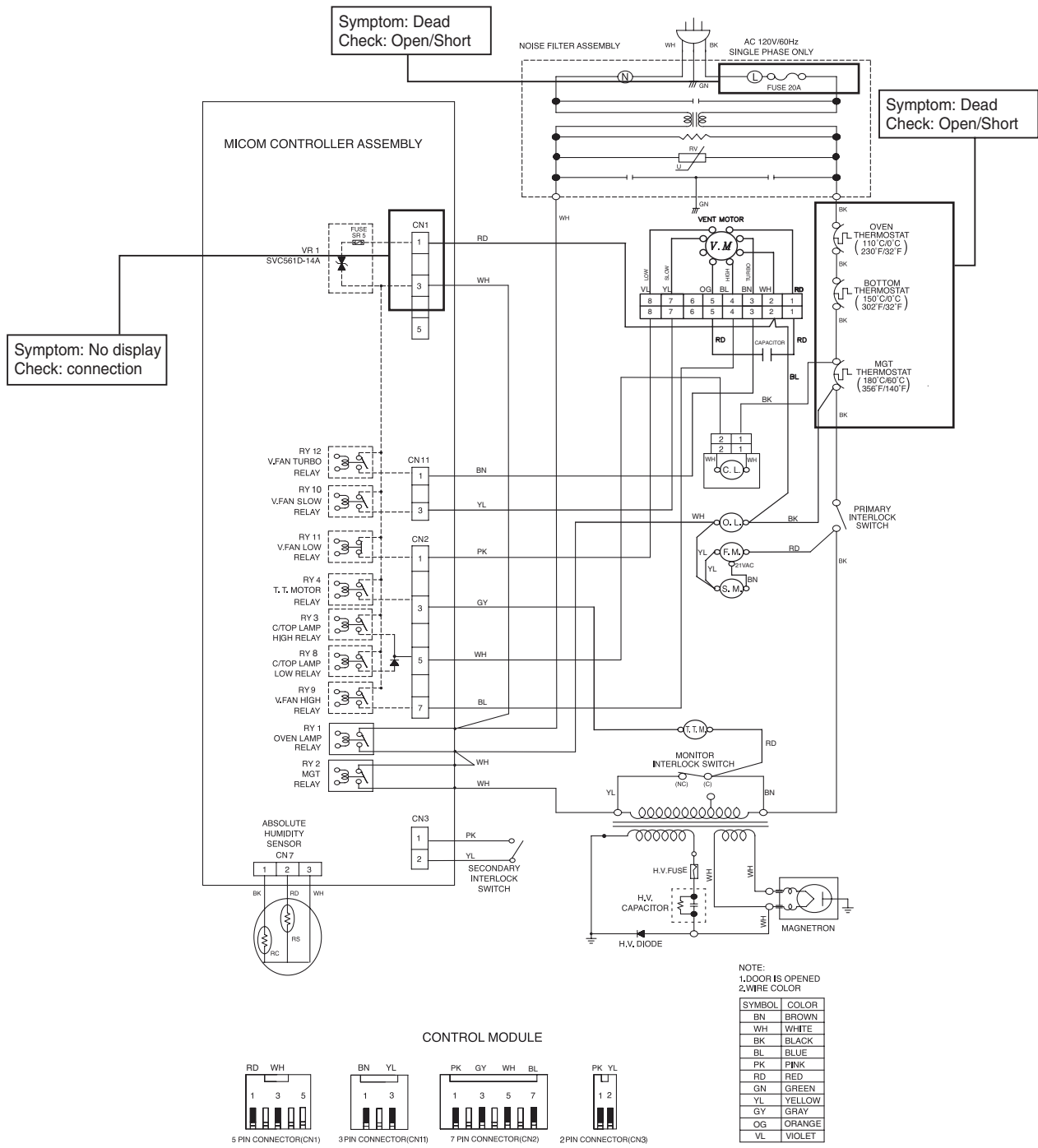

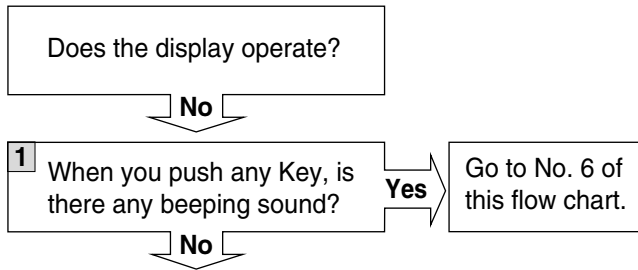

Power Off

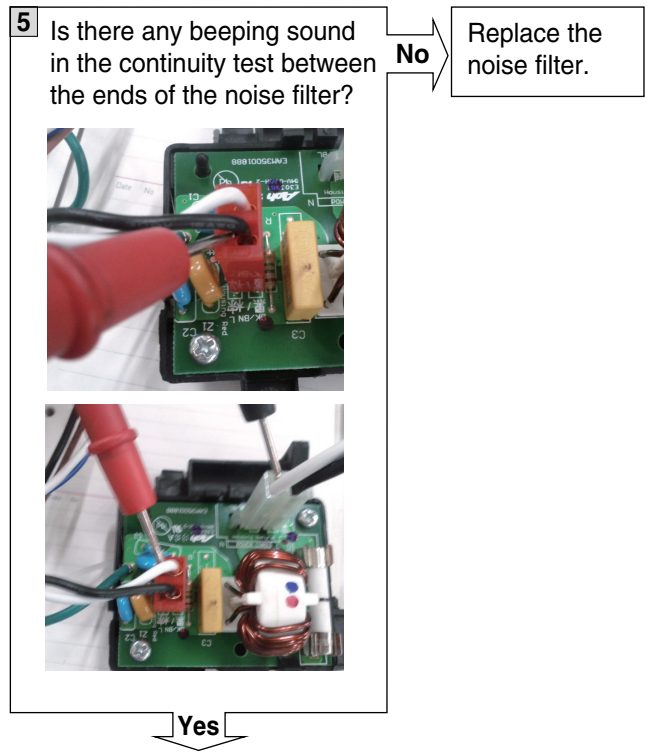
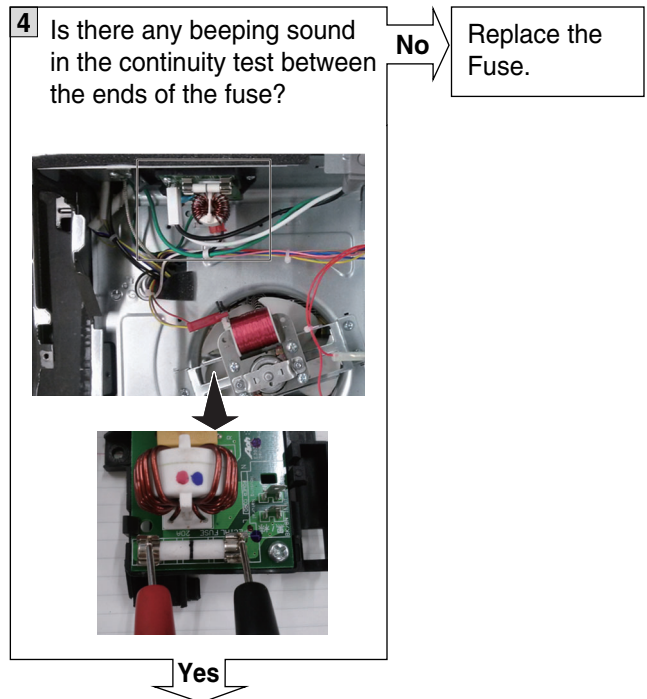
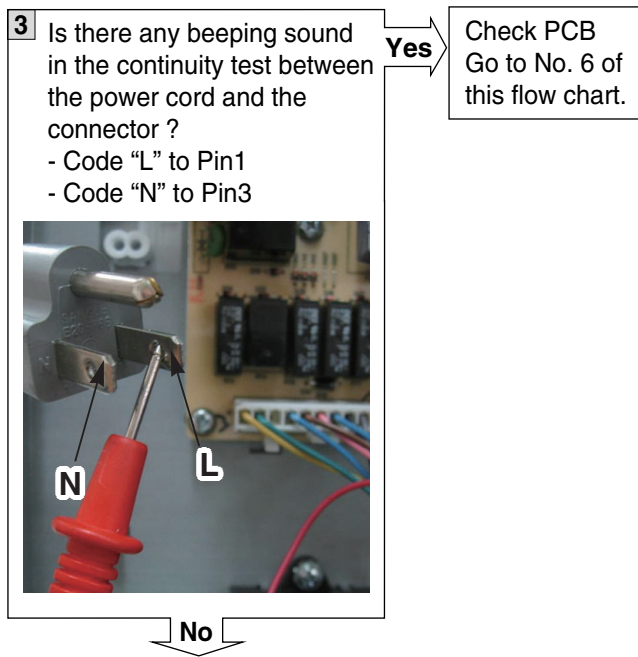
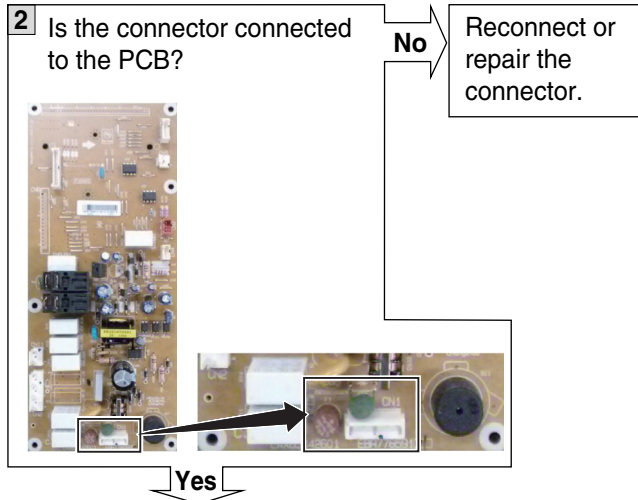

6 **Replace the PCB.
(EBR75341201)**

Keypad Failure

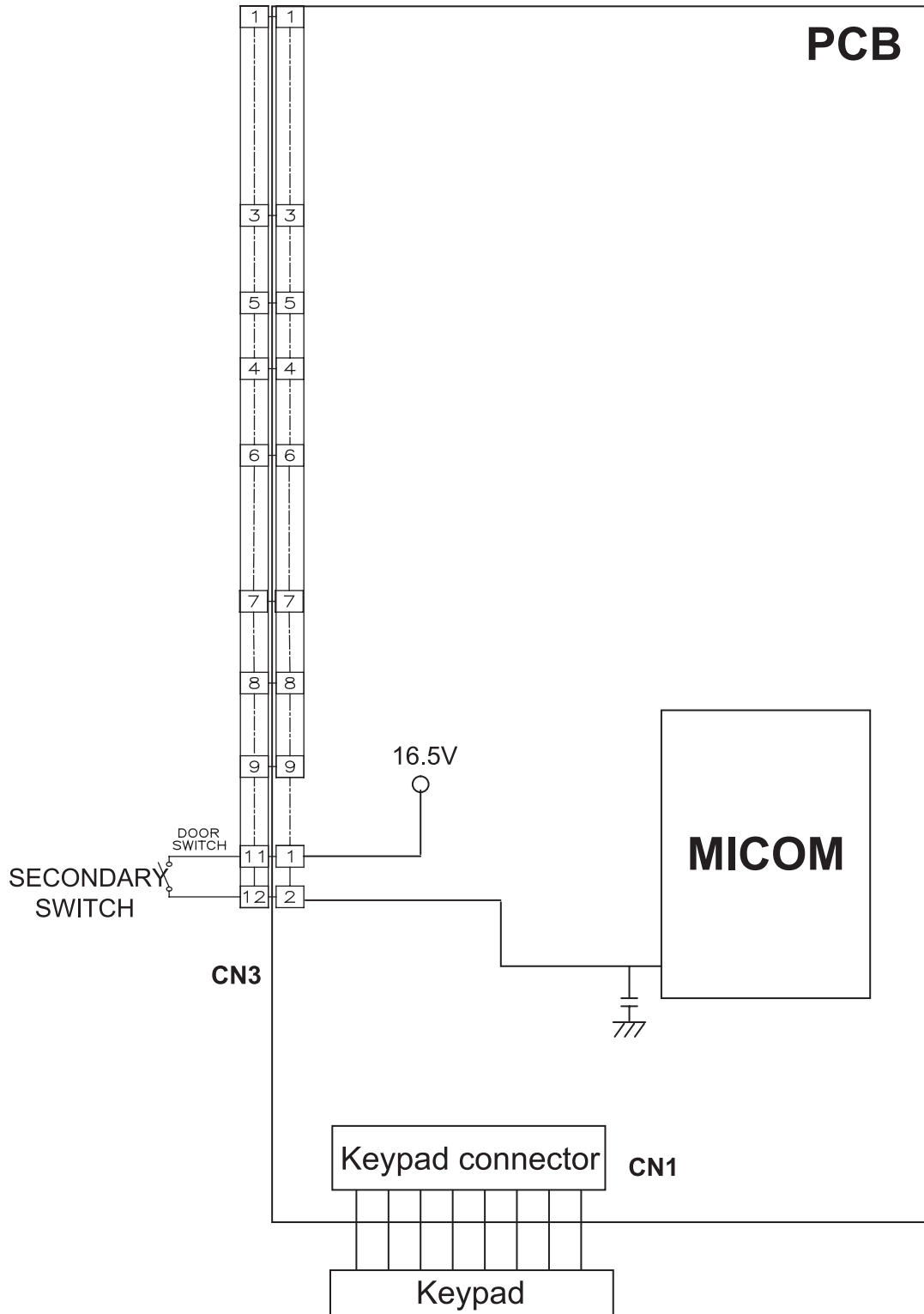

Do the keys operate?

No

Power ON

1 Do only the START key and EZ-ON keys operate?
(Door should be closed.)

No

Check PWB
Go to No. 4 of this flow chart.

Yes

2 Is there a beeping sound in the continuity test between the ends of the latch board?
- Secondary switch
(Door should be closed.)

No

Adjust latch board
(Refer to section 9-1,9-2)

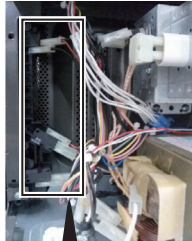

Yes

3 When the door is opened, is the voltage of the door sensing part over 4 V?
(CN3 Pin1 and Pin2)

No

Replace the PCB
(EBR75341201)

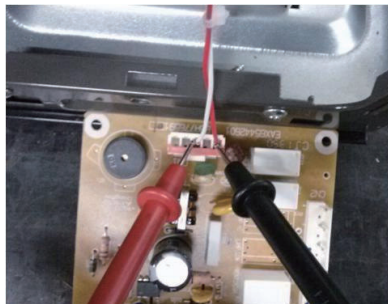

Yes

4 Is the connector connected to the PCB disconnected or disassembled?

Yes

Reconnect or repair the connector.

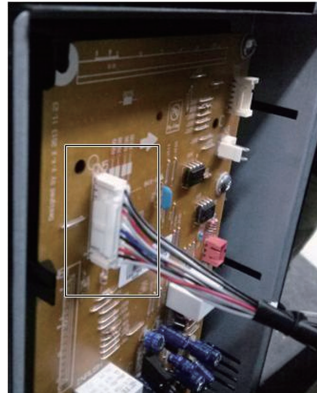

No

5 Replace the keypad?

No

6 Replace the PCB.
(EBR75341201)

No Heat / No Cook

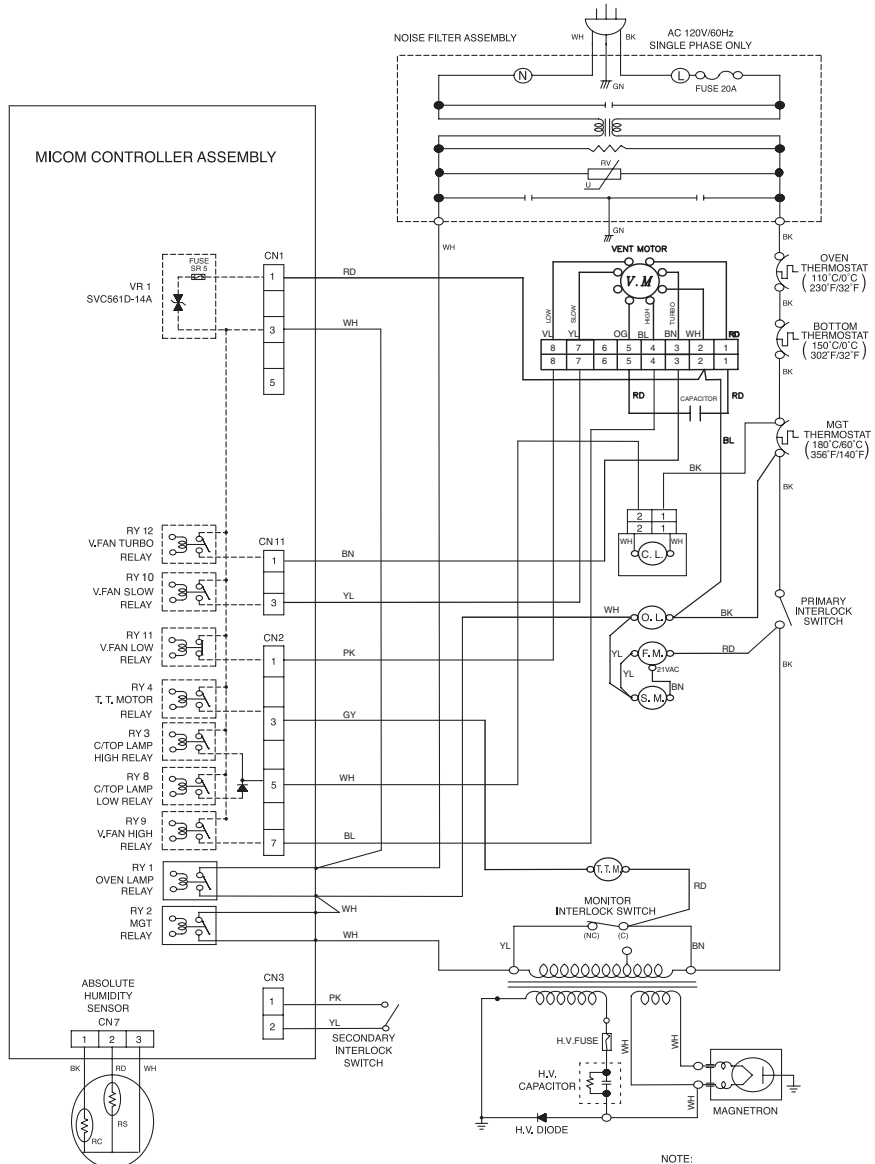

NOTE:
1. DOOR IS OPENED
2. WIRE COLOR

SYMBOL	COLOR
BN	BROWN
WH	WHITE
BK	BLACK
BL	BLUE
PK	PINK
RD	RED
GN	GREEN
YL	YELLOW
GY	GRAY
OG	ORANGE
VL	VIOLET

CONTROL MODULE

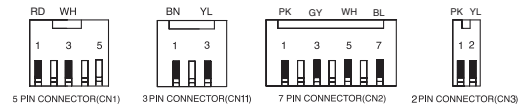

After power on, does the product operate?

No

1 Repeat Door Open and close at least three times. Does product operate?

No

Yes
Alternate explanation
(refer to the Note)

2 Is there any beeping sound in the continuity test between TAB1 and TAB2?

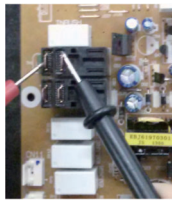
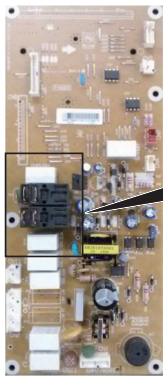

Yes
PCB no problem

No

3 While the product is operating under EZ-ON start, is the voltage of both ends of the D35 over 8 V?

Yes

Replace the Relay 2

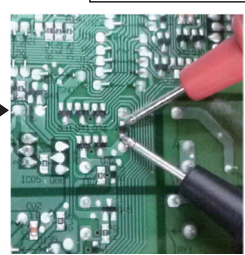
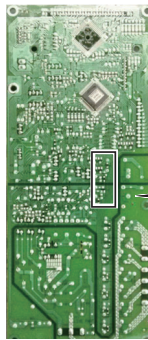

No

4 Replace the PCB. (EBR75341201)

[Note]

If something is caught in the door or in the sealing area, the microwave oven cannot operate safely. The latch switches and monitor switch will prevent operation.

Power Off

5 Is there any beeping sound in the continuity test between the ends of the latch board? (Door should be closed)

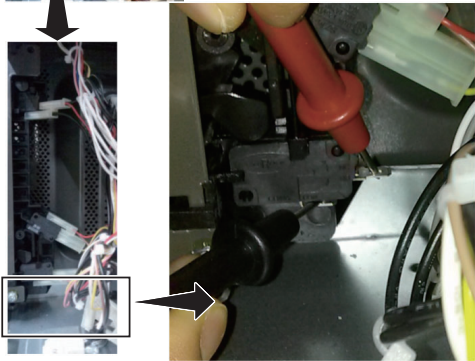
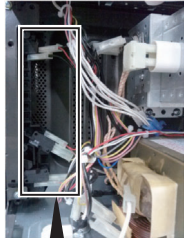

No Adjust the latch board
(Refer to section 9-1,9-2)

Yes

6 Is the connector connected to High Voltage Transformer assembly disconnected or disassembled?

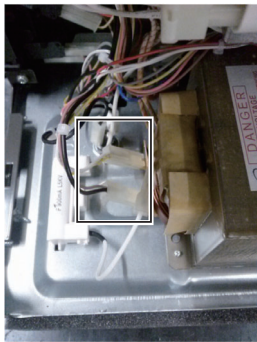
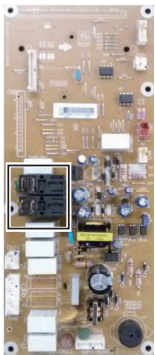

Yes Reconnect or repair the connector.

No

7 Is the resistance of the high voltage Transformer out of range?

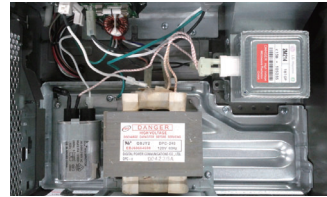

Yes Replace the High Voltage Transformer.

Test Point

1. Primary winding: 0.2 ~ 0.5 Ohm

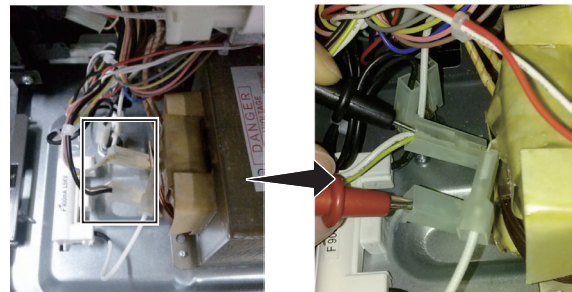

2. Secondary: 50 ~ 120 Ohm

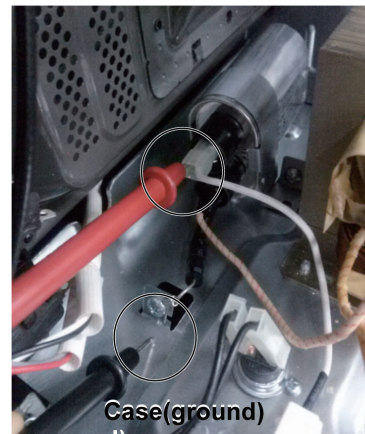

3. Filament winding: 0 Ohm

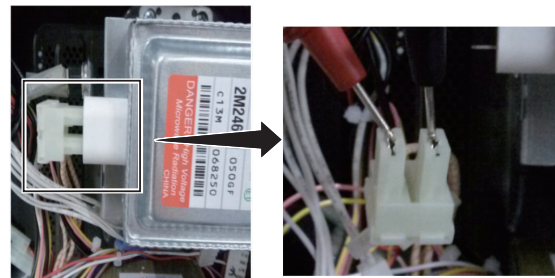

No

8 Is the connector connected to High Voltage capacitor assembly disconnected or disassembled?



Yes → Reconnect or repair the connector.

No ↓

11 Is the resistance of the high voltage diode out of range? (refer to section 10)



No → Replace the high voltage Diode.

Yes ↓

9 Is the resistance of the high voltage capacitor out of range? (refer to section 10)

Test Point

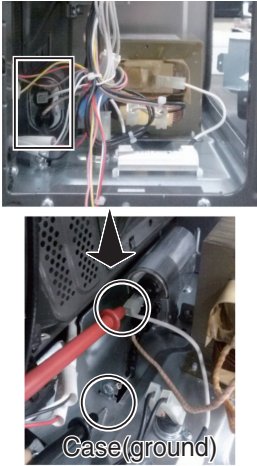

Yes → Replace the high voltage capacitor.

No ↓

12 Is the connector connected to the magnetron assembly disconnected or disassembled?

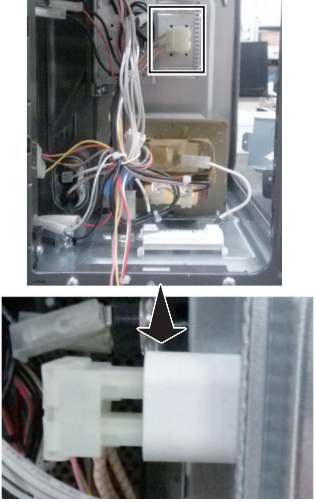

Yes ↓

Reconnect or repair the connector.

10 Is the connector connected to the high voltage diode assembly disconnected or disassembled?



Yes → Reconnect or repair the connector.

No ↓

Turntable Motor Does Not Work

Power ON

1 Does the turntable motor operate?

No → Replace the turntable motor.

Yes ↓

2 When door is closed, does the oven lamp turn on?

Yes → Adjust the Primary latch board (refer to section 9-1,9-2)

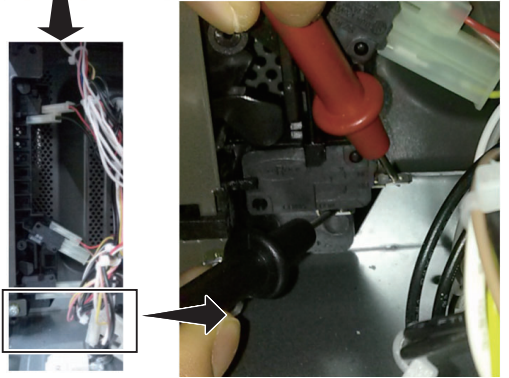
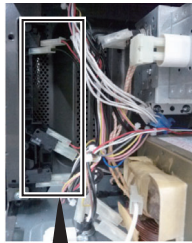

No ↓

3 Push the EZ-ON button (operate). Is the voltage of both ends of the D37 over 8 V?

No → Replace the PCB (EBR75341201)

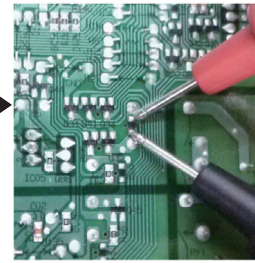
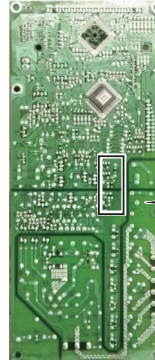

Yes ↓

4 Is there any beeping sound in the continuity test between the ends of two Pin of RY1?

No → Replace the PCB (EBR75341201)

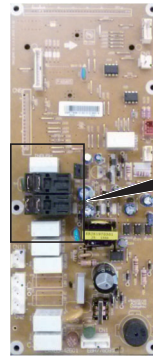

Yes ↓

5 PCB No Problem

Turns on automatically

Does the product turn on automatically without pushing the start key?

Yes

1 Repeat door open and close at least three times. Does the product operate?

Yes

Alternate explanation (refer to the Note on p. 19)

No

2 Is there any beeping sound in the continuity test between the ends of the latch board? - Secondary switch (Door should be closed.)

No

Adjust latch board (refer to section 9-1, 9-2)

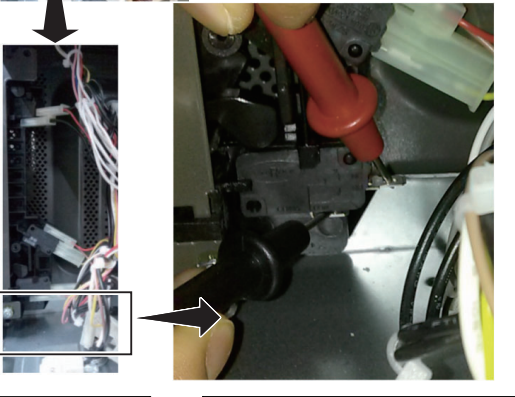
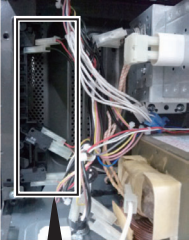

Yes

Power ON

3 When the door is closed, does the oven lamp turn on?

No

Replace the turntable motor.

Yes

4 When the door is opened, is the voltage of the door sensing part over 4 V? (Pin 11 to Pin 12)

No

Replace the PCB (EBR75341201)

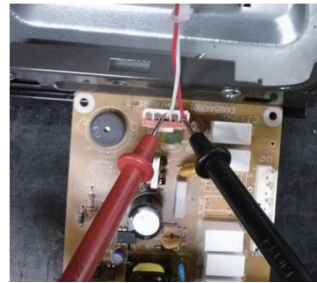

Yes

5 Is the voltage of both ends of the D37 over 8 V?

No

Replace the PCB (EBR75341201)

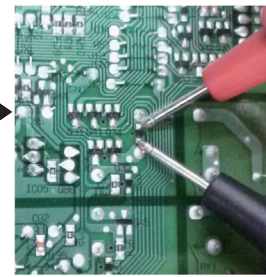
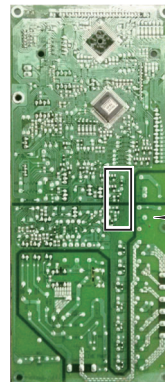

Yes

4 Is there any beeping sound in the continuity test between the ends of the two pins of RY1 ?

No

Replace the PCB (EBR75341201)

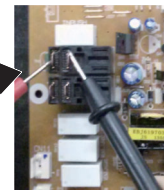
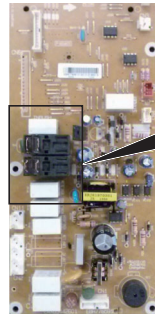

Yes

PCB No Problem

7. MICROWAVE LEAKAGE TEST

CAUTION

- **Be sure to check microwave leakage prior to servicing the oven if the oven is operating prior to servicing.**
- **Service personnel should inform the manufacturer, importer, or assembler of any certified oven unit found to have a microwave emission level in excess of 5 mW/cm²** and should repair any unit found to have excessive emission levels at no cost to the owner and should ascertain the cause of the excessive leakage. The service personnel should instruct the owner not to use the unit until the oven has been brought into compliance.
- If the oven operates with the door open, service personnel should;
 - Tell the user not to operate the oven
 - Contact the manufacturer and CDRH (Center for Devices and Radiological Health) immediately.

NOTE: Address to CDRH

Office of Compliance (HFZ-312)
Center for Devices and Radiological Health
1390 Piccard Drive Rockville, Maryland 20850

- Service personnel should check all surface and vent openings for microwave emission testing.
- Check for microwave energy leakage after every servicing. The power density of the microwave radiation leakage emitted by the microwave oven should not exceed 1mW/cm².sq. Always start measuring of an unknown field to assure safety for operating personnel from radiation leakage.

NOTE: The standard is 5mW/cm².sq. while in the customer's home. 1mW/cm².sq. stated here is manufacturer's own voluntary standard for units in customer's home.

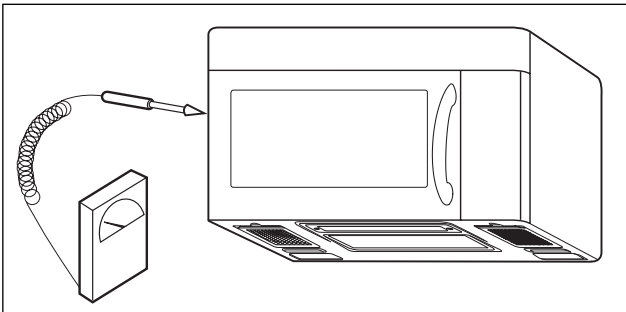

EQUIPMENT-

- TESTER ((VOLTS-DC, AC, Ohmmeter)
- Microwave survey meter
 - Holaday HI-1500
 - HI-1501
 - Narda 8100
 - 8200
- 600 cc non conductive material beaker (glass or plastic), inside diameter: approx. 8.5 cm (3 1/2 in.)
- Glass thermometer: 100 °C or 212 °F (1 deg scale)

MEASURING MICROWAVE ENERGY LEAKAGE

- **Pour 275±15cc of 20±5°C(68±9°F) water in a beaker which is graduated to 600 cc, and place the beaker in the oven.**
- **Set the energy leakage monitor to 2,450 MHz and use it following the manufacturer's recommended test procedure to assure correct result.**
- **When measuring the leakage, always use the 2-inch (5cm) spacer supplied with the probe.**
- **Operate the oven at its maximum output.**
- **Measure the microwave radiation using an electromagnetic radiation monitor by holding the probe perpendicular to the surface being measured.**

Move probe along shaded area.

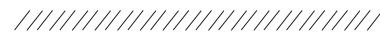

Probe scanning speed
Less than 2.5 cm/sec. (1 in/sec)

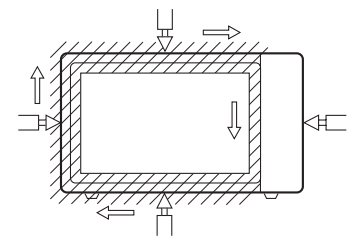

MEASUREMENT WITH THE OUTER CASE REMOVED

- (1) When you replace the magnetron, measure for microwave energy leakage before the outer case is installed and after all necessary components are replaced or adjusted. Special care should be taken in measuring the following parts.
- Around the magnetron
 - The waveguide

WARNING: AVOID CONTACTING ANY HIGH VOLTAGE PARTS.

MEASUREMENT WITH A FULLY ASSEMBLED OVEN

- (1) After all components, including the outer panels, are fully assembled, measure for microwave energy leakage around the door viewing window, the exhaust opening and air inlet openings.
- (2) Microwave energy leakage must not exceed the values prescribed below.

NOTES:

Leakage with the outer panels removed than 5 mW/cm².

Leakage for a fully assembled oven (before the latch switch [primary] is interrupted) with the door in a slightly opened position -less than 1 mW/cm²

NOTE WHEN MEASURING

- (1) Do not exceed meter full scale deflection.
- (2) The test probe must be removed no faster than 1 inch/sec (2.5cm/sec) along the shaded area, otherwise a false reading may result.
- (3) The test probe must be held with the grip portion of the handle. A false reading may result if the operator's hand is between the handle and the probe.
- (4) When testing near a corner of the door, keep the probe perpendicular to the surface making sure to move the probe horizontally along the oven surface. Doing so will avoid possible damage to the probe.

RECORD KEEPING AND NOTIFICATION AFTER MEASUREMENT

- (1) After adjustment and repair of any microwave energy interruption or microwave energy blocking device, record the measured values for future reference. Also enter the information on the service invoice.
- (2) Should the microwave energy leakage not be more than 1 mW/cm², determine that all parts are in good condition, functioning properly and that genuine replacement parts which are listed in this manual have been used.
- (3) At least once a year, have the electromagnetic energy leakage monitor checked for calibration by its manufacturer.

8. POWER OUTPUT MEASUREMENT

- (1) Microwave power output measurement is made with the microwave oven supplied at its rated voltage and operated at its maximum microwave power setting with a load of (1000 ± 5) g of potable water.
- (2) The water is contained in a cylindrical borosilicate glass vessel having a maximum material thickness of $1/8$ " (3 mm) and an outside diameter of approximately 7.6" (190mm).
- (3) The oven and the empty vessel are at ambient Temperature (T_0) prior to the start of the test.
- (4) The initial temperature (T_1) of the water is (10 ± 1) °C (50°F) It is measured immediately before the water is added to the vessel. After addition of the water to the vessel, the load is immediately placed on the center of the turntable which is in the lowest position and the microwave power is then switched on.
- (5) The time t for the temperature of the water to rise by a value T of (10 ± 1) °K is measured, where t is the time in seconds and T is the temperature rise. The initial and final water temperatures are selected so that the maximum difference between the final water temperature and the ambient temperature is 5°K.
- (6) The microwave power output P in watts is calculated from the following formula:

$$P = \frac{4.187 Mw(T_2 - T_1) + 0.55Mc(T_2 - T_0)}{t}$$

is measured while the microwave generator is operating at full power. Magnetron filament heat-up time is not included. (about 3 seconds)

- (7) The water is stirred to equalize temperature throughout the vessel, prior to measuring the final water temperature.
- (8) Stirring devices and measuring instruments are selected in order to minimize addition or removal of heat.

Where

P is the microwave power output, in watts

Mw is the mass of the water, in grams

Mc is the mass of the container, in grams

T0 is the ambient temperature, in °C

T1 is the initial temperature of the water, in °C

T2 is the final temperature of the water, in °C

t is the heating time in seconds, excluding the magnetron filament heat-up time.

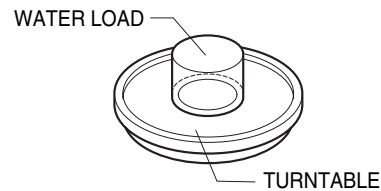

9. INTERLOCK SYSTEM

9-1. Interlock Mechanism

The door lock mechanism is a device which has been specially designed to eliminate completely microwave activity when the door is opened during cooking and thus to prevent the danger resulting from microwave leakage.

ADJUSTMENT PROCEDURES

To avoid possible exposure to microwave energy leakage, adjust the door latches and interlock switches, using the following procedure.

The Interlock Monitor and Primary Interlock Switch act as the final safety switch protecting the user from microwave energy. The terminals between COM and NC of the Interlock Monitor must close when the door is opened. After adjusting the Interlock Monitor Switch, make sure that it is correctly connected. Mounting of the primary/monitor/secondary switches to the latch board.

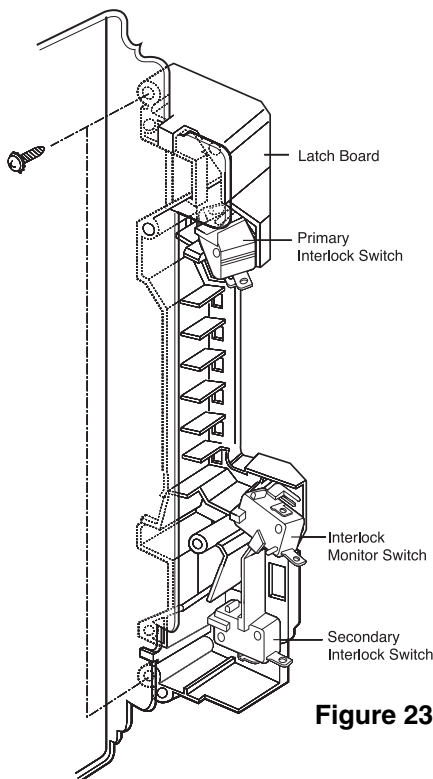

Figure 23-a

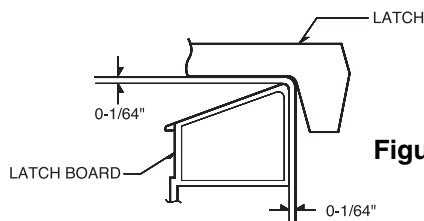

Figure 23-b

CHECK THE DOOR LATCH AND SWITCH CLOSING.

NOTE:

The outer cover of the microwave oven is removed.

- (1) Set the microwave oven on its side so that you can see the latch board and the switches, as shown in Figure 23-a.
- (2) Close the door tightly and check gaps A and B to be sure they are no more than 1/64" (0.5 mm). See Figure 23-b for close-up view of gaps A and B (door latches). If all gaps are less than 1/64" (0.5 mm), adjustment of the latch board may not be necessary. Go to Steps 5 and 6 to check the sequence of the switches.

NOTE:

The correct sequence of the Primary Interlock Switch, Secondary Interlock Switch and the Interlock Monitor Switch is very important.

If any gap is larger than 1/64" (0.5 mm), you will need to adjust the latch board. Go to step 3 and follow all steps in order.

ADJUST THE LATCH AND SWITCH CLOSING

- (3) Loosen the two screws holding the plastic latch board as shown.
- (4) With the oven door closed tightly, move the latch board upward toward the top of the oven and/or away from the door latch until the gaps are less than 1/64" (0.5 mm). Hold the latch board tightly in this position until you check the sequence of the switches in steps 5 and 6.

SPECIFICATIONS

TEST THE LATCH AND SWITCH SEQUENCE

- (5) Open the oven door slowly. Watch the door latch and the Secondary Switch. Release the rod and lever on the switches to make sure they are zero to the body of the switches in the following sequence:

- Primary Interlock Switch
- Secondary Interlock Switch
- Interlock Monitor Switch

Adjust the latch board until the switches operate in this sequence. See Steps 3 and 4.

- (6) Close the oven door slowly and be sure it is tightly closed. Watch the three switches to make sure they are zero to the body of the switches in the following sequence:

- Interlock Monitor Switch
- Primary Interlock Switch
- Secondary Interlock Switch

NOTE: The Interlock Monitor Switch is an added safety check on the Primary and Secondary Interlock Switches. If the Primary and Secondary Interlock Switches allow the oven to operate with the door open, the Monitor Switch will blow the

fuse.

- (7) When you achieve the proper sequence of switches in Steps 5 and 6, tighten the latch board screws at that point.

TEST THE MICROWAVE ENERGY LEAKAGE

Make sure the microwave energy leakage is below the limit of 1mW/cm² (with a 275 ml water load) and 5mW/cm² (with a 275 ml water load without the cabinet) when measured with a survey meter.

9-2. Interlock Continuity Test

A. PRIMARY INTERLOCK SWITCH TEST

When the door is opened slowly, an audible **click** should be heard at the same time or successively at intervals and the latches should activate the switches with an audible **click**.

If the latches do not activate the switches when the door is closed, the switches should be adjusted in accordance with the adjustment procedure.

Disconnect the wire lead from the primary switch. Connect the ohmmeter leads to the common (COM) and normally open (NO) terminal of the switch. The meter should indicate an open circuit in the door open condition.

When the door is closed, the meter should indicate a closed circuit.

If the primary switch operation is abnormal, make the necessary adjustment or replace the switch, making sure to replace it with the same type of switch.

B. SECONDARY INTERLOCK SWITCH TEST







Disconnect the wire lead from the secondary switch.

Connect the ohmmeter leads to the common (COM) and normally open (NO) terminals of the switch. The meter should indicate an open circuit in the door open condition. When the door is closed, the meter should indicate a closed circuit. If the secondary switch operation is abnormal, make the necessary adjustment or replace the switch, making sure to replace it with the same type of switch.

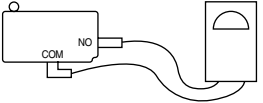
C. MONITOR SWITCH TEST

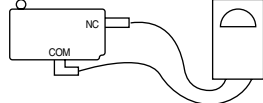
Disconnect the wire lead from the monitor switch. Connect the ohmmeter leads to the common (COM) and normally closed (NC) terminals of the switch. The meter should indicate a closed circuit in the door open condition. If the door is closed, the meter should indicate an open circuit. If the monitor switch operation is abnormal, replace it with the same type of switch.

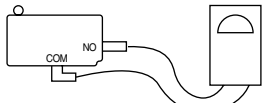
NOTE: After repairing the door or the interlock system, it is necessary to do this continuity test before operating the oven.

COMPONENTS	TEST PROCEDURE	RESULTS	
		Door open	Door closed
SWITCHES (Wire leads removed)	Check for continuity of the switch with an ohmmeter		
	Primary Switch 		
	Monitor Switch 		
	Secondary Switch 		
NOTE : After checking for the continuity of the switches, make sure that they are connected correctly.			

WARNING : FOR CONTINUED PROTECTION AGAINST EXCESSIVE RADIATION EMISSION, REPLACE ONLY WITH IDENTICAL REPLACEMENT PARTS.

TYPE NO.SZM-V16-FA-63 OR VP-533A-OF OR V-5230Q FOR PRIMARY SWITCH

TYPE NO.SZM-V16-FA-62 OR VP-532A-OF OR V-5220Q FOR MONITOR SWITCH

TYPE NO.SZM-V16-FA-63 OR VP-533A-OF OR V-5230Q FOR SECONDARY SWITCH

10. COMPONENT TESTING INFORMATION

CAUTION

1. DISCONNECT THE POWER SUPPLY CORD FROM THE OUTLET WHENEVER REMOVING THE OUTER CASE FROM THE UNIT. PROCEED WITH THE TEST ONLY AFTER DISCHARGING THE HIGH VOLTAGE CAPACITOR AND REMOVING THE LEAD WIRES FROM THE PRIMARY WINDING OF THE HIGH VOLTAGE TRANSFORMER.
2. ALL OPERATIONAL CHECKS WITH MICROWAVE ENERGY MUST BE DONE WITH A LOAD (1 LITER OF WATER IN CONTAINER) IN THE OVEN.

A. TEST PROCEDURES

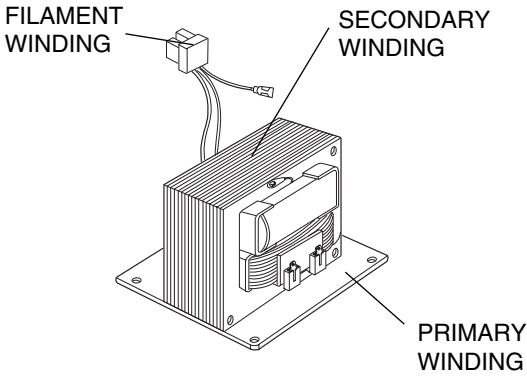
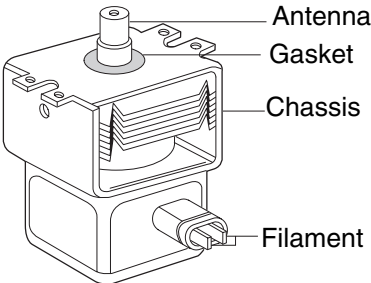
COMPONENTS	TEST	RESULTS
<p>TRANSFORMER</p>	 <ol style="list-style-type: none"> 1. Remove wire leads. 2. Measure resistance. (ohm meter scale: Rx1) <ul style="list-style-type: none"> • Primary winding • Secondary winding • Filament winding 3. Measure resistance. (ohm meter scale: Rx1000) <ul style="list-style-type: none"> • Primary winding to ground • Filament winding to ground 	<p>Approx. 0.3 to 0.5 ohms Approx. 65 to 120 ohms 0 ohm</p> <p>Normal: Infinite Normal: Infinite</p>
<p>MAGNETRON</p>	 <ol style="list-style-type: none"> 1. Remove wire leads. Install the magnetron seal in the correct position. Check that the seal is in good condition. 2. Measure resistance. (ohm meter scale: Rx1) <ul style="list-style-type: none"> • Filament terminal 3. Measure resistance. (ohm meter scale: Rx1000) <ul style="list-style-type: none"> • Filament to chassis 	<p>Normal: Less than 1 ohm</p> <p>Normal: Infinite</p>

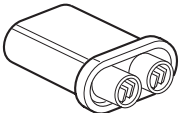
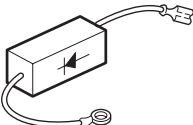
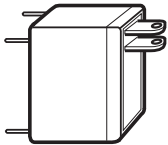
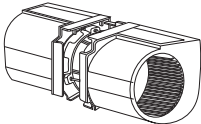
COMPONENTS	TEST	RESULTS																																	
<p>CAPACITOR</p>	<p>1. Remove wire leads. 2. Measure resistance. (ohm meter scale: Rx1000)</p> <ul style="list-style-type: none"> • Terminal to terminal • Terminal to case 	<p>Normal: Momentarily Infinite and then soon reach 10 mega. ohms</p> <p>Normal: Infinite.</p>																																	
<p>DIODE Some inexpensive ohm meters may indicate infinite resistance in both directions.</p>	<p>1. Measure continuity. Forward. (ohm meter scale: Rx1000)</p> <p>2. Measure continuity. Reverse. (ohm meter scale: Rx1000)</p> 	<p>Normal: Below 100 ohms Abnormal: Infinite</p> <p>Normal: Infinite. Abnormal: Below 100 ohms</p>																																	
<p>RELAY 2</p>	<p>1. Measure continuity. (ohm meter scale: Rx1)</p> <p>2. Remove the lead wires and operate oven at power level 1 through power level 10.</p> 	<table border="1"> <thead> <tr> <th>Power Level</th> <th>Open</th> <th>Close</th> </tr> </thead> <tbody> <tr><td>1</td><td>4 Sec</td><td>18 Sec</td></tr> <tr><td>2</td><td>6 Sec</td><td>16 Sec</td></tr> <tr><td>3</td><td>8 Sec</td><td>14 Sec</td></tr> <tr><td>4</td><td>10 Sec</td><td>12 Sec</td></tr> <tr><td>5</td><td>12 Sec</td><td>10 Sec</td></tr> <tr><td>6</td><td>14 Sec</td><td>8 Sec</td></tr> <tr><td>7</td><td>16 Sec</td><td>6 Sec</td></tr> <tr><td>8</td><td>18 Sec</td><td>4 Sec</td></tr> <tr><td>9</td><td>20 Sec</td><td>2 Sec</td></tr> <tr><td>10</td><td>22 Sec</td><td>0 Sec</td></tr> </tbody> </table>	Power Level	Open	Close	1	4 Sec	18 Sec	2	6 Sec	16 Sec	3	8 Sec	14 Sec	4	10 Sec	12 Sec	5	12 Sec	10 Sec	6	14 Sec	8 Sec	7	16 Sec	6 Sec	8	18 Sec	4 Sec	9	20 Sec	2 Sec	10	22 Sec	0 Sec
Power Level	Open	Close																																	
1	4 Sec	18 Sec																																	
2	6 Sec	16 Sec																																	
3	8 Sec	14 Sec																																	
4	10 Sec	12 Sec																																	
5	12 Sec	10 Sec																																	
6	14 Sec	8 Sec																																	
7	16 Sec	6 Sec																																	
8	18 Sec	4 Sec																																	
9	20 Sec	2 Sec																																	
10	22 Sec	0 Sec																																	
<p>VENTILATION MOTOR</p>	<p>1. Remove lead wires. 2. Measure resistance. (ohm meter scale: Rx1)</p> <p>Turbo speed : White and Brown High speed: White and Blue Low speed: White and Violet Slow speed: white and Yellow</p> 	<p>Normal: Turbo speed: Approximately 20~25ohms High speed: Approximately 40~45ohms Low speed: Approximately 50~55ohms Slow speed: Approximately 60~65ohms</p>																																	

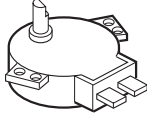
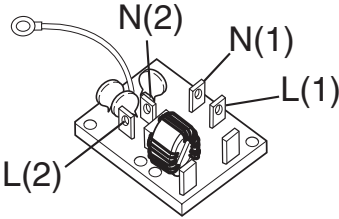
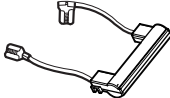
COMPONENTS	TEST	RESULTS
<p>TURNTABLE MOTOR</p>	<p>1. Remove wire leads. 2. Measure resistance. (ohm meter scale: Rx1000)</p> 	<p>Normal: Approximately 2.5 to 3.5 Kohms</p> <p>Abnormal: Infinite or several.</p>
<p>NOISE FILTER</p>	<p>1. Unplug microwave oven or disconnect power. 2. Remove wire 3. Measure resistance (ohmmeter scale:Rx1).</p> 	<p>Normal: L(1)-L(2)(coil):Less than 1 ohm N(1)-N(2)(coil):Less than 1 ohm Abnormal:infinite Normal: L(1) or L(2)-N(1) or N(2) (resistor: 1.5M ohms Abnormal: 0 ohms</p>
<p>HIGH VOLTAGE FUSE</p>	<p>test 1.Depart from other components. 2.Measure Resistance. (ohm meter scale Rx1)</p> 	<p>Normal : under 10ohm Abnormal : infinite.</p>

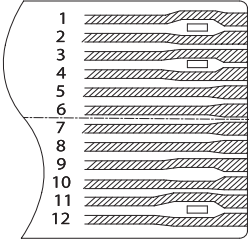
COMPONENTS	TEST	RESULTS																																																														
<p>TOUCH KEY BOARD</p>	<p>Measure the resistance between terminal pins of connector KEY CONNECTOR. NOTE: When reconnecting the FPC connector, make sure that the holes on the FPC connector are properly engaged with hooks on the plastic fastener.</p> <p style="text-align: center;">MATRIX CIRCUIT FOR TOUCH KEY BOARD CONNECTOR (KEY CON)</p> <p><u>KEY MATRIX</u></p> <table border="1" data-bbox="488 751 1118 1010"> <thead> <tr> <th>2st</th> <th>1</th> <th>2</th> <th>3</th> <th>4</th> <th>5</th> <th>6</th> <th>7</th> </tr> </thead> <tbody> <tr> <td>8</td> <td></td> <td></td> <td></td> <td></td> <td></td> <td></td> <td></td> </tr> <tr> <td>9</td> <td>Clear</td> <td>Vent Hi/Low/Off</td> <td>Clock</td> <td>Energy Saving</td> <td>Add 30 Sec.</td> <td>Quick Defrost</td> <td>Soften</td> </tr> <tr> <td>10</td> <td>1</td> <td>2</td> <td>3</td> <td>4</td> <td>5</td> <td>6</td> <td>Melt</td> </tr> <tr> <td>11</td> <td>7</td> <td>8</td> <td>9</td> <td>0</td> <td>Timer</td> <td>Sensor Reheat</td> <td>Less</td> </tr> <tr> <td>12</td> <td>Sensor Popcorn</td> <td>N.A</td> <td>N.A</td> <td>time & weight Defrost</td> <td>Sensor Cook</td> <td>N.A</td> <td>More</td> </tr> <tr> <td>13</td> <td>Start</td> <td>C/T Lamp On/Off</td> <td>Hold Warm</td> <td>N.A</td> <td>Time Cook</td> <td>Power Level</td> <td>Turntable On/Off</td> </tr> </tbody> </table>	2st	1	2	3	4	5	6	7	8								9	Clear	Vent Hi/Low/Off	Clock	Energy Saving	Add 30 Sec.	Quick Defrost	Soften	10	1	2	3	4	5	6	Melt	11	7	8	9	0	Timer	Sensor Reheat	Less	12	Sensor Popcorn	N.A	N.A	time & weight Defrost	Sensor Cook	N.A	More	13	Start	C/T Lamp On/Off	Hold Warm	N.A	Time Cook	Power Level	Turntable On/Off	<table border="1" data-bbox="1146 327 1490 495"> <thead> <tr> <th>Resistance value</th> <th>When touched</th> <th>When not touched</th> </tr> </thead> <tbody> <tr> <td></td> <td>Less than 400 ohms</td> <td>More than 1 megaohm</td> </tr> </tbody> </table> <p style="text-align: center;">FPC CONNECTOR Top</p> 	Resistance value	When touched	When not touched		Less than 400 ohms	More than 1 megaohm
2st	1	2	3	4	5	6	7																																																									
8																																																																
9	Clear	Vent Hi/Low/Off	Clock	Energy Saving	Add 30 Sec.	Quick Defrost	Soften																																																									
10	1	2	3	4	5	6	Melt																																																									
11	7	8	9	0	Timer	Sensor Reheat	Less																																																									
12	Sensor Popcorn	N.A	N.A	time & weight Defrost	Sensor Cook	N.A	More																																																									
13	Start	C/T Lamp On/Off	Hold Warm	N.A	Time Cook	Power Level	Turntable On/Off																																																									
Resistance value	When touched	When not touched																																																														
	Less than 400 ohms	More than 1 megaohm																																																														

NOTES:

- A MICROWAVE ENERGY TEST MUST ALWAYS BE PERFORMED WHEN THE UNIT IS SERVICED FOR ANY REASON.
- MAKE SURE THE WIRE LEADS ARE IN THE CORRECT POSITION.
- WHEN REMOVING THE WIRE LEADS FROM THE PARTS, BE SURE TO GRASP THE CONNECTOR, NOT THE WIRES.

11. DISASSEMBLY INSTRUCTIONS

IMPORTANT NOTES:

THE UNIT MUST BE DISCONNECTED FROM THE ELECTRICAL OUTLET WHEN MAKING REPAIRS, REPLACEMENTS, ADJUSTMENTS AND CONTINUITY CHECKS.

WHEN RECONNECTING THE WIRE LEADS TO ANY PART, MAKE SURE THE WIRING CONNECTIONS AND LEAD COLORS ARE CORRECTLY MATCHED ACCORDING TO THE OVERALL CIRCUIT DIAGRAM. (ESPECIALLY THE SWITCHES AND THE HIGH VOLTAGE CIRCUIT.)

A. REMOVING POWER AND CONTROL CIRCUIT BOARD (Figures 1, 2 and, 3)

- (1) Remove the a screw securing the control panel assembly to the oven cavity.
- (2) Remove the control panel by pushing it upward.
- (3) Remove the connectors (cn1,cn3,cn5) and wire leads (RY1,RY2) from the circuit board.

- (4) Remove 5 screws securing the circuit board.

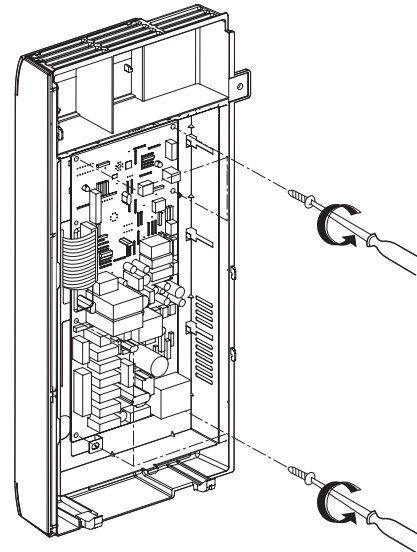

Figure 2

- (5) Remove the FPC connector from the terminal socket following HOW TO REMOVE THE FPC CONNECTOR on the next page.
- (6) Remove the circuit board from the control bracket carefully.

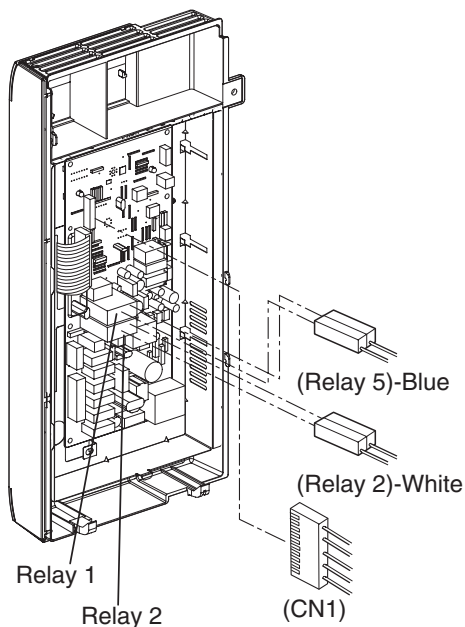

Figure 1

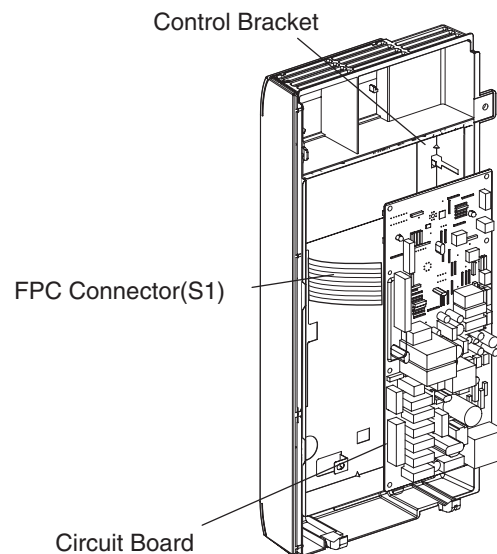

Figure 3

B. REMOVING THE OUTER CASE(Figure 8)

- (1) Remove the vent grille by removing the two screws securing it to the outer case.
- (2) Remove the two screws securing it to the air duct.
- (3) Remove the mounting plate by loosening the screws (1 or 2 screws) securing it to the outer case.
- (4) Remove two screws on the left central edge and one screw on the right central edge of the base plate.
Remove the fan bracket from the outer case by removing one screw securing it to the outer case.
- (5) Remove six screws of the rear cavity.
- (6) Remove the outer case.

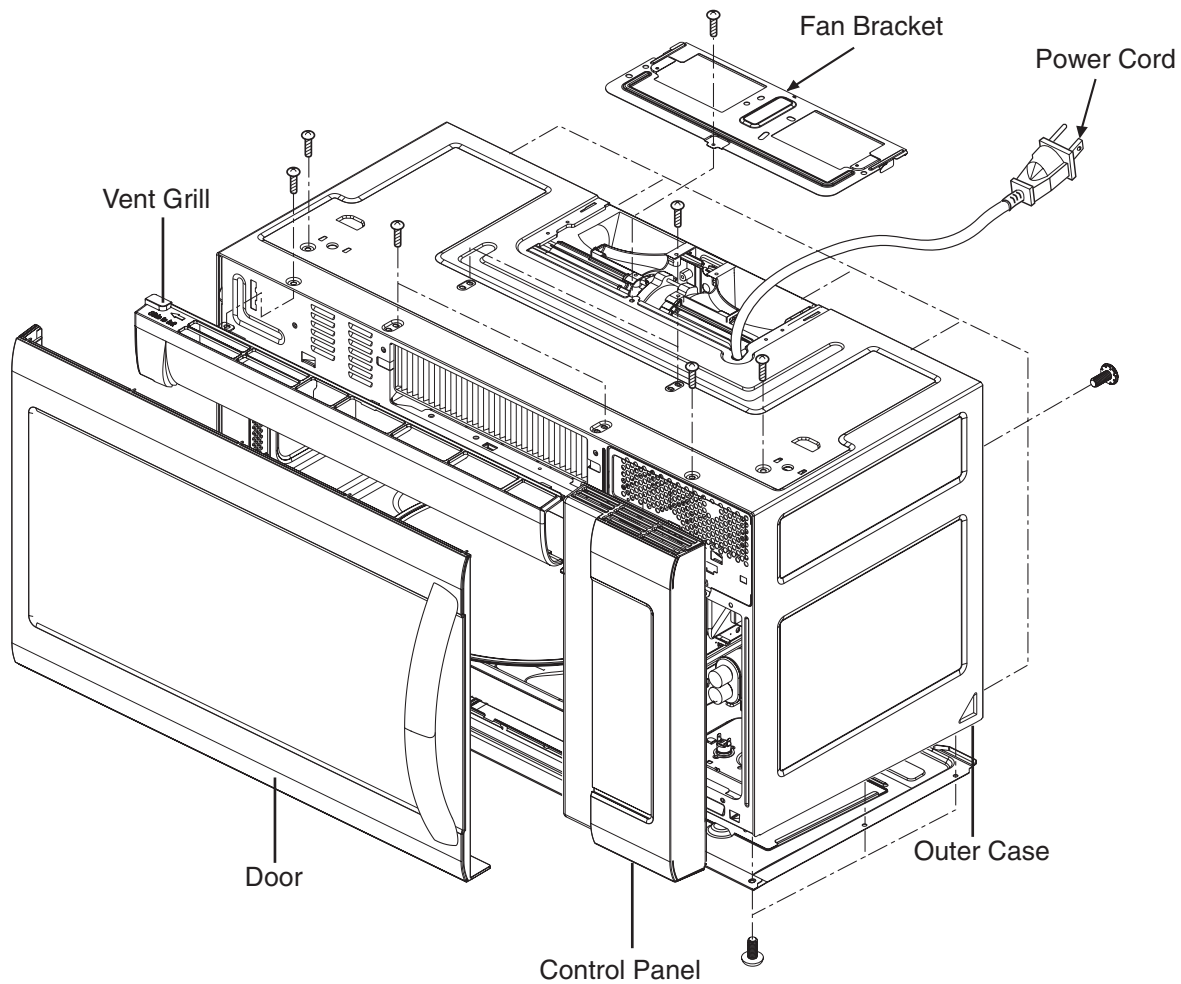

Figure 4

C. REMOVING THE DOOR INTERLOCK SWITCHES (Figures 9, 10)

- (1) Disconnect the wire leads from the interlock switches.
- (2) Remove the two screws securing the Latch Board.
- (3) Make any necessary replacements and check for microwave energy leakage according to ADJUSTMENT PROCEDURES on page 7-12.

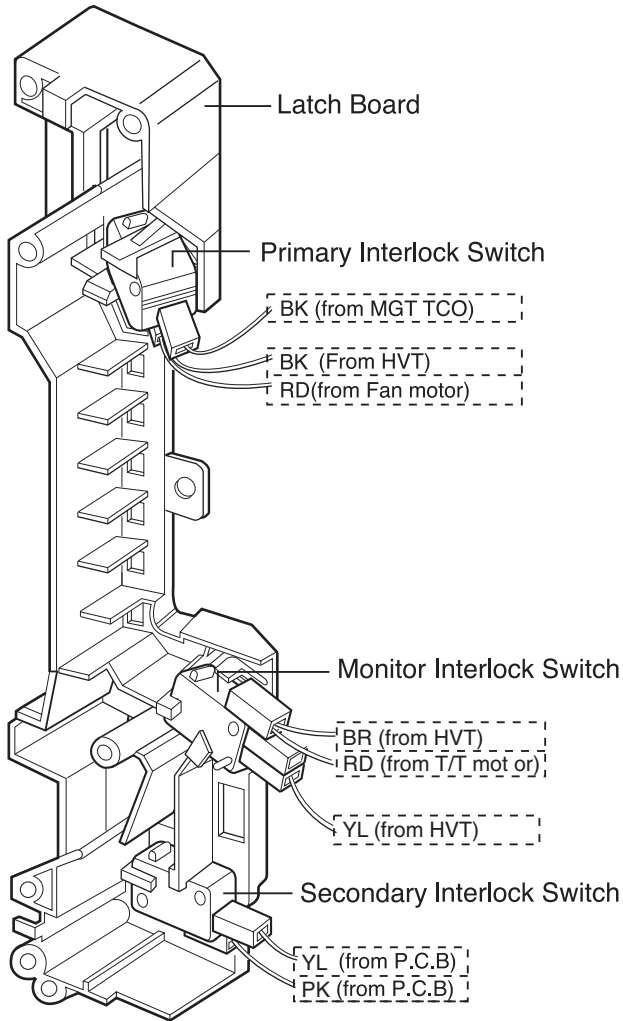

Figure 9

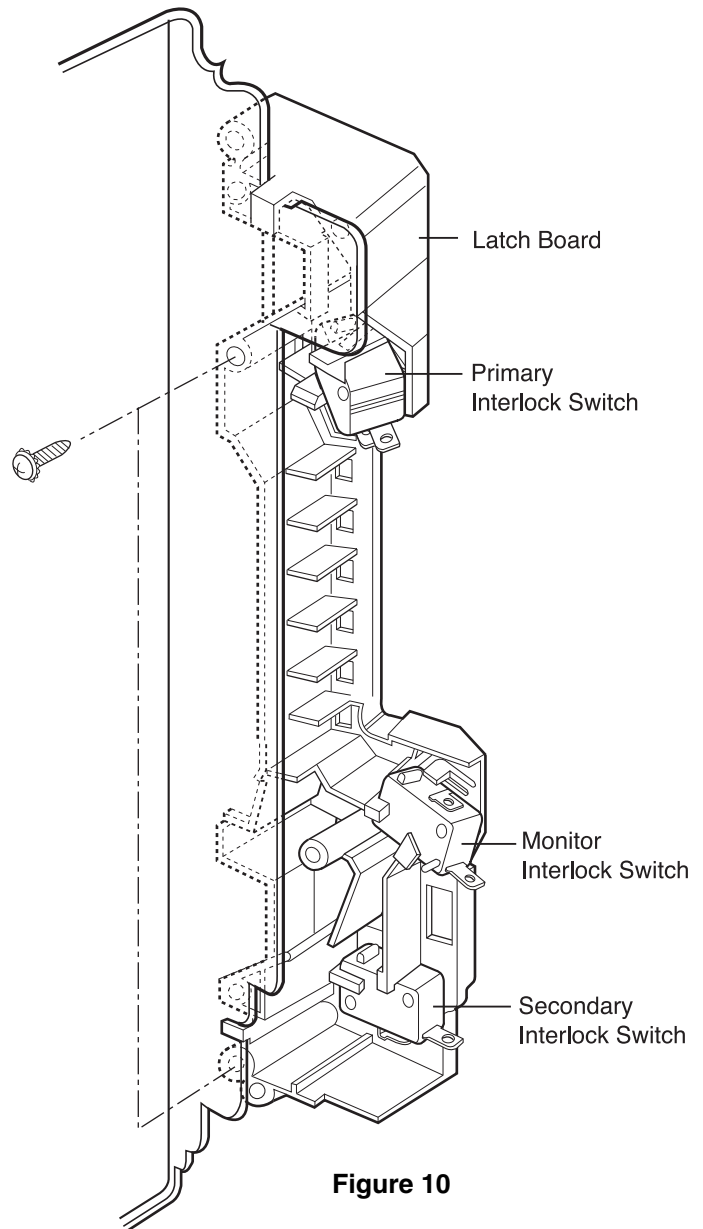

Figure 10

WIRE COLOR

SYMBOL	COLOR
WH	WHITE
BK	BLACK
BR	BROWN
RD	RED
YL	YELLOW
PK	PINK
BL	BLUE
GY	GREY
GN	GREEN
N.P.	Not Provided

D. REMOVING MAGNETRON

(Figures 11 Through 12)

- (1) Remove the vent grill by loosening the one screws.(Figure 11)
- (2) Remove fan bracket and outer case. See page 7-6.
- (3) Remove the four tap tite screws securing the magnetron to the wave guide.
- (4) Disconnect the lead wire.
- (5) Remove the magnetron VERY CAREFULLY.

NOTES:

- When removing the magnetron, make sure that its dome does not hit any adjacent parts, or it may be damaged.
- When replacing the magnetron, be sure to install the magnetron gasket in the correct position and be sure that the gasket is in good condition.
- After replacing the magnetron, check for microwave energy leakage with a survey meter. Checked microwave energy leakage must be below the limit of 5 mW/cm². (All service adjustments should be made for minimum microwave energy leakage readings.)

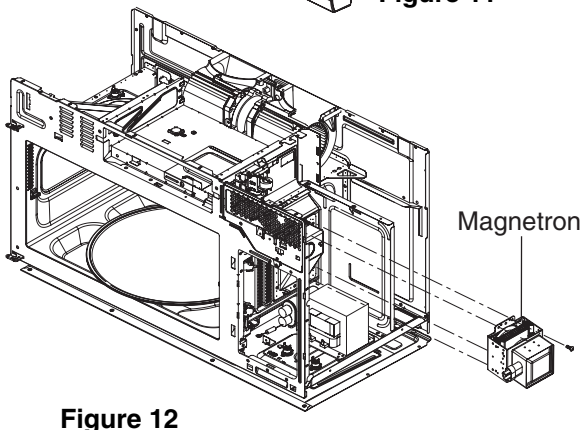
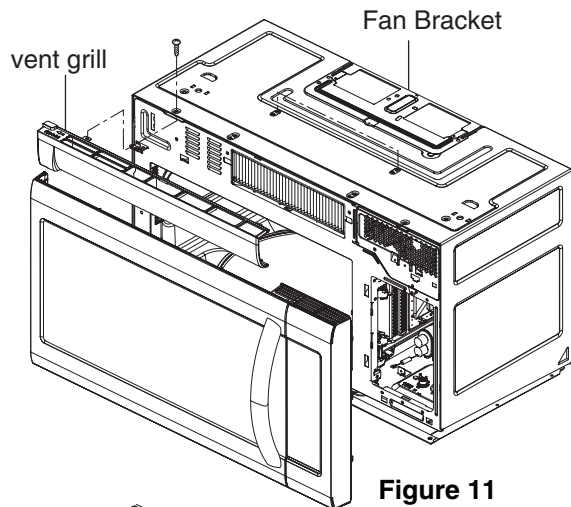

E. REMOVING STIRRER FAN

(Figures 13 and 14)

- (1) Remove one rivet assembly securing it to the oven upper plate by using a knife blade.
- (2) Remove the stirrer fan cover.
- (3) Remove the stirrer fan.

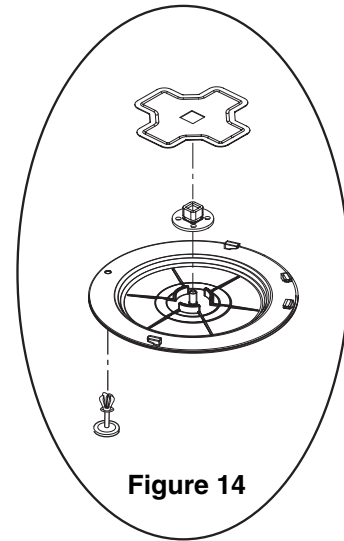
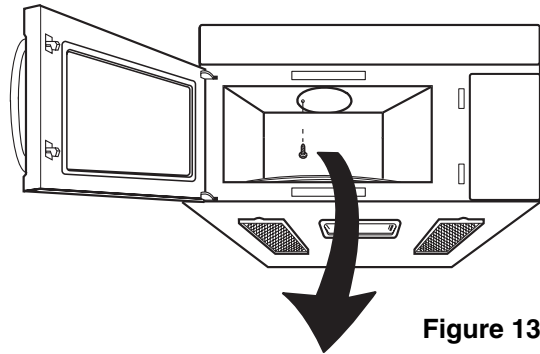

F. REMOVING DOOR (Figure 15)

- (1) Remove the vent grille by loosening the two screws securing it to the outer case.
- (2) Lift up and draw out the door.

NOTES:

- After replacing the door, be sure to check that the primary interlock switch, the secondary interlock switch and the interlock monitor switch are in good operating condition.
- After replacing the door, check for microwave energy leakage with a survey meter. Microwave energy leakage must be below the limit of $5\text{mW}/\text{cm}^2$ (With a 275 ml water load).

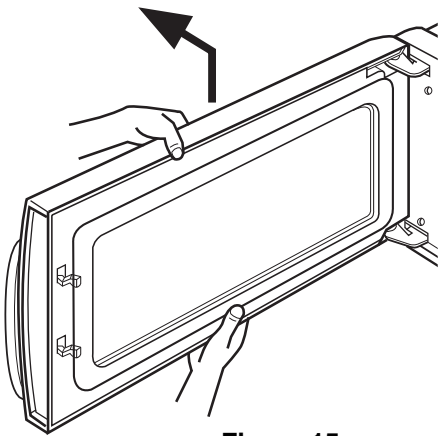

Figure 15

G. DISASSEMBLING DOOR (Figure 16)

- (1) Remove the dielectric choke by using a knife blade or small screwdriver, etc.
- (2) Remove the two screws securing it to the door handle.

CAUTION: Be careful not to damage the door seal plate with the screwdriver.

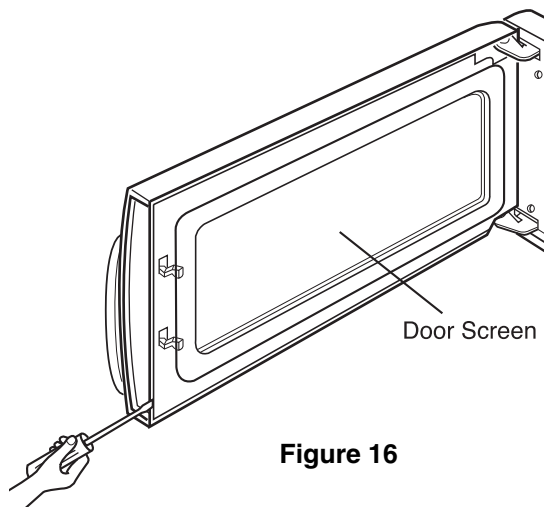
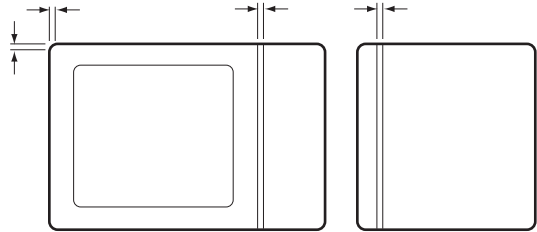

Figure 16

H. ASSEMBLING DOOR

- (1) When mounting the door assembly to the oven assembly, be sure to adjust the door assembly parallel to the chassis. Also adjust it so the door has no play between the inner door surface and oven frame assembly. If the door assembly is not mounted properly, microwaves may leak from the clearance between the door and the oven.



I. REMOVING THE VENTILATION FAN ASSEMBLY

- (1) Remove the two screws securing the fan bracket and the one screw securing the ventilation fan assembly. (See Figure 17-a)

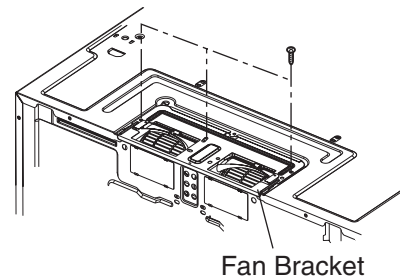

Figure 17-a

- (2) Carefully pull the ventilation motor assembly out of the microwave oven. (See Figure 18-b)

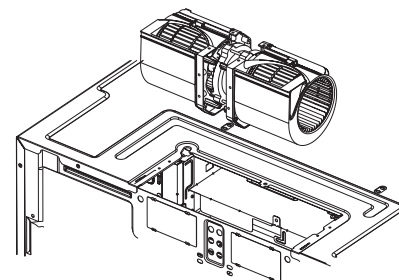

Figure 17-b

J. REMOVING THE TURNTABLE MOTOR

- (1) Remove the glass tray and rotating ring.
- (2) Remove the turntable shaft VERY CAREFULLY with one hand. (Figure 18)
- (3) Remove the base plate by removing the 8 screws securing it to the oven cavity. (Figure 19)
- (4) Disconnect the lead wire from the turntable motor terminals.
- (5) Remove the 1 screw securing the turntable motor to the oven cavity assembly. (Figure 20)

NOTES:

- Remove the lead wire from the turntable motor VERY CAREFULLY.
- Be sure to grasp the connector, not the wires, when removing.

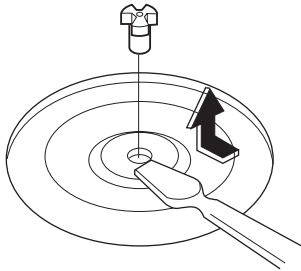

Figure 18

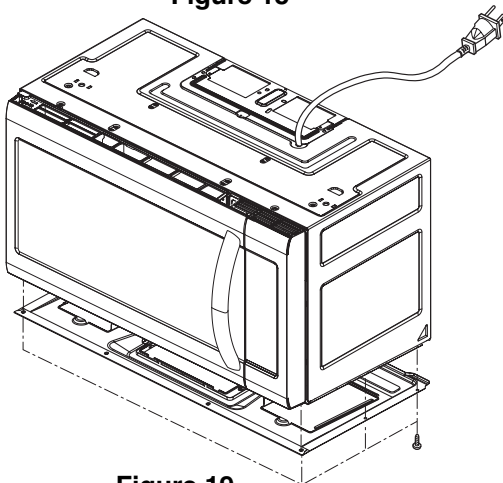

Figure 19

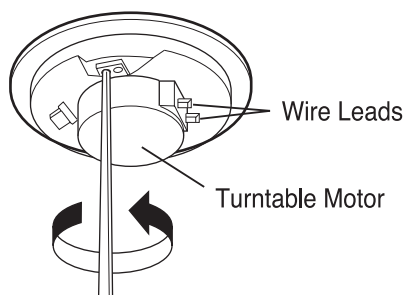

Figure 20

12. EXPLODED VIEW

INTRODUCTION

MODELS:

Customer Model	Product Code	SVC Model
LMV2031SW	MV2094ASD.CWHELGA	LMV2031SW /00
LMV2031SB	MV2094ASD.CBKELGA	LMV2031SB /00
LMV2031ST	MV2094ASDL.CSBELGA	LMV2031ST /00
LMV2031BD	MV2094ASDL.CBDELGA	LMV2031BD /00

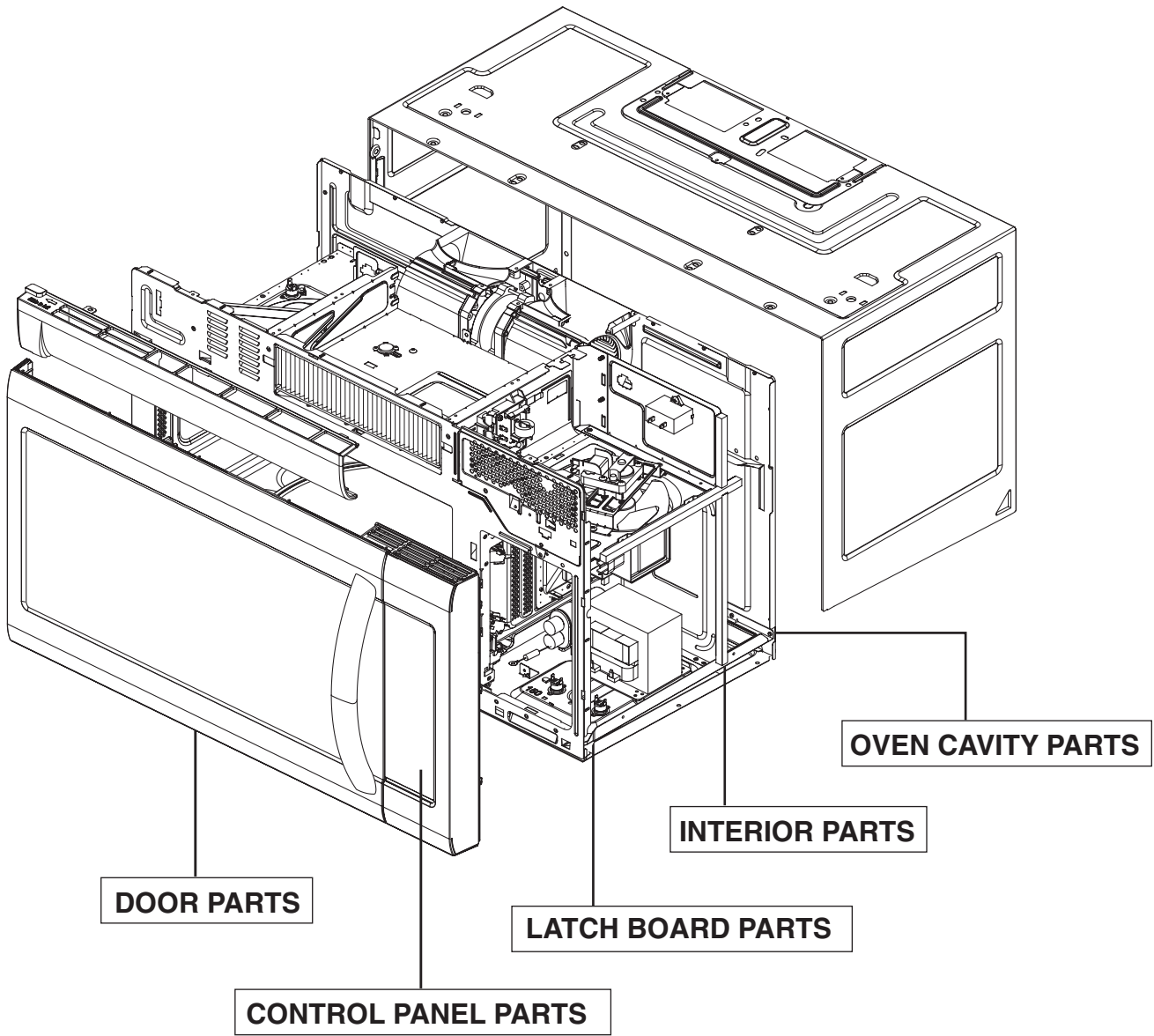

DOOR PARTS

MODELS:

Customer Model	Product Code	SVC Model
LMV2031ST	MV2094ASDL.CSBELGA	LMV2031ST /00
LMV2031BD	MV2094ASDL.CBDELGA	LMV2031BD /00

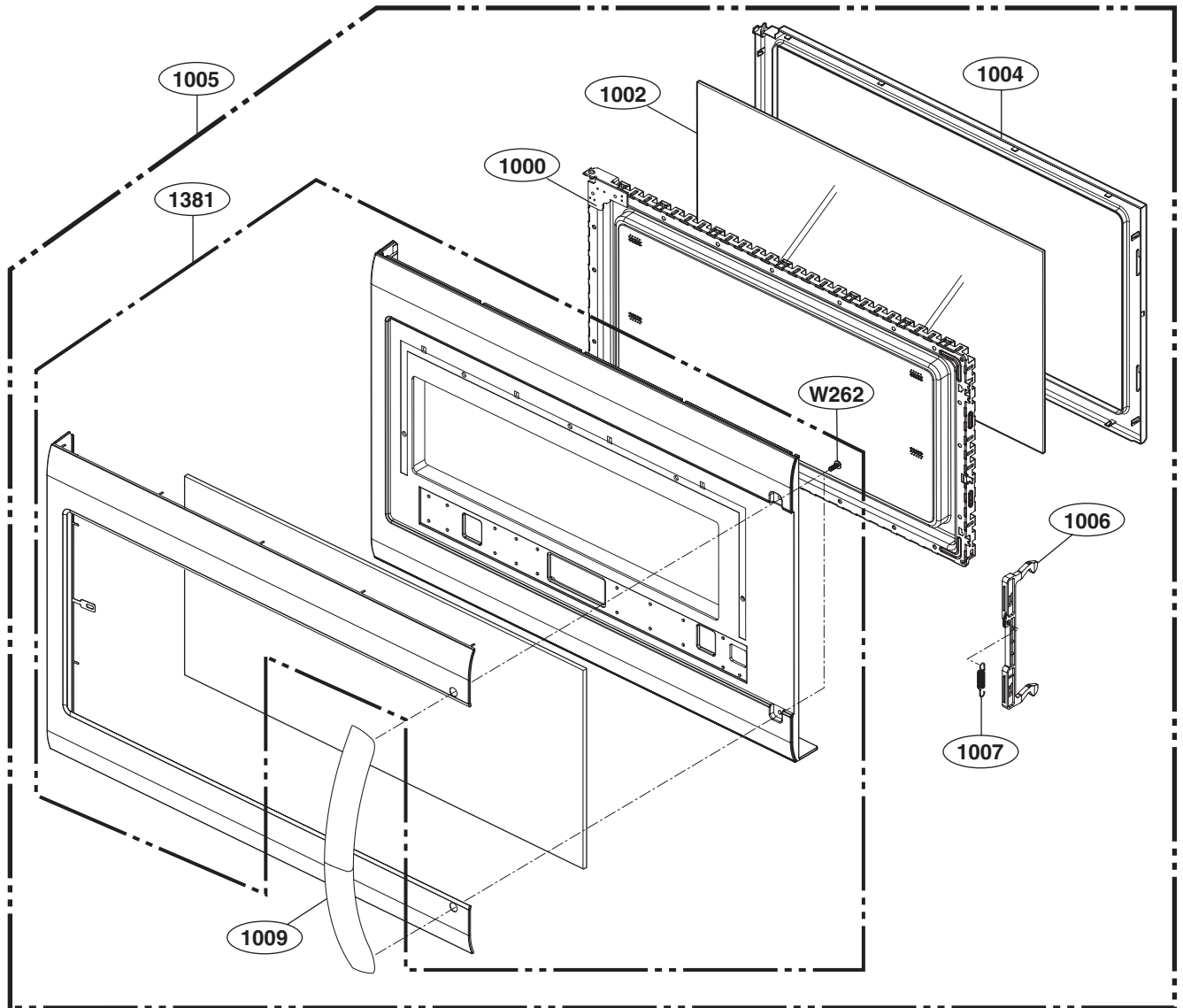

CONTROLLER PARTS

MODELS:

Customer Model	Product Code	SVC Model
LMV2031ST	MV2094ASDL.CSBELGA	LMV2031ST /00
LMV2031BD	MV2094ASDL.CBDELGA	LMV2031BD /00

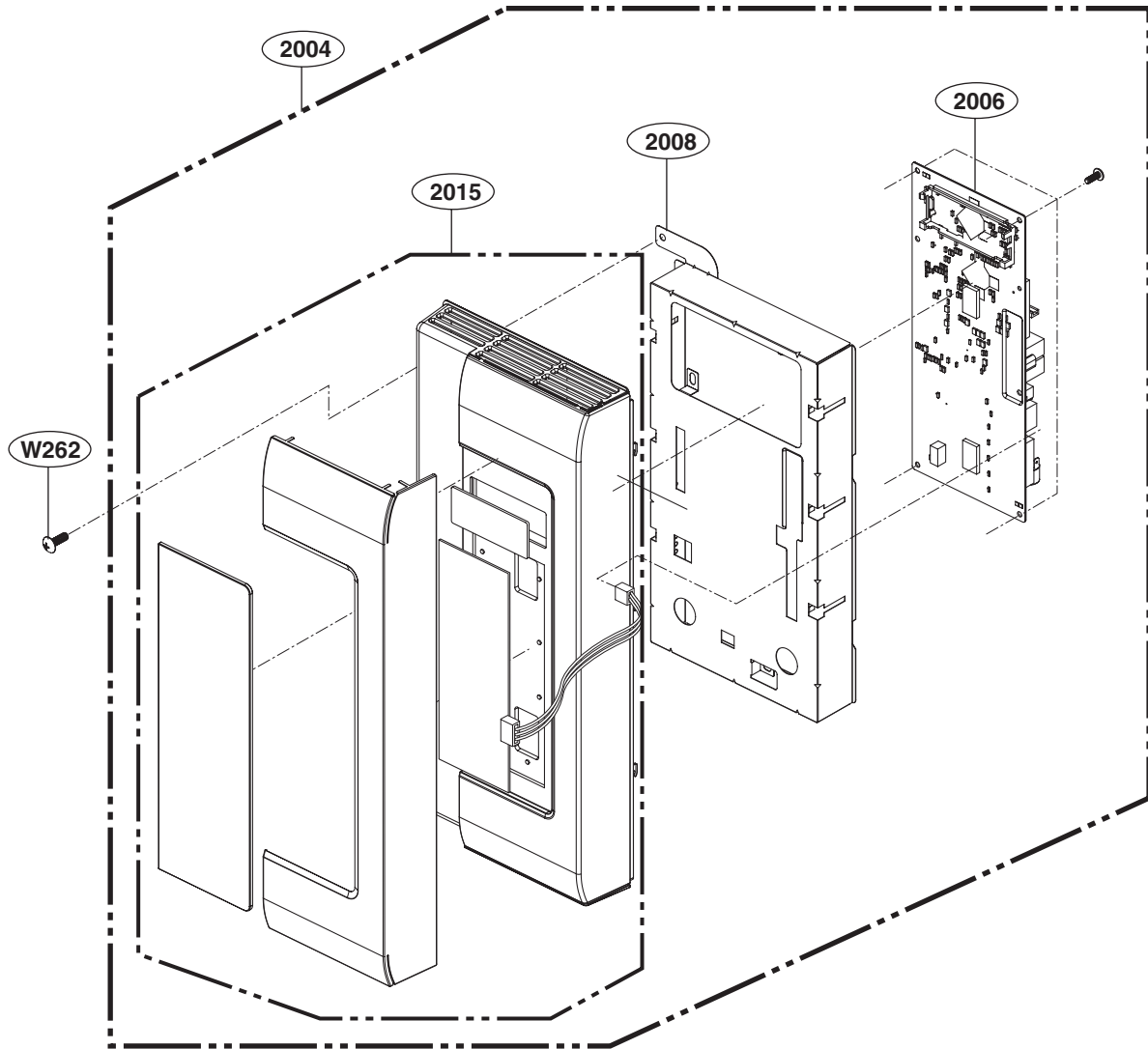

OVEN CAVITY PARTS

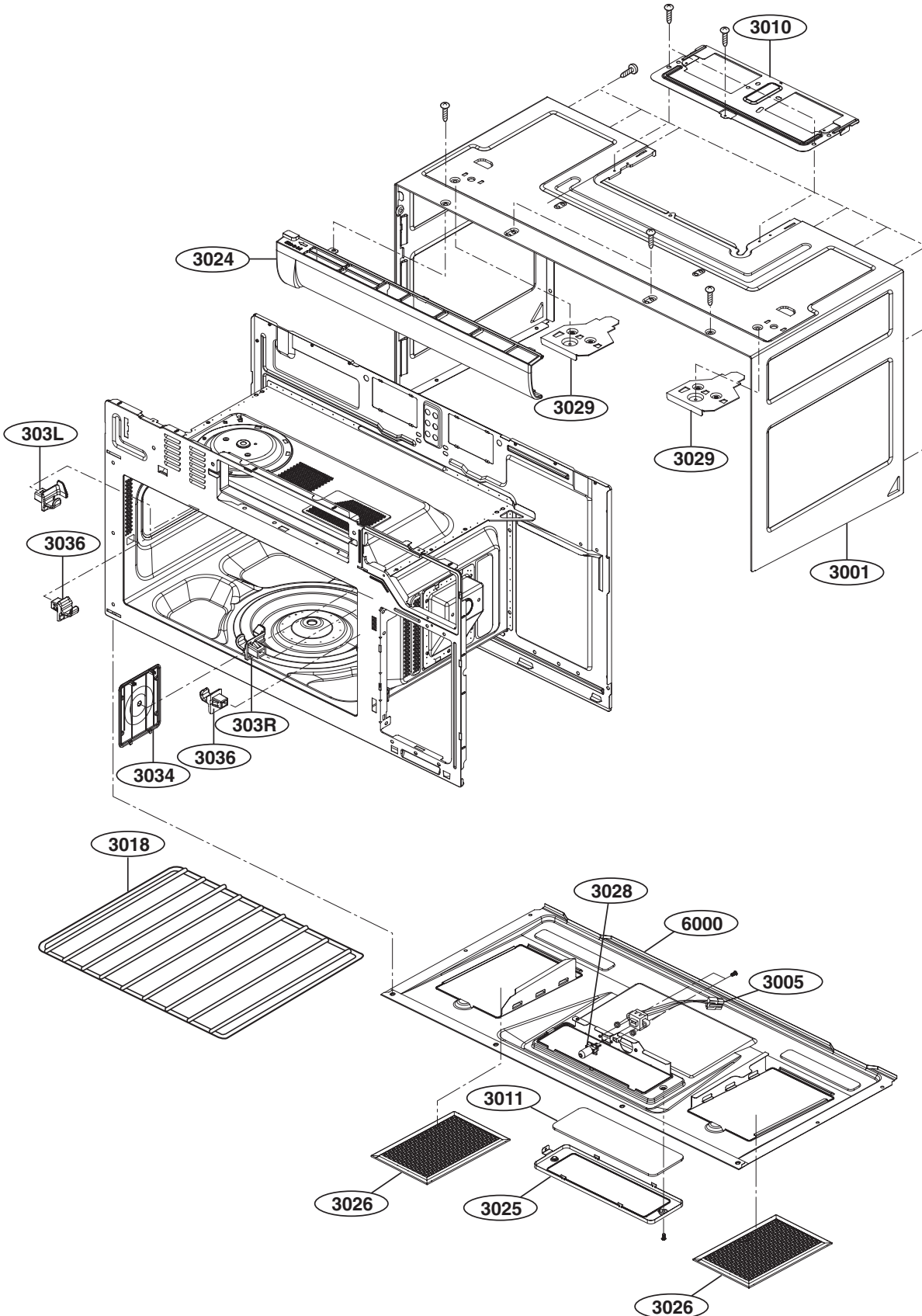

LATCH BOARD PARTS

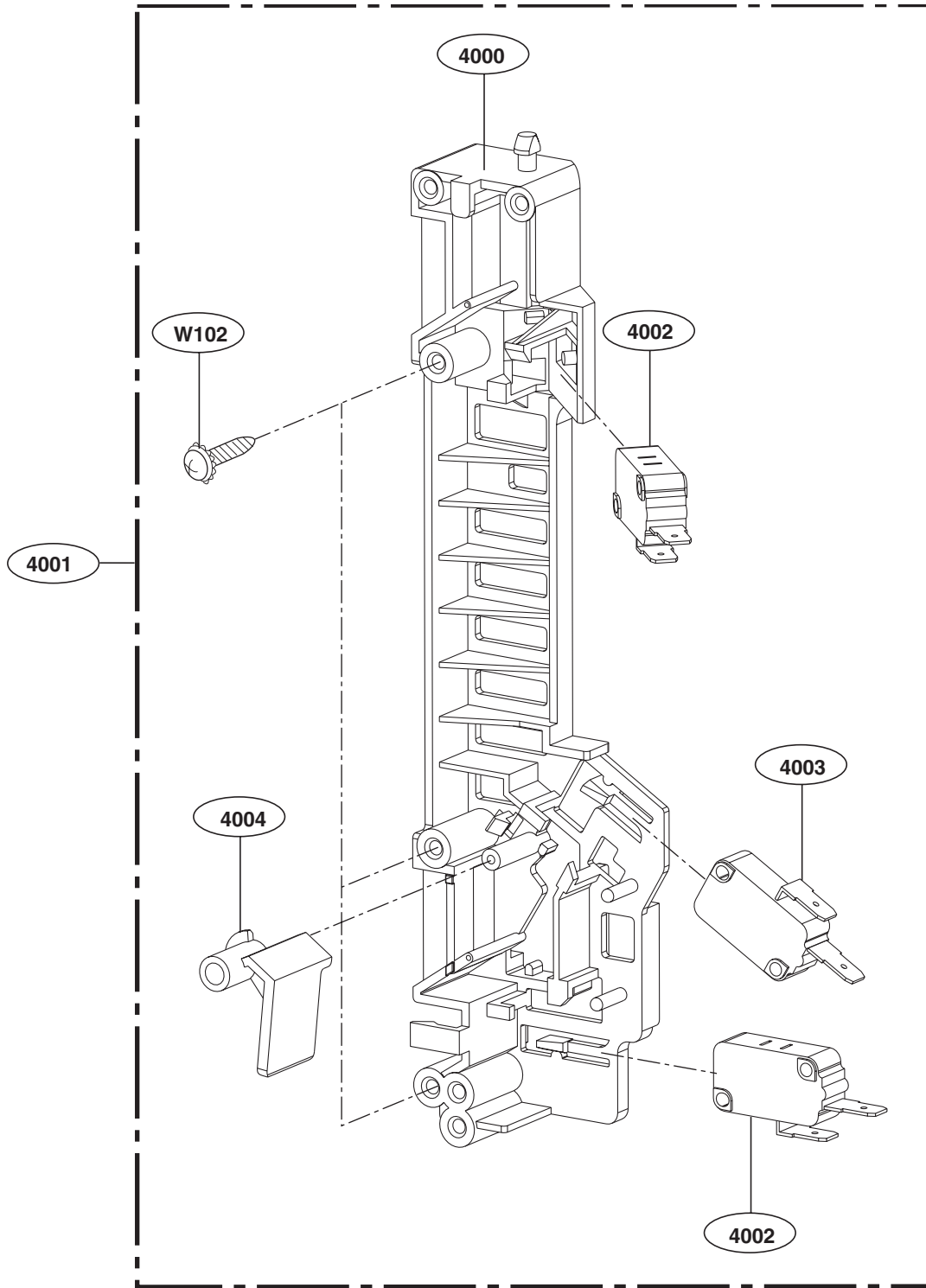

INTERIOR PARTS(I)

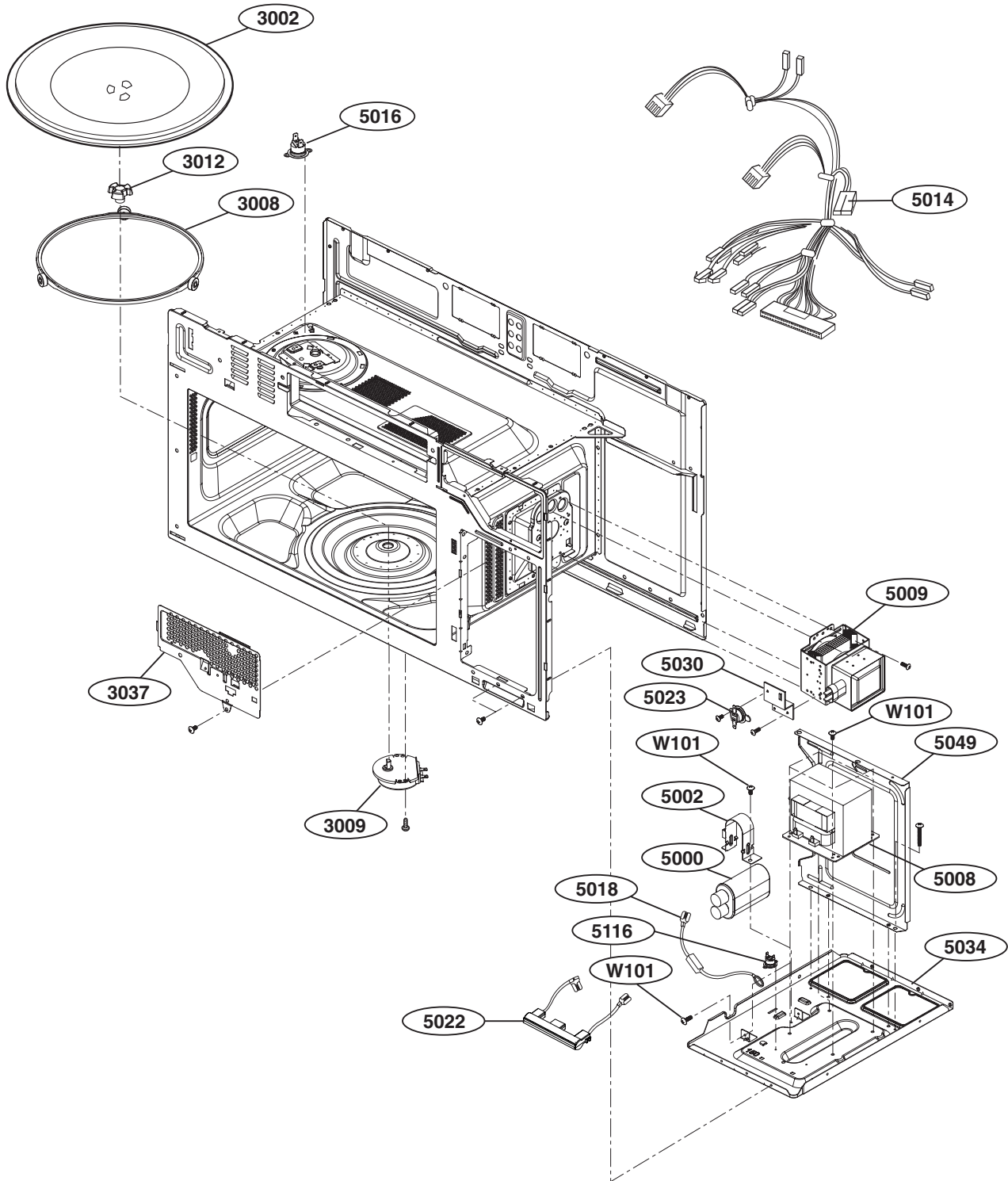

INTERIOR PARTS(II)

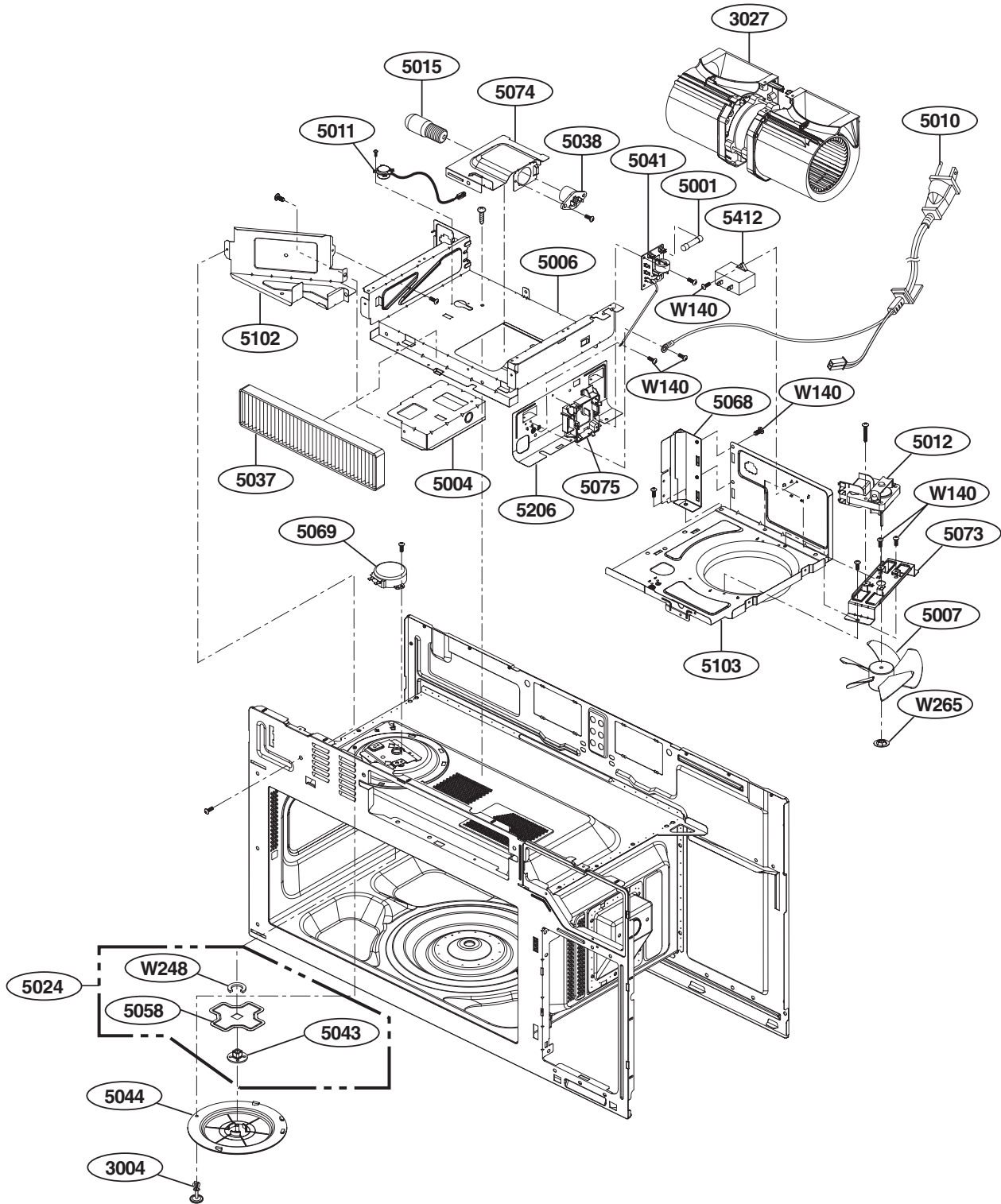

INSTALLATION PARTS

