



CONFIDENTIAL

REFRIGERATOR

SERVICE MANUAL

CAUTION
BEFORE SERVICING THE UNIT,
READ THE SAFETY PRECAUTIONS IN THIS MANUAL.

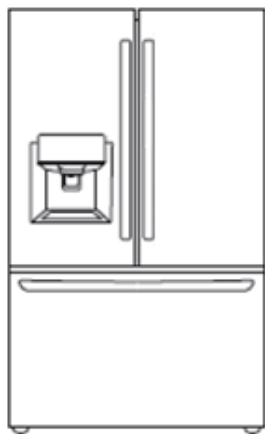

MODEL : LFXS26973*

Any reproduction, duplication, distribution (including by way of email, facsimile or other electronic means), publication, modification, copying or transmission of this Service Manual is STRICTLY PROHIBITED unless you have obtained the prior written consent of the LG Electronics entity from which you received this Service Manual. The material covered by this prohibition includes, without limitation, any text, graphics or logos in this Service Manual.

Copyright © 2016-2017 LG Electronics Inc. All rights reserved. Only training and service purposes

CONTENTS

SAFETY PRECAUTIONS	2
1. SPECIFICATIONS	3
2. PARTS IDENTIFICATION	4
3. DISASSEMBLY	5-18
REMOVING AND REPLACING REFRIGERATOR DOORS	5
DOOR	6
DOOR ALIGNMENT	7
FAN AND FAN MOTOR(EVAPORATOR)	7
DEFROST CONTROL ASSEMBLY	8
MULTI DUCT	8
MAIN PWB	9
DISPENSER	9
DISPLAY PCB	9
ICE BUTTON ASSEMBLY	9
WATER BUTTON ASSMEBLY	10
ICE CORNER DOOR REPLACEMENT	10
ICEMAKER REPLACEMENT	10-11
SUB PWB FOR WORKING DISPENSER	11
CAP DUCT MOTOR REPLACEMENT	11
HOW TO REMOVE A ICE BIN	12
HOW TO INSERT A ICE BIN	12
HOW TO REMOVE AND REINSTALL THE PULLOUT DRAWER	13-14
FAN AND FAN MOTOR DISASSEMBLY METHOD	17
DRAWER REMOVAL	18
4. ADJUSTMENT	19
5. CIRCUIT DIAGRAM	20
6. TROUBLESHOOTING	21
7. PCB PICTURE	22-23
8. TROUBLESHOOTING WITH ERROR DISPLAY	24-37
10. REFERENCE	71-74
11. COMPONENT TESTING INFORMATION	75-81
12. COMPRESSOR TROUBLESHOOTING	82-91
13. ICEMAKER OPEARTING AND TROUBLE SHOOTING METHOD	92-101
14. DESCRIPTION OF FUNCTION & CIRCUIT OF MICOM	101-105

SAFETY PRECAUTIONS

Please read the following instructions before servicing your refrigerator.

1. Unplug the power before handling any elctrical componets.
2. Check the rated current, voltage, and capacity.
3. Take caution not to get water near any electrical components.
4. Use exact replacement parts.
5. Remove any objects from the top prior to tilting the product.

Copyright © 2016 - 2017 LG Electronics Inc. All rights reserved. Only training and service purposes.

1. SPECIFICATIONS

1-1 LFXS26973*

- 26 cu.ft.

ITEMS	SPECIFICATIONS
DOOR DESIGN	Side Rounded
DIMENSIONS (inches)	35 3/4 X 34 7/8 X 69 3/4 (WXDXH) 26.2 cu.ft.
NET WEIGHT (pounds)	128kg(282lb)
COOLING SYSTEM	Fan Cooling
TEMPERATURE CONTROL	Micom Control
DEFROSTING SYSTEM	Full Automatic Heater Defrost
DOOR FINISH	PCM, Stainless
HANDLE TYPE	Bar
INNER CASE	ABS resin
INSULATION	Polyurethane Foam

ITEMS	SPECIFICATIONS	
VEGETABLE TRAY	Clear Drawer Type	
COMPRESSOR	Linear	
EVAPORATOR	Fin Tube Type	
CONDENSER	Spiral Condenser	
REFRIGERANT	R- 600a(56g)	
LUBRICATING OIL	ISO10 (280 ml)	
DEFROSTING DEVICE	SHEATH HEATER	
LAMP	REFRIGERATOR FREEZER	LED Module(18) LED

● DIMENSIONS

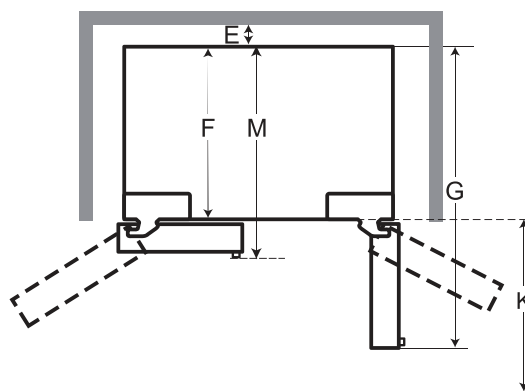
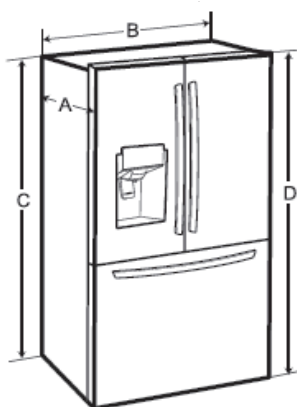

-	List	LFXS6596*/LFXS26556*/LFXS26973*
A	Depth without handle	32 3/8" (822 mm)
B	Width	35 3/4" (908 mm)
C	Height to Top of Case	68 3/8" (1737 mm)
D	Height to Top of Hinge	69 3/4" (1772 mm)
E	Back Clearance	2" (50 mm)
F	Depth without Door	28 1/2" (724 mm)
G	Depth (Total with Door Open 90°)	47 1/8" (1197 mm)
K	Front Clearance	24" (610 mm)
M	Depth With handle	34 7/8" (886 mm)

Refrigerator Interior

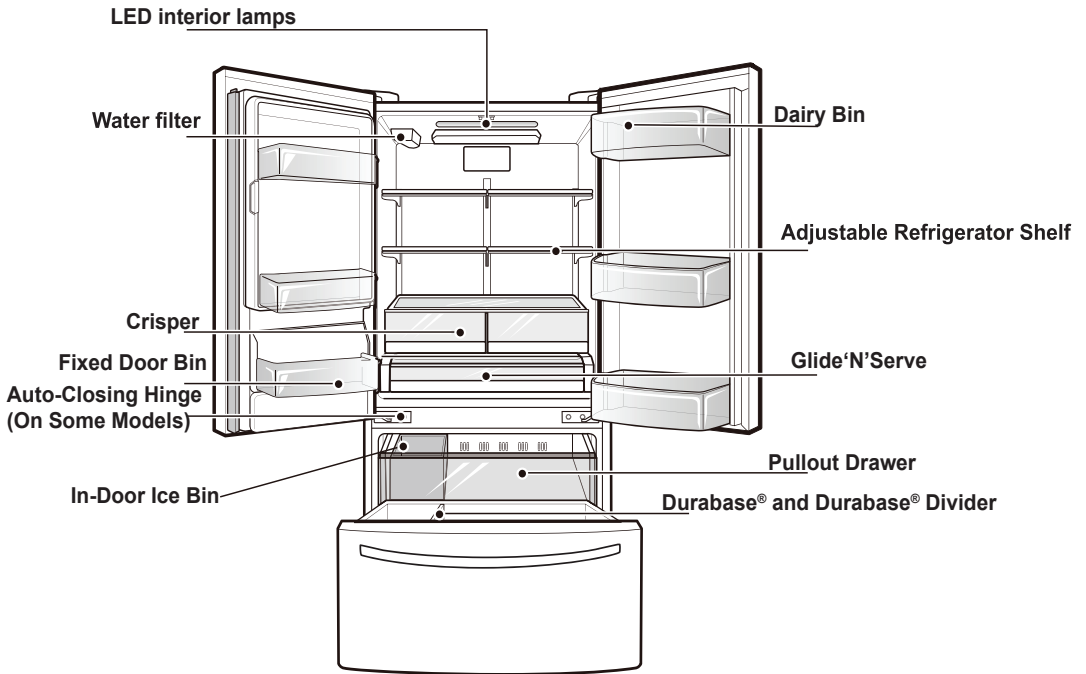

3. DISASSEMBLY

● 3-1 Removing Refrigerator Door

▲ **CAUTION** : Before you begin, unplug the refrigerator. Remove food and bins from doors.

▶ Left Door -FIG. 2

1. Disconnect water supply tube by pushing back on the disconnect ring (4).-FIG. 1
2. Open door. Loosen top hinge cover screw (1).
- Use flat tip screwdriver to pry back hooks on front underside of cover (2). Lift up cover.
3. Disconnect door switch wire harness. Remove cover.
4. Pull out the tube(3).
5. Disconnect the two wire harnesses (4). Remove the grounding screw (5).
6. Rotate hinge lever (6) counterclockwise. Lift top hinge (7) free of hinge lever latch (8).

▲ **CAUTION** : When lifting hinge free of latch, be careful that door does not fall forward.

7. Place door, inside facing up, down onto a non-scratching surface.

▶ Right Door -FIG. 3

1. Open door. Loosen top hinge cover screw (1). Lift up cover (2).
 2. Disconnect door switch wire harness. Remove cover.
 3. Rotate hinge lever (3) clockwise. Lift top hinge (4) free of hinge lever latch (5).
 4. Lift door from middle hinge pin and remove door.
- ▲ **CAUTION** : When lifting hinge free of latch, be careful that door does not fall forward.
5. Place door, inside facing up, down onto a non-scratching surface.

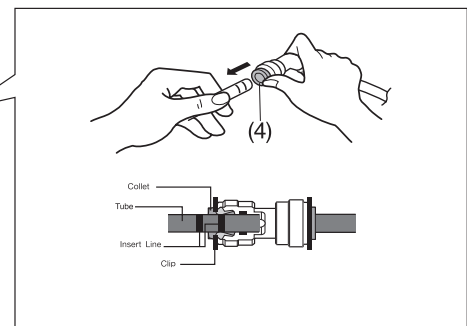
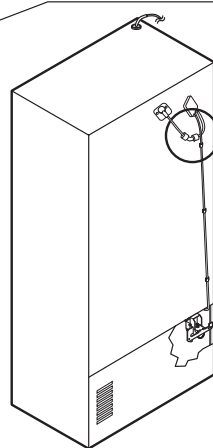
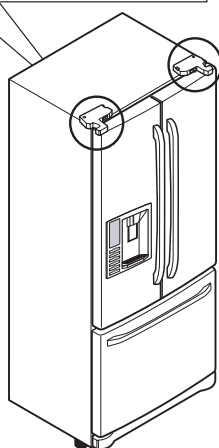
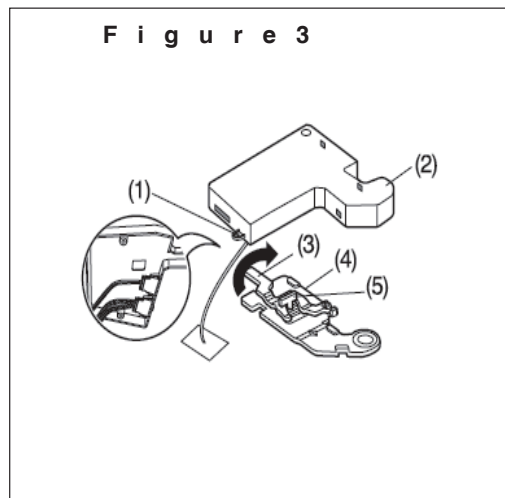
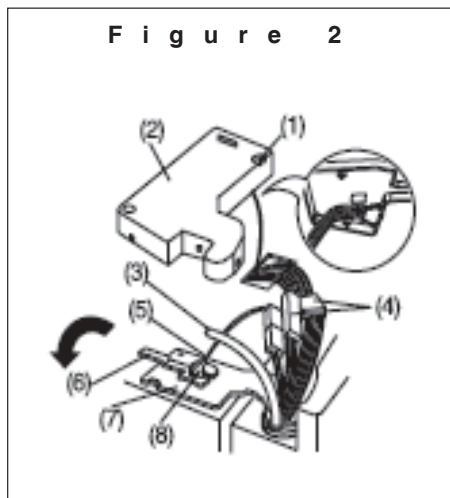

3-2 DOOR

● Mullion Removal

1. Remove 2 screws.

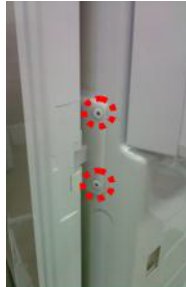

Figure 1

2. Lift Mullion up carefully.



Figure 2

3. Disconnect wire harness.



Figure 3

● Door Gasket Removal

1. Remove gasket

Pull gasket free from gasket channel on the four remaining sides of door.

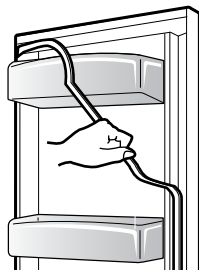

Figure 4

● Door Gasket Replacement

1. Insert gasket into channel

Press gasket into channels on the four remaining sides of door.

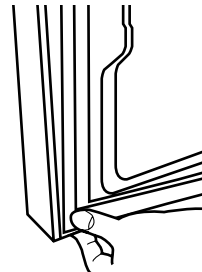

Figure 5

● Mullion Replacement

1. Connect wire harness.



Figure 6

2. Insert mullion into the channel.

Insert the cover assembly into bracket, door.



Figure 7

3. Assemble 2 screws.

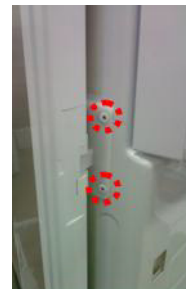

Figure 8

3-3 Sub PCB For Working Dispenser

● Sub,PCB Removal

1. Remove 1 Screw.



2. Lift Sub PCB up carefully.

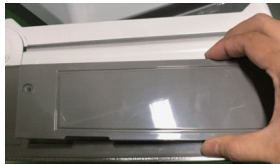

3. Reverse the Sub PCB cover.

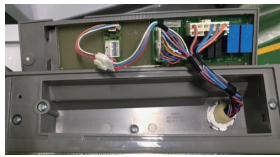

4. Disconnect capacitor housing.

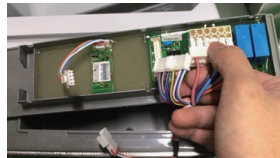

5. Disconnect wire harness.



● Sub,PCB Replacement

1. Reverse the Sub PCB cover.



2. Connect wire harness.



3. Connect the capacitor housing.



4. Insert the Sub PCB sideling.



5. Assemble 1 screw.



3-4 Door Alignment

If the space between the door are uneven, follow the instructions to align them.

Remove the Base Grillie. Turn the leveling legs counter clock wise to raise or clock wise to lower the height of the front of the refrigerator by using flat blade screw driver or 11/32" wrench. Use the wrench (Included with the User Manual) to adjust the bolt in the door hinge to adjust the height. (CCW to raise or CW to lower the height.)

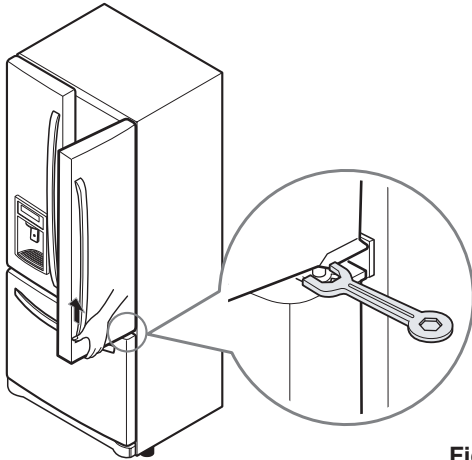

Figure 9

3-5 FAN AND FAN MOTOR(EVAPORATOR)

1. Remove the freezer drawer. (If your refrigerator has an icemaker, remove the icemaker first)
2. Remove the plastic guide for slides on left side by unscrewing phillips head screws.
3. Remove the grille by removing 4 screws and pulling the grille forward.
4. Remove the Fan Motor assembly by loosening 3 screws and disassembling the shroud.
5. Pull out the fan and separate the Fan Motor and Bracket.

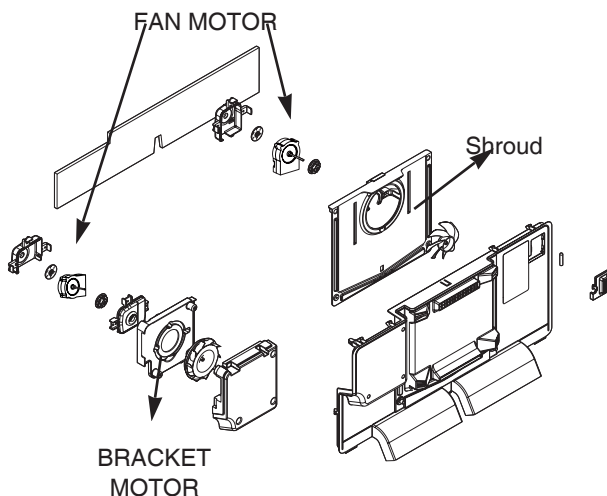

Figure 10

* Ice Fan Scroll Assembly Replacement

- 1) Remove the plastic guide on the left side, using a phillips screwdriver to remove the screws.
- 2) Pull off the sensor cover.
- 3) Remove the grill cover.
- 4) Gently pull on the grill assembly to remove.
- 5) Disconnect the wiring harness.
- 6) Remove all screws on the scroll assembly.



Figure 11

3-6 DEFROST CONTROL ASSEMBLY

Defrost Control assembly consists of Defrost Sensor and FUSE-M.

The Defrost Sensor works to defrost automatically. It is attached to the metal side of the Evaporator and senses its temperature. At 46F(8°C), it turns the Defrost Heater off. Fuse-M is a safety device for preventing over-heating of the Heater when defrosting.

1. Pull out the grille assembly. (Figure 12)
2. Separate the connector with the Defrost Control assembly and replace the Defrost Control assembly after cutting the Tie Wrap. (Figure 13)

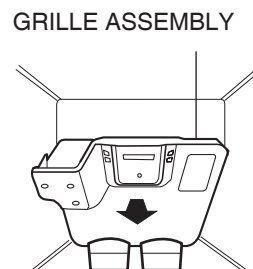

Figure 12

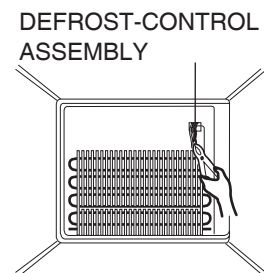

Figure 13

3-7 LAMP

Unplug, or disconnect power at the circuit breaker.
If necessary, remove top shelf or shelves.

3-7-1 Refrigerator Compartment Lamp

1) Pull out cover lamp as using sharp-edged tool.



Figure 14

2) To remove the LED assembly.



Figure 17

LED Assembly

3-7-2 Cap Decor LED LAMP(Bottom)

1. Unplug refrigerator power cord from electric outlet.
2. Open the refrigerator door to need disassembly.
3. Put flat screwdriver into service hole, remove the cover of cap decor LED LAMP.



4. Remove the LED assembly from connector.



5. Replace LED assembly.



6. Assembly the cover in reverse order.

3-8 MULTI DUCT

1. Remove the screw at the Center of Duct Multi
2. Remove the screw and cover filter
3. Disconnect the lead wire on the bottom position

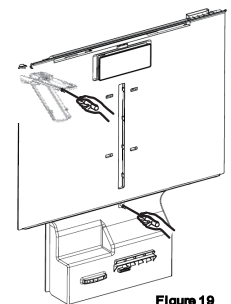

Figure 19

3-8 MAIN PWB

- 1) Loosen 3 screws on the PWB cover.



Figure 20

- 2) Remove the PWB cover



Figure 21

- 3) Disconnect wire harness and replace the main PWB in the reverse order of removal.



Figure 22

3-9 DISPLAY PCB



Fixing HOOK



1. Hold the right side of the Display and pull to the inner diagonal angle to separate.

2. After completely separating the Display from the door, separate 3 points of Wire Housing.



3. Assemble in the reverse order of the disassembly, and assemble while maintaining the horizontality of the Display. After the assembly, to bind 3 Hooks at the top of the Display, lightly hit "tok-tok-tok" with fist.



- ※ CAUTION
Display shall be combined after checking if the length of the Wire Housing at the right side of the Display is too long to cause interference after arranging Wire inside.



3-10 ICE CORNER DOOR REPLACEMENT

- 1) Loosen the front screw as shown in the picture.
- 2) Lift up the hinge with one hand.
- 3) Pull out the Ice Corner Door with the other hand.

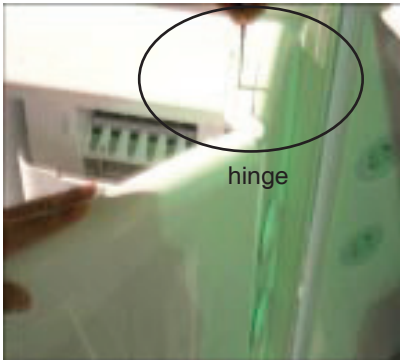

Figure 32

- 3) Disconnect wire harness from wall of compartment.

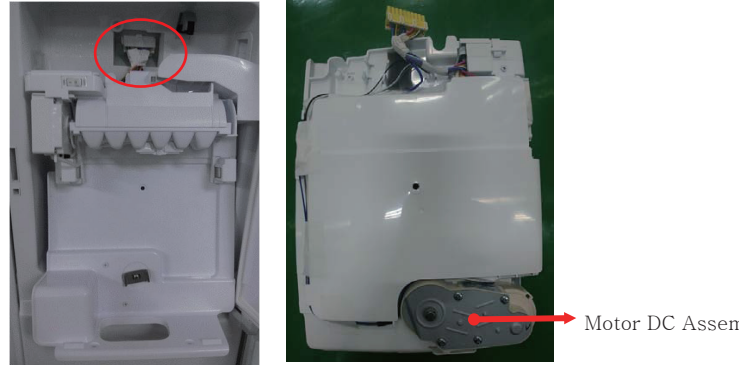

Figure 35

3-11 ICEMAKER REPLACEMENT

- 1) Remove 4 screws as shown.

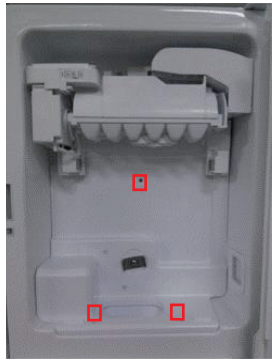

Figure 33

- 2) Grasp the bottom of motor cover assembly and pull slowly.



Figure 34

▲ CAUTION: Make sure that the motor housing is taped to the mold, if not positioned correctly the cover will not fit properly.



Figure 36

3-12 CAP DUCT MOTOR REPLACEMENT

1) Separate the Housing of the Cap Duct Motor.



Figure 39

2) Unscrew 3 screws to disassemble the motor.



Figure 40

3) When replacing the motor, check the position of the door duct and the link for proper fit.

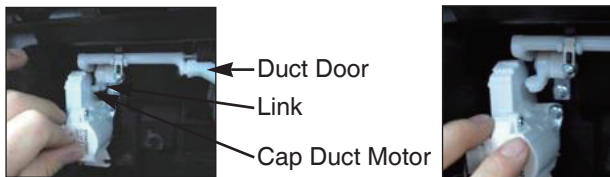

NG Position

Figure 41

4) Insert 2 screws.

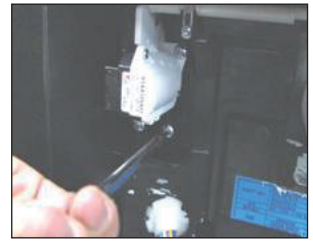

Figure 42

5) Push housing aside.



Figure 43

3-17 HOW TO REMOVE A ICE BIN

1) Grip the handles, as shown.

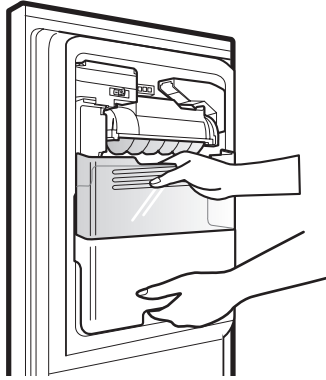

Figure 44

2) Tilt and lift slightly as shown.

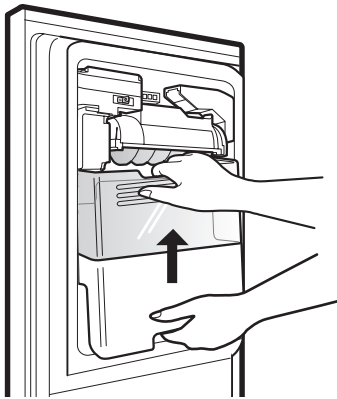

Figure 45

3) Remove ice bin slowly.

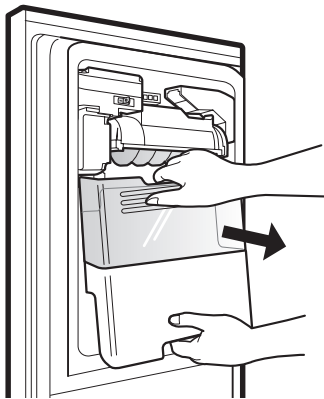

Figure 46

3-18 HOW TO INSERT A ICE BIN

1) Insert the Ice Bin, slightly tilting to avoid touching the Icemaker. (Especially, Ice-Detecting Sensor)

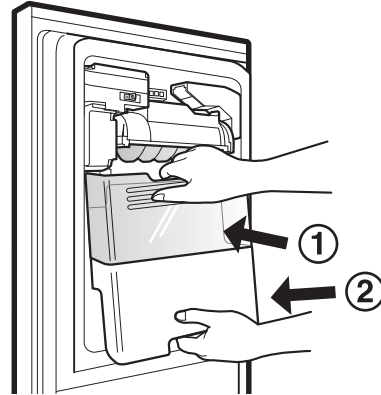

Figure 47

3-19 HOW TO REMOVE AND REINSTALL THE PULLOUT DRAWER

3-19-1 Follow Steps to Remove

Step 1) Open the freezer door.



Step 2) Remove the lower basket.



Step 3) Remove the two screws from the guide rails (one from each side).

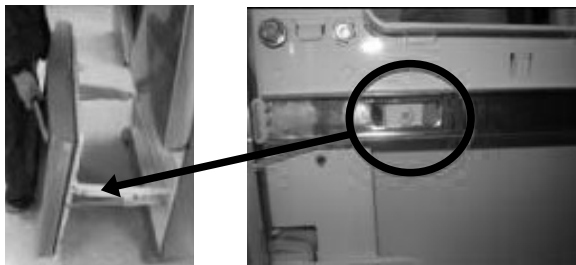

Step 4) Removal of the freezer door is done by lifting clear of the rail support.
Fully extend both rails.



Step 5) Remove only 1 screw of gearice, and disassemble the bar and gearice



Step 6) Remove 2 screws of both side of supporter covers tv and disassemble the supporter cover tv.



3-19-2 Follow Steps to Reinstall

Step 1) Insert both side of supporter cover tv into connector rails, and then screw them.



Step 2) ① Assemble a bar and gear ice with screw.
② Push the otherside of the gear to inside of the bar.

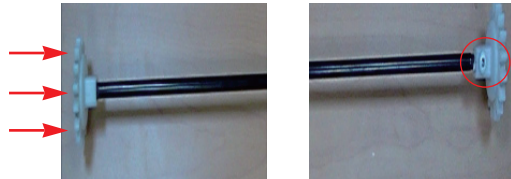

Step 3) Put gear ice assembled with the bar by screw into connector rail's hole.



Step 4) Insert opposite gear ice into connector rail and screw them



Step 5) The rail system will align itself by pushing the rails all the way into the freezer section. Pull the rails back out to full extension.

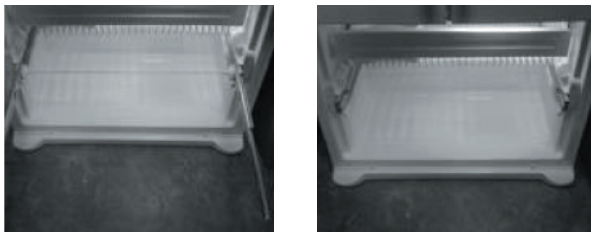

Step 6) Reinstall the freezer door by inserting the rail tabs into the guide rail.



* Assemble them like as pictures



Step 7) Reinstall the two screws into the guide rails (one from each side).

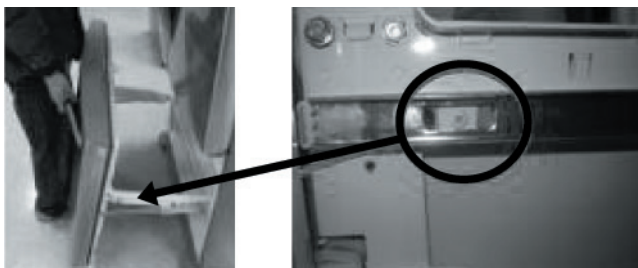

Step 8) Reinstall the lower basket, and close the freezer door.



3-21 WATER VALVE DISASSEMBLY METHOD

- 1) Turn off the water to unit. Remove the waterline from the valve.

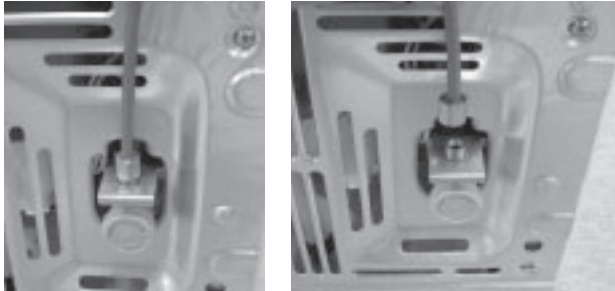

Figure 60

- 2) Remove cover and 1 screw from the valve.

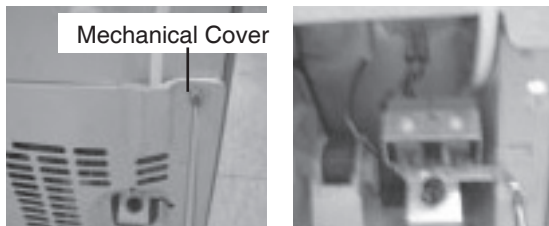

Figure 61

- 3) Separate the housing and remove the valve.



Figure 62

- 4) Remove the clip, and press the collet to separate the tube from the connector. Note: there maybe some water in the line.

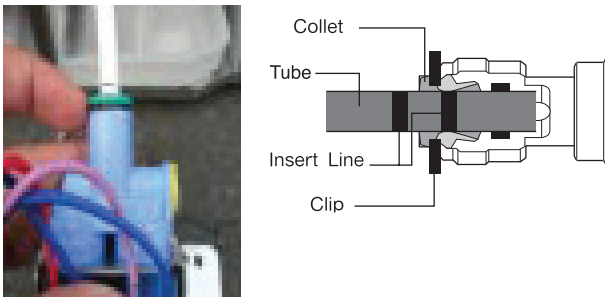

Figure 63

3-22 Fan motor assembly disassembly method

- 1) Remove screws for the Drain Pipe Assembly and the 1 connected to the Motor Cover.



- 2) Remove the screw from shroud and Separate the Fan motor assembly and Shroud.



Assemble in reverse order. Taking care to avoid.

1. Do not to bend the tube during assembly.
2. Press the Water Dispenser button letting water pour out, this checks for any leaks in the tube connection, this may vary depending on the water pressure (about 2 minutes.).

3-23 Drawer Removal

Fully extend the drawer and lift from the front pulling straight out.

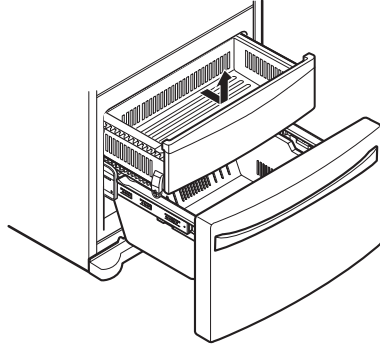

Figure 66

To install the drawer back into the frame, tilt the front slightly and pushing back into place.

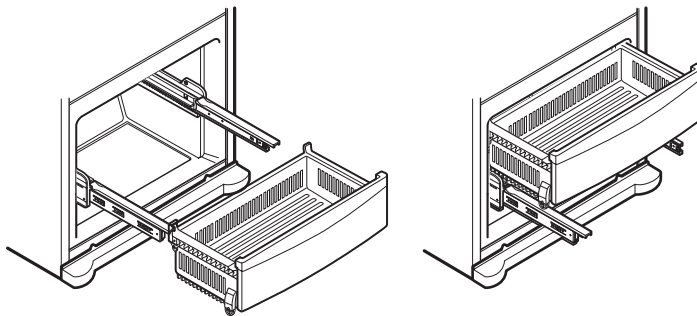

Figure 67

Chapter 13 How to disassemble and assemble the vegetable box

1. Cover TV service method (GC-J288***)

How to disassemble and assemble the vegetable box

How to disassemble vegetable box

- 1 While the refrigeration chamber doors are open wide, remove all of the Magic Space cover and shelves. (Refer to page 27~28)

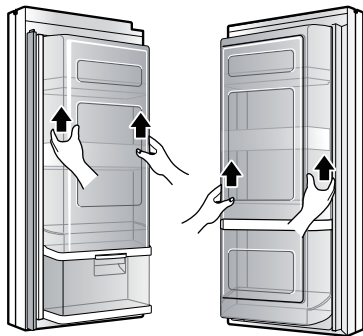

- 2 Remove left/right side vegetable chambers

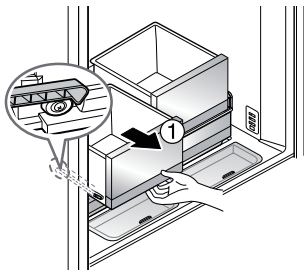

- 3 Support the bottom of the shelf with one hand and hold the front of the vegetable chamber with the other hand, and pull forward about 3cm while lifting the chamber so that the inner side fixing part can be taken out.

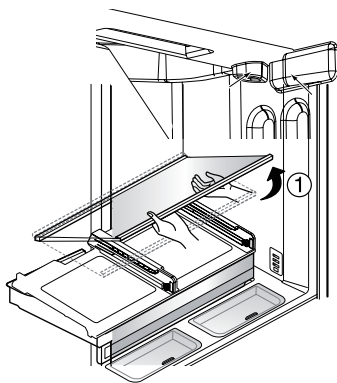

- 4 Take out the vegetable chamber shelf by laying it down 45°.

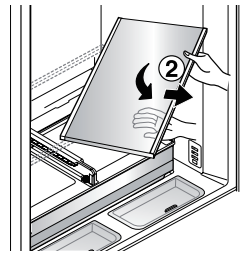

- 5 While lifting the front side of the vegetable chamber tray by 15°, take out forward 10cm so that it is fallen apart from the backside fixing part.

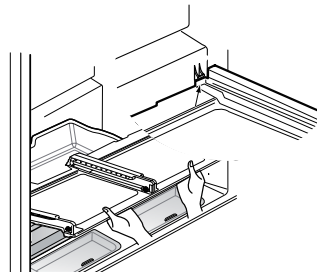

- 6 Erect the tray by 45° or more and slowly take it outside.

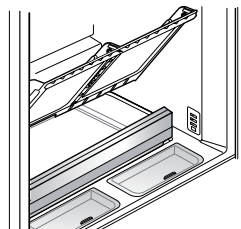

4. ADJUSTMENT

4-1 COMPRESSOR

4-1-1 Role

The compressor intakes low temperature and low pressure gas from the evaporator of the refrigerator and compresses this gas to high-temperature and high-pressure gas. It then delivers the gas to the condenser.

4-1-2 Note for Usage

- (1) Be careful not to allow over-voltage and over-current.
- (2) Do not drop or handle carelessly.
- (3) Keep away from any liquid.
If liquid such as oil or water enters the Cover PTC Compressor may fail due to breakdown of their insulating capabilities.
- (4) Always use the Parts designed for the compressor and make sure it is properly attached to the compressor. Parts may appear physically identical but could have different electrical ratings. Replace parts by part number and model number. Use only approved substitute parts.

4-1-3 Remove the cover PTC



(1) Remove the Cover Back M/C



(2) Loosen two screws on comp base



- (3) Use a L-shaped flap tool to pry off the cover
- (4) Assembly in reverse order of disassembly

4-2-3 Compressor protection logic

- Since linear Comp conducts linear reciprocating motion, we have protection logic for compressor, motor and PCB as the below.

- Stroke Trip
During the operation, if stroke is above the target value, decrease the target volt by 3V.
- Current Trip
Current trip is set in order to protect compressor mechanical part and drive from the overcurrent that might arise during the operation.
Check the current for every 416.7us and if the Trip exceeds 1.86Arms more than three times at Comp ON, forcibly stop and restart six minutes later.
- Lock Piston Trip
If stroke is under 5mm even if the current is more than 14Arms, Take it as 'piston lock' and restart after 2'30" of Comp OFF. Check the current and stroke for every 416.7us and if the condition fits more than three times at Comp ON, the Trip occurs.
- IPM fault Trip
It occurs if FO signal received from IPM is LOW. For every 416.7us, check whether FO signal is LOW. The trip occurs if it is found three times during the five periods(83ms).

5. CIRCUIT DIAGRAM

MEZ66414024 (Label,Circuit)

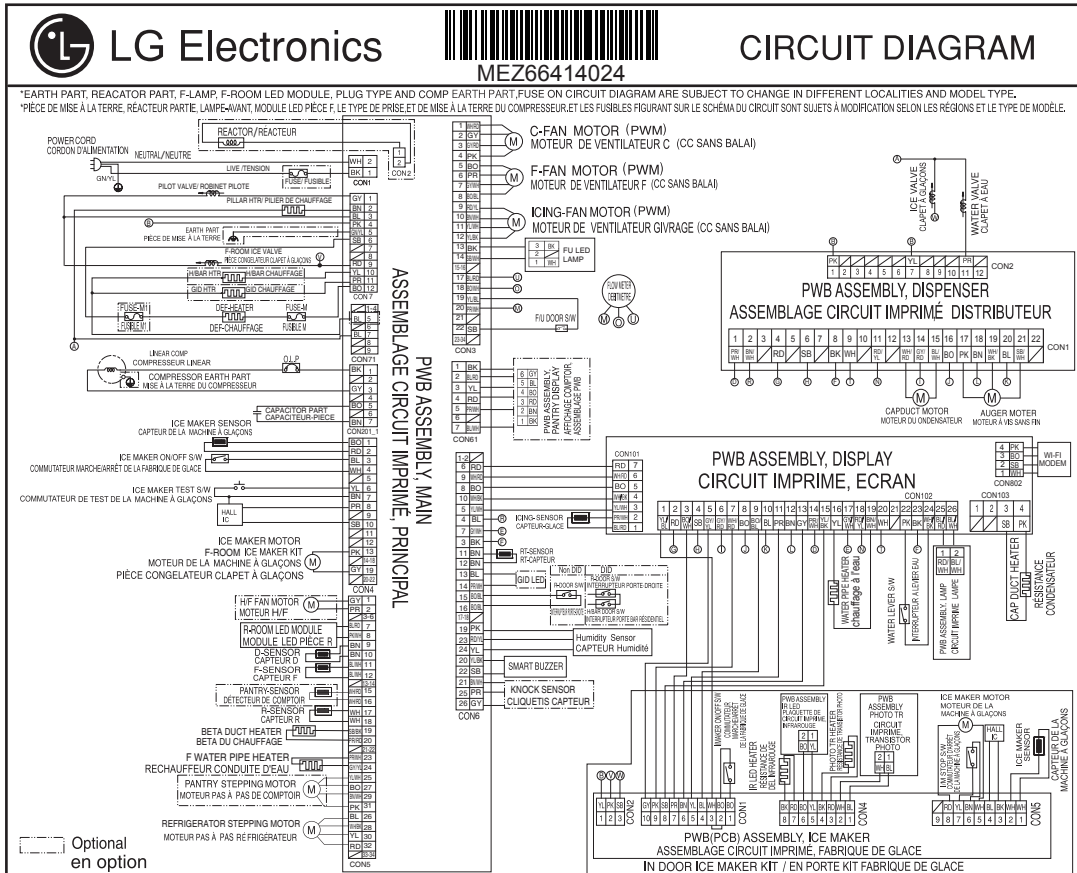

Automatic Icemaker Water Line Hookup/Conexión de la Fábrica de Hielo a la tubería de agua /Raccordement d'une conduite d'eau à la machine à glaçons automatique.

- | Important | Importante | Important |
|--|---|--|
| <ol style="list-style-type: none"> In order to prevent possible leakage resulting in property damage be sure to: <ul style="list-style-type: none"> • Use Designated Tubing • After installation check for leaks. • It may take up to 24 hours for your icemaker to begin producing ice. • If operating the refrigerator before installing the water connection, turn icemaker to the OFF (O) position to prevent operating it without water. • All installations must be in accordance with local plumbing code requirements. • Consult Use and Care Guide for further information The icemaker needs to be connected to a cold water line with water pressure between 20-120psi. If a problem occurs, call your utility company. Do not install the icemaker tubing in areas where temperatures fall below freezing. | <ol style="list-style-type: none"> Para prevenir fugas, que pudieran causar daños de su propiedad, asegure de: <ul style="list-style-type: none"> • Usar tubería designada. • Después de la instalación verifique si hay fugas. • Puede tomar más de 24 hrs para que su fábrica de hielo comience a producir hielo. • Si comienza a usar el refrigerador antes de instalar la conexión de agua, apague la fábrica de hielo OFF (O), para prevenir usarla sin agua. • Toda instalación debe estar acorde con los requerimientos de su plomería local. • Consulte su guía de Uso y Cuidado para más información. La fábrica de hielo necesita estar conectada a una fuente de agua fría con presión entre 20-120psi. Si ocurre algún problema llame a su compañía de servicio público. No instale la tubería de la máquina de hielo en zonas donde las temperaturas descienden por debajo del punto de congelación. | <ol style="list-style-type: none"> Afin de s'éviter des fuites pouvant entraîner des dommages matériels, veillez à : <ul style="list-style-type: none"> • utiliser une tuyauterie adaptée ; • rechercher des traces de fuite après avoir terminé l'installation ; • noter que votre appareil peut avoir besoin de 24 heures avant de pouvoir fabriquer des glaçons ; • pousser le bouton de la machine sur OFF (O) [ARRÊT] lorsque vous mettez déjà le réfrigérateur en marche sans avoir branché l'eau (pour éviter que l'appareil ne tourne à vide) ; • ce que toutes les installations soient conformes aux règles du code de plomberie ; • consulter le Guide d'utilisation et d'entretien pour de plus amples informations ; La machine à glaçons a besoin d'être raccordée à une conduite d'eau froide avec une pression d'eau entre 1,3 et 8,2 bar. En cas de problèmes, prenez contact avec la société de service en charge. Ne pas installer les tuyaux de la machine à glaçons dans les zones où la température descend en dessous de zéro. |

Connecting to refrigerator Conexión al refrigerador Branchement au réfrigérateur

<ol style="list-style-type: none"> Unplug the refrigerator or disconnect power. Attach the copper tube to the valve inlet using a compression nut and sleeve as shown. Finger tighten the compression nut onto valve and then tighten another half turn with a wrench. Use the tube clamp on the back of the refrigerator to secure the tubing to the refrigerator as shown. This will help to prevent damage to the tubing when the refrigerator is pushed back against the wall. Turn water supply valve ON. Check for leaks. Tighten all the connections (including connections at the valve) or nuts that leak. Plug in the refrigerator or reconnect power. Set the icemaker power switch to the ON (I) position. The icemaker will not begin to operate until it reaches its operating temperature of 15°F (-9°C) or below. <p>NOTE 1: If local water conditions require periodic cleaning a strainer should be installed in the 1/4-inch water line. Obtain a water strainer from your nearest appliance dealer.</p> <p>NOTE 2: The hookup line can not be white, plastic tubing. Licensed plumbers must use only copper tubing NDA tubing #49595 or #49599 or Cross Link Poly-ethylene (PEX) tubing.</p>	<ol style="list-style-type: none"> Desconecte el refrigerador o desconecte la electricidad. Fije la tubería de cobre a la entrada de la válvula usando una tuerca de compresión como se muestra. Apriete la tuerca de compresión sobre la válvula y después de otra media vuelta con una llave. Use la abrazadera para tubo (atrás del refrigerador) para asegurar la tubería del refrigerador, como se muestra. Esto ayudará a prevenir daños a la tubería cuando el refrigerador sea empujado contra la pared. Encienda la Fuente de agua. Verifique si hay fugas. Apriete todas las conexiones (Incluyendo las conexiones de la válvula) o las tuercas que fugaron. Conecte el refrigerador o reconecte la electricidad. Cambie el interruptor de la fábrica de helos a la posición de encendido ON (I). La fábrica de helos comenzará a funcionar hasta que alcance la temperatura de 15°F (-9°C) o menos. <p>NOTA 1: Si las condiciones de agua locales requieren limpieza periódica o si su fuente de agua es insegura, se deberá instalar un filtro de agua en la línea de agua de 1/4 de pulgada. Puede obtener un filtro de agua con su distribuidor más cercano.</p> <p>NOTA 2: La línea de conexión no puede ser blanca de plástico. Plomeros con licencia deberán usar sólo tubería de cobre Tubería NDA #49595 ó #49599 o tubería reticulada de Polietileno (PEX).</p>	<ol style="list-style-type: none"> Débrancher le réfrigérateur ou mettre l'appareil hors tension. Fixer le tuyau en cuivre à la vanne d'arrivée d'eau à l'aide d'un écrou de compression et d'un manchon (voir schéma). Serrer avec le bout des doigts l'écrou de compression sur la vanne puis resserrer avec une clé encore d'un demi-tour. Utiliser l'écrou de serrage pour tuyau pour l'arrière du réfrigérateur afin de fixer le tuyau au réfrigérateur (voir schéma). Cela va permettre d'éviter que le tuyau ne soit abîmé lorsque le réfrigérateur est poussé vers le mur. Tourner la vanne d'alimentation en eau sur ON (MARCHÉ). Vérifier qu'il n'y a pas de fuites. Resserrer tous les raccords (y compris ceux à la vanne) ou écrous qui présentent des traces de fuites. Rebrancher le réfrigérateur ou remettre sous tension. Régler la machine à glaçons sur la position ON (I) (MARCHÉ). La machine à glaçons ne va pas fonctionner tant que la température de l'appareil en service n'aura pas atteint 9°C ou moins. <p>NOTE 1 : Si la qualité de l'eau a pour effet qu'il faut procéder régulièrement à un nettoyage, vous devez placer un filtre dans la conduite d'eau à environ 1/2 cm du bord. Procurez-vous un filtre à eau auprès de votre vendeur le plus proche.</p> <p>NOTE 2 : La conduite d'eau ne doit pas être en plastique (blanc). Les plombiers qualifiés doivent uniquement utiliser des tuyaux en cuivre #49595 ou #49599 ou un tuyau en polyéthylène réticulé (XLPE).</p>
---	--	---

6. TROUBLESHOOTING

6-1 Error Code Summary

▲ WARNING: When checking Resistance values, make sure to turn off the power, and wait for the voltage to discharge.

NOTE) Within 3 hours after the error : Press the Ice Plus button and Freezer button simultaneously

3 hours after the error : All errors, except for “rt E”, “HS E”, “IS E” (except for Icing room sensor), “SS E”, “Od E”, “IU E”, “Id E”, “gF E”, “It E” error, are displayed.

“IS E” which is displayed without input of user is the error of Icing Sensor.

Error Code ② Error Code ①

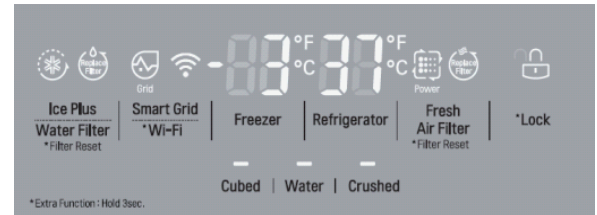

NO	Error Detection Category	Error Display		Error Generation Factors	Remark
		Freezer Temperature (Error code ②)	Refrigerator Temperature (Error code ①)		
1	Normal			None	Ration of display
2	Freezer Sensor Error	FS	E	Short or Disconnection of Freezer Sensor	Check each sensor at it's connector.
3	Refrigerator Sensor Error	rS	E	Short or Disconnection of Refrigerator Sensor	
4	Defrosting Sensor Error	dS	F	Short or Disconnection of Defrosting Sensor	
5	Icing Sensor Error	IS	E	Short or disconnection of the sensor about Ice maker (Icing sensor, Ice maker sensor)	
6	Humidity Sensor Error	HS	E	Short or Disconnection of Humidity	
7	Room Temp Sensor Error	rt	E	Short or Disconnectoin of Room temp.sensor	
8	Ice maker kit defect	It	E	Other Electric system error such as moter, gear, Hall IC, operation circuit within I/M kit	
9	Flow Meter(Sensor) Defect	gF	E	Error of flow meter or water input or low water pressure	Error of flow meter or water input or low water pressure or flow meter connection
10	Poor Defrosting	dH	F	During 2 consecutive cycles the defrosting sensor did reach over 46F (8C)	Temperature Fuse Disconnection, Heater disconnection, DRAIN Jam, Poor Relay for Heater
11	Abnormality of BLDC FAN Motor for Ice Making	IF	E	It is caused when feedback signal isn't over 65 seconds during BLDC FAN motor operating	Poor BLDC Motor connection, DRIVE IC, and TR
12	Abnormality of BLDC FAN Motor for Freezer	FF	E	It is caused when feedback signal isn't over 65 seconds during BLDC FAN motor operating	Poor BLDC Motor connection, DRIVE IC, and TR
13	Abnormality of BLDC FAN Motor for Mechanic Room	CF	E	It is caused when feedback signal isn't over 65 seconds during BLDC FAN motor operating	Poor BLDC Motor connection, DRIVE IC, and TR
14	Communication Error	CO	E	Communication Error between Micom of Main PCB and Display Micom	Poor Communication connection,Poor TR of Transmitter and Receiver Tx/Rx between display and main board.
15	Abnormal Pantry Sensor	SS	E	Humidity Sensor Short Or Open Circuit	Check sensor at it's connector
16	Abnormal Wi-Fi Modem	Od	E	Communication Error Between Display And Wi-Fi Modem	Poor Communication Connection (Short Or Open Circuit)Poor TR of Transmitter and Receiver Tx/Rx
17	Abnormal F Room IceMaker Tray Sensor	Id	E	Icemaker Tray Sensor Short Or Open Circuit	Check sensor at it's connector
18	Abnormal F Room IceMaker Kit	IU	E	Other Electrics System Error Such As Motor, Gear,Hall IC, Operation circuit Within I/M Kit	When the Ice Does not Drop even when the I/M Test S/W is pressed

7. PCB Picture

7-1. Main PCB

(P/N : EBR860937 **)

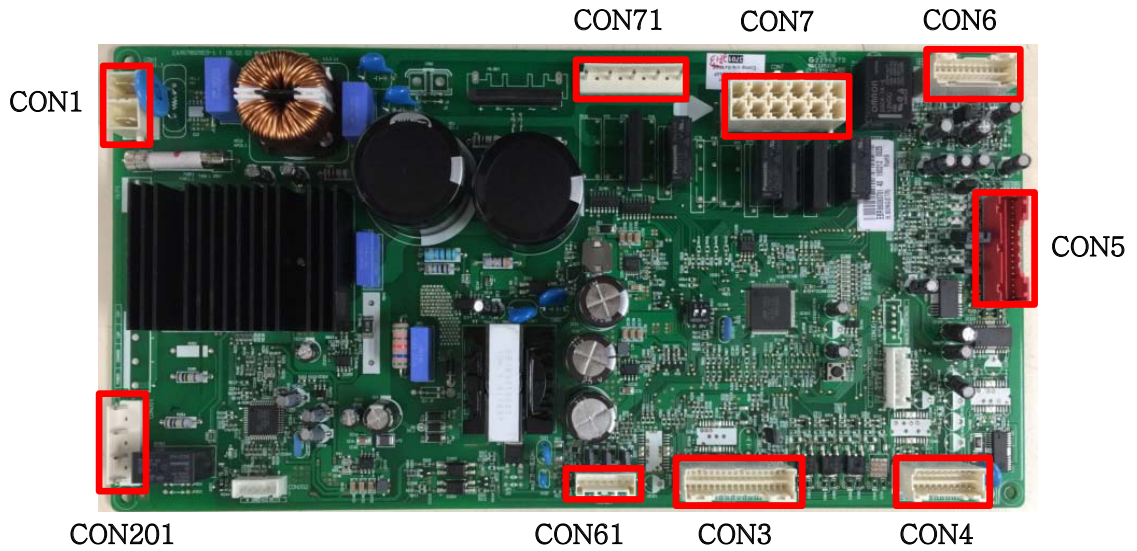

7-2. Display PCB

(P/N : EBR841464**)

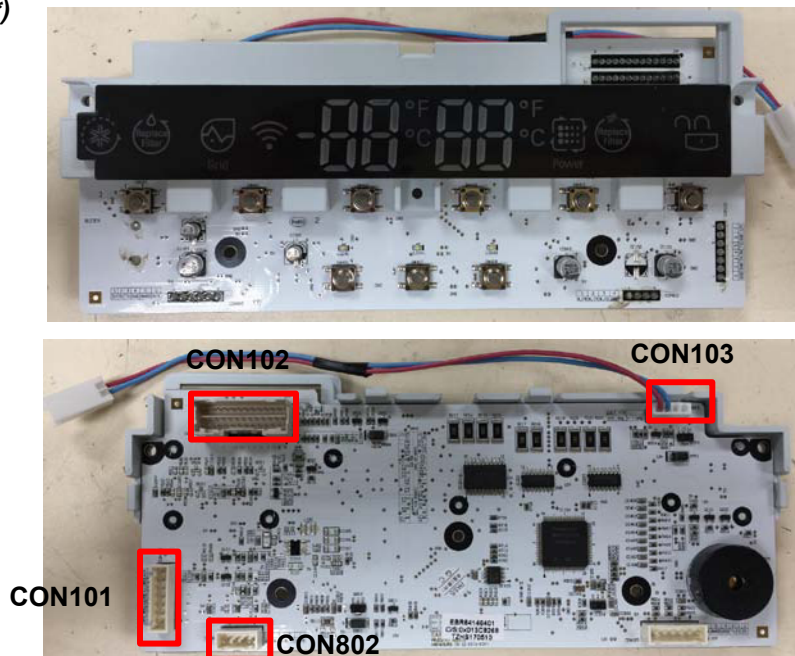

7. PCB Picture

7-3. Sub PCB

(P/N : EBR764684**)

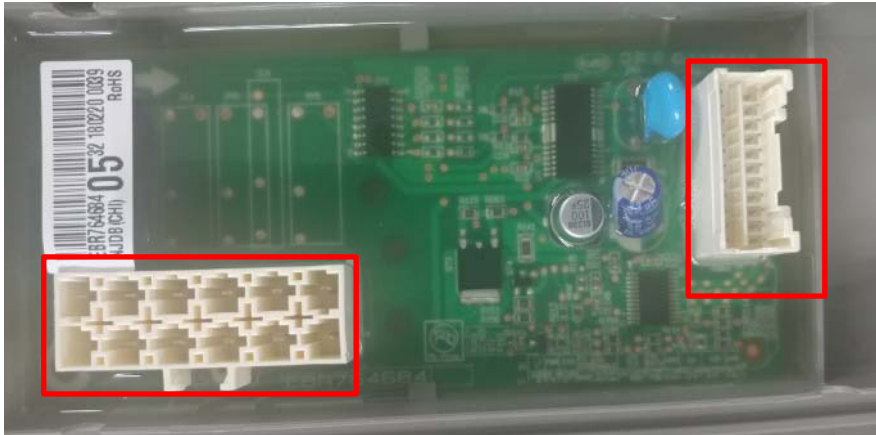

Con2

Con1

7-4. Sub PCB

(P/N : EBR640311**)

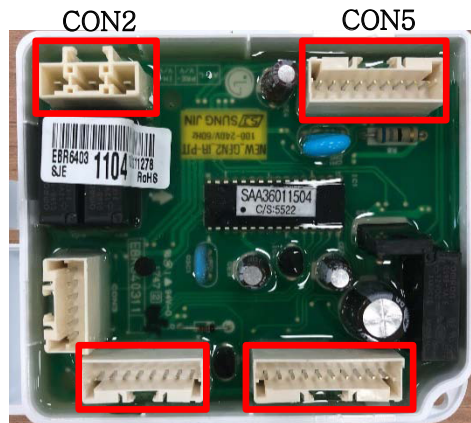

CON4

CON1

8. Trouble Shooting

8-1. Freezer Sensor Error (FS E)

Symptom	Check Point
1. FS E	1. Check for a loose connection 2. Check Sensor Resistance

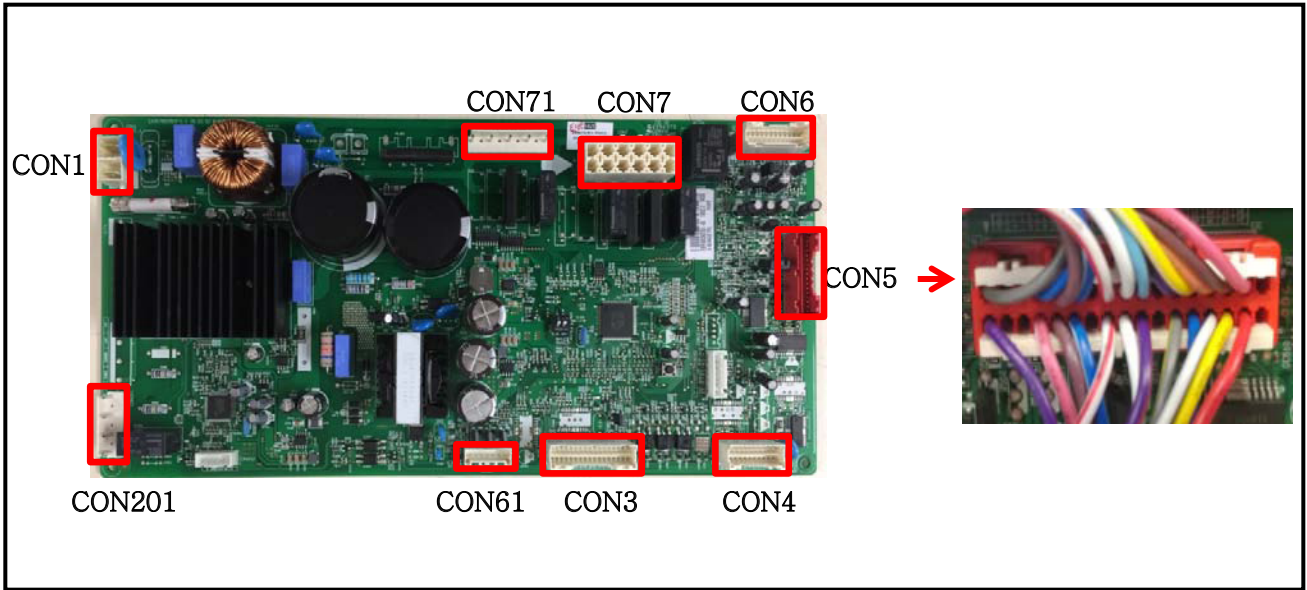

	Resistance [☒]	
	Short	0
CON5 12 th pin ~ 11 th pin	Open	OFF
	Other	Normal

CON5 12 th pin ~ 11 th pin	Resistance [☒]
-22°F / -30°C	40k
-13°F / -25°C	30k
-4°F / -20°C	23k
5°F / -15°C	17k
14°F / -10°C	13k
23°F / -5°C	10k
32°F / 0°C	8k

Freezer Sensor Error (FS E)

1
Is the Connector disconnected or loose between Main PCB and sensor?

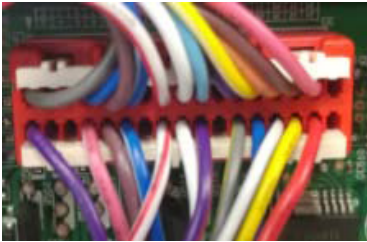

CON5

Yes

Reconnect or repair the connector

No

2
Check the Sensor resistance. Is resistance 0 Ω (Sensor short)?

Yes

Change the Sensor

No

3
Check the Sensor resistance. Is resistance OFF (Sensor open)?

Yes

Replace the refrigerator

No

4
Check the Sensor resistance. Is resistance normal?

Yes

5
Check the Temperature and resistance refer to the table. No problem?

CON5 12 th pin ~ 11 th pin	Resistance [Ω]
-22°F / -30°C	40k
-13°F / -25°C	30k
-4°F / -20°C	23k
5°F / -15°C	17k
14°F / -10°C	13k
23°F / -5°C	10k
32°F / 0°C	8k

Yes

6
Explain to customer

8-2. Refrigerator Sensor Error (rS E)

Symptom	Check Point
1. rS E	1. Check for a loose connection 2. Check Sensor Resistance

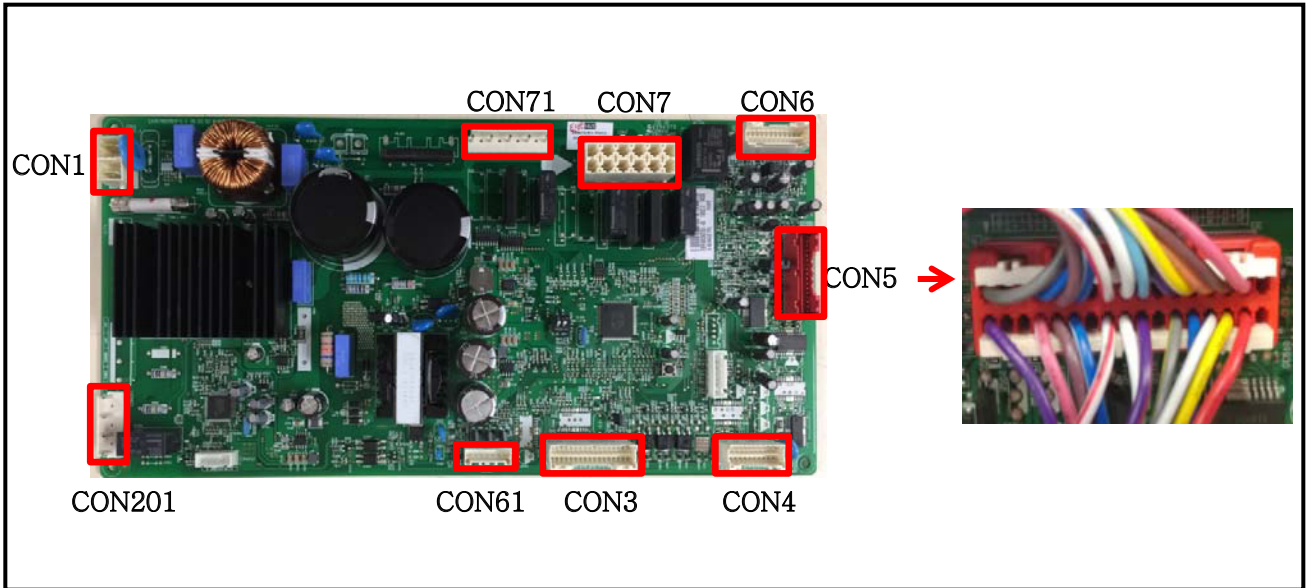

H/F FAN MOTOR MOTEUR H/F (M)	GY 1 PR 2 3-6	<table border="1"> <thead> <tr> <th colspan="2">Resistance [Ω]</th> </tr> </thead> <tbody> <tr> <td>Short</td> <td>0</td> </tr> <tr> <td>Open</td> <td>OFF</td> </tr> <tr> <td>Other</td> <td>Normal</td> </tr> </tbody> </table>	Resistance [Ω]		Short	0	Open	OFF	Other	Normal						
Resistance [Ω]																
Short	0															
Open	OFF															
Other	Normal															
#ROOM LED MODULE MODULE LED PIÈCE	BLRD 7 PKWH 8 BN 9 BN 10 BLWH 11 BLWH 12															
D-SENSOR CAPTEUR D	13-14	<table border="1"> <thead> <tr> <th colspan="2">Resistance [Ω]</th> </tr> </thead> <tbody> <tr> <td>CON5 18th pin ~ 17th pin</td> <td>Resistance [Ω]</td> </tr> <tr> <td>23°F / -5°C</td> <td>38k</td> </tr> <tr> <td>32°F / 0°C</td> <td>30k</td> </tr> <tr> <td>41°F / 5°C</td> <td>24k</td> </tr> <tr> <td>50°F / 10°C</td> <td>19.5k</td> </tr> <tr> <td>59°F / 15°C</td> <td>16k</td> </tr> </tbody> </table>	Resistance [Ω]		CON5 18 th pin ~ 17 th pin	Resistance [Ω]	23°F / -5°C	38k	32°F / 0°C	30k	41°F / 5°C	24k	50°F / 10°C	19.5k	59°F / 15°C	16k
Resistance [Ω]																
CON5 18 th pin ~ 17 th pin	Resistance [Ω]															
23°F / -5°C	38k															
32°F / 0°C	30k															
41°F / 5°C	24k															
50°F / 10°C	19.5k															
59°F / 15°C	16k															
F-SENSOR CAPTEUR F	WHRD 15 WHRD 16 WH 17 WH 18															
PANTRY-SENSOR DÉTECTEUR DE COMPTOIR	SB/BK 19 PR/RC 20															
R-SENSOR CAPTEUR R	21-22 PRWH 23															
BETA DUCT HEATER BETA DU CHAUFFAGE	GY/YL 24 YLWH 25															
F WATER PIPE HEATER RECHAUFFEUR CONDUITE D'EAU	BO 27 BNWH 29															
PANTRY STEPPING MOTOR MOTEUR PAS À PAS DE COMPTOIR (M)	PK 31															
REFRIGERATOR STEPPING MOTOR MOTEUR PAS À PAS RÉFRIGÉRATEUR (M)	BL 26 WH/BK 28 YL 30 RD 32 33-34 CON5															

Refrigerator Sensor Error (rS E)

1
Is the Connector disconnected or loose between Main PCB and sensor?

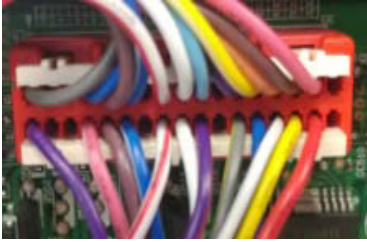

CON5

Yes

Reconnect or repair the connector

No

2
Check the Sensor resistance. Is resistance 0 \square (Sensor short)?

Yes

Change the Sensor

No

3
Check the Sensor resistance. Is resistance OFF (Sensor open)?

Yes

Replace the refrigerator

No

4
Check the Sensor resistance. Is resistance normal?

Yes

5
Check the Temperature and resistance refer to the table. No problem?

CON5 18 th pin ~ 17 th pin	Resistance [\square]
23°F / -5°C	38k
32°F / 0°C	30k
41°F / 5°C	24k
50°F / 10°C	19.5k
59°F / 15°C	16k

Yes

6
Explain to customer

8-3. Icing Sensor Error (IS E)

Symptom	Check Point
1. IS E	1. Check for a loose connection 2. Check Sensor Resistance

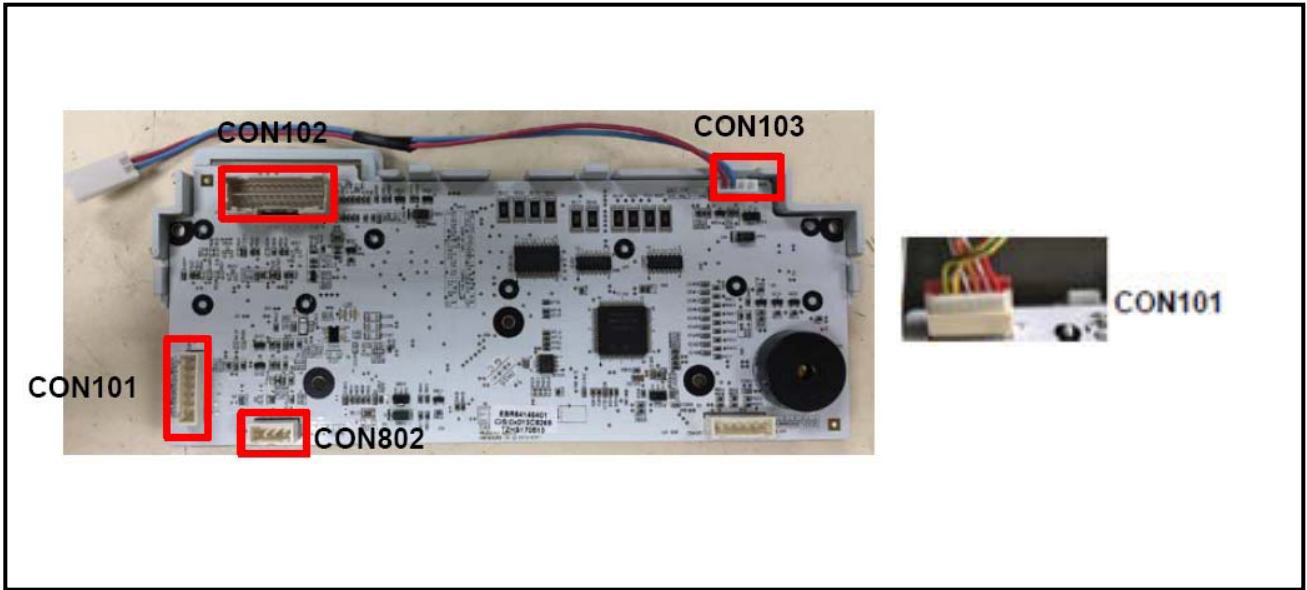

	Resistance [☒]	
	Short	0
	Open	OFF
	Other	Normal

CON101 1 st pin ~ 2 nd pin	Resistance [☒]
-22°F / -30°C	40k
-13°F / -25°C	30k
-4°F / -20°C	23k
-13°F / -25°C	17k
14°F / -10°C	13k
23°F / -5°C	10k
32°F / 0°C	8k

Icing Sensor Error (IS E)

1
Is the Connector disconnected or loose between Main PCB and sensor?

Yes

Reconnect or repair the connector

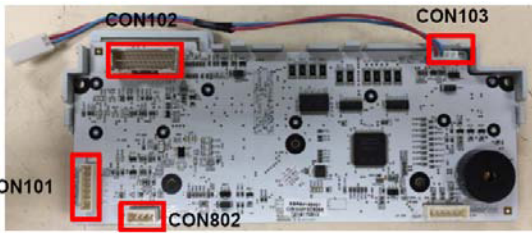

No

2
Check the Sensor resistance. Is resistance 0Ω (Sensor short)?

Yes

Change the Sensor

No

3
Check the Sensor resistance. Is resistance OFF (Sensor open)?

Yes

Replace the refrigerator

No

4
Check the Sensor resistance. Is resistance normal?

Yes

5
Check the Temperature and resistance refer to the table. No problem?

CON101 1 st pin ~ 2 nd pin	Resistance [Ω]
-22°F / -30°C	40k
-13°F / -25°C	30k
-4°F / -20°C	23k
-13°F / -25°C	17k
14°F / -10°C	13k
23°F / -5°C	10k
32°F / 0°C	8k

Yes

6
Explain to customer

8-4. Defrost Sensor Error (dS F)

Symptom	Check Point
1. dS F	1. Check for a loose connection 2. Check Sensor Resistance

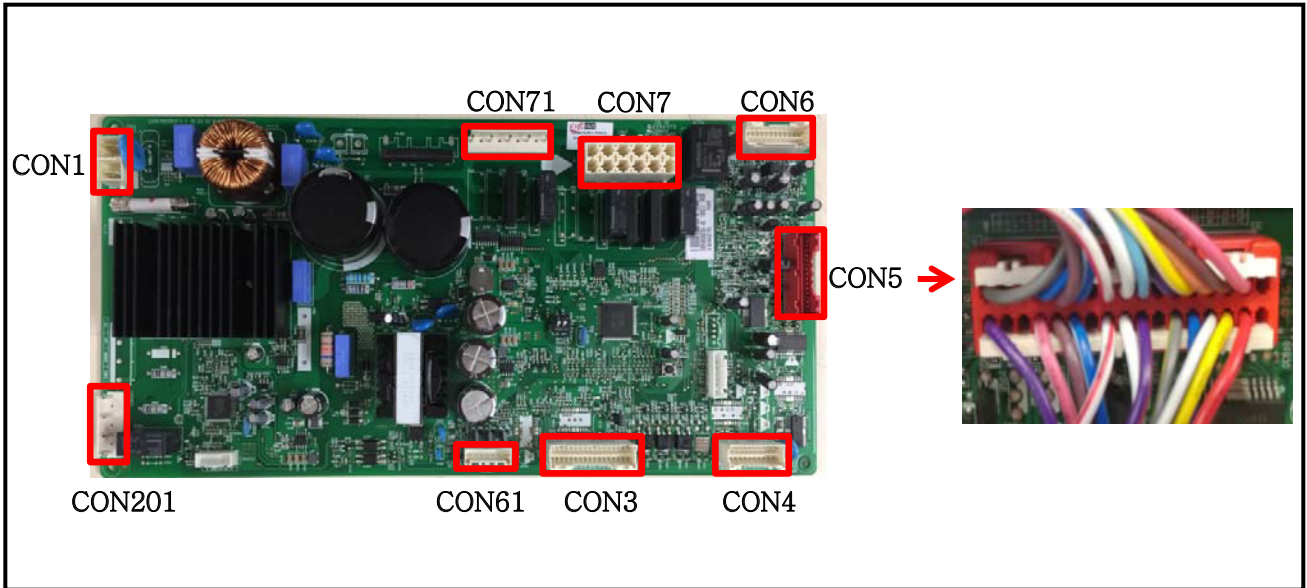

		Resistance [☒]	
CON5 10 th pin ~ 9 th pin	Short	0	
	Open	OFF	
	Other	Normal	

CON5 10 th pin ~ 9 th pin	Resistance [☒]
23°F / -5°C	38k
32°F / 0°C	30k
41°F / 5°C	24k
50°F / 10°C	19.5k
59°F / 15°C	16k

Defrost Sensor Error (dS F)

1
Is the Connector disconnected or loose between Main PCB, Defrost controller and Sensor?



CON5

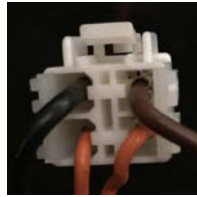

Yes

Reconnect or repair the connector

No

2
Check the Sensor resistance. Is resistance 0Ω (Sensor short) or resistance Infinity Ω (Sensor open) ?

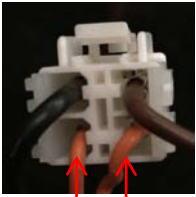

Yes

Change the Sensor

No

3
Check the Sensor resistance. Is resistance normal?

Yes

4
Check the Temperature and resistance refer to the table. No problem?

No

Change Main PCB

CON5 10 th pin ~ 9 th pin	Resistance [Ω]
23°F / -5°C	38k
32°F / 0°C	30k
41°F / 5°C	24k
50°F / 10°C	19.5k
59°F / 15°C	16k

Yes

5
Explain to customer

8-5. Ice Maker Motor Error (It E)

Symptom	Check Point
1. It E	<ol style="list-style-type: none"> 1. Check the Ice maker rotation 2. Check the motor voltage

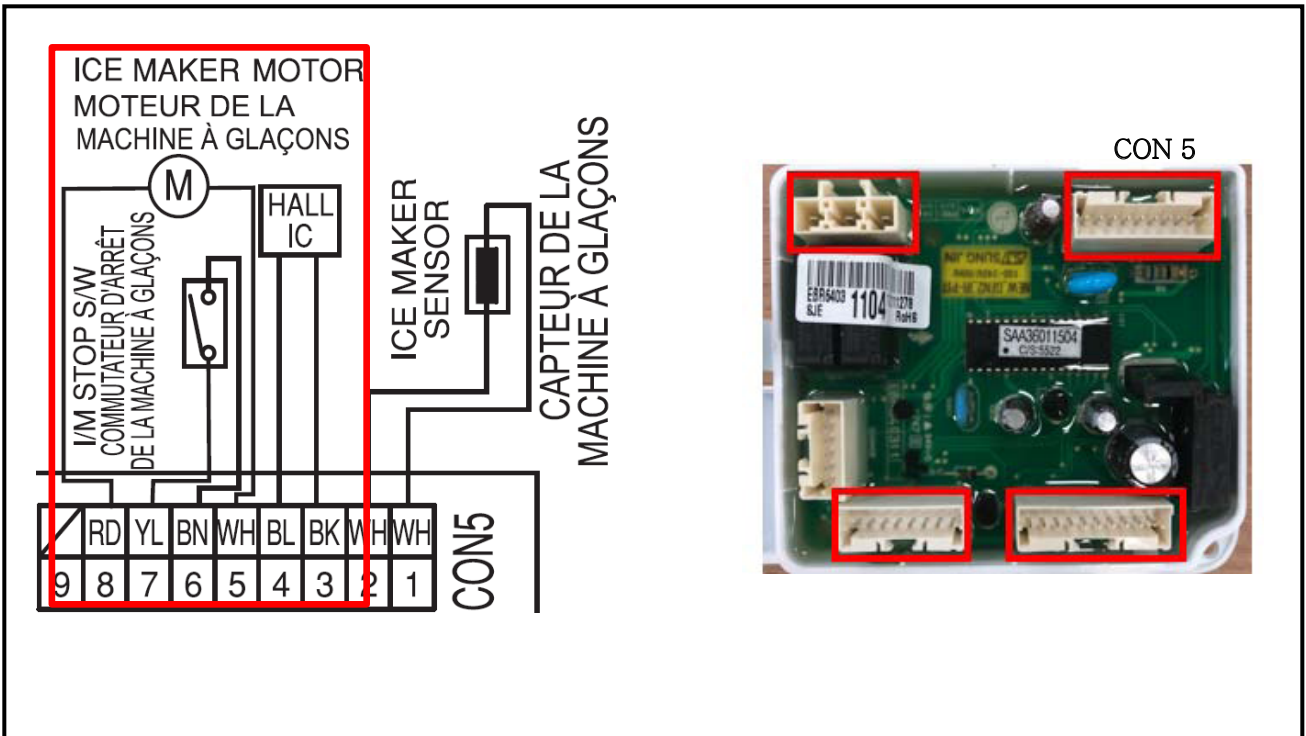
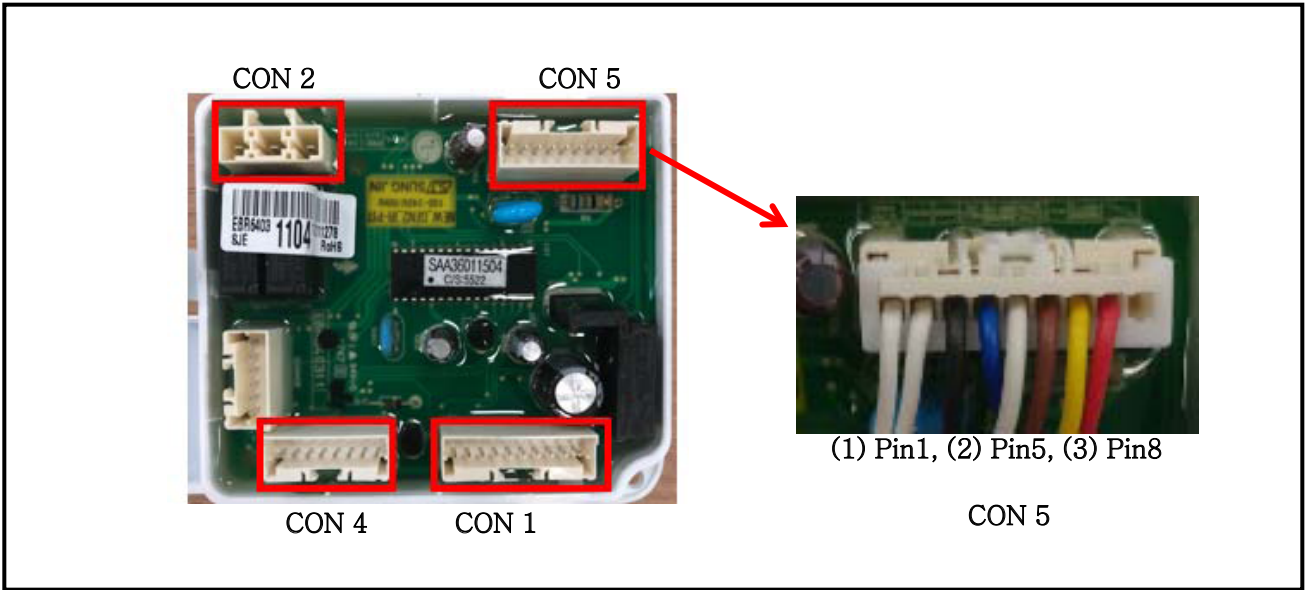

Ice Maker Motor Error (It E)

1
Input Ice Maker test mode(Push The ice maker test button),check The Ice Tray,Ice maker motor Rotate?



Yes
Explain to customer

No

2
Check the ice maker forward status
The voltage (1)~(2) point 11~12V?

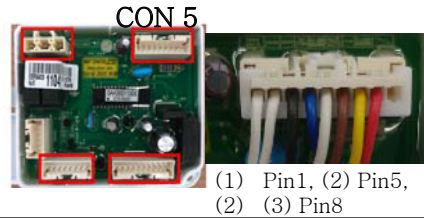

OR

3
Check the ice maker reverse status
The voltage (1)~(3) point 11~12V?

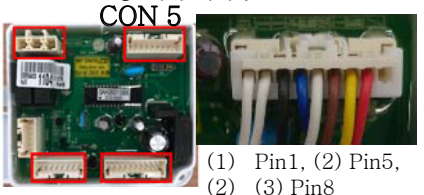

OR

Yes
Change the Ice maker kit

Yes
Change the Ice maker kit

4
Check the ice maker forward status
The voltage (1)~(2) point 0V?

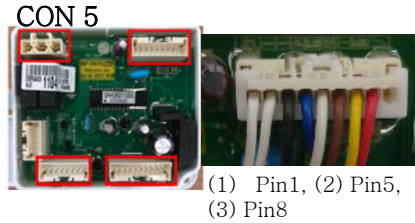

Yes
Change the Main PCB

OR

5
Check the ice maker reverse status
The voltage (1)~(3) point 0V?

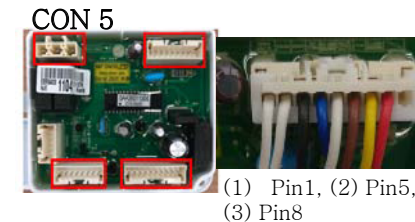

Yes
Change the Main PCB

No

8-6. Defrost Heater Error (dH F)

Symptom	Check Point
1. dH F	<ol style="list-style-type: none"> 1. Check the door gasket 2. Check the Defrost control part 3. Check the PCB output voltage

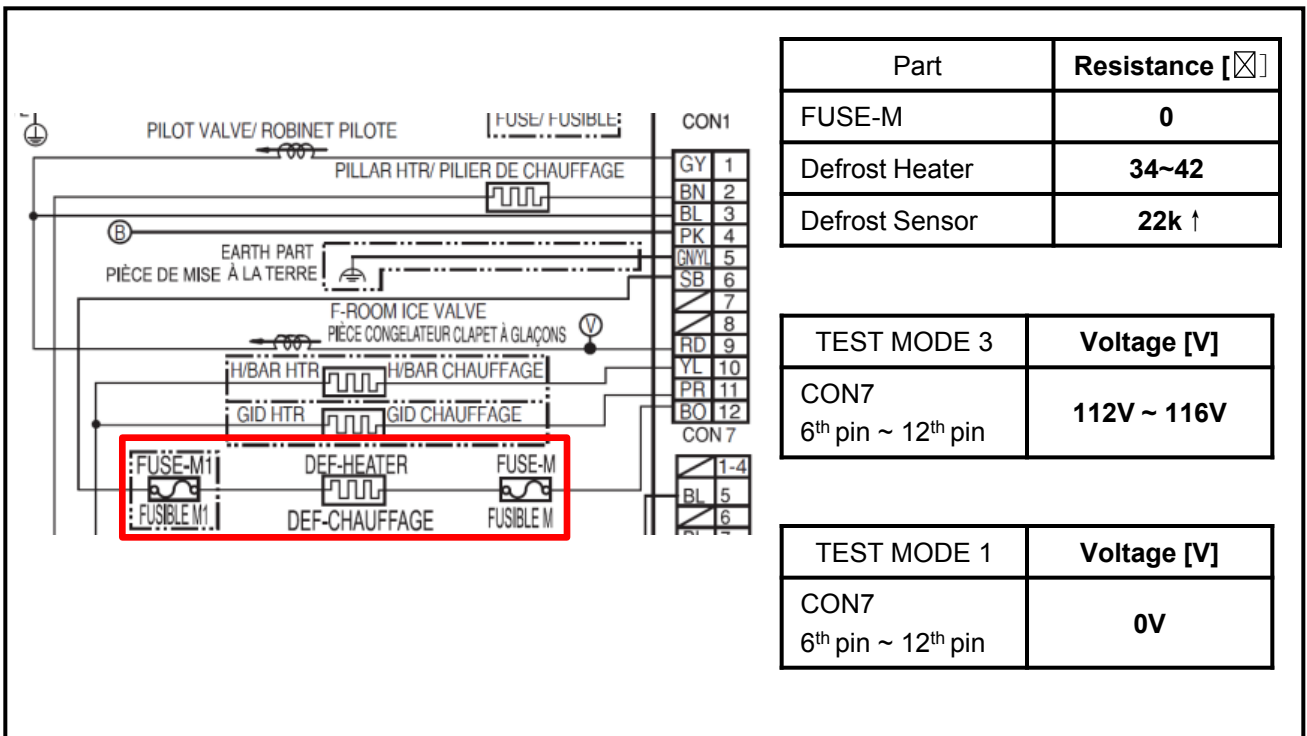
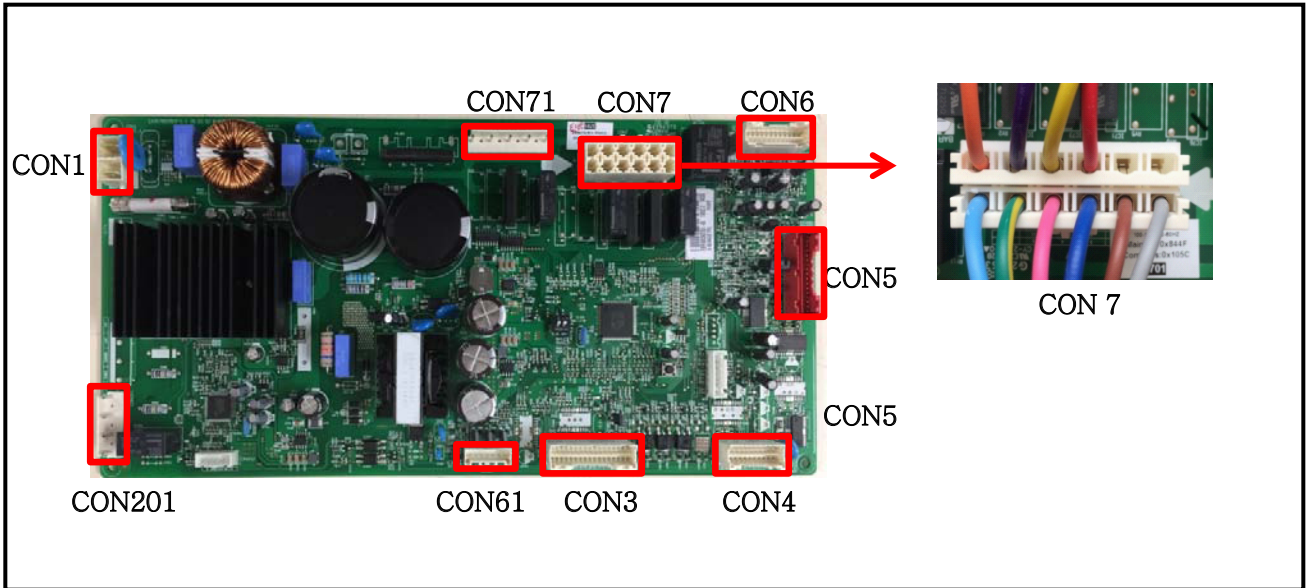

Defrost Heater Error (dH F)

1
Check the Door gasket .
Is door gasket damaged?

Yes → Replace the Door gasket

No

2
Check the Defrost control part.
(1) Is Fuse-M resistance 34~42Ω?

No → Change Defrost Heater

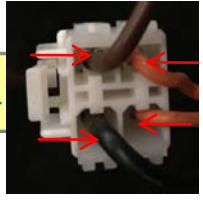

Fuse -M
Deforest Heater

Deforest SNR

Yes

3
Check the Defrost control part.
Is Defrost Sensor resistance 22kΩ for OFF?

OFF → Replace product

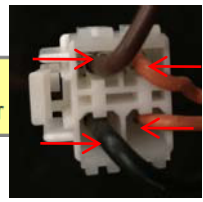

Fuse -M
Deforest Heater

Deforest SNR

22kΩ ↑

**4 Input Test 3 Mode
(Push the button 3 times)**
Check the Heater Voltage.
Is voltage 112V ~ 116V?

NO → Replace Main PCB

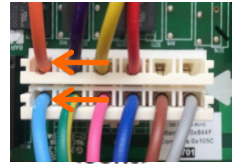

TEST MODE 3	Voltage [V]
CON7 6 th pin ~ 12 th pin	112V ~ 116V

Yes

**5 Input Test 1 Mode
(Push the button 1 times)**
Check the Heater Voltage.
Is voltage 0V?

No → Replace Main PCB

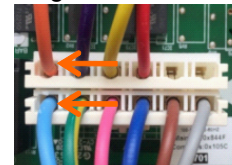

TEST MODE 1	Voltage [V]
CON7 6 th pin ~ 12 th pin	0V

Yes

6
Explain to customer

8-7. Freezer Fan Error (FF E)

Symptom	Check Point
1. FF E	<ol style="list-style-type: none"> 1. Check the air flow 2. Check the Fan Motor 3. Check the PCB Fan motor voltage

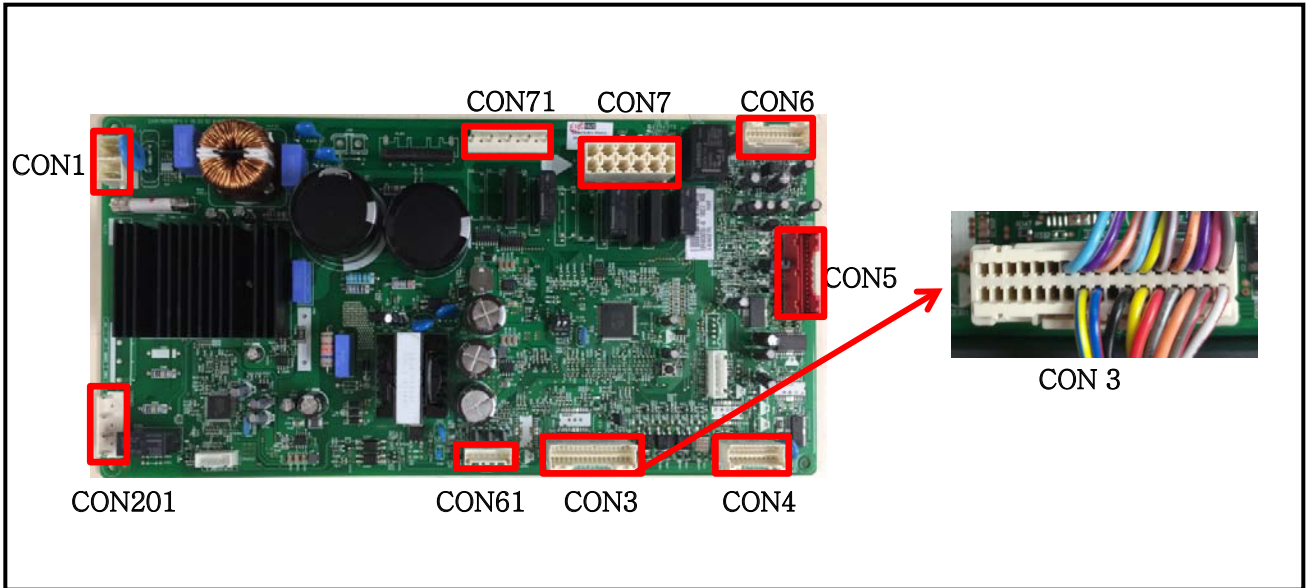

TEST MODE 1	Voltage [V]
CON7 8 th pin ~ 5 th pin	12V
CON7 6 th pin ~ 5 th pin	0V<Voltage<5V
CON7 7 th pin ~ 5 th pin	0V<Voltage<5V

Freezer Fan Error (FF E)

- 1 Reset the unit and Input Test1 Mode. (Push the button 1 time)**



- 2** Open the freezer door and Check the air flow. Windy?



No Go to 3

Yes

Go to 4

- 3** Check the Fan motor. Rotate fan using hand. It feel sticky?

Fan Motor



Yes Change the Fan motor

- 4** Check the Fan Motor voltage Is Fan Motor voltage 12V?



CON3

No Replace Main PCB

TEST MODE 1	Voltage [V]
CON7 8 th pin ~ 5 th pin	12V

Yes

- 5** Check the Fan Motor voltage Is Fan control signal voltage between 0V and 5V?



CON3

No Replace Main PCB

TEST MODE 1	Voltage [V]
CON7 6 th pin ~ 5 th pin	0V<Voltage<5V

No

- 6** Check the Fan Motor voltage Is Fan feed back voltage between 0V and 5V?



CON3

No Replace Motor

TEST MODE 1	Voltage [V]
CON7 7 th pin ~ 5 th pin	0V<Voltage<5V

No

- 7** Explain to customer

8-8. Icing Fan Error (IF E)

Symptom	Check Point
1. IF E	<ol style="list-style-type: none"> 1. Check the air flow 2. Check the Connector 3. Check the PCB Fan motor voltage

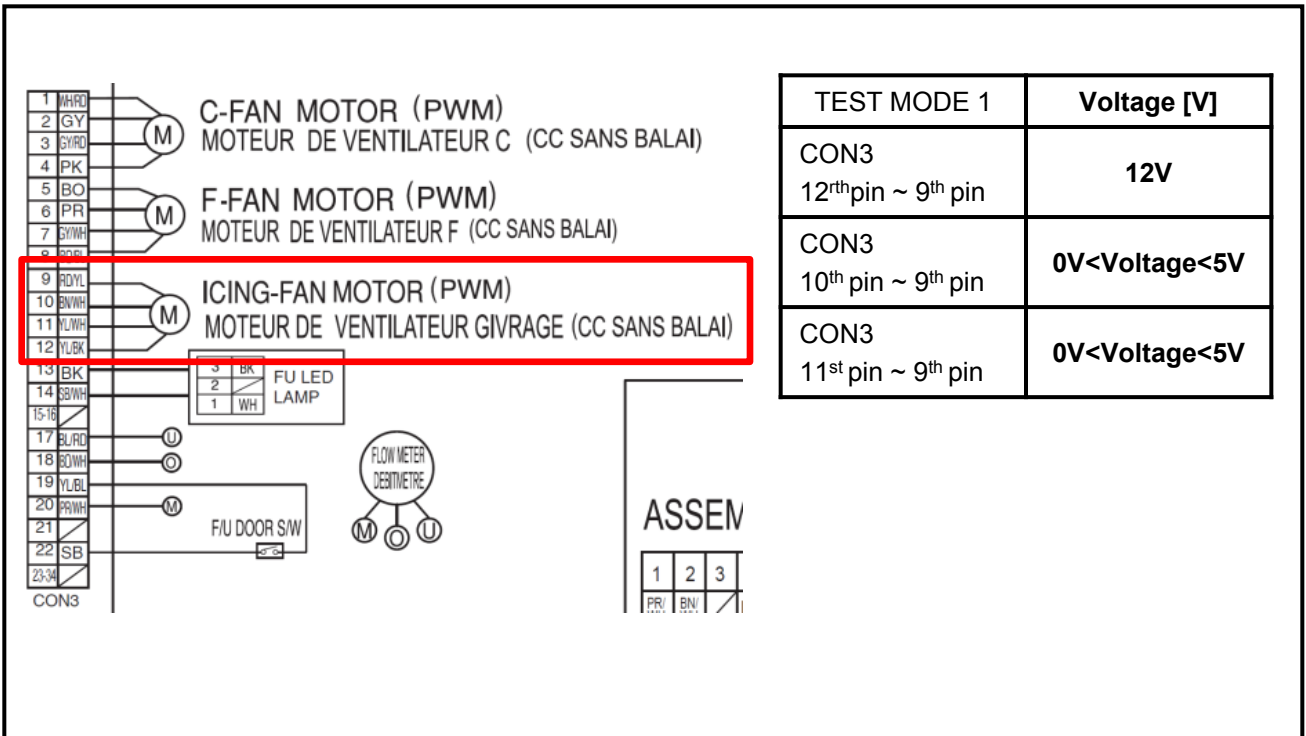
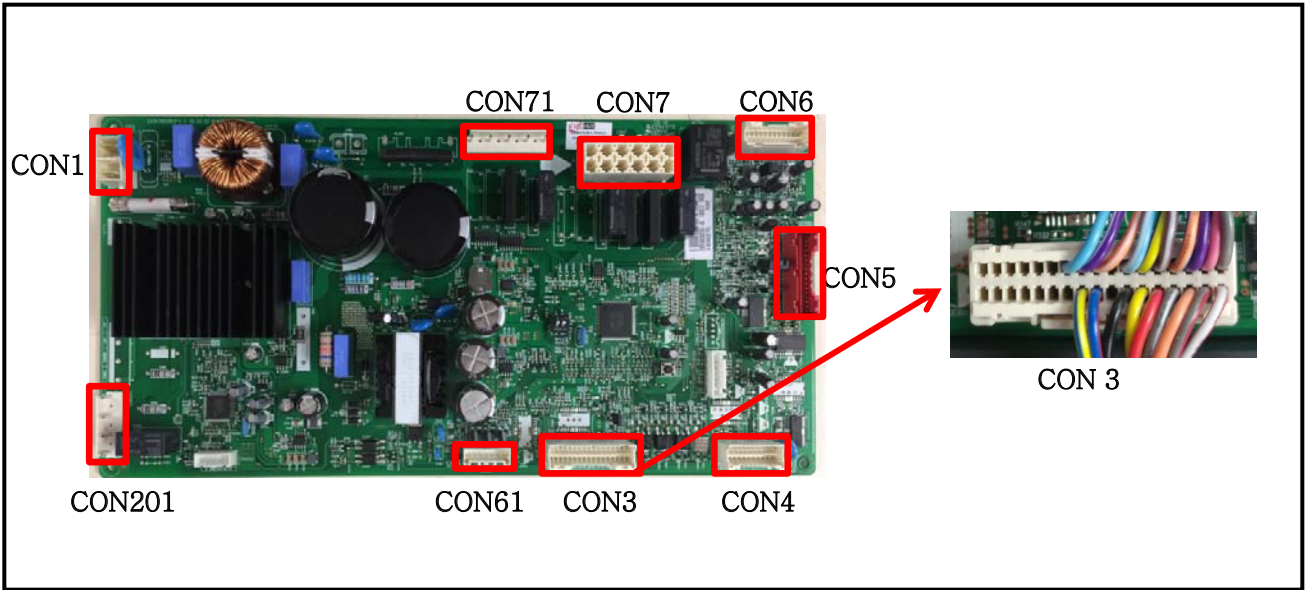

Freezer Fan Error (IF E)

- 1 Reset the unit and Input Test1 Mode. (Push the button 1 time)**



- 2** Open the freezer door and Check the air flow. Windy?



Yes

Go to 4

- 3** Check the Fan motor. Rotate fan using hand. It feel sticky?

Fan Motor

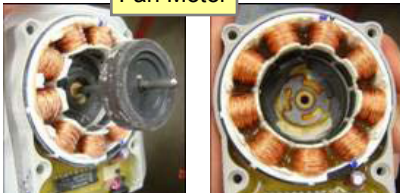

Yes Change the Fan motor

- 4** Check the Fan Motor voltage Is Fan Motor voltage 12V?



CON3

TEST MODE 1	Voltage [V]
CON3 12 th pin ~ 9 th pin	12V

No

Replace Main PCB

Yes

- 5** Check the Fan Motor voltage Is Fan control signal voltage between 0V and 5V?



CON3

TEST MODE 1	Voltage [V]
CON3 10 th pin ~ 9 th pin	0V<Voltage<5V

No

Replace Main PCB

No

- Check the Fan Motor voltage Is Fan feed back voltage between 0V and 5V?



CON3

TEST MODE 1	Voltage [V]
CON3 11 st pin ~ 9 th pin	0V<Voltage<5V

No

Replace Motor

No

- 7** Explain to customer

8-9. Condenser Fan Error (CF E)

Symptom	Check Point
1. CF E	<ol style="list-style-type: none"> 1. Check the air flow 2. Check the Connector 3. Check the PCB Fan motor voltage

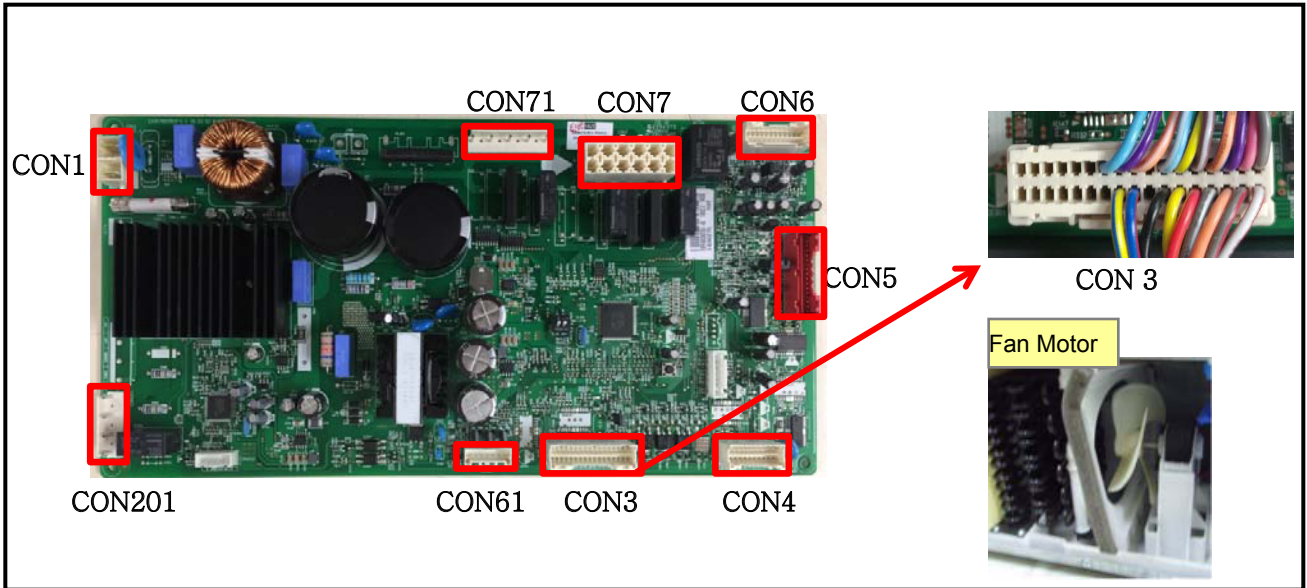

C-FAN MOTOR (PWM)
MOTEUR DE VENTILATEUR C (CC SANS BALAI)

F-FAN MOTOR (PWM)
MOTEUR DE VENTILATEUR F (CC SANS BALAI)

ICING-FAN MOTOR (PWM)
MOTEUR DE VENTILATEUR GIVRAGE (CC SANS BALAI)

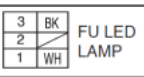

TEST MODE 1	Voltage [V]
CON3 4 th pin ~ 1 st pin	12V
CON3 2 nd pin ~ 1 st pin	0V<Voltage<5V
CON3 3 rd pin ~ 1 st pin	0V<Voltage<5V

Condenser Fan Error (CF E)

- 1 Reset the unit and Input Test1 Mode. (Push the button 1 time)**



- 2 Check the fan rotating. Does fan rotate?**



Yes

Go to 4

- 3 Check the Fan motor. Rotate fan using hand. It feel sticky?**

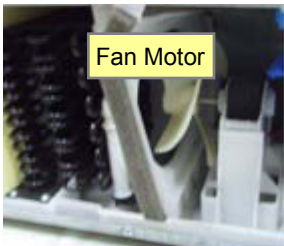

Yes

Change the Fan motor

- 4 Check the Fan Motor voltage Is Fan Motor voltage 12V?**



CON 3

TEST MODE 1	Voltage [V]
CON3 4 th pin ~ 1 st pin	12V

No

Replace Main PCB

Yes

- 5 Check the Fan Motor voltage Is Fan control signal voltage between 0V and 5V?**



CON 3

TEST MODE 1	Voltage [V]
CON3 2 nd pin ~ 1 st pin	0V<Voltage<5V

No

Replace Main PCB

No

- Check the Fan Motor voltage Is Fan feed back voltage between 0V and 5V?**

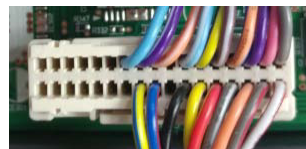

CON 3

TEST MODE 1	Voltage [V]
CON3 3 rd pin ~ 1 st pin	0V<Voltage<5V

No

Replace Motor

No

- 7 Explain to customer**

8-10. Communication Error (CO E)

Symptom	Check Point
1. CO E	<ol style="list-style-type: none"> 1. Check the loose connection 2. Check the Hinge connection

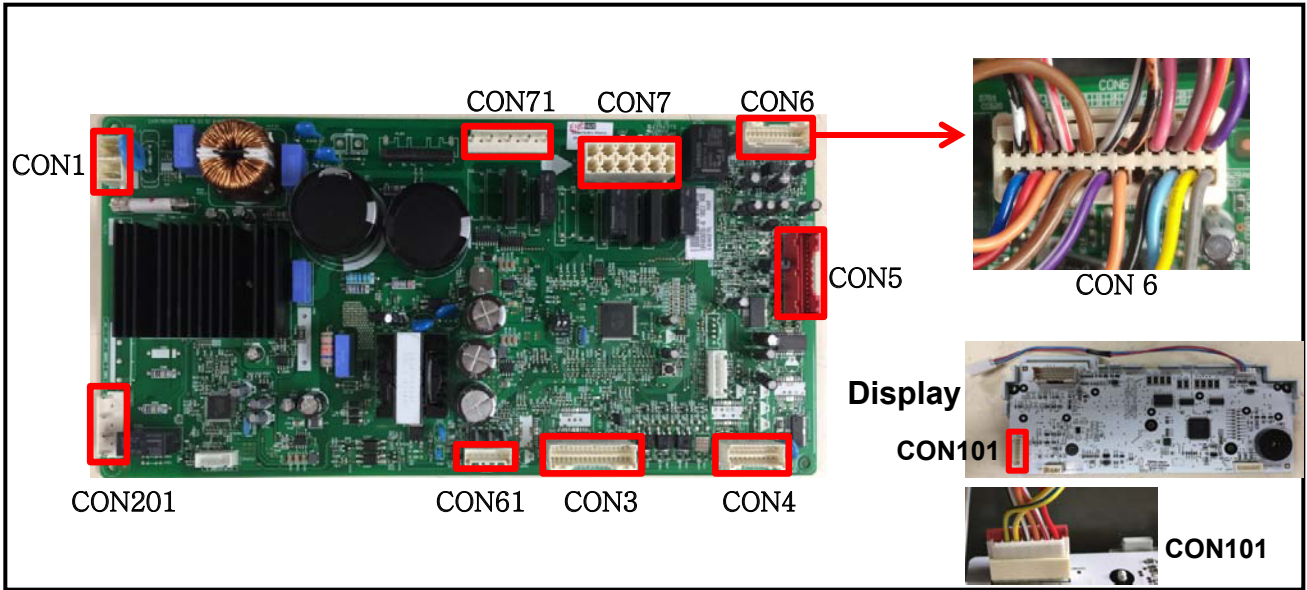

CON101		CON101	
6	RD	RD	7
9	WH/RD	WH/RD	6
8	BO	BO	5
10	WH/BK	WH/BK	4
5	YL/WH	YL/WH	3
4	BL	PR/WH	2
7	GY/WH	BL/RD	1
3	BK		
11	BN		
12	BN		
13	BL		
14	PR/WH		
15	BO/BL		
16	BO/BL		
17-18			
19	PK		
23	RD/YL		
24	YL		
20	YL/BK		
22	SB		
21	BN/WH		
25	PR		
26	GY		
CON6			

	Voltage [V]
CON101 7 th pin ~ 6 th pin	12V
CON101 5 th pin ~ 6 th pin	Not 0V, 5V
CON101 4 th pin ~ 6 th pin	Not 0V, 5V
CON5 3 th pin ~ 6 th pin	5V

Communication Error (CO E)

1
Check the loose connection

No

2
Check the voltage.
Are CON101 7th pin ~ 6th pin
voltage 12V?
And CON101 3rd pin ~ 6th pin ?

No
Check the
Hinge (loose
connection)
Change the
Main PCB

Housing	Voltage [V]
CON101 7 th pin ~ 6 th pin	12V
CON101 3 rd pin ~ 6 th pin	5V

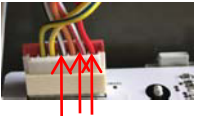

Yes

3
Check the voltage.
Is CON101 5th pin ~ 6th pin
voltage 0V or 5V?

Yes
Change the
Display PCB

Housing	Voltage [V]
CON101 5 th pin ~ 6 th pin	Not 0V, 5V

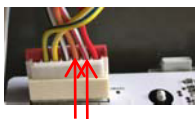

No

4
Check the voltage.
Is CON101 4th pin ~ 6th pin
voltage 0V or 5V?

Yes
Change the
Main PCB

Housing	Voltage [V]
CON101 4 th pin ~ 6 th pin	Not 0V, 5V

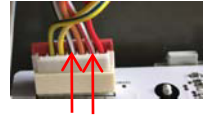

No

5
Check the voltage.
Is CON6 8th pin ~ 9th pin
voltage 0V or 5V?

Yes
Change the
Display PCB



Housing	Voltage [V]
CON6 10 th pin ~ 9 th pin	Not 0V, 5V

No

6
Check the voltage.
Is CON6 10th pin ~ 9th pin
voltage 0V or 5V?

Yes
Change the
Main PCB

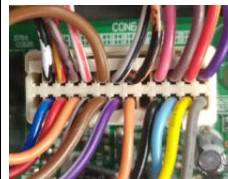

Housing	Voltage [V]
CON6 10 th pin ~ 9 th pin	Not 0V, 5V

No

7
Explain to customer

8-11. Cube mode doesn't work

Symptom	Check Point
1. Cube mode doesn't work	1. Check the loose connection 2. Check the resistance

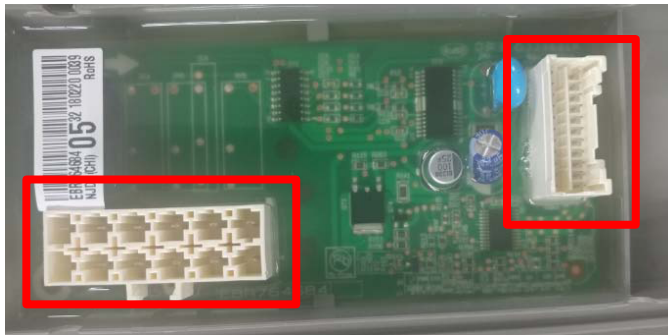

CON2

CON1

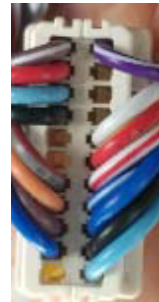

Ice Maker



Geared Motor



Dispenser Motor

8-11. Cube mode doesn't work

l)

SANS BALAI)

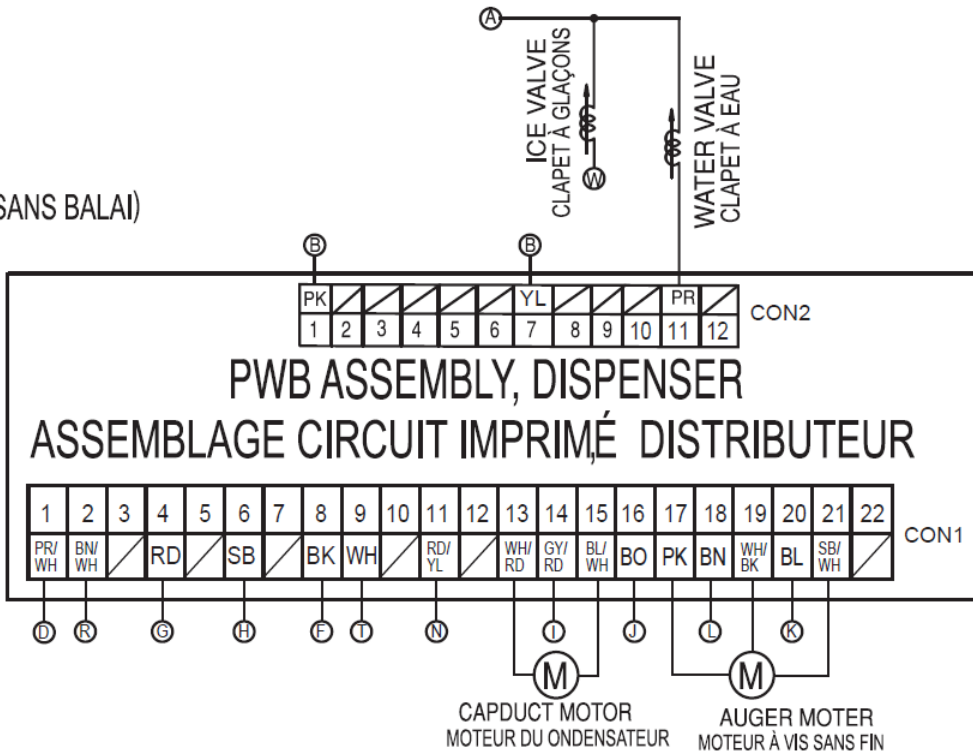

	Resistance [Ω]
CON1 17 th pin, 19 th pin 17 th pin, 21 th pin 19 th pin, 21 th pin	2.55±7%

	Voltage [V]
CON1 2 nd pin, 6 th pin	24V±10%

Pushing The LEVER S/W	Voltage [V]
CON1 20 th pin, 6 th pin 14 th pin, 6 th pin	5V±10%

Cube mode doesn't work

1 Check the Auger Motor
(Working Sound
Visual inspection)

No Check the Ice Bucket

Yes

2 Check the SUB PCB Resistance Value



No Change the Dispenser Assembly, Ice (Loc. 600C)

CON1 17 th pin, 19 th pin 17 th pin, 21 th pin 19 th pin, 21 th pin	Resistance [Ω]
U, V, W	2.55±7%

Yes

3 Check the SUB PCB voltage Value

No Change the Item ⑤ (Main PCB Voltage Value)



CON1 2nd pin, 6 th pin	Voltage [V]
24V	24V±10%

While pushing the lever S/W is voltage correct?

CON1 2nd pin, 6 th pin	Voltage [V]
PWM	5V±10%

No Change the Case Assembly, PCB (Loc. 500C)

CON1 14 th pin, 6 th pin	Voltage [V]
24V Enable	5V±10%

Yes

4 Check the Display PCB Voltage Value

No Change the Cover Assembly, Display (Loc. 279A)

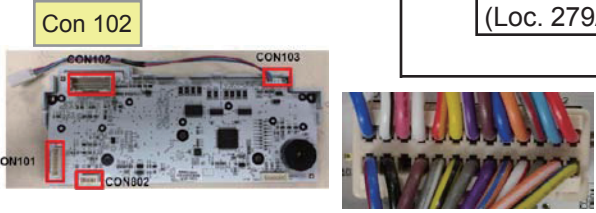

CON102 10 th pin, 23 th pin	Voltage [V]
PWM	5V±10%

CON102 6 th pin, 23 th pin	Voltage [V]
24V Enable	5V±10%

Yes

5 Check the Main PCB Voltage Value

No Change the PCB Assembly, Main (Loc. 500A)

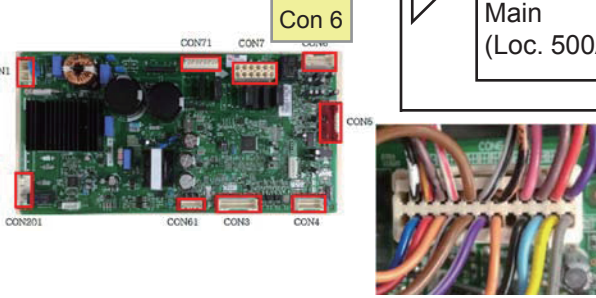

CON6 4 th pin, 3 th pin	Voltage [V]
24V	24V±10%

Yes

6 Explain to customer

※ Sub PCB Voltage NG or, When Main PCB Voltage is OK, Estimated Harness open circuit.

8-12. Crush mode doesn't work

Symptom	Check Point
1. Crush mode doesn't work	1. Check the loose connection 2. Check the resistance

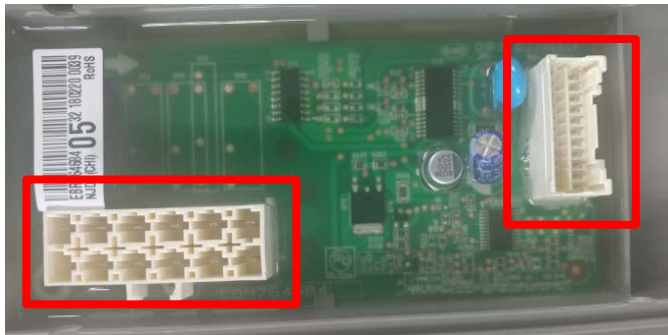

CON2

CON1

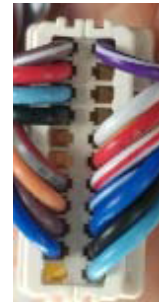

Ice Maker



Geared Motor



Dispenser Motor

8-12. Crush mode doesn't work

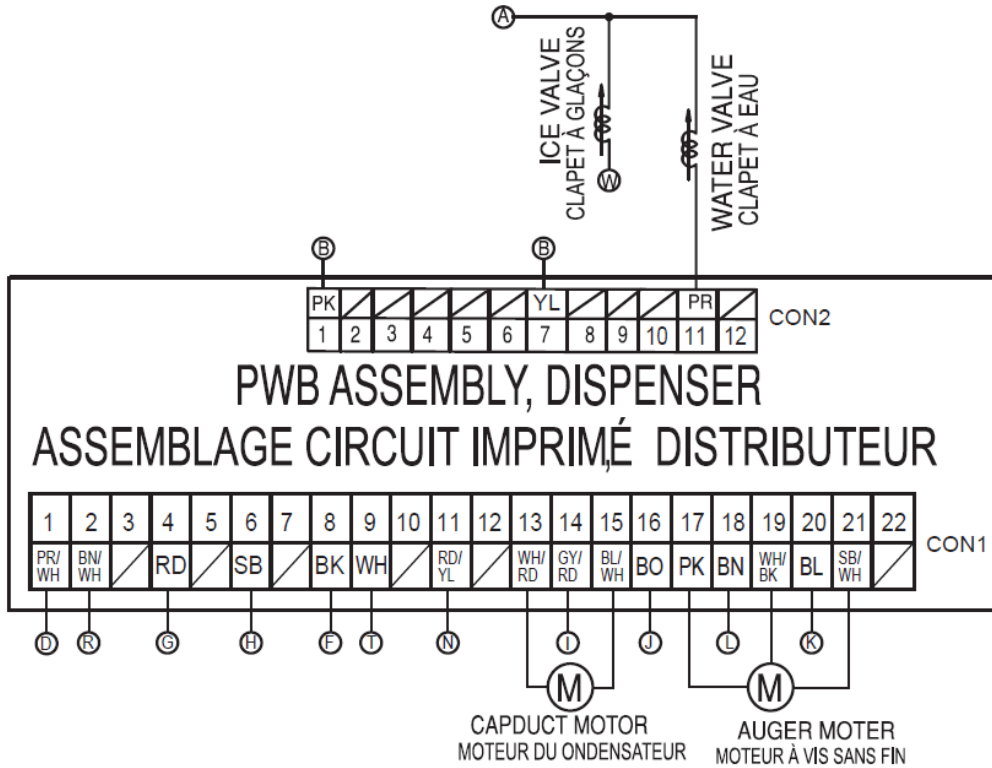

	Resistance [Ω]
CON1 17 th pin, 19 th pin 17 th pin, 21 th pin 19 th pin, 21 th pin	2.55±7%

	Voltage [V]
CON1 2 nd pin, 6 th pin	24V±10%

Pushing The LEVER S/W	Voltage [V]
CON1 20 th pin, 6 th pin 14 th pin, 6 th pin	5V±10%

Crush mode doesn't work

1 Check the Auger Motor
(Working Sound
Visual inspection)

No
Check the Ice Bucket

Yes

2 Check the SUB PCB Resistance Value



No
Change the Dispenser Assembly, Ice (Loc. 600C)

CON1 17 th pin, 19 th pin 17 th pin, 21 th pin 19 th pin, 21 th pin	Resistance [Ω]
U, V, W	2.55±7%

Yes

3 Check the SUB PCB voltage Value

No
Change the Item ⑤ (Main PCB Voltage Value)

※ Sub PCB Voltage NG or, When Main PCB Voltage is OK, Estimated Harness open circuit.

No
Change the Case Assembly, PCB (Loc. 500C)



CON1 2nd pin, 6 th pin	Voltage [V]
24V	24V±10%

While pushing the lever S/W is voltage correct?

CON1 2nd pin, 6 th pin	Voltage [V]
PWM	5V±10%

CON1 14 th pin, 6 th pin	Voltage [V]
24V Enable	5V±10%

Yes

4 Check the Display PCB Voltage Value

No
Change the Cover Assembly, Display (Loc. 279A)

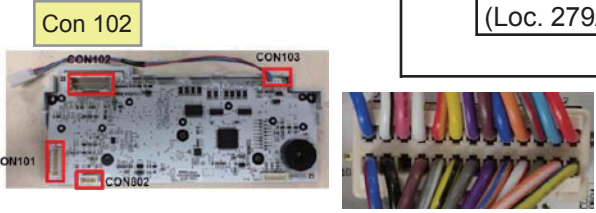

CON102 10 th pin, 23 th pin	Voltage [V]
PWM	5V±10%

CON102 6 th pin, 23 th pin	Voltage [V]
24V Enable	5V±10%

Yes

5 Check the Main PCB Voltage Value

No
Change the PCB Assembly, Main (Loc. 500A)

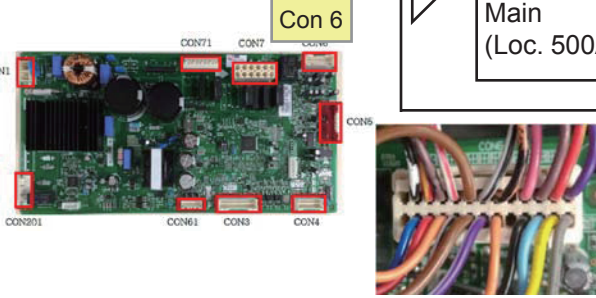

CON6 4 th pin, 3 th pin	Voltage [V]
24V	24V±10%

Yes

6 Explain to customer

8-13. Water mode doesn't work

Symptom	Check Point
1. Water mode doesn't work	1. Check the loose connection 2. Check the resistance valve

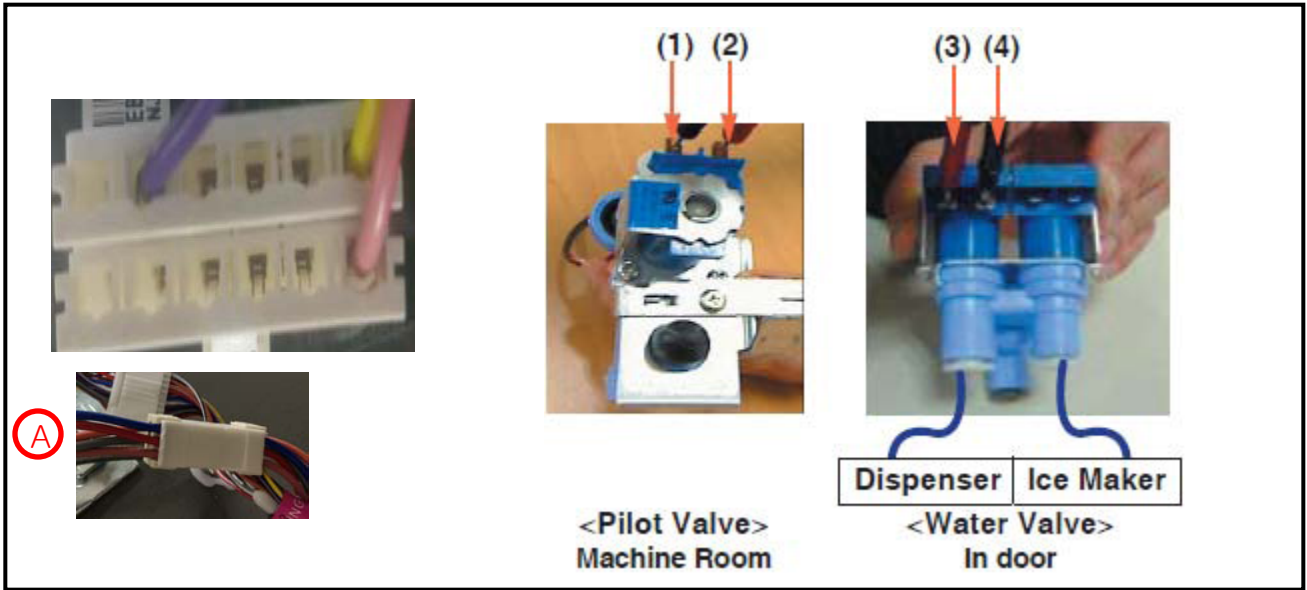

1) SANS BALAI)

LEVER S/W	Voltage [V]	
CON2 11 th pin ~ Neutral	Pushing	112~115V
	Not Pushing	0~2V

	Resistance [\square]
Pilot Valve	360~420
Water valve	360~420

PWB ASSEMBLY, DISPENSER
ASSEMBLAGE CIRCUIT IMPRIMÉ DISTRIBUTEUR

CON1

CON2

ICE VALVE
CLAPET À GLAÇONS

WATER VALVE
CLAPET À EAU

CAPDUCT MOTOR
MOTEUR DU ONDENSATEUR

AUGER MOTER
MOTEUR À VIS SANS FIN

Water mode doesn't work

1
Check the loose connection

2
Check the voltage.
(while pushing the lever S/W)
Is voltage correct?

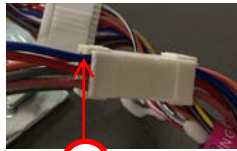

LEVER S/W CON2 11 th pin ~ Neutral	Voltage [V]	
	Pushing	112~115V
Not Pushing	0~2V	

No
Change the PCB

3
Check the resistance value.
Is Pilot Valve resistance
360~420 Ω?

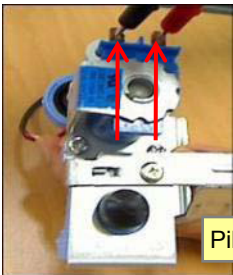

Pilot Valve

	Resistance [Ω]
Pilot Valve	360~420

No
Replace Water Valve

4
Check the resistance value.
Is Water Valve resistance
360~420 Ω?

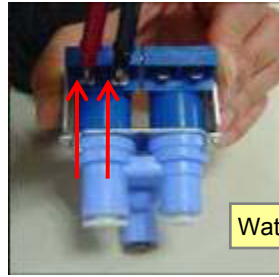

Water Valve

	Resistance [Ω]
Water valve	360~420

No
Replace Water Valve

5
Explain to customer

Yes

Yes

Yes

8-14. Refrigerator room lamp doesn't work

Symptom	Check Point
1. Refrigerator room lamp doesn't work	<ol style="list-style-type: none"> 1. Check the Refrigerator door switch sticky 2. Check the door S/W resistance 3. Check the LED Lamp

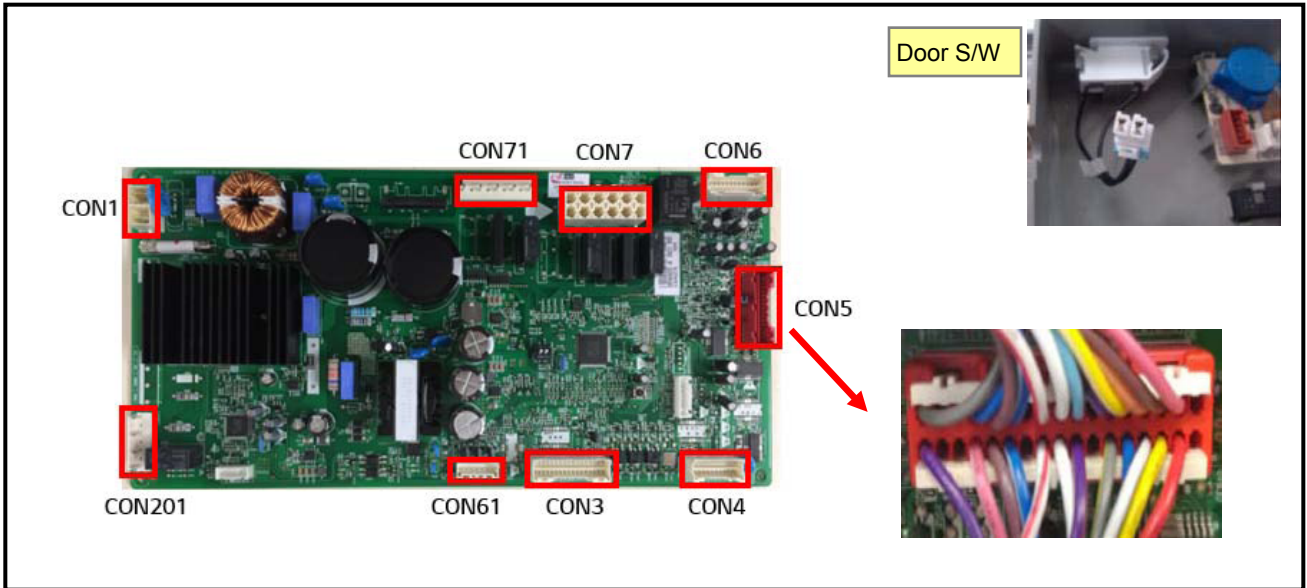

		S/W Resistance [\square]	
Door	Open	Infinity	
	Close	0	

		Voltage [V]
CON5	8 th pin ~ 7 th Pin	12V

LED Lamp		Voltage [V]	
White~ Yellow	Closed	0~2V	
	Open	12V	

Refrigerator room lamp doesn't work

1 Check the Refrigerator door switch. Does it feel sticky?



Yes → Change the Door S/W

No →

2 Check the door S/W resistance. Is it correct compared with table?

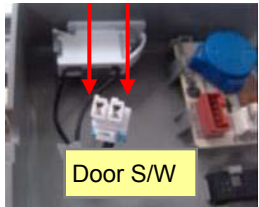

No → Change the Door S/W

		S/W Resistance [Ω]	
Door	Open	Infinity	
	Close	0	

Yes →

3 Check the PCB Voltage. Is CON7 33th pin ~ 34th pin voltage 12V?

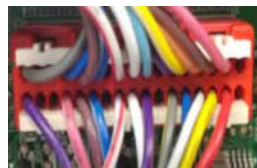

No → Change the PCB

		Voltage [V]
CON5	8 th pin ~ 7 th Pin	12V

Yes →

4 Check the LED Lamp voltage. Is it 0~2V? (While door closed)

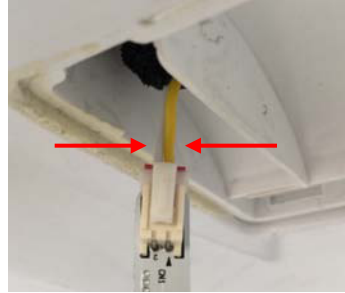

No → Change the Door S/W

Yes →

5 Check the LED Lamp voltage. Is it 12V? (While door open)

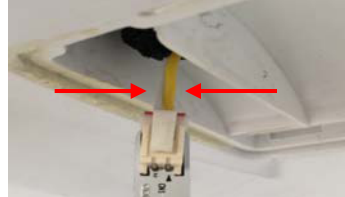

No → Change the LED Lamp

Yes →

6 Explain to customer

8-15. Freezer room upper lamp doesn't work

Symptom	Check Point
1. Freezer room upper lamp doesn't work	1. Check the Freezer door switch sticky 2. Check the door S/W resistance 3. Check the LED Lamp

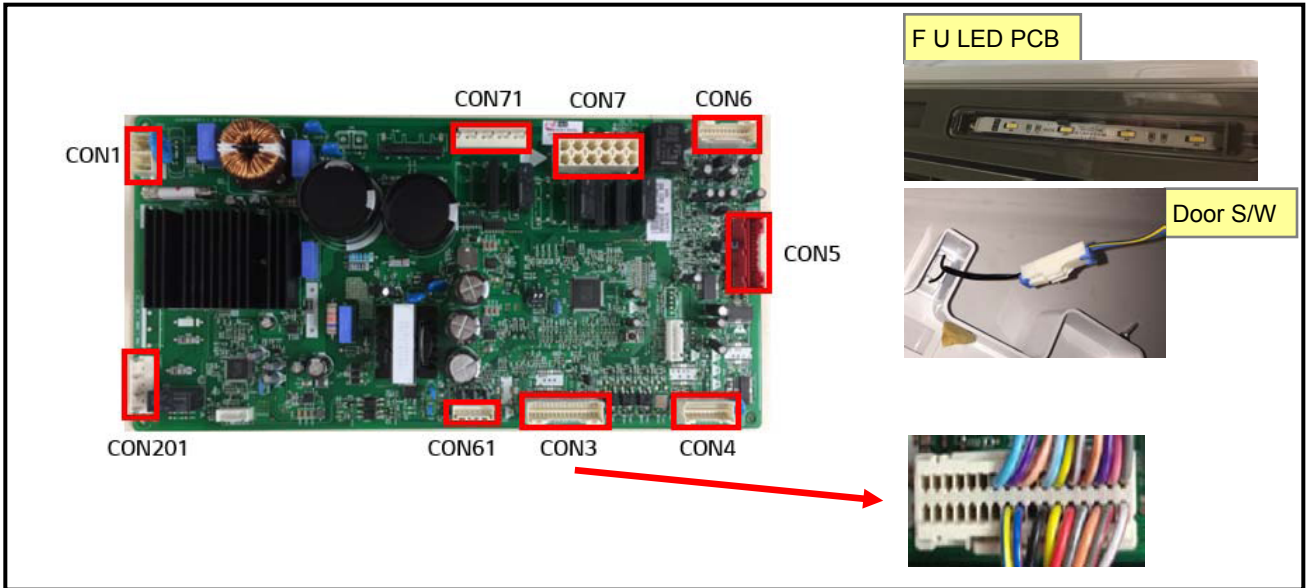

<table border="0"> <tr><td>1</td><td>BN/WH</td><td>ICING-FAN MOTOR (PWM)</td></tr> <tr><td>3</td><td>YL/BK</td><td>MOTEUR DE VENTILATEUR GIVRAGE (CC SANS BALAI)</td></tr> <tr><td>5</td><td>RD/YL</td><td></td></tr> <tr><td>7</td><td>YL/WH</td><td></td></tr> <tr><td>2</td><td>GY</td><td>C-FAN MOTOR (PWM)</td></tr> <tr><td>4</td><td>PK</td><td>MOTEUR DE VENTILATEUR C (CC SANS BALAI)</td></tr> <tr><td>6</td><td>WH/RD</td><td></td></tr> <tr><td>8</td><td>GY/RD</td><td></td></tr> <tr><td>9</td><td>PR/RD</td><td>BETA DUCT HEATER</td></tr> <tr><td>11</td><td>SB/BK</td><td>beta du chauffage</td></tr> <tr><td>10</td><td>PR</td><td></td></tr> <tr><td>12</td><td>BO/BL</td><td>F-FAN MOTOR (PWM)</td></tr> <tr><td>14</td><td>BO</td><td>MOTEUR DE VENTILATEUR F (CC SANS BALAI)</td></tr> <tr><td>16</td><td>GY/WH</td><td></td></tr> <tr><td>15</td><td>WH</td><td>R-SENSOR</td></tr> <tr><td>18</td><td>WH</td><td>CAPTEUR R</td></tr> <tr><td>17</td><td>BL/WH</td><td>F-SENSOR</td></tr> <tr><td>20</td><td>BL/WH</td><td>CAPTEUR F</td></tr> <tr><td>19</td><td>BN</td><td>D-SENSOR</td></tr> <tr><td>22</td><td>BN</td><td>CAPTEUR D</td></tr> <tr><td>21</td><td>YL/BL</td><td>FL DOOR SW</td></tr> <tr><td>24</td><td>SB</td><td>FU DOOR SW</td></tr> <tr><td>23</td><td>RD</td><td></td></tr> <tr><td>25</td><td>YL</td><td>REFRIGERATOR STEPPING MOTOR</td></tr> <tr><td>26</td><td>BL</td><td>MOTEUR PAS À PAS RÉFRIGÉRATEUR</td></tr> <tr><td>28</td><td>WH/BK</td><td></td></tr> <tr><td>13</td><td>BL/RD</td><td></td></tr> <tr><td>27</td><td>PR/WH</td><td></td></tr> <tr><td>29</td><td>PK/WH</td><td></td></tr> <tr><td>31</td><td>BK</td><td>FU LED LAMP</td></tr> <tr><td>32</td><td>SB/WH</td><td></td></tr> <tr><td>33</td><td>PK/WH</td><td>R LED LAMP</td></tr> </table>	1	BN/WH	ICING-FAN MOTOR (PWM)	3	YL/BK	MOTEUR DE VENTILATEUR GIVRAGE (CC SANS BALAI)	5	RD/YL		7	YL/WH		2	GY	C-FAN MOTOR (PWM)	4	PK	MOTEUR DE VENTILATEUR C (CC SANS BALAI)	6	WH/RD		8	GY/RD		9	PR/RD	BETA DUCT HEATER	11	SB/BK	beta du chauffage	10	PR		12	BO/BL	F-FAN MOTOR (PWM)	14	BO	MOTEUR DE VENTILATEUR F (CC SANS BALAI)	16	GY/WH		15	WH	R-SENSOR	18	WH	CAPTEUR R	17	BL/WH	F-SENSOR	20	BL/WH	CAPTEUR F	19	BN	D-SENSOR	22	BN	CAPTEUR D	21	YL/BL	FL DOOR SW	24	SB	FU DOOR SW	23	RD		25	YL	REFRIGERATOR STEPPING MOTOR	26	BL	MOTEUR PAS À PAS RÉFRIGÉRATEUR	28	WH/BK		13	BL/RD		27	PR/WH		29	PK/WH		31	BK	FU LED LAMP	32	SB/WH		33	PK/WH	R LED LAMP	<table border="1"> <thead> <tr> <th colspan="2"></th> <th colspan="2">S/W Resistance [Ω]</th> </tr> </thead> <tbody> <tr> <td rowspan="2">Door</td> <td>Open</td> <td colspan="2">Infinity</td> </tr> <tr> <td>Close</td> <td colspan="2">0</td> </tr> </tbody> </table> <table border="1"> <thead> <tr> <th colspan="2"></th> <th>Voltage [V]</th> </tr> </thead> <tbody> <tr> <td colspan="2">CON3 14th pin ~ 13th Pin</td> <td>12V</td> </tr> </tbody> </table> <table border="1"> <thead> <tr> <th>F-Door</th> <th>LED Lamp</th> <th>Voltage [V]</th> </tr> </thead> <tbody> <tr> <td>Open</td> <td>White ~ Black</td> <td>12V</td> </tr> <tr> <td>Close</td> <td>White ~ Black</td> <td>0~2V</td> </tr> </tbody> </table>			S/W Resistance [Ω]		Door	Open	Infinity		Close	0				Voltage [V]	CON3 14 th pin ~ 13 th Pin		12V	F-Door	LED Lamp	Voltage [V]	Open	White ~ Black	12V	Close	White ~ Black	0~2V
1	BN/WH	ICING-FAN MOTOR (PWM)																																																																																																																									
3	YL/BK	MOTEUR DE VENTILATEUR GIVRAGE (CC SANS BALAI)																																																																																																																									
5	RD/YL																																																																																																																										
7	YL/WH																																																																																																																										
2	GY	C-FAN MOTOR (PWM)																																																																																																																									
4	PK	MOTEUR DE VENTILATEUR C (CC SANS BALAI)																																																																																																																									
6	WH/RD																																																																																																																										
8	GY/RD																																																																																																																										
9	PR/RD	BETA DUCT HEATER																																																																																																																									
11	SB/BK	beta du chauffage																																																																																																																									
10	PR																																																																																																																										
12	BO/BL	F-FAN MOTOR (PWM)																																																																																																																									
14	BO	MOTEUR DE VENTILATEUR F (CC SANS BALAI)																																																																																																																									
16	GY/WH																																																																																																																										
15	WH	R-SENSOR																																																																																																																									
18	WH	CAPTEUR R																																																																																																																									
17	BL/WH	F-SENSOR																																																																																																																									
20	BL/WH	CAPTEUR F																																																																																																																									
19	BN	D-SENSOR																																																																																																																									
22	BN	CAPTEUR D																																																																																																																									
21	YL/BL	FL DOOR SW																																																																																																																									
24	SB	FU DOOR SW																																																																																																																									
23	RD																																																																																																																										
25	YL	REFRIGERATOR STEPPING MOTOR																																																																																																																									
26	BL	MOTEUR PAS À PAS RÉFRIGÉRATEUR																																																																																																																									
28	WH/BK																																																																																																																										
13	BL/RD																																																																																																																										
27	PR/WH																																																																																																																										
29	PK/WH																																																																																																																										
31	BK	FU LED LAMP																																																																																																																									
32	SB/WH																																																																																																																										
33	PK/WH	R LED LAMP																																																																																																																									
		S/W Resistance [Ω]																																																																																																																									
Door	Open	Infinity																																																																																																																									
	Close	0																																																																																																																									
		Voltage [V]																																																																																																																									
CON3 14 th pin ~ 13 th Pin		12V																																																																																																																									
F-Door	LED Lamp	Voltage [V]																																																																																																																									
Open	White ~ Black	12V																																																																																																																									
Close	White ~ Black	0~2V																																																																																																																									

Freezer room upper lamp doesn't work

1
Check the Freezer door switch.
Does it feel sticky?



Yes → Change the Door S/W

No

2
Check the door S/W resistance.
Is it correct compared with table?



Door S/W

No → Change the Door S/W

S/W Resistance [Ω]		
Door	Open	Infinity
	Close	1

Yes

3
Check the PCB Voltage.
Is CON3 14th pin ~ 13th pin
voltage 12V?



No → Change the PCB

	Voltage [V]
CON3 14 th pin ~ 13 th Pin	12V

Yes

4
Check the LED Lamp voltage
Is voltage 12V? (While door open)



No → Change the LED Lamp

Yes

5
Explain to customer

8-16. Poor cooling in Fresh food section

Symptom	Check Point
1. Poor cooling in Fresh food section	<ol style="list-style-type: none"> 1. Check the sensor resistance 2. Check the air flow 3. Check the air Temperature 4. Check the R-Damper motor voltage

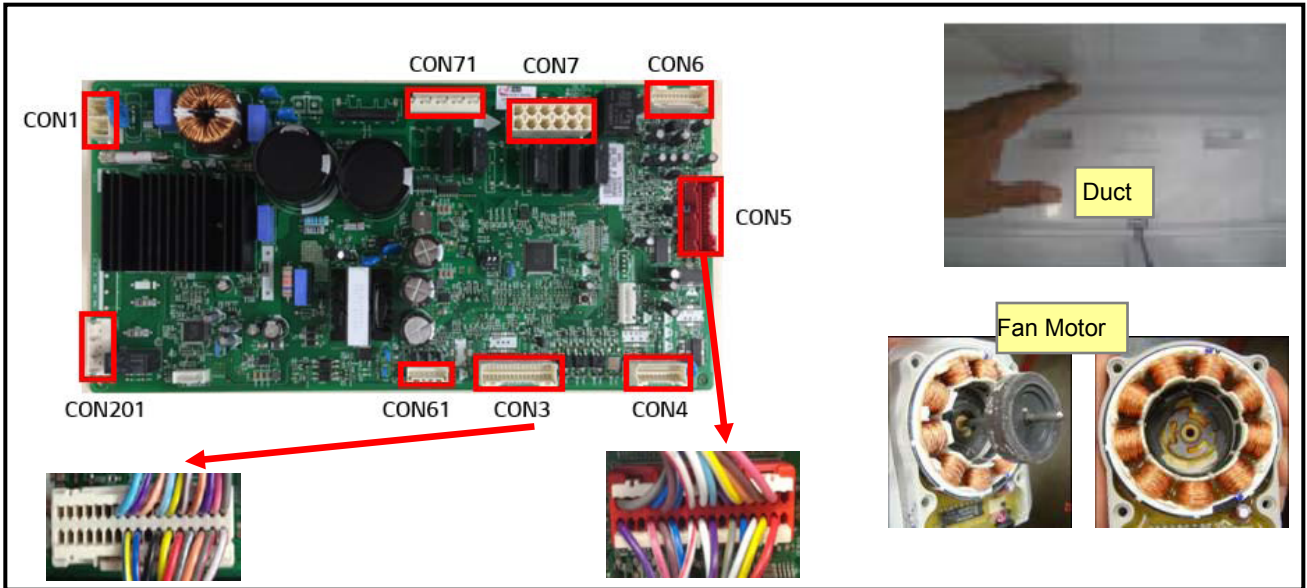

	<table border="1"> <thead> <tr> <th>CON5 18th pin ~ 17th Pin</th> <th>Resistance [Ω]</th> </tr> </thead> <tbody> <tr> <td>23°F / -5°C</td> <td>38k</td> </tr> <tr> <td>32°F / 0°C</td> <td>30k</td> </tr> <tr> <td>41°F / 5°C</td> <td>24k</td> </tr> <tr> <td>50°F / 10°C</td> <td>19.5k</td> </tr> <tr> <td>59°F / 15°C</td> <td>16k</td> </tr> <tr> <th>TEST MODE 1</th> <th>Voltage [V]</th> </tr> <tr> <td>CON3 8th pin ~ 5th Pin</td> <td>12V</td> </tr> <tr> <td>CON5 6th pin ~ 5th Pin</td> <td>0V<Voltage<5V</td> </tr> <tr> <td>CON5 7th pin ~ 5th Pin</td> <td>0V<Voltage<5V</td> </tr> </tbody> </table>	CON5 18 th pin ~ 17 th Pin	Resistance [Ω]	23°F / -5°C	38k	32°F / 0°C	30k	41°F / 5°C	24k	50°F / 10°C	19.5k	59°F / 15°C	16k	TEST MODE 1	Voltage [V]	CON3 8 th pin ~ 5 th Pin	12V	CON5 6 th pin ~ 5 th Pin	0V<Voltage<5V	CON5 7 th pin ~ 5 th Pin	0V<Voltage<5V
CON5 18 th pin ~ 17 th Pin	Resistance [Ω]																				
23°F / -5°C	38k																				
32°F / 0°C	30k																				
41°F / 5°C	24k																				
50°F / 10°C	19.5k																				
59°F / 15°C	16k																				
TEST MODE 1	Voltage [V]																				
CON3 8 th pin ~ 5 th Pin	12V																				
CON5 6 th pin ~ 5 th Pin	0V<Voltage<5V																				
CON5 7 th pin ~ 5 th Pin	0V<Voltage<5V																				
<table border="1"> <thead> <tr> <th>Duct</th> <th>Status</th> </tr> </thead> <tbody> <tr> <td>Air Flow</td> <td>Windy</td> </tr> <tr> <td>Air Temperature</td> <td>Cold</td> </tr> </tbody> </table>	Duct	Status	Air Flow	Windy	Air Temperature	Cold															
Duct	Status																				
Air Flow	Windy																				
Air Temperature	Cold																				

Poor cooling in Fresh food section

1 Check the sensor resistance.



CON5 18 th pin ~ 17 th Pin	Resistance [\square]
23°F / -5°C	38k
32°F / 0°C	30k
41°F / 5°C	24k
50°F / 10°C	19.5k
59°F / 15°C	16k

2 Reset the unit and Input Test1 Mode (Push the button 1 time)



3 Open the fresh food door and Check the air flow Damper?



Test Mode	Damper state	SVC Action
1 Mode	Closed	Damper is normal. (Go to the 7)
2 Mode	Open	
1, 2 mode	Not working	Change the damper

Test Point	Result	SVC Action
(1) To (2)	270 ~ 330Ω	It's normal
	Other	Change damper
(3) To (4)	270 ~ 330Ω	It's normal
	Other	Change damper



Check the damper
Go to 5

Yes

4 Check the air temperature.
Is it cold?

No

Check the Compressor and sealed system

Yes

Go to 7

5 Check the Fan Motor voltage
Is Fan Motor voltage right?

No

Replace Main PCB



TEST MODE 1	Voltage [V]
CON3 8 th pin ~ 5 th Pin	12V
CON5 7 th pin ~ 5 th Pin	0V<Voltage<5V

Yes

6 Check the Fan Motor voltage
Is Fan Feed Back voltage 0V, 5V?

Yes

Change the motor

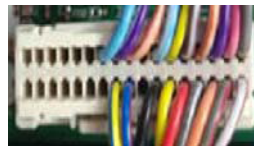

TEST MODE 1	Voltage [V]
CON5 6 th pin ~ 5 th Pin	0V<Voltage<5V

No

7 Explain to customer

8-17. Poor cooling in Freezer compartment

Symptom	Check Point
1. Poor cooling in Freezer compartment	<ol style="list-style-type: none"> 1. Check the sensor resistance 2. Check the air flow 3. Check the air Temperature 4. Check the Fan motor sticky 5. Check the Fan motor voltage

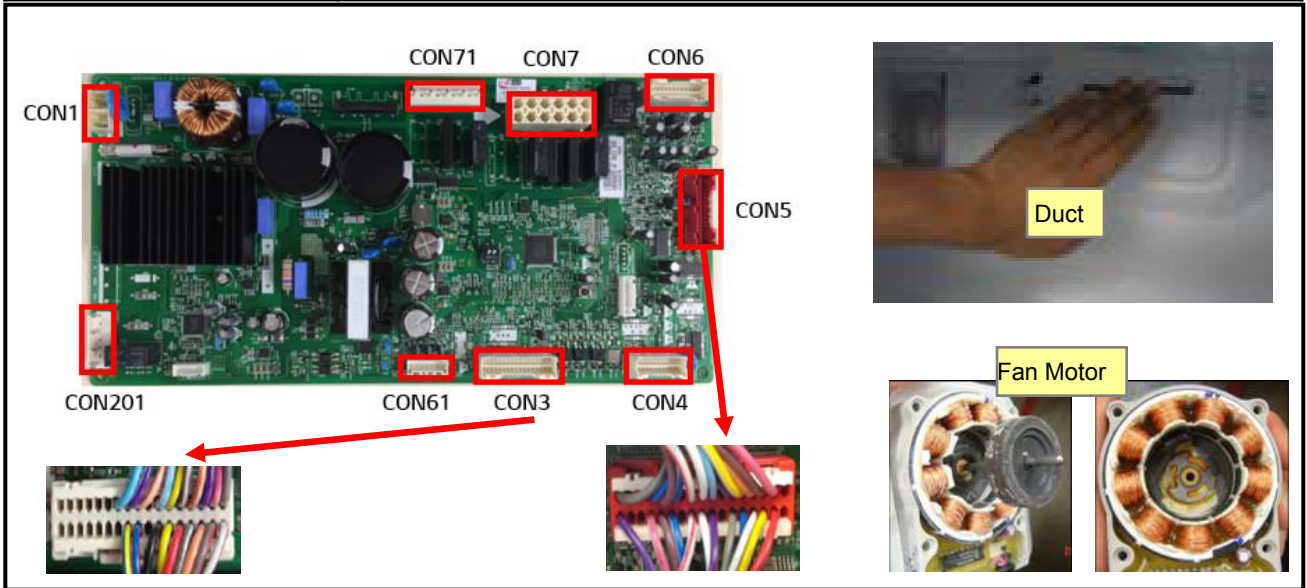

	<table border="1"> <thead> <tr> <th>CON5 12th pin ~ 11th Pin</th> <th>Resistance [Ω]</th> </tr> </thead> <tbody> <tr> <td>-22°F / -30°C</td> <td>40k</td> </tr> <tr> <td>-13°F / -25°C</td> <td>30k</td> </tr> <tr> <td>-4°F / -20°C</td> <td>23k</td> </tr> <tr> <td>-13°F / -25°C</td> <td>17k</td> </tr> <tr> <td>14°F / -10°C</td> <td>13k</td> </tr> <tr> <td>23°F / -5°C</td> <td>10k</td> </tr> <tr> <td>32°F / 0°C</td> <td>8k</td> </tr> </tbody> </table>	CON5 12 th pin ~ 11 th Pin	Resistance [Ω]	-22°F / -30°C	40k	-13°F / -25°C	30k	-4°F / -20°C	23k	-13°F / -25°C	17k	14°F / -10°C	13k	23°F / -5°C	10k	32°F / 0°C	8k
CON5 12 th pin ~ 11 th Pin	Resistance [Ω]																
-22°F / -30°C	40k																
-13°F / -25°C	30k																
-4°F / -20°C	23k																
-13°F / -25°C	17k																
14°F / -10°C	13k																
23°F / -5°C	10k																
32°F / 0°C	8k																
<table border="1"> <thead> <tr> <th>Duct</th> <th>Status</th> </tr> </thead> <tbody> <tr> <td>Air Flow</td> <td>Windy</td> </tr> <tr> <td>Air Temperature</td> <td>Cold</td> </tr> </tbody> </table>	Duct	Status	Air Flow	Windy	Air Temperature	Cold	<table border="1"> <thead> <tr> <th>TEST MODE 1</th> <th>Voltage [V]</th> </tr> </thead> <tbody> <tr> <td>CON3 8th pin ~ 5th Pin</td> <td>12V</td> </tr> <tr> <td>CON5 6th pin ~ 5th Pin</td> <td>0V<Voltage<5V</td> </tr> <tr> <td>CON5 7th pin ~ 5th Pin</td> <td>0V<Voltage<5V</td> </tr> </tbody> </table>	TEST MODE 1	Voltage [V]	CON3 8 th pin ~ 5 th Pin	12V	CON5 6 th pin ~ 5 th Pin	0V<Voltage<5V	CON5 7 th pin ~ 5 th Pin	0V<Voltage<5V		
Duct	Status																
Air Flow	Windy																
Air Temperature	Cold																
TEST MODE 1	Voltage [V]																
CON3 8 th pin ~ 5 th Pin	12V																
CON5 6 th pin ~ 5 th Pin	0V<Voltage<5V																
CON5 7 th pin ~ 5 th Pin	0V<Voltage<5V																

Poor cooling in Freezer compartment

1 Check the sensor resistance.

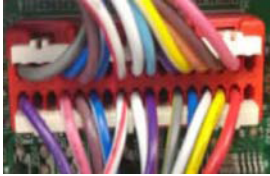

CON7 17 th pin ~ 20 th pin	Resistance [Ω]
-22°F / -30°C	40k
-13°F / -25°C	30k
-4°F / -20°C	23k
-13°F / -25°C	17k
14°F / -10°C	13k
23°F / -5°C	10k
32°F / 0°C	8k

2 Reset the unit and Input Test1 Mode (Push the button 1 time)



3 Open the fresh food door and Check the air flow. Windy?

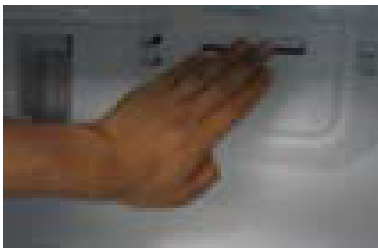

Check the F Fan Motor
Go to 5

4 Check the air temperature. Is it cold?

Check the Compressor and sealed system

5 Check the Fan motor. Rotate fan using hand. It feel sticky?

Change the Fan motor

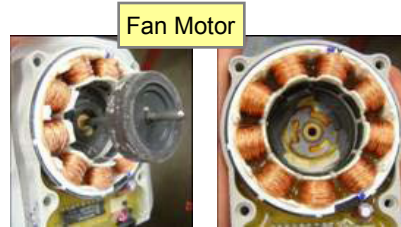

6 Check the Fan Motor voltage
Is Fan Motor voltage right ?



TEST MODE 1	Voltage [V]
CON3 8 th pin ~ 5 th Pin	12V
CON5 7 th pin ~ 5 th Pin	0V<Voltage<5V

No → Replace Main PCB

Yes

7 Check the Fan Motor voltage
Is Fan Feed Back voltage right?

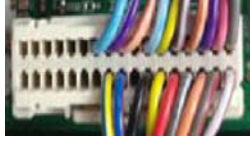

TEST MODE 1	Voltage [V]
CON5 6 th pin ~ 5 th Pin	0V<Voltage<5V

No → Change the motor

Yes

8 Explain to customer

8-17. Over cooling in Freezer compartment

Symptom	Check Point
1. Over cooling in Freezer compartment	1. Check the sensor resistance 2. Check the air flow 3. Check the air Temperature 4. Check the Fan motor sticky 5. Check the Fan motor voltage

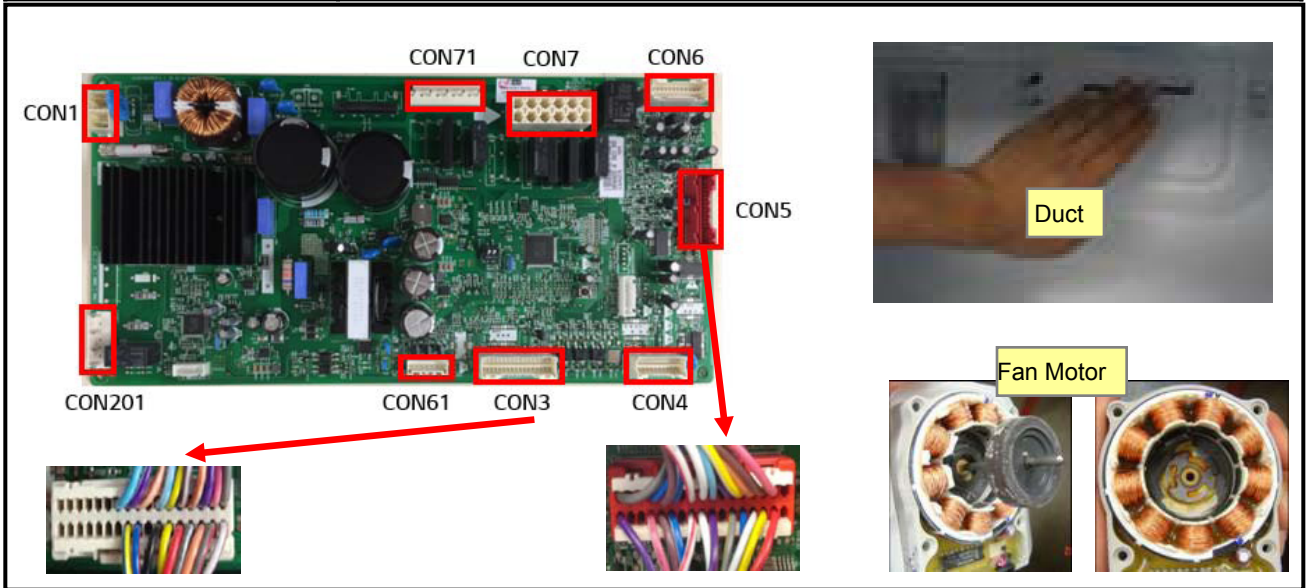

	<table border="1"> <thead> <tr> <th>CON5 12th pin ~ 11th Pin</th> <th>Resistance [Ω]</th> </tr> </thead> <tbody> <tr> <td>-22°F / -30°C</td> <td>40k</td> </tr> <tr> <td>-13°F / -25°C</td> <td>30k</td> </tr> <tr> <td>-4°F / -20°C</td> <td>23k</td> </tr> <tr> <td>-13°F / -25°C</td> <td>17k</td> </tr> <tr> <td>14°F / -10°C</td> <td>13k</td> </tr> <tr> <td>23°F / -5°C</td> <td>10k</td> </tr> <tr> <td>32°F / 0°C</td> <td>8k</td> </tr> </tbody> </table>	CON5 12 th pin ~ 11 th Pin	Resistance [Ω]	-22°F / -30°C	40k	-13°F / -25°C	30k	-4°F / -20°C	23k	-13°F / -25°C	17k	14°F / -10°C	13k	23°F / -5°C	10k	32°F / 0°C	8k
CON5 12 th pin ~ 11 th Pin	Resistance [Ω]																
-22°F / -30°C	40k																
-13°F / -25°C	30k																
-4°F / -20°C	23k																
-13°F / -25°C	17k																
14°F / -10°C	13k																
23°F / -5°C	10k																
32°F / 0°C	8k																
<table border="1"> <tbody> <tr> <td>Duct</td> <td>Status</td> </tr> <tr> <td>Air Flow</td> <td>Windy</td> </tr> <tr> <td>Air Temperature</td> <td>Cold</td> </tr> </tbody> </table>	Duct	Status	Air Flow	Windy	Air Temperature	Cold	<table border="1"> <thead> <tr> <th>TEST MODE 1</th> <th>Voltage [V]</th> </tr> </thead> <tbody> <tr> <td>CON3 8th pin ~ 5th Pin</td> <td>12V</td> </tr> <tr> <td>CON5 6th pin ~ 5th Pin</td> <td>0V<Voltage<5V</td> </tr> <tr> <td>CON5 7th pin ~ 5th Pin</td> <td>0V<Voltage<5V</td> </tr> </tbody> </table>	TEST MODE 1	Voltage [V]	CON3 8 th pin ~ 5 th Pin	12V	CON5 6 th pin ~ 5 th Pin	0V<Voltage<5V	CON5 7 th pin ~ 5 th Pin	0V<Voltage<5V		
Duct	Status																
Air Flow	Windy																
Air Temperature	Cold																
TEST MODE 1	Voltage [V]																
CON3 8 th pin ~ 5 th Pin	12V																
CON5 6 th pin ~ 5 th Pin	0V<Voltage<5V																
CON5 7 th pin ~ 5 th Pin	0V<Voltage<5V																

Over cooling in Freezer compartment

1 Check the sensor resistance.

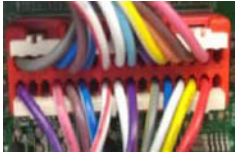

CON5 12 th pin ~ 11 th Pin	Resistance [Ω]
-22°F / -30°C	40k
-13°F / -25°C	30k
-4°F / -20°C	23k
-13°F / -25°C	17k
14°F / -10°C	13k
23°F / -5°C	10k
32°F / 0°C	8k

2 Check the air flow in test mode 1 & 3
(Push the button 1 or 3 time)



Test1	Air Flow
Test3	No Air Flow

OK → Explain to customer

NG

3 Check the Fan motor.
Rotate fan using hand.
It feel sticky?

Yes → Change the Fan motor

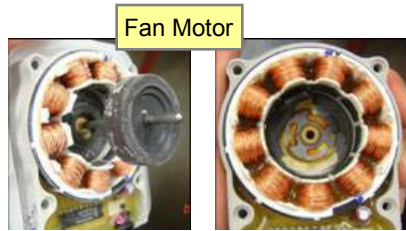

No

4 Change the Main PCB

8-18. Home Bar Heater do not work

Symptom	Check Point
1. Home Bar do not work	1. Check the Main PCB 2. Check the Home Bar Heater

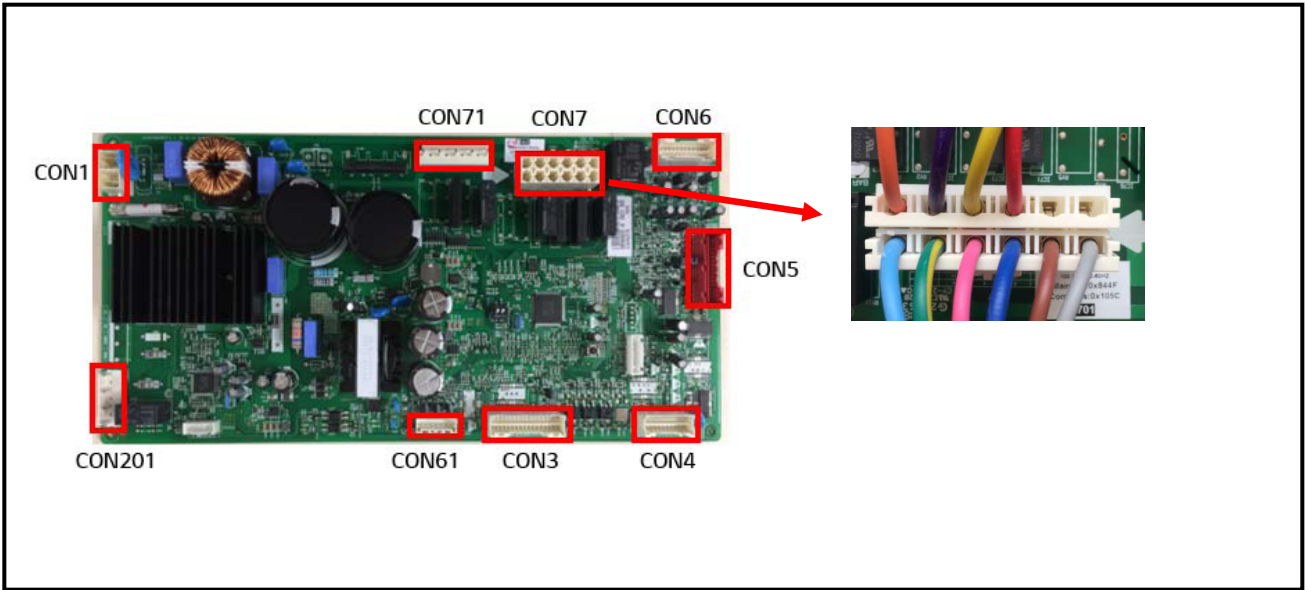

CON1	Pin
GY	1
BN	2
BL	3
PK	4
GNV1	5
SB	6
	7
RD	8
RD	9
YL	10
PR	11
BO	12

CON7	Pin
	1-4
BL	5
BL	6

Part	Resistance [Ω]
Defrost Heater	1912~2314

TEST MODE 3	Voltage [V]
CON7 10 th pin ~ 3 th Pin	112V ~ 116V

TEST MODE 1	Voltage [V]
CON7 10 th pin ~ 3 th Pin	0V

Home Bar Heater do not work

1
Check the Door gasket .
Is door gasket damaged?

Yes → Replace the Door gasket

No

3
Is the connector loose?

Yes → Connect the housing

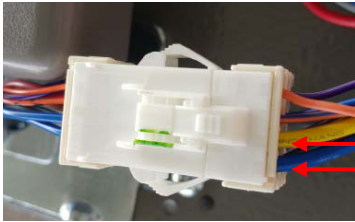

NO

3
Check Heater part.
Heater resistance
1912~2314 Ω?

NO → Change The door

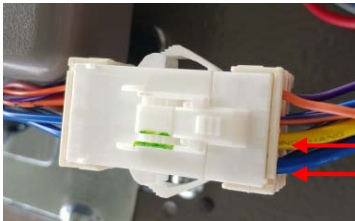

Yes

4 Input Test 3 Mode
(Push the button 3 times)
Check the Heater Voltage.
Is voltage 112~116V?

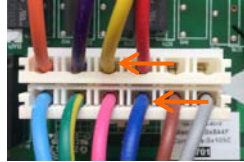

TEST MODE 3	Voltage [V]
CON7 10 th pin ~ 3 th Pin	112V ~ 116V

NO → Replace Main PCB

Yes

5 Input Test 1 Mode
(Push the button 1 times)
Check the Heater Voltage.
Is voltage 0V?

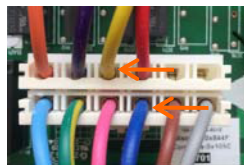

TEST MODE 1	Voltage [V]
CON7 10 th pin ~ 3 th Pin	0V

No → Replace Main PCB

Yes

6 Explain to customer

8-19. GID Heater do not work

Symptom	Check Point
1. GID HTR do not work	1. Check the Main PCB 2. Check the Home Bar Heater

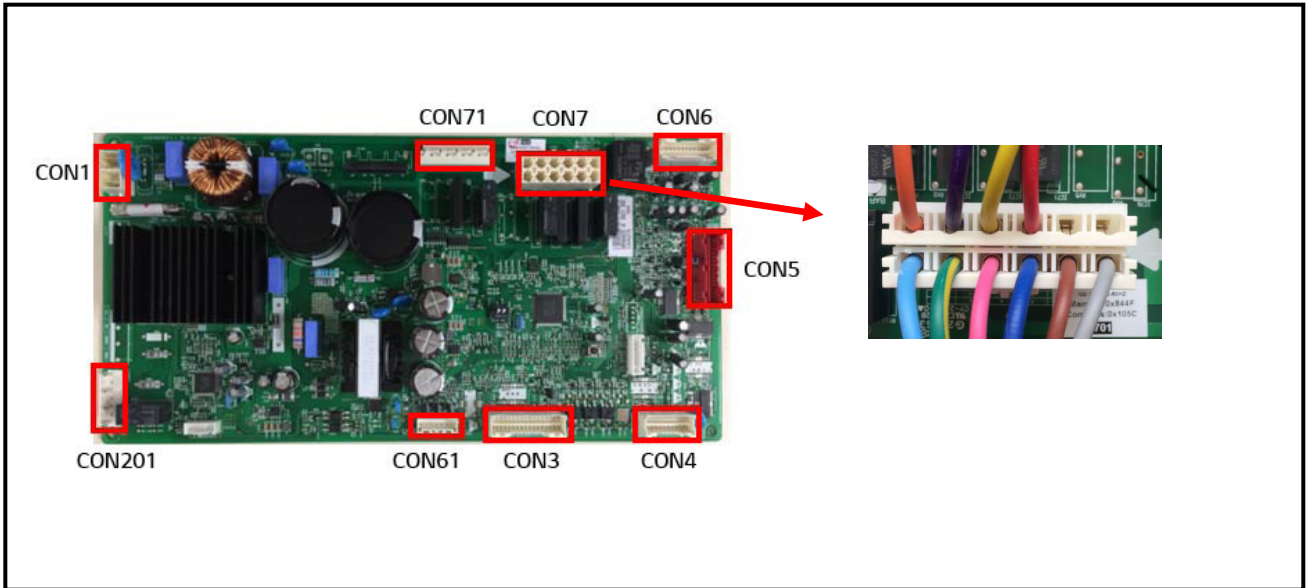

Pin	Color
1	GY
2	BN
3	BL
4	PK
5	GNYL
6	SB
7	
8	
9	RD
10	YL
11	PR
12	BO

Part	Resistance [Ω]
Defrost Heater	1912~2314

TEST MODE 3	Voltage [V]
CON7 11 th pin ~ 3 th Pin	112V ~ 116V

TEST MODE 1	Voltage [V]
CON7 11 th pin ~ 3 th Pin	0V

GID Heater do not work

1
Check the Door gasket .
Is door gasket damaged?

Yes → Replace the Door gasket

No

3
Is the connector loose?

Yes → Connect the housing

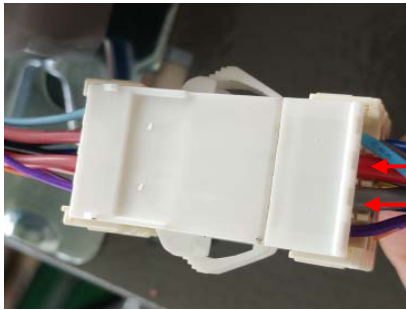

NO

3
Check Heater part.
Heater resistance
3072~3534 Ω?

NO → Change The door

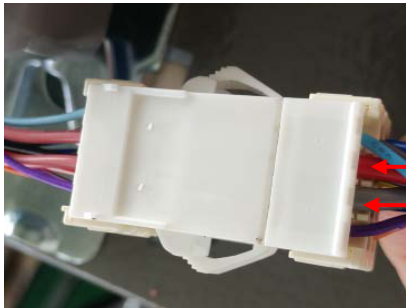

Yes

4 Input Test 3 Mode
(Push the button 3 times)
Check the Heater Voltage.
Is voltage 112~116V?

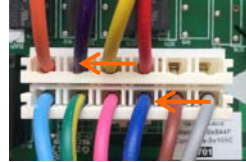

TEST MODE 3	Voltage [V]
CON7 11 th pin ~ 3 th Pin	112V ~ 116V

NO → Replace Main PCB

Yes

5 Input Test 1 Mode
(Push the button 1 times)
Check the Heater Voltage.
Is voltage 0V?

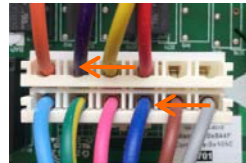

TEST MODE 1	Voltage [V]
CON7 11 th pin ~ 3 th Pin	0V

No → Replace Main PCB

Yes

6 Explain to customer

8-20. Hygiene fan doesn't work

Symptom	Check Point
1. Hygiene fan doesn't work	1. Check Hygiene Fan motor voltage 2. Main PCB

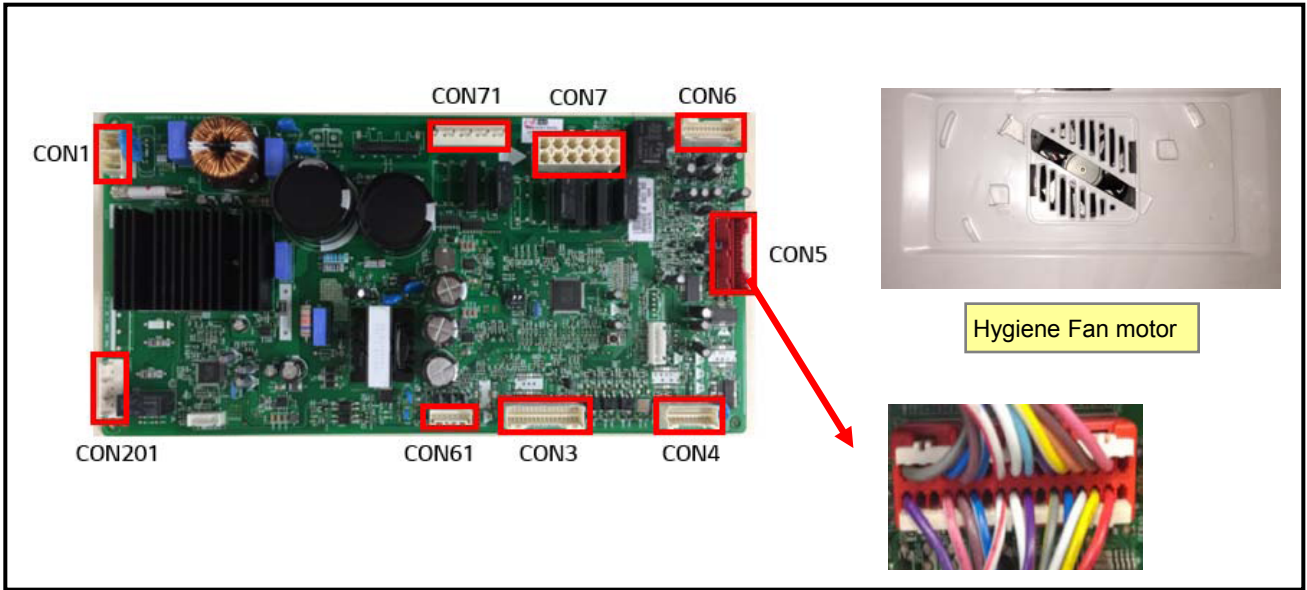

Component	Pin	Voltage [V]
H/F FAN MOTOR (M)	GY 1	12V
MOTEUR H/F	PR 2	
ROOM LED MODULE (MODULE LED PIÈCE)	BLRD 7	
	PKWH 8	
D-SENSOR (CAPTEUR D)	BN 9	
F-SENSOR (CAPTEUR F)	BN 10	
	BLWH 11	
	BLWH 12	
PANTRY-SENSOR (DÉTECTEUR DE COMPTOIR)	13-14	
	WHRD 15	
	WHRD 16	
R-SENSOR (CAPTEUR R)	WH 17	
	WH 18	
BETA DUCT HEATER (BETA DU CHAUFFAGE)	SEBK 19	
	PRRD 20	
	21-22	
F WATER PIPE HEATER (RECHAUFFEUR CONDUITE D'EAU)	PRWH 23	
	GYYL 24	
PANTRY STEPPING MOTOR (MOTEUR PAS À PAS DE COMPTOIR) (M)	YUWH 25	
	BO 27	
	BNWH 29	
	PK 31	
	BL 26	
REFRIGERATOR STEPPING MOTOR (MOTEUR PAS À PAS RÉFRIGÉRATEUR) (M)	WHBK 28	
	YL 30	
	RD 32	
	33-34	
	CON5	

Hygiene fan doesn't work

1

Choose the Hygiene Max in display
Check the PCB Voltage.
Is CON6 2nd pin ~ 5th pin
voltage 12V?

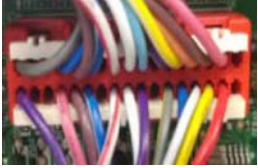

	Voltage [V]
CON5 2 th pin ~ 1 th Pin	12V

No

Change the
PCB

Yes

2

Is the connector loose?

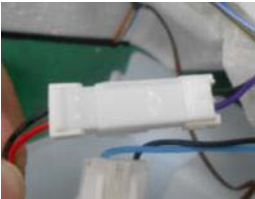

Yes

Connect the
housing

No

3

Check the Hygiene voltage
Is voltage 12V? (While door open)

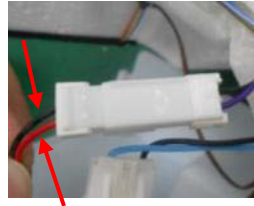

No

Change the
Fan motor

Yes

4

Explain to customer

8-20. Wi-Fi modem doesn't work

Symptom	Check Point
1. Wi-Fi modem doesn't work	<ol style="list-style-type: none"> 1. Check connector 2. Display PCB 3. Wi-Fi modem PCB

Display PCB

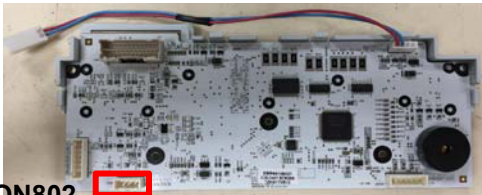

CON802



CON802

Wi-Fi PCB

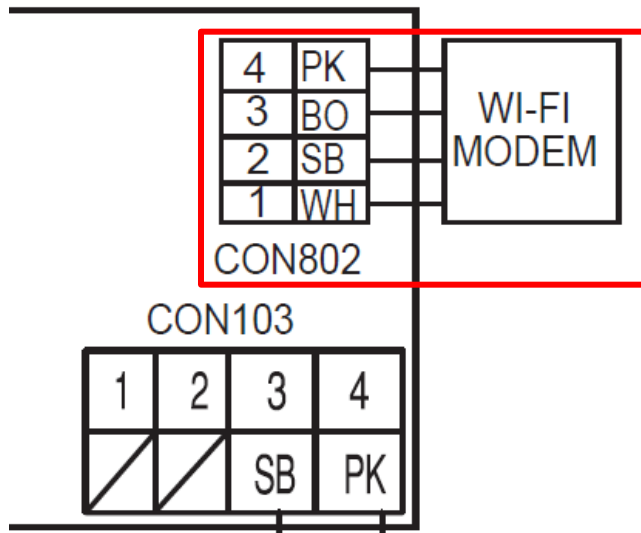

Wi-Fi ON	Voltage [V]
CON802 1 st pin ~ 4 th pin	5V
CON802 2 nd pin ~ 4 th pin	Not 0V, 5V
CON802 3 rd pin ~ 4 th pin	Not 0V, 5V

Wi-Fi modem doesn't work

1

Choose the connectors in the display and lead wire. Is it loose ?

Yes

Connect the housing

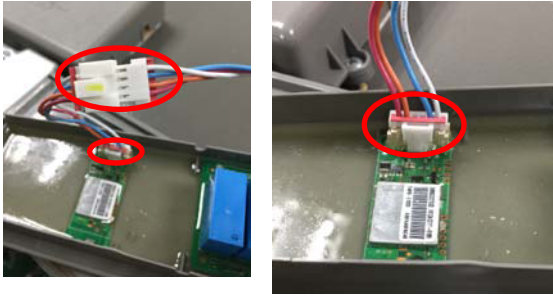

No

2

Check the Wi-Fi PCB output?
(While Wi-Fi function is on)

No

Change
Wi-Fi
modem

Wi-Fi modem	Voltage [V]
5 th pin ~ 6 th pin	Not 0V, 5V



Yes

3

Check the Display PCB output?
(While Wi-Fi function is on)

No

Change the
display

Display CON802	Voltage [V]
1 st pin ~ 4 th pin	5V
2 nd pin ~ 4 th pin	Not 0V, 5V

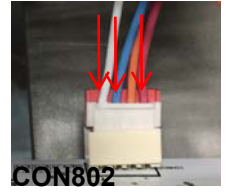

Yes

4

Explain to customer

10. REFERENCE

10-1 TEST MODE and Removing TPA

1. How to enter the TEST MODE

Push the test button on the Main PCB to enter the TEST MODE.



Main PWB

* 1 time : Comp / Damper / All FAN on
(Everything is displayed)

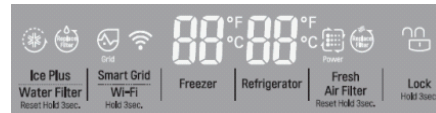

* 2 times : Damper closed
(22 22 displayed)



* 3 times : Forced defrost mode
(33 33 displayed)



2. How to remove Terminal Position Assurance (TPA)

> A P T C A <

> A P T C D <



※ After measure the values, you should put in the TPA again.

10-2 TEMPERATRUE CHART - FRZ AND ICING SENSOR

TEMP	RESISTANCE	VOLTAGE
-39°F (-40°C)	73.29 ☒	4.09 V
-30°F (-35°C)	53.63 ☒	3.84 V
-21°F (-30°C)	39.66 ☒	3.55 V
-13°F (-25°C)	29.62 ☒	3.23 V
-4°F (-20°C)	22.33 ☒	2.89 V
5°F (-15°C)	16.99 ☒	2.56 V
14°F (-10°C)	13.05 ☒	2.23 V
23°F (-5°C)	10.10 ☒	1.92 V
32°F (0°C)	7.88 ☒	1.63 V
41°F (5°C)	6.19 ☒	1.38 V
50°F (10°C)	4.91 ☒	1.16 V
59°F (15°C)	3.91 ☒	0.97 V
68°F (20°C)	3.14 ☒	0.81 V
77°F (25°C)	2.54 ☒	0.67 V
86°F (30°C)	2.07 ☒	0.56 V
95°F (35°C)	1.69 ☒	0.47 V
104°F (40°C)	1.39 ☒	0.39 V

10-3 TEMPERATRUE CHART - REF AND DEF SENSOR

TEMP	RESISTANCE	VOLTAGE
-39°F (-40°C)	225.1 ☒	4.48 V
-30°F (-35°C)	169.8 ☒	4.33 V
-21°F (-30°C)	129.3 ☒	4.16 V
-13°F (-25°C)	99.30 ☒	3.95 V
-4°F (-20°C)	76.96 ☒	3.734 V
5°F (-15°C)	60.13 ☒	3.487 V
14°F (-10°C)	47.34 ☒	3.22 V
23°F (-5°C)	37.55 ☒	2.95 V
32°F (0°C)	30 ☒	2.67 V
41°F (5°C)	24.13 ☒	2.40 V
50°F (10°C)	19.53 ☒	2.14 V
59°F (15°C)	15.91 ☒	1.89 V
68°F (20°C)	13.03 ☒	1.64 V
77°F (25°C)	10.74 ☒	1.45 V
86°F (30°C)	8.89 ☒	1.27 V
95°F (35°C)	7.40 ☒	1.10 V
104°F (40°C)	6.20 ☒	0.96 V

10-4 How to check the Fan-Error

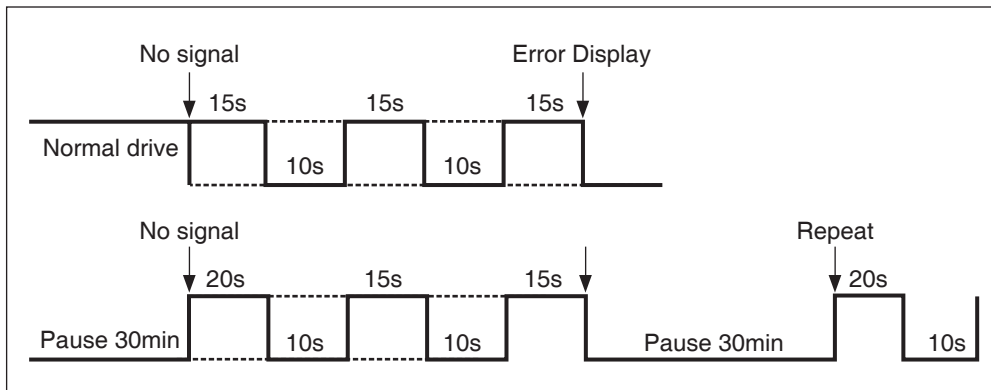

(1) EBR650027**

After sending a signal to the fan, the MICOM checks the BLDC fan motor's lock status. If there is no feedback signal from the BLDC fan, the fan motor stops for 10 seconds and then is powered again for 15 seconds. To determine that there is a fan motor malfunction, this process is repeated 3 times. If the fan motor is determined to be defective, the error code will be shown in the display for 30 minutes. At this point, the process will be repeated until the fan motor operates normally. If normal operation is achieved, the error display is erased and the MICOM is reset automatically.

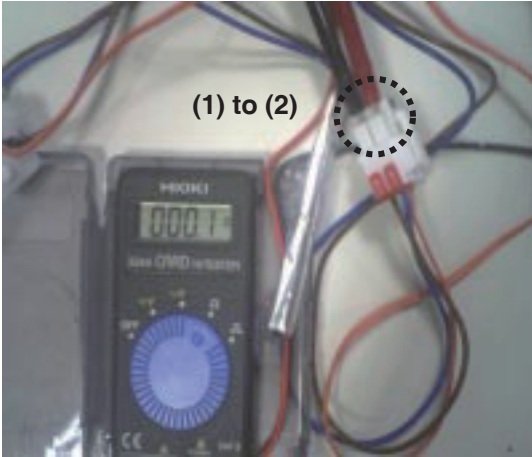

11. COMPONENT TESTING INFORMATION

11-1 Defrost Controller Assembly

<p>Function</p>	<p>The controller assembly is made up of two different kinds of parts. The fuse and the sensor. To determine if these parts are defective, check for resistance. The fuse will cut power to the defrost heater at very high temperatures.</p>													
<p>How to Measure (Fuse-M)</p>		<p>Set a ohmmeter to the 2 housing pin. Measure the 2 pin connected to Fuse-M. If the ohmmeter indicate below 0.1ohm fuse-m is a good condition, But if infinite the part is bad.</p>												
<p>How to Measure (Sensor)</p>		<p>Set a ohmmeter to The 2housing pin. Measure the 2 pin connected to Sensor. If the ohmmeter indicate 11KΩ (at room temperature) Sensor is good. When check the ohm at other temperatures Check the sensor manual.</p>												
<p>Standard</p>	<table border="1" style="margin-left: auto; margin-right: auto;"> <thead> <tr> <th colspan="2">Fuse-M (at all temperature)</th> </tr> <tr> <th>Test Point</th> <th>Result</th> </tr> </thead> <tbody> <tr> <td>(1) to (2)</td> <td>0 ~ 0.1Ω</td> </tr> </tbody> </table>	Fuse-M (at all temperature)		Test Point	Result	(1) to (2)	0 ~ 0.1 Ω	<table border="1" style="margin-left: auto; margin-right: auto;"> <thead> <tr> <th colspan="2">Sensor (at room temperature)</th> </tr> <tr> <th>Test Point</th> <th>Result</th> </tr> </thead> <tbody> <tr> <td>(1) to (2)</td> <td>11KΩ</td> </tr> </tbody> </table>	Sensor (at room temperature)		Test Point	Result	(1) to (2)	11K Ω
Fuse-M (at all temperature)														
Test Point	Result													
(1) to (2)	0 ~ 0.1 Ω													
Sensor (at room temperature)														
Test Point	Result													
(1) to (2)	11K Ω													

11-2 Sheath Heater

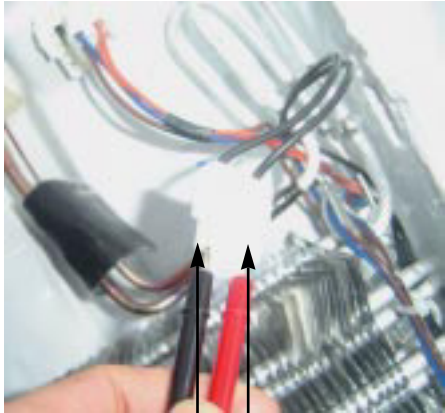
<p>Function</p>	<p>Sheath heater is a part for defrost. All heating wire is connected to only one line. To check if the part is defective, check the resistance.</p>				
<p>How to Measure</p>	<div style="display: flex; justify-content: space-around;">   </div> <p style="text-align: center;">(1) (2)</p> <p>Set a ohmmeter connect to The 2 housing pin. Measure the 2 pin connected to Sheath Heater. If the ohmmeter indicate $(V^{\circ}\delta V)/Watt=R$ is good condition, ex) when watt=350w, voltage=115v $R=(115^{\circ}\delta 115)/350=38\Omega$ But if the ohm meter indicate infinity the Sheath heater is bad.</p>				
<p>Standard</p>	<p style="text-align: center;">Sheath heater (at all temperature)</p> <table border="1" style="margin-left: auto; margin-right: auto;"> <thead> <tr> <th>Test Point</th> <th>Result</th> </tr> </thead> <tbody> <tr> <td>(1) to (2)</td> <td>34 ~ 42Ω</td> </tr> </tbody> </table>	Test Point	Result	(1) to (2)	34 ~ 42 Ω
Test Point	Result				
(1) to (2)	34 ~ 42 Ω				

11-3 Door Heater Assembly

Function	The heater is designed to prevent the raising dew from door.				
How to Measure					
Standard	<table border="1" data-bbox="457 1449 873 1540"><thead><tr><th data-bbox="457 1449 664 1491">Test Point</th><th data-bbox="664 1449 873 1491">Result</th></tr></thead><tbody><tr><td data-bbox="457 1491 664 1540">(1) to (2)</td><td data-bbox="664 1491 873 1540">1.9-2.2KΩ</td></tr></tbody></table>	Test Point	Result	(1) to (2)	1.9-2.2KΩ
Test Point	Result				
(1) to (2)	1.9-2.2KΩ				

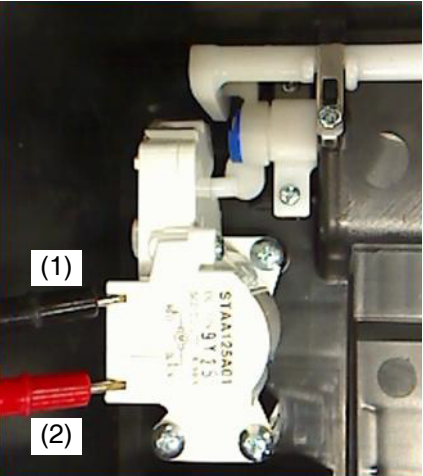

11-5 Dispenser DC Motor

Function	- Dispenser DC Motor : When customer push the dispenser button, Pull duct door and abstract from ice bank.						
How to Measure	<div style="text-align: center;">  <p>Dispenser DC Motor</p> </div>						
Standard	<table border="1" style="margin-left: auto; margin-right: auto;"> <thead> <tr> <th colspan="2" style="text-align: center;">Dispenser DC Motor</th> </tr> <tr> <th style="text-align: center;">Test Points</th> <th style="text-align: center;">Result</th> </tr> </thead> <tbody> <tr> <td style="text-align: center;">(1) to (2)</td> <td style="text-align: center;">9.9 ~ 12.1 \boxtimes</td> </tr> </tbody> </table>	Dispenser DC Motor		Test Points	Result	(1) to (2)	9.9 ~ 12.1 \boxtimes
Dispenser DC Motor							
Test Points	Result						
(1) to (2)	9.9 ~ 12.1 \boxtimes						

11-7 Damper

<p>Function</p>	<p>The damper supplies cold air from the freezer to the chill room using the damper plate. The chill room is colder when the damper plate is open. When the damper is closed the chill rooms temperature will rise.</p>																													
<p>How to Measure</p>	<div style="display: flex; justify-content: space-around;"> <div data-bbox="462 510 787 861"> <p>Table(1): 결선도(Wiring)</p> </div> <div data-bbox="876 510 1356 819"> <p>Table(2): 2-2상 여자순서(CW Rotation)</p> <table border="1"> <thead> <tr> <th rowspan="2">Housing No. & L/Wire Color</th> <th colspan="4">Step</th> </tr> <tr> <th>1</th> <th>2</th> <th>3</th> <th>4</th> </tr> </thead> <tbody> <tr> <td>1- Blue (A)</td> <td>+</td> <td>-</td> <td>-</td> <td>+</td> </tr> <tr> <td>2- Red (B)</td> <td>+</td> <td>+</td> <td>-</td> <td>-</td> </tr> <tr> <td>3- White (A)</td> <td>-</td> <td>+</td> <td>+</td> <td>-</td> </tr> <tr> <td>4- Yellow (B)</td> <td>-</td> <td>-</td> <td>+</td> <td>+</td> </tr> </tbody> </table> </div> </div> <p style="text-align: center;">< Damper Circuit ></p> <div style="display: flex; justify-content: space-around;"> <div data-bbox="365 1021 665 1212"> </div> <div data-bbox="1031 946 1421 1223"> <p>Check the (1), (3)</p> </div> </div> <p style="text-align: center;">< extension ></p> <div style="display: flex; justify-content: space-around;"> <div data-bbox="365 1330 771 1617"> <p>Check the (1), (2)</p> </div> <div data-bbox="1031 1340 1461 1617"> <p>Check the (3), (4)</p> </div> </div> <p>Check to see if there is electrical current, if there is resistance the damper is good.</p>	Housing No. & L/Wire Color	Step				1	2	3	4	1- Blue (A)	+	-	-	+	2- Red (B)	+	+	-	-	3- White (A)	-	+	+	-	4- Yellow (B)	-	-	+	+
Housing No. & L/Wire Color	Step																													
	1	2	3	4																										
1- Blue (A)	+	-	-	+																										
2- Red (B)	+	+	-	-																										
3- White (A)	-	+	+	-																										
4- Yellow (B)	-	-	+	+																										
<p>Standard</p>	<table border="1" style="width: 100%;"> <thead> <tr> <th colspan="2" style="text-align: left;">Damper</th> <th colspan="2"></th> </tr> <tr> <th>Test Points</th> <th>Result</th> <th>Test Points</th> <th>Result</th> </tr> </thead> <tbody> <tr> <td>Red and Yellow</td> <td>373 ~ 456Ω</td> <td>Blue and White</td> <td>373 ~ 456Ω</td> </tr> </tbody> </table>	Damper				Test Points	Result	Test Points	Result	Red and Yellow	373 ~ 456Ω	Blue and White	373 ~ 456Ω																	
Damper																														
Test Points	Result	Test Points	Result																											
Red and Yellow	373 ~ 456Ω	Blue and White	373 ~ 456Ω																											

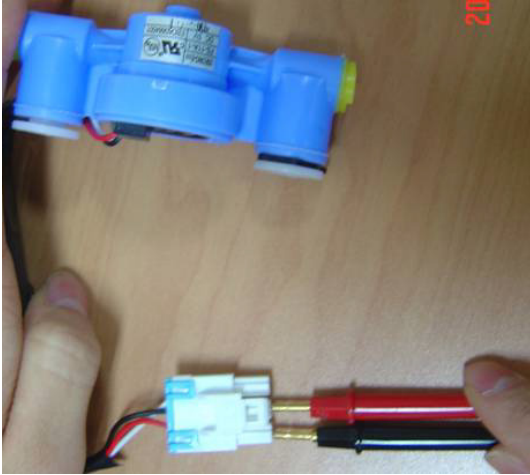
11-9 Flow Sensor

<p>Function</p>	<p>Flow Sensor (in machine room) Count the water quantity from city water to water filter in refrigerator</p>					
<p>How to Measure</p>	 <p style="text-align: center;">Flow Sensor (in machine room)</p>					
<p>Standard</p>	<table border="1" style="margin-left: auto; margin-right: auto;"> <thead> <tr> <th>Test Points</th> <th>Result</th> </tr> </thead> <tbody> <tr> <td>Red wire to Black wire</td> <td>4 ~ 30 kΩ</td> </tr> </tbody> </table>		Test Points	Result	Red wire to Black wire	4 ~ 30 k Ω
Test Points	Result					
Red wire to Black wire	4 ~ 30 k Ω					

Troubleshooting

- COMP Operation Error LED Check



1. Open the PCBA Cover



2. Check the number of LED blinks
(Refer to the next page for resolution by number of LED blinks)



3. When the COMP is normal, it will not blink

When the COMP & FAN are not operating simultaneously, force operate from the Main PCB in TEST MODE to check whether it is operating and then check the power of the COMP end to reset the power.

Troubleshooting

- Simple Check Flow Chart

LED	Trip Information
1	Current/Voltage Sensing Error
2	Over Stroke
3	Comp Connection Error
4	Over Voltage Error
5	Comp Lock Error
6	Over Current Error
7	IPM Error
8	Communication Error

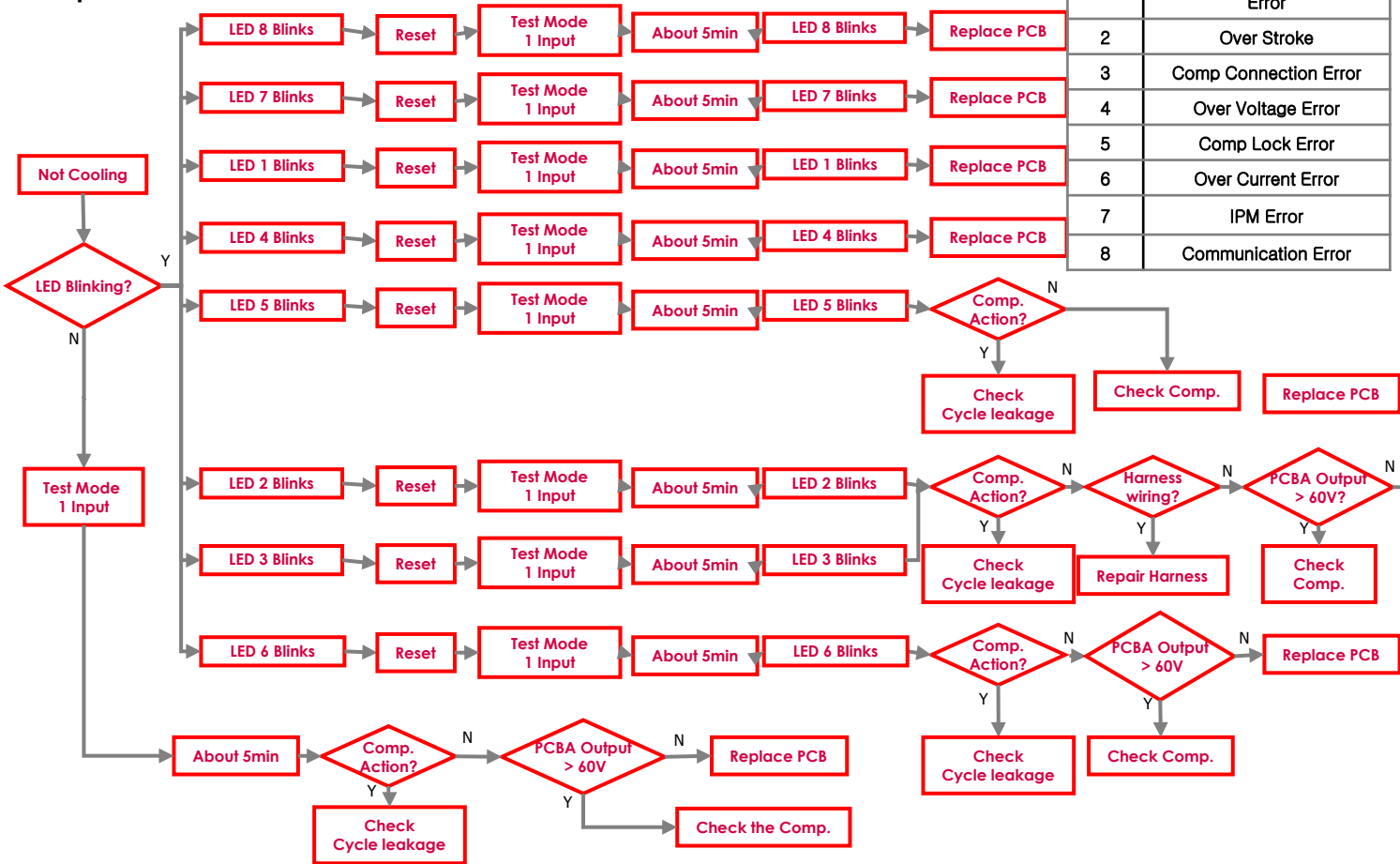

* Transmits LED blinking number to PDA after completing action

What to do per LED Blinking and Trip protection Logic

1. FCT0 Trip and LED Blinking 1 time (FCT0 Fault)



- Purpose : To detect the compressor voltage and current sensing error.
- Restart every 30 seconds after compressor off.



What to do per LED Blinking and Trip protection Logic

2. Stroke Trip and LED Blinking 2 times (Stroke Trip)



- Purpose : Protection piston crash by abnormally large stroke.
- Case 1. Do not operate COMP : Harness connection failure between the PCB, COMP, Capacitor.
- Case 2. Do operate COMP intermittently : Condenser Fan or Freezer Fan Error.
System Error like water-clogging, capillary-clogging, Refrigerant-leakage
- Logic : After the COMP off every 1 minute restart COMP

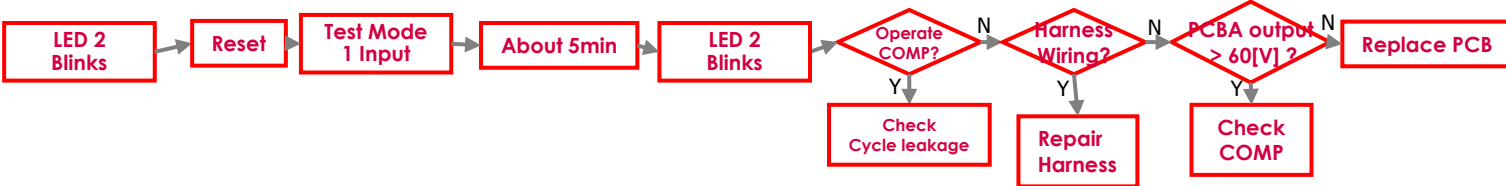

What to do per LED Blinking and Trip protection Logic

3. No Connection Trip And LED Blinking 3 times (No Connect Trip)



- Purpose : Prevention Over-Voltage and Over-Current by detecting connection error check.
- Cause : Harness connection failure between PCB, Comp, Capacitor.
Comp. insulation breakdown.
- Logic : After the Comp. Off every 40 seconds restart Comp.

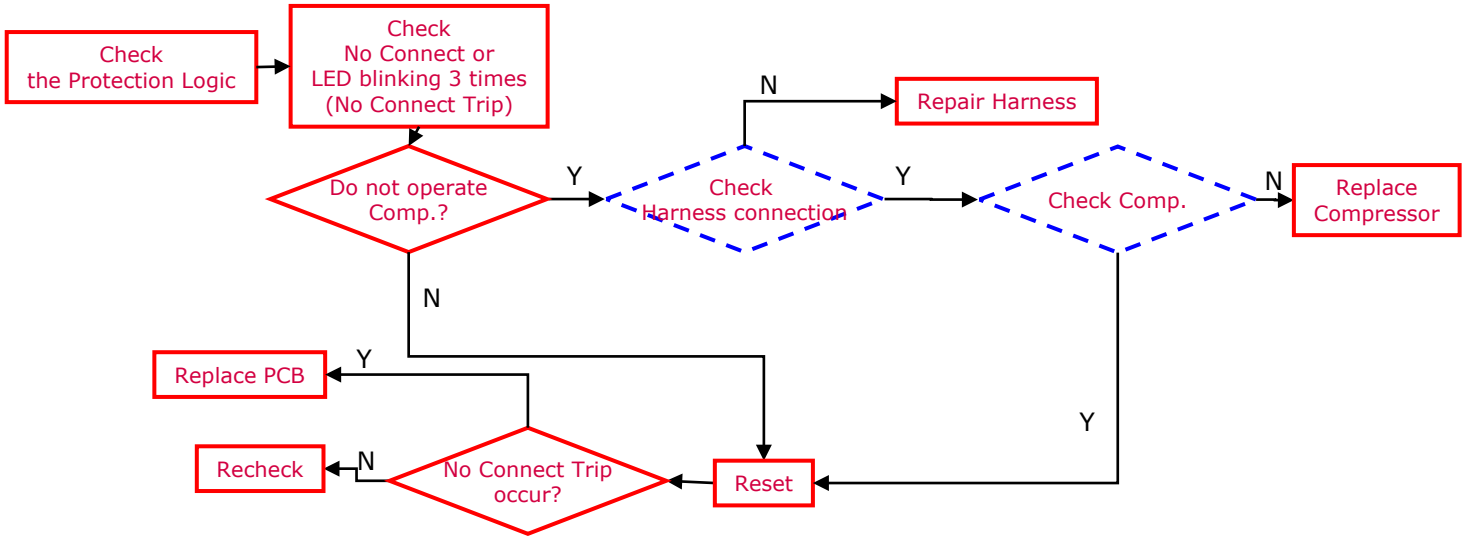

What to do per LED Blinking and Trip protection Logic

4. Over Voltage Trip and LED Blinking 4 times (Over Voltage Trip)



Blink Blink BlinkBlink OFF Blink Blink Blink Blink OFF

- Purpose : Protection the PCB by Over Voltage.
- Cause : DC Link Over Voltage Input(over 450V_{DC})
- Logic : After the Comp. Off every 90 seconds restart Comp.



What to do per LED Blinking and Trip protection Logic

5. Lock Piston Trip and LED Blinking 5 times (Locked Piston)



BlinkBlinkBlinkBlinkBlinkOFF

- Purpose : Detect locked piston.
- Cause : Oil shortage of the cylinder, Cylinder or Piston damage, clogging the discharge, Comp. internal debris.
- Logic : After the Comp. Off every 2 min 30 seconds restart Comp.

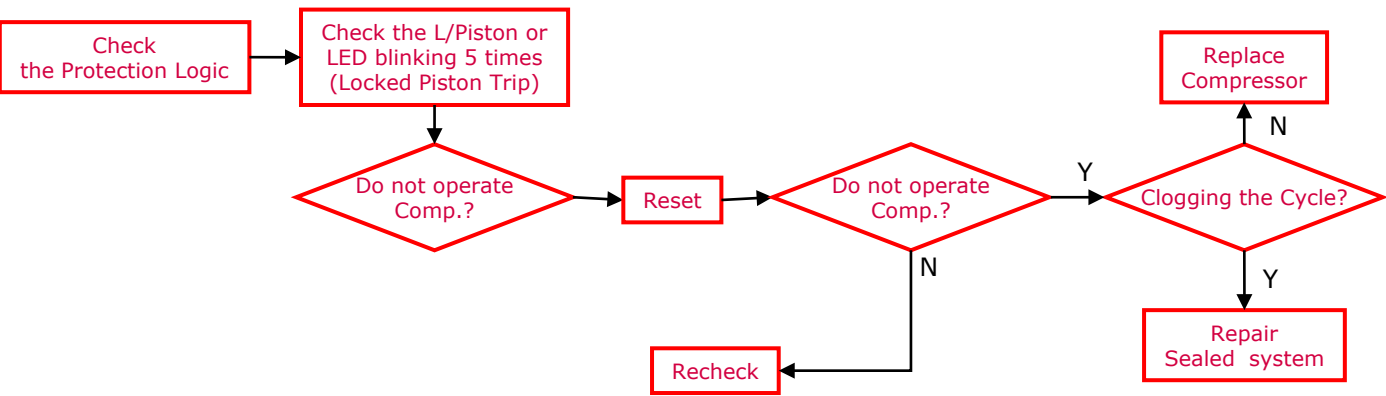

What to do per LED Blinking and Trip protection Logic

6. Current Trip and LED Blinking 6 times (Current Trip)



Blink Blink Blink Blink Blink Blink OF

- Purpose : Protection Over-Current(Over-Load)
- Cause : Abnormally ambient temperature(Over 43°C), Abnormally conditions like Shield machine room etc.
Condenser Fan failure, Comp. failure, PCB failure(IPM breakdown)
Oil shortage of the cylinder, Cylinder or Piston damage, clogging the discharge, Comp. internal debris.
- Logic : After the Comp. Off every 6 minutes restart Comp.

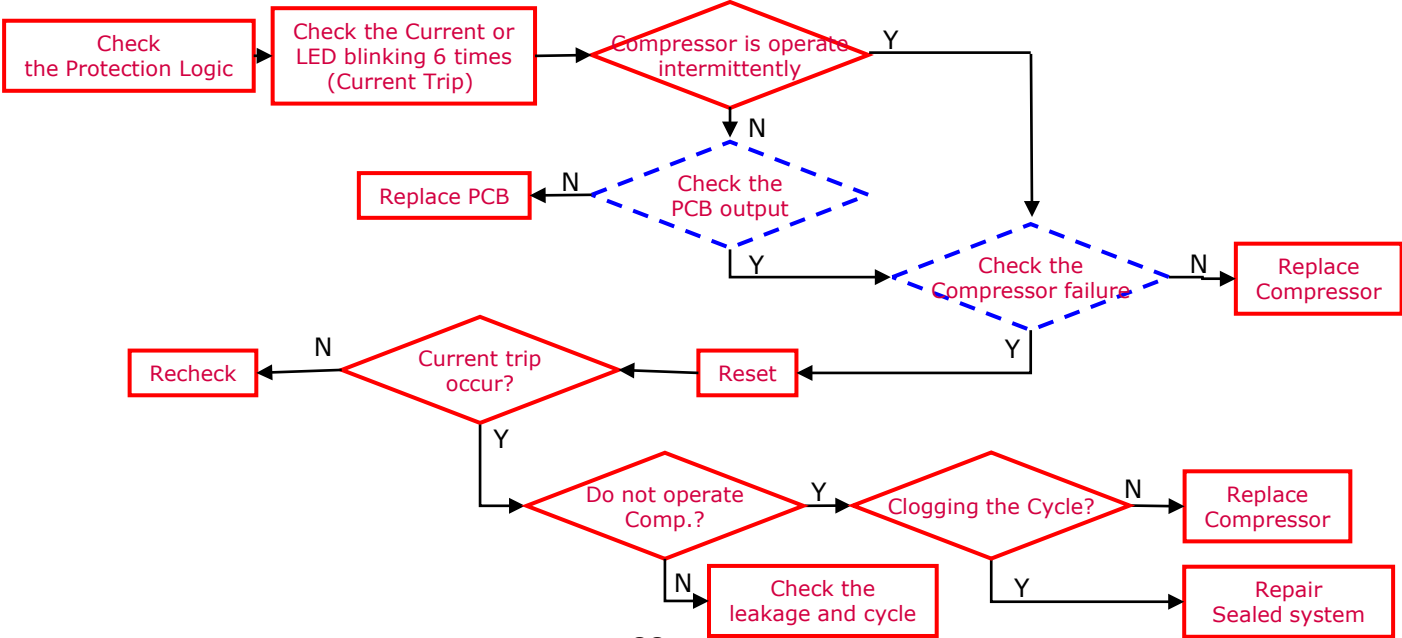

What to do per LED Blinking and Trip protection Logic

7. IPM Fault Trip and LED Blinking 7 times (IPM Fault)



Blink Blink BlinkBlink BlinkBlinkBlink OFF

- Purpose : Protection Over-Current by failure IPM(IPM short)
- Cause : IPM Short and failure
- Logic : After the Comp. Off every 20 seconds restart Comp.



What to do per LED Blinking and Trip protection Logic

8. Comp TX Error Trip and LED Blinking 8 times (Communication Error)



Blink Blink BlinkBlinkBlinkBlinkBlink OFF

- Purpose : Detection communication error with the Micom of the refrigerator control.
- Cause : Communication Error
- Logic : Only LED blinking without the Comp. Off
(Comp. is operate command before communication error)



Check the PCB Output

- Check output voltage from PCB

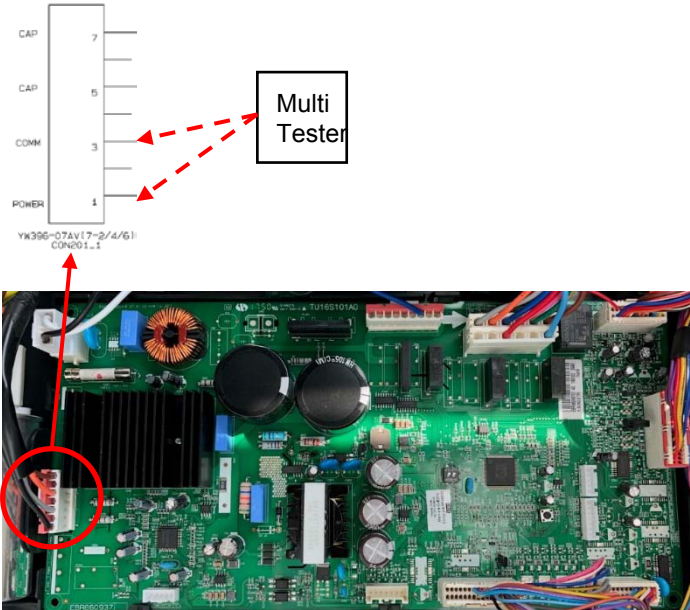

A-Inverter

IPM Output check

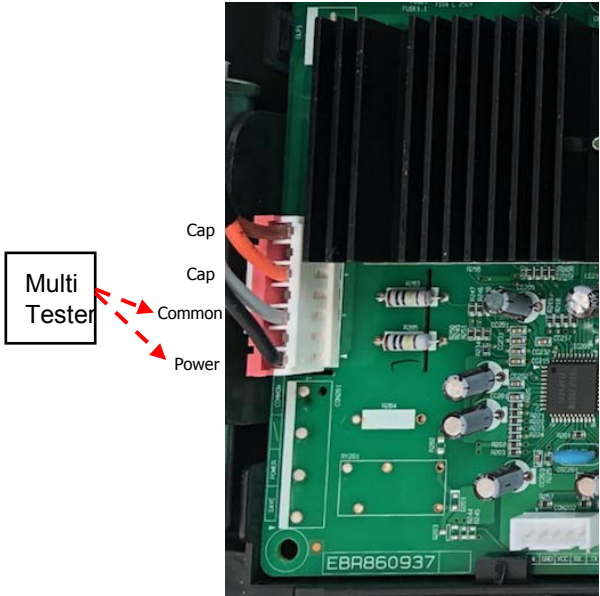

→ To judge whether there is any issue with the PCB operation, check the PCB output voltage.

Normal: Voltage 80[V] or higher output at COMMON - POWER

Check the Compressor & Harness

- 1. Check the Harness connection → Step 1. Power off.
- 2. Check the Compressor
 - Step 2. Check the Resistance(point A)
 - Step 3. Check the Harness(INF ohm).
 - Step 4. Check the Resistance(point B)
 - Step 5. Check the Resistance(point D)

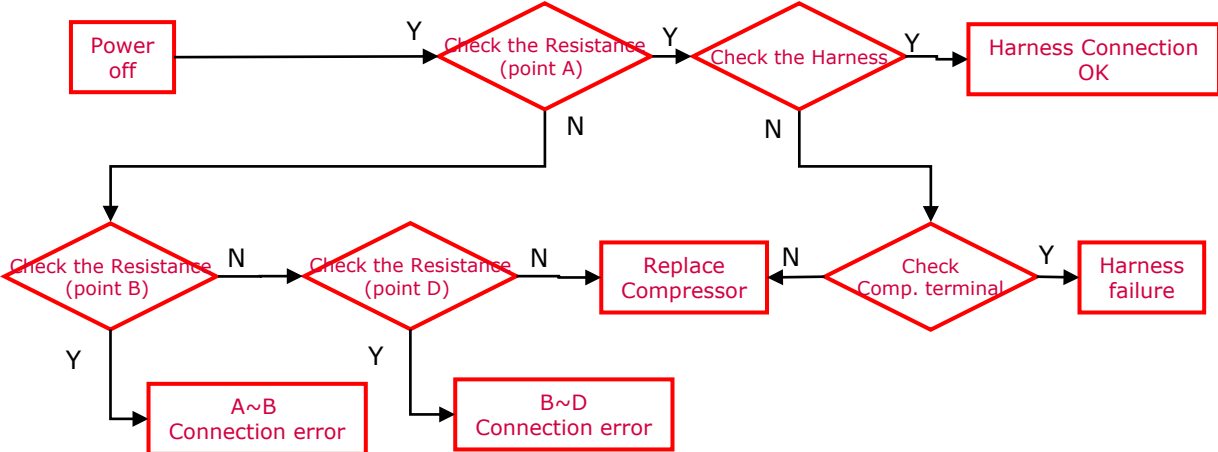

12-5 SERVICE DIAGNOSIS CHART

COMPLAINT	D E K	C E H C E Y B D O E T M
No Cooling.	<ul style="list-style-type: none"> Is the power cord unplugged from the outlet? Check if the power switch is set to OFF. Check if the fuse of the power switch is shorted. Measure the voltage of the power outlet. 	<ul style="list-style-type: none"> Plug into the outlet. Set the switch to ON. Replace the fuse. If the voltage is low, correct the wiring.
Cools poorly.	<ul style="list-style-type: none"> Check if the unit is placed too close to the wall. Check if the unit is placed too close to the stove, gas cooker, or in direct sunlight. Is the ambient temperature too high or the room door closed? Check if food put in the refrigerator is hot. Did you open the door of the unit too often or check if the door is sealed properly? Check if the Control is set to Warm position. 	<ul style="list-style-type: none"> Place the unit about 4 inches (10 cm) from the wall. Place the unit away from these heat sources. Lower the ambient temperature. Put in foods after they have cooled down. Don't open the door too often and close it firmly. Set the control to Recommended position.
Food in the Refrigerator is frozen.	<ul style="list-style-type: none"> Is food placed in the cooling air outlet? Check if the control is set to colder position. Is the ambient temperature below 41°F(5°C)? 	<ul style="list-style-type: none"> Place foods in the high-temperature section. (front part) Set the control to Recommended position. Set the control to Warm position.
Condensation or ice forms inside the unit.	<ul style="list-style-type: none"> Is liquid food sealed? Check if food put in the refrigerator is hot. Did you open the door of the unit too often or check if the door is sealed properly? 	<ul style="list-style-type: none"> Seal liquid foods with wrap. Put in foods after they have cooled down. Don't open the door too often and close it firmly.
Condensation forms in the Exterior Case.	<ul style="list-style-type: none"> Check if the ambient temperature and humidity of the surrounding air are high. Is there a gap in the door gasket? 	<ul style="list-style-type: none"> Wipe moisture with a dry cloth. It will disappear in low temperature and humidity. Fill up the gap.
There is abnormal noise.	<ul style="list-style-type: none"> Is the unit positioned in a firm and even place? Are any unnecessary objects placed in the back side of the unit? Check if the Drip Tray is not firmly fixed. Check if the cover of the compressor enclosure in the lower front side is taken out. 	<ul style="list-style-type: none"> Adjust the Leveling Screw, and position the refrigerator in a firm place. Remove the objects. Fix the Drip Tray firmly in the original position. Place the cover in its original position.
Door does not close well.	<ul style="list-style-type: none"> Check if the door gasket is dirty with an item like juice. Is the refrigerator level? Is there too much food in the refrigerator? 	<ul style="list-style-type: none"> Clean the door gasket. Position in a firm place and level the Leveling Screw. Make sure food stored in shelves does not prevent the door from closing.
Ice and foods smell unpleasant.	<ul style="list-style-type: none"> Check if the inside of the unit is dirty. Are foods with a strong odor unwrapped? The unit smells of plastic. 	<ul style="list-style-type: none"> Clean the inside of the unit. Wrap foods that have a strong odor. New products smell of plastic, but this will go away after 1-2 weeks.

● Other possible problems:

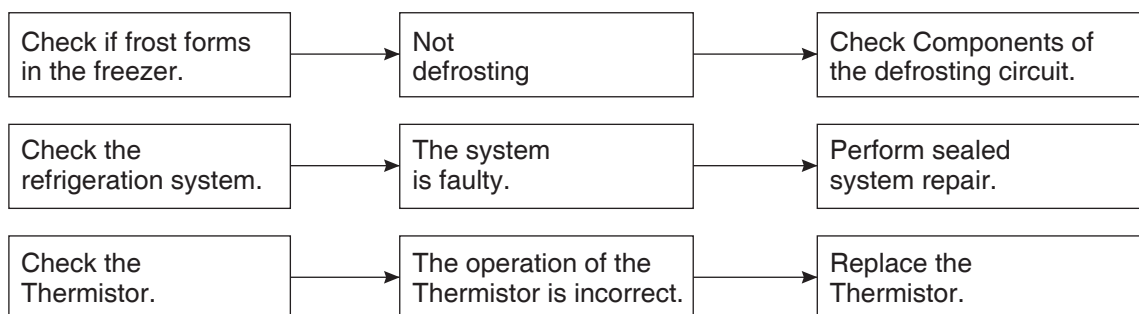

12-6 REFRIGERATION CYCLE

▼ Troubleshooting Chart

CAUSE		STATE OF THE UNIT	STATE OF THE EVAPORATOR	TEMPERATURE OF THE COMPRESSOR	REMARKS
LEAKAGE	PARTIAL LEAKAGE	Freezer compartment and Refrigerator don't cool normally.	Low flowing sound of Refrigerant is heard and frost forms in inlet only.	A little higher than ambient temperature.	<ul style="list-style-type: none"> Refrigerant level is low due to a leak. Normal cooling is possible by restoring the normal amount of refrigerant and repairing the leak.
	COMPLETE LEAKAGE	Freezer compartment and Refrigerator don't cool normally.	Flowing sound of refrigerant is not heard and frost isn't formed.	Equal to ambient temperature.	<ul style="list-style-type: none"> No discharging of Refrigerant. Normal cooling is possible by restoring the normal amount of refrigerant and repairing the leak.
CLOGGED BY DUST	PARTIAL CLOG	Freezer compartment and Refrigerator don't cool normally.	Flowing sound of refrigerant is heard and frost forms in inlet only.	A little higher than ambient temperature.	<ul style="list-style-type: none"> Normal discharging of the refrigerant. The capillary tube is faulty.
	WHOLE CLOG	Freezer compartment and Refrigerator don't cool.	Flowing sound of refrigerant is not heard and frost isn't formed.	Equal to ambient temperature.	<ul style="list-style-type: none"> Normal discharging of the Refrigerant.
MOISTURE CLOG		Cooling operation stops periodically.	Flowing sound of refrigerant is not heard and frost melts.	Lower than ambient temperature.	<ul style="list-style-type: none"> Cooling operation restarts when heating the inlet of the capillary tube.
DEFECTIVE COMPRESSION	COMP-RESSION	Freezer and Refrigerator don't cool.	Low flowing sound of refrigerant is heard and frost forms in inlet only.	A little higher than ambient temperature.	<ul style="list-style-type: none"> Low pressure at high side of compressor due to low refrigerant level.
	NO COMP-RESSION	No compressing operation.	Flowing sound of refrigerant is not heard and there is no frost.	Equal to ambient temperature.	<ul style="list-style-type: none"> No pressure in the high pressure part of the compressor.

12-6-1 Cleaning

There is no need for routine condenser cleaning in normal Home operating environments. If the environment is particularly greasy or dusty, or there is significant pet traffic in the home, the condenser should be cleaned every 2 to 3 months to ensure maximum efficiency.

If you need to clean the condenser:

- Remove the mechanical cover.
- Use a vacuum cleaner with a soft brush to clean the grille, the open areas behind the grille and the front surface area of the condenser.
- Replace the mechanical cover.

12-6-2 SEALED SYSTEM DIAGNOSIS

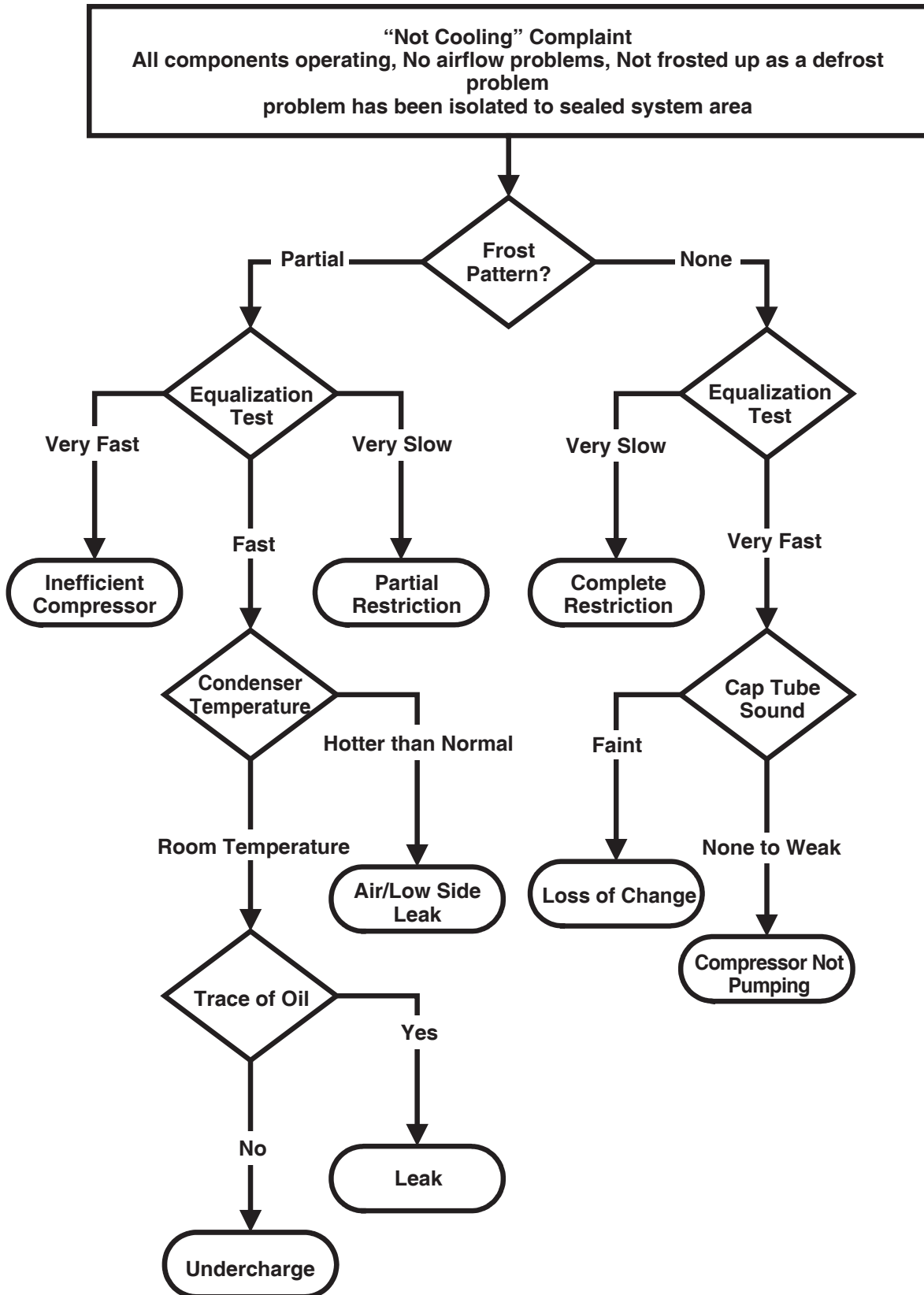

(The equalization test is trying to restart a compressor using a start kit after it has been operating.)

13. ICEMAKER OPERATING METHOD AND TROUBLE SHOOTING

13-1 Icemaker's Basic Operating Method

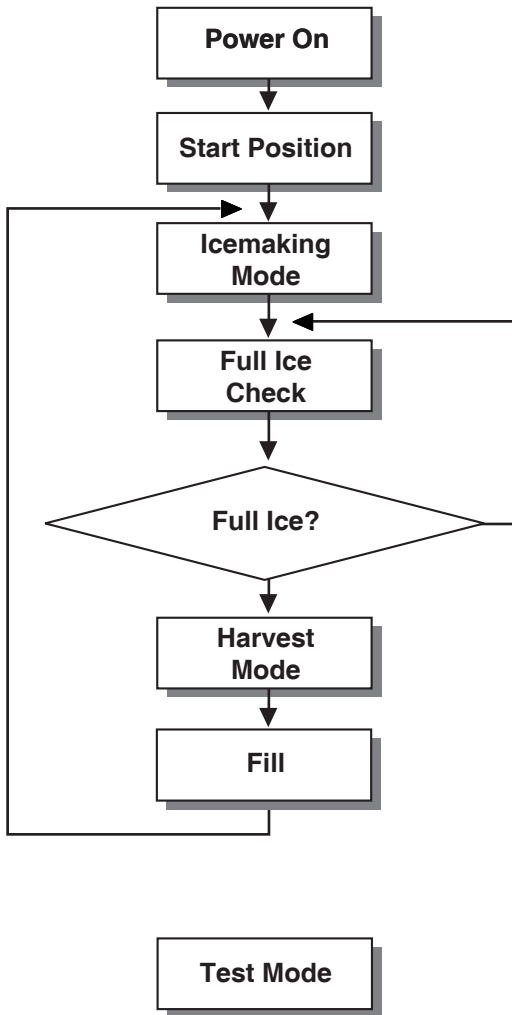

• Adjusts Ice Tray to Start Position with power on.



• Waits until water becomes ice.
 ※For cold air circulation, Ice tray will be on a slightly tilt one hour after ice-making mode begins. A tilt ice tray means icemaker's normal operation.



• If water becomes ices in the ice tray, Ice-detecting sensor check if the ice bin is full.



• Twist the ice tray to drop ice into the ICE BIN.



• Supply water to the ice tray by operating the solenoid valve.



• To force water to supply to the ice tray, or check icemaker's condition press and hold the **FILL Key** for about 3seconds.
 In the test mode, The icemaker will run through 3 stages step by step
 : **Harvest** → **Fill water** → **Ice making**

To reset the icemaker's operation, set the power switch OFF position and back it to ON position.

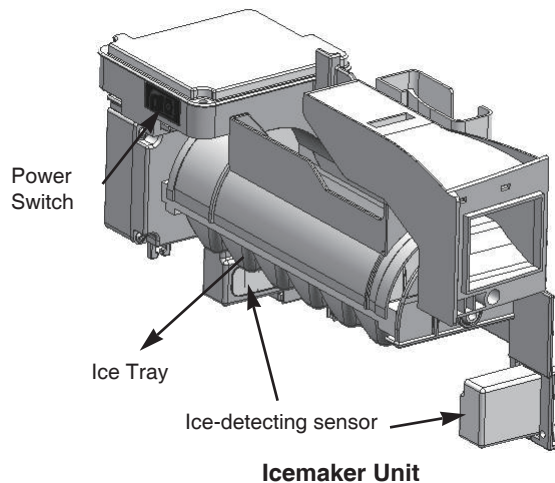

13-2 ICE MAKER FUNCTIONS

13-2-1 Icemaking Mode

1. Icemaking Mode begins right after the ice tray fills with water.
 2. Icemaker waits until water becomes ice in the ice tray.
- ※ Ice-detecting sensor checks if the ice bin is full every 2min.

13-2-2 Harvest Mode

At least in 110min, since icemaker begun icemaking mode, Icemaker starts to twist the ice tray to drop ices into the Ice bin.
(After installation, at least 1day is needed to make ices)

- ※ If the icemaker never drop ices to the ice bin though water becomes ices in the ice tray, check the real temperature of compartment. (not temperature on display)
Icemaker needs below 0°F to drop ices to ice bin.

13-2-3 Fill/Park Position

Once the normal harvest mode has been completed, the water solenoid will be activated.

13-3 Trouble Shooting Ice & Water system Issues

13-3-1 Icemaker not making ice or not making enough ice (Environmental Diagnosis)

- ☒ Icemaker can't make ices itself. Basically, water, temperature and time are needed.
- Water : If no Water, then no Ice.
 - Temperature : The compartment, where the icemaker is located, has to be at least 1°F so that icemaker dumps ices to the bin.
 - Time : At least 80 minutes must be passed to make one series of ices after water comes into icemaker.
- ※ **Test Mode should not be carried out before checking below.**

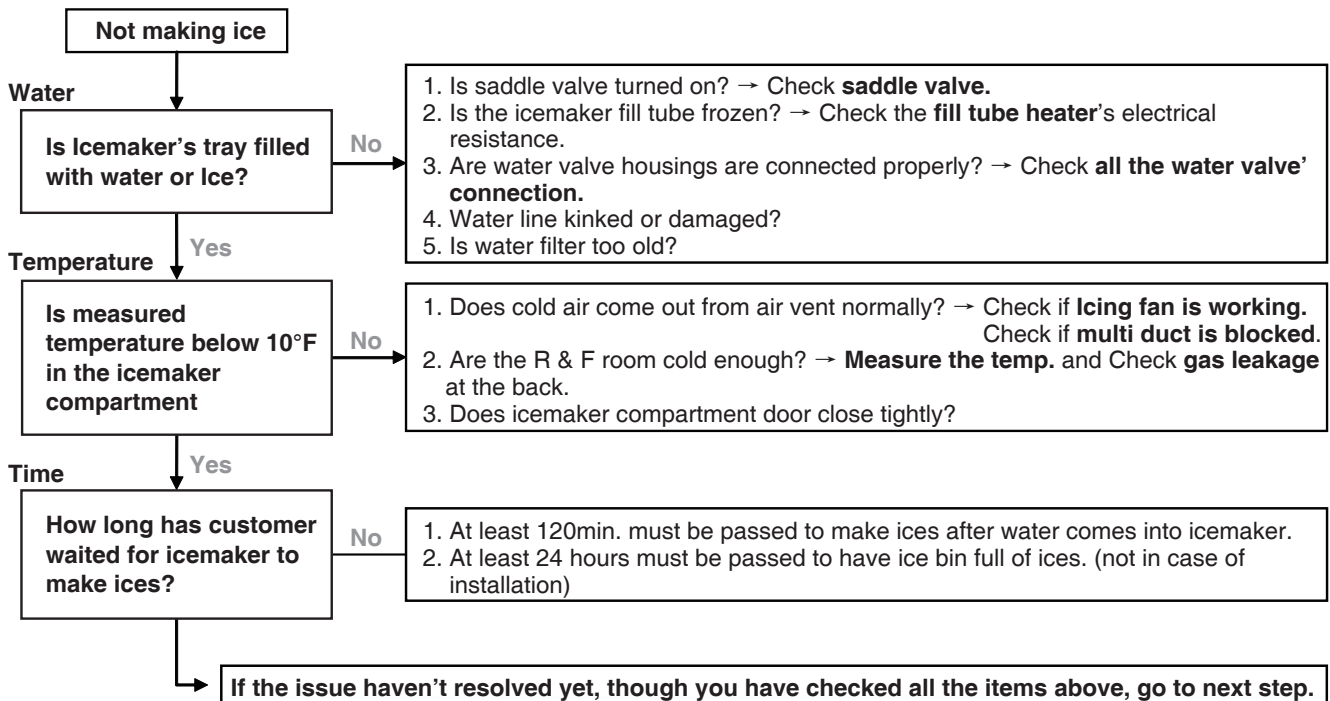

13-3-2 Icemaker not making ice or not making enough ice (Icemaker Unit & Ice-detecting sensor Diagnosis)

☒ Icemaker Unit and Ice-detecting sensor Diagnosis

The icemaker unit and Ice-detecting sensor is programmed to be diagnosed.

Follow the procedure step by step to check to see if icemaker and Ice-detecting sensor is working normally.

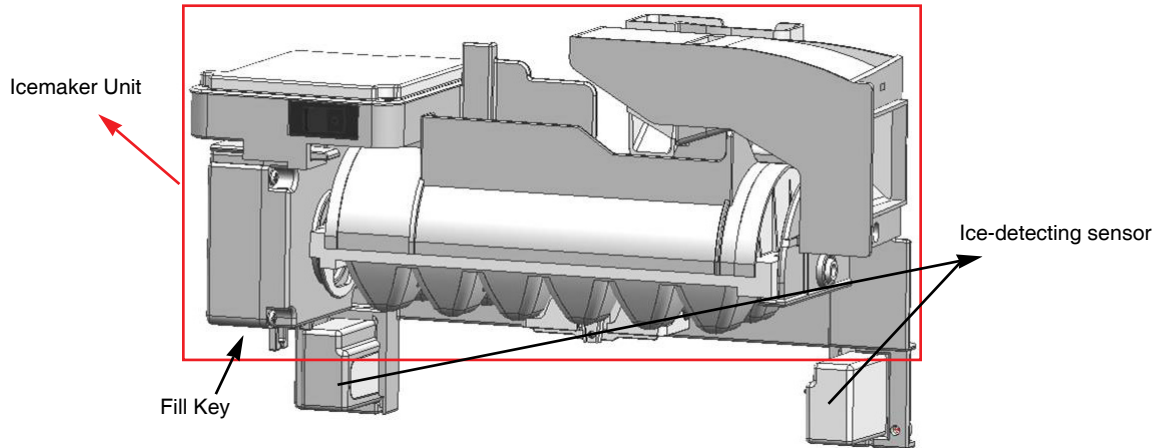

1st STEP (Icemaker Unit Diagnosis)

Press the fill key for about 3sec. If the icemaker runs 2 stages of harvest and filling water step by step, It means icemaker's mechanism is normal.

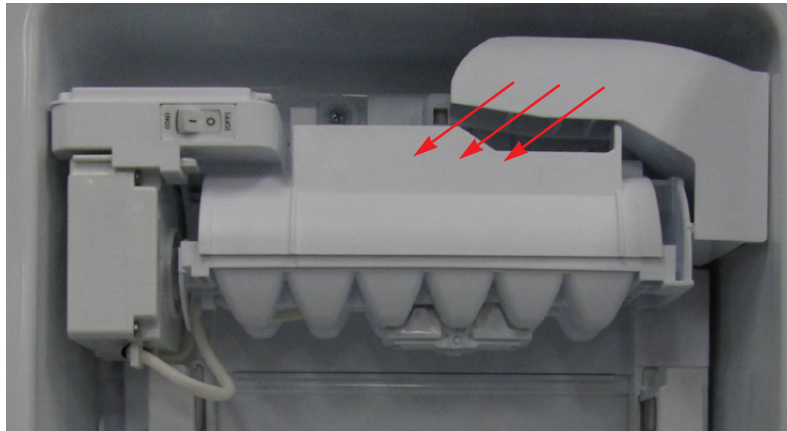

※ Caution : Be sure that the ice tray is not filled with water before pressing fill key.

2st STEP (Ice-detecting sensor Diagnosis)

1. Remove Ice bin from compartment

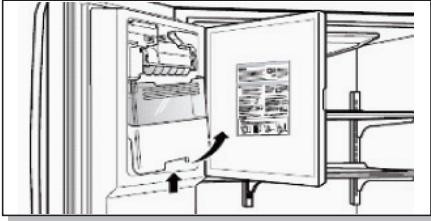

2. Close the left door (Door switch pushed)

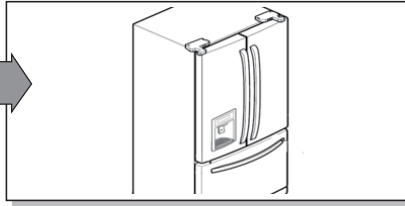

3. Wait for 3min.



4. Freezer door stays open

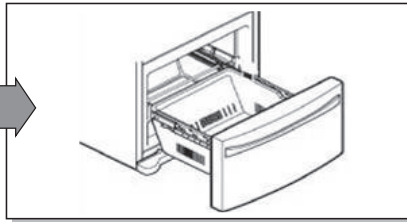

5. Push the refrigerator button & lock button at the same time.

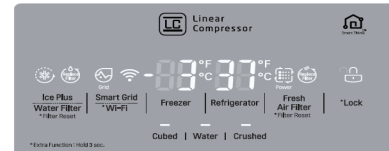

If **"ETY"** is shown on the display after the procedure above, Ice-detecting sensor is **normal**.
If **"FULL"** is shown on the display after the procedure above, Ice-detecting sensor is **abnormal**.
※ ETY = empty

13-3-3 Icemaker not making ice or not making enough ice (Other Suspected Items)

Strongly suspect items below If the issue remains yet, though all the diagnosis for icemaker has been carried out.

- Cap duct bad sealing
- Defective thermal sensor in the icemaker compartment
- Not cold icemaker compartment area (sealed system)

13-3-4 Not Dispensing Ice

☒ Clogged Ice In the Ice Bin (suspected items)

- Customer haven't used ice dispenser over a week.
 - **Resolution** : the ices gets stuck if customer doesn't use ice dispenser.
In this case, empty the ice bin and wait until the new ices are stacked in the ice bin.
- Temperature of icemaker compartment is not cold enough.
 - **Resolution** : Check ice fan, sealed system, cap duct, vent and other items related to temperature.
- Cap duct doesn't seal the air properly.
 - **Resolution** : Possibly, warm air could get into the compartment and make ices get stuck. Replace the cap duct with new one.
- In-door geared motor doesn't work
 - **Resolution** : Change the in-door geared motor and test it.
- The water comes out of fill cup and the water get into the ice bin.
 - **Resolution** : The water pressure from shutoff valve is too high.
Recommend to use regulator to the customer and close the shutoff valve slightly.

☒ Clogged Ices In the Chute (suspected items)

- Cap duct doesn't seal the air properly.
 - **Resolution** : Possibly, warm air could get into the compartment and make ices get stuck. Replace the cap duct with new one.

14. DESCRIPTION OF FUNCTION & CIRCUIT OF MICOM

14-1 FUNCTION

14-1-1 Function

1. When the appliance is plugged in, it is set to 37°F for Refrigerator and 0°F for freezer.
You can adjust the Refrigerator and the Freezer control temperature by pressing the ADJUST button.
2. When the power is initially applied or restored after a power failure, it is set to Control temperature Previously.
3. If you do not press any button after turning on the power, only CRUSH or CUBE Label that has been selected will be turned on and all other LEDs on the display Panel will be turned off within 60 seconds. (Power Save Mode)
4. If you press a button, only CRUSH, CUBE label and Lock icon that has been selected will be turned on and all other LEDs on the display Panel will be turned off within 20 seconds. (Power Save Mode)

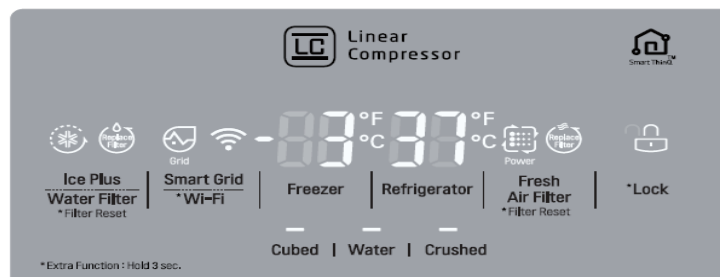

5. If you do not want to use the Power Save Mode, you can change the Mode by pressing the ICE PLUS Button and Freezer TEMP button simultaneously for more than 5 seconds.

14-1-2 How to Toggle the Display between °F & °C

1. The initial setting is °F and the display temperature mode can be changed from °F to °C or °C to °F by pressing and holding the FRZ TEMP and the REF TEMP keys at the same time for over 5 seconds.

14-1-3 Lock function (dispenser and display button lock)

1. When the refrigerator is first turned on, the buttons are not locked. "LOCK" is deactivated with no light on.
2. To lock the display, the dispenser, and the control panel, press and hold the LOCK button for 3 seconds. "LOCK" is activated with "Lock Icon" on.
3. The LOCK button is the only control feature that remains active in the locked state. The buzzer sound, other control buttons, and the dispenser are deactivated.
4. To release from the locked state, press and hold the LOCK button again for 3 seconds.
5. If you don't hold the Alarm/Lock button more than 3 seconds, Alarm function will be changed and alarm for opened door will be on/off same as alarm icon indicating.

14-1-4 Filter condition display function

1. There is a replacement indicator light for the water filter cartridge on the dispenser.
2. Water filter needs replacement once six months or of using water filter.
3. When the Water Filter Icon on, you must exchange the filter.
4. After replacing the filter, press and hold the Water Filter button for more than 3 seconds. After then Water Filter icon turn off with reset status.

Classification

In initial Power On / Filter RESET

Blinking

Filter Status Display



14-1-5 Ice Plus selection

1. Please select ice plus function for quick freezing.
2. When you press the ice plus button, the ice plus icon will be turned on again.
3. Ice plus function automatically turns off after a fixed time passes.
4. If you want additional power save, you can turn on energy saving (some heater off for anti-dew).
5. To turn on or off the energy saving function, press Ice plus/Energy saving Button for more than 3 seconds.
6. We recommend using energy saving function when you go out for quite a long time and are out of the rainy season.

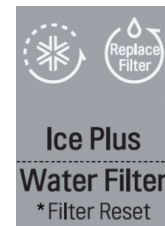

14-1-6 Dispenser use selection

You can select water or ice by separated pad switch.

- When you press ice type button, ice type will be changed. (Crush or Cube)
- Hold your cup in the dispenser for a few seconds after dispensing ice or water to allow the last pieces of ice drops of water to fall into the cup.
- When after initially establishing the water comes out, the water tank inside fills and until at the time of quality the hour is caught.



14-1-7. How to operate the Hygiene fresh filter

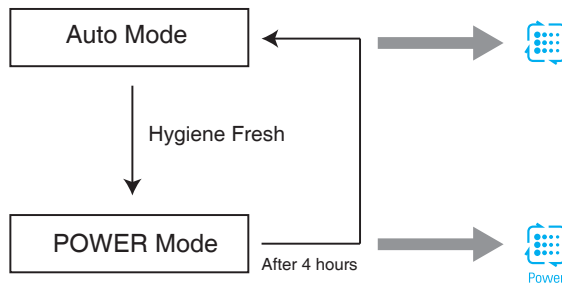
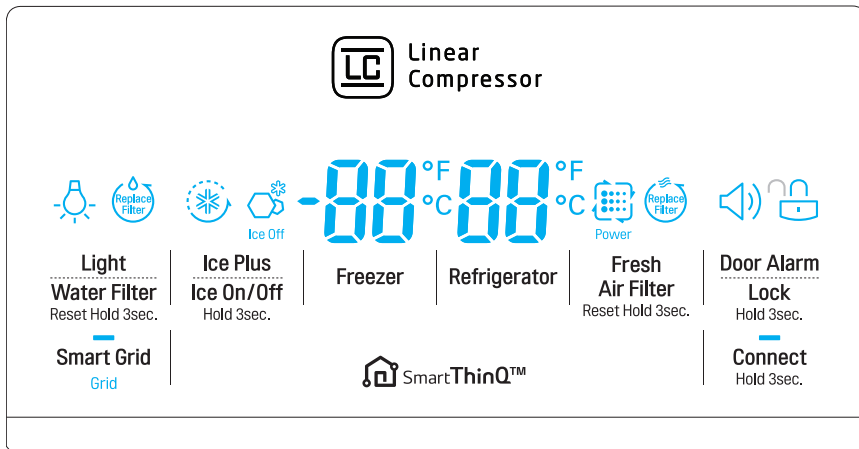

14-1-8. AUTO Mode

1. Fan installed on the multi.duct on the rear side of the filter operates.
2. Fan is repeatedly turned on for 10 minutes and then off for 60 minutes.
3. If the R-door is opened while the fan is operating,the fan will be turned off,and when the R-door is closed,the fan will be turned on.
4. LED near the filter installed on the multi duct is turned on when the R -door is opened and off when closed.

14-1-9. POWER Mode

1. Fan installed on the multi.duct on the rear side of the filter operates.
2. Fan is repeatedly turned on for 10 minutes and then off for 5 minutes for 4 hours,and then automatically switches over to AUTO Mode.
3. If the R -door is opened while the fan is operating,the fan will be turned off,and when the R -door is closed,the fan will be turned on.
4. LED near the filter installed on the multi duct is turned on when the R -d oor is opened and off when closed.

14-1-10 CONTROL OF FREEZER FAN MOTOR

1. Freezer fan motor has high and standard speeds.
2. High speed is used at power-up, for Ultra Ice, and when refrigerator is overloaded.
Standard speeds is used for general purposes.
3. To improve cooling speed, the RPM of the freezer fan motor change from normal speed to high.
4. High speed (2700RPM) : Initial power on or load corresponding operation, Ultra Ice.
Normal speed (2400RPM) : General working conditions.

14-1-11 Cooling Fan Motor

1. The cooling fan is switched ON and OFF in conjunction with the compressor.
2. The cooling fan Motor has high and standard speeds. (When room temperature more high than 38°C speed is high)
3. The Failure sensing method is the same as in the fan motor of the freezing fan motor(refer to failure diagnosis function table for failure display).

14-1-12 Ice Compartment Fan

1. The Icing Fan is controlled by the the sensor on the top of the ice compartment.
2. The Failure sensing method is the same as in the fan motor of the freezer
(refer to failure diagnosis function table for failure display)

14-1-13 Ice PLUS

1. The purpose of this function is to intensify the cooling speed of freezer and to increase the amount of ice.
2. Whenever selection switch is pressed, selection/release, the Icon will turn ON or OFF.
3. If there is a power outage and the refrigerator is powered on again, Ice PLUS will be canceled.
4. To activate this function, press the Ice PLUS key and the Icon will turn ON. This function will remain activated for 24 hrs. The first one hour the compressor, Freezer Fan and Icing Fan will be ON. The next 23 hours the Ice room will be controlled at the lowest temperature. After 24 hours or if the Ice PLUS key is pressed again, the Ice room will return to its previous temperature.
5. During the first hour :
 - (1) Compressor, Freezer Fan and Icing Fan run continuously.
 - (2) If a defrost cycle begins during the first 30 minutes of Ice Plus, the Ice PLUS cycle will complete its cycle after defrosting has ended.
If the defrost cycle begins when Ice Plus has run for more than 30 minutes, Ice PLUS will run for 40 minutes after the defrost is completed.
 - (3) If Ice PLUS is pressed during defrost, Ice Plus Icon is on but this function will start seven minutes after defrost is completed and it shall operate for three hours.
 - (4) If Ice Plus is selected within seven minutes after compressor has stopped, the compressor (compressor delays seven minutes) shall start after the balance of the delay time.
6. For the rest of the 23 hours, the Ice room will be controlled at the lowest temperature.

14-1-14 How to set the display mode and cancel it

1. With the refrigerator door open, keep pressing the Refrigerator Temp Button and ICE PLUS Button more than 5 seconds, then it goes to the display mode with Special Beep Sound With Special Beep Sound.
2. Perform the same way again to cancel the display mode.
3. All Freezing unit will be turned off at display mode (Exceptions : Lamp, Display)

14-1-15 Defrosting (removing frost)

1. Defrosting starts each time the COMPRESSOR running time Between 7~50 hours.
2. For initial power on or for restoring power, defrosting starts when the compressor running time reaches 4 hours.
3. Defrosting stops if the sensor temperature reaches 46.4°F(8°C) or more. If the sensor doesn't reach 46.4°F(8°C) in 1 hours, the defrost mode is malfunctioning. (Refer to the defect diagnosis function, 8-1-15.)
4. Defrosting won't function if its sensor is defective (wires are cut or short circuited)

14-1-16 Defect Diagnosis Function

1. Automatic diagnosis makes servicing the refrigerator easy.
2. When a defect occurs, the buttons will not operate; but the tones. such as ding. will sound.
3. When the defect CODE removes the sign, it returns to normal operation (RESET).
4. The defect CODE shows on the Refrigerator and Freezer Display.

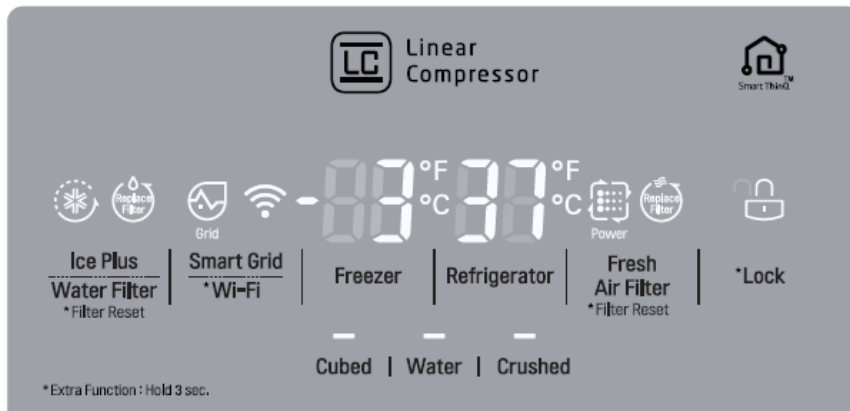

- * Display check function: If simultaneously pressing Ultra Ice button and freezing temperature adjustment button for a second, display LCD graphics on. If releasing the button, the LCD graphic displays the previous status.
You can check the error code Within 3-hour Period from initial error

14-1-17 Auto pantry

1. The temperature control will automatically start upon the selected Auto Pantry temperature control.
2. You can adjust the Pantry control with three different temperature ranges by pressing the Temp.Selector button.

EXPLODED VIEW & REPLACEMENT PARTS LIST

CASE PARTS

CAUTION: Use the part number to order part, not the position number.

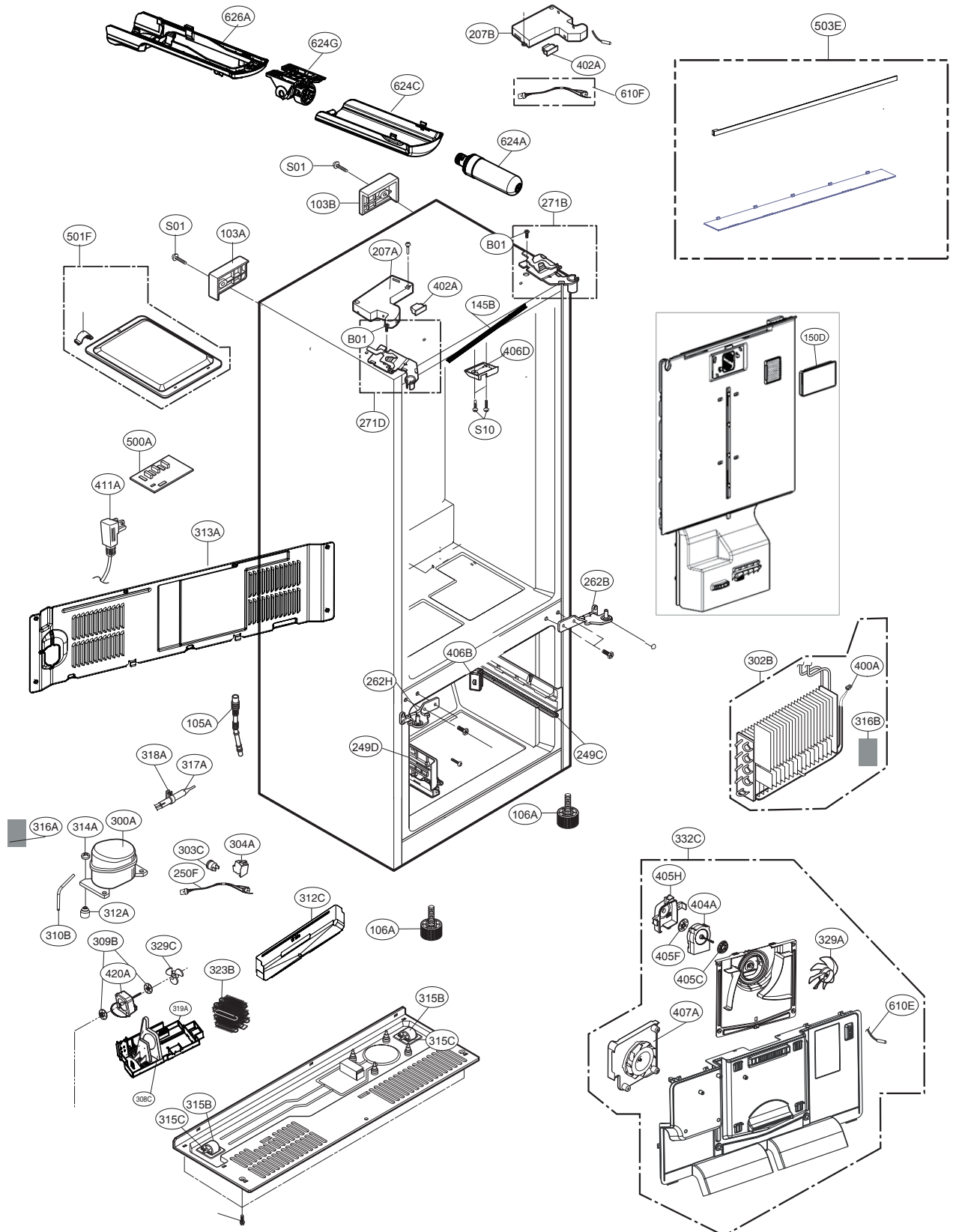

FREEZER PARTS

CAUTION: Use the part number to order part, not the position number.

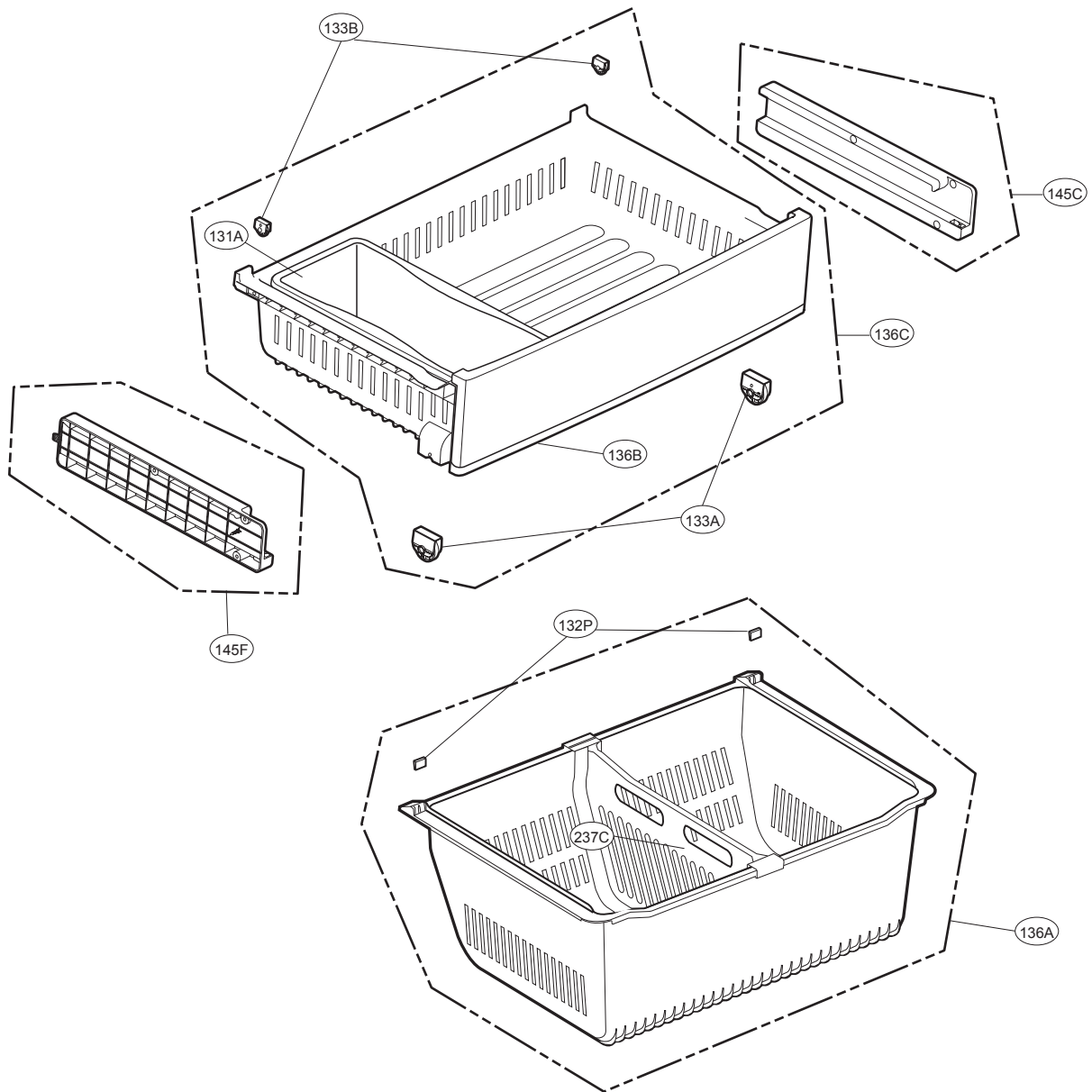

REFRIGERATOR PARTS

CAUTION: Use the part number to order part, not the position number.

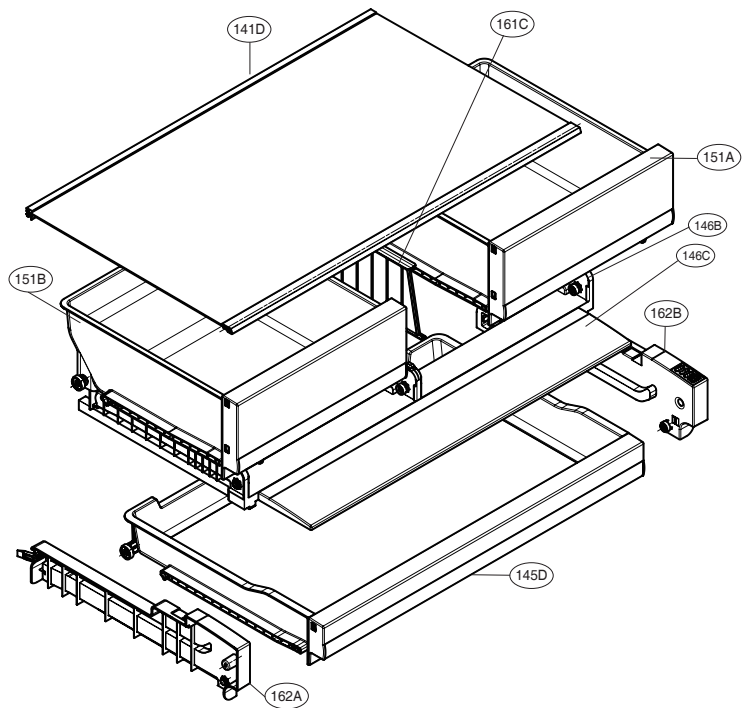
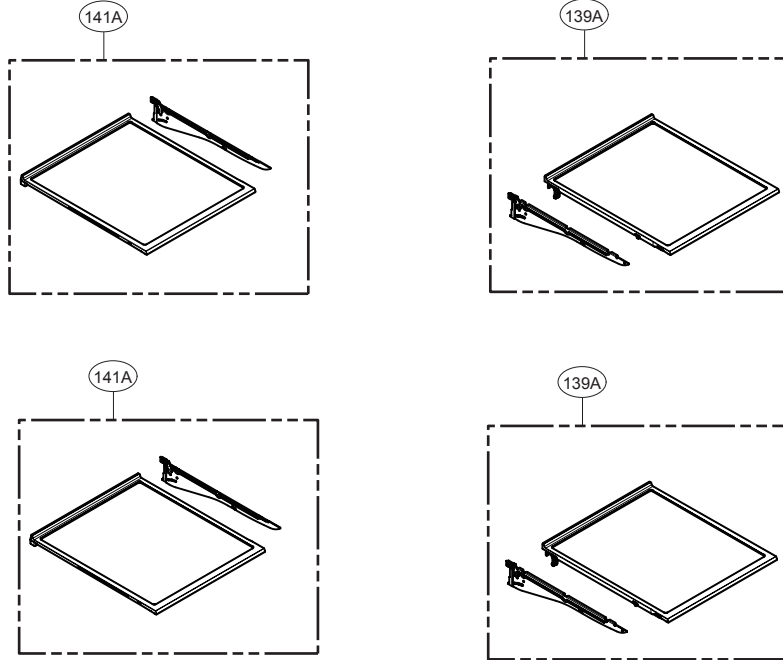

DOOR PARTS

CAUTION: Use the part number to order part, not the position number.

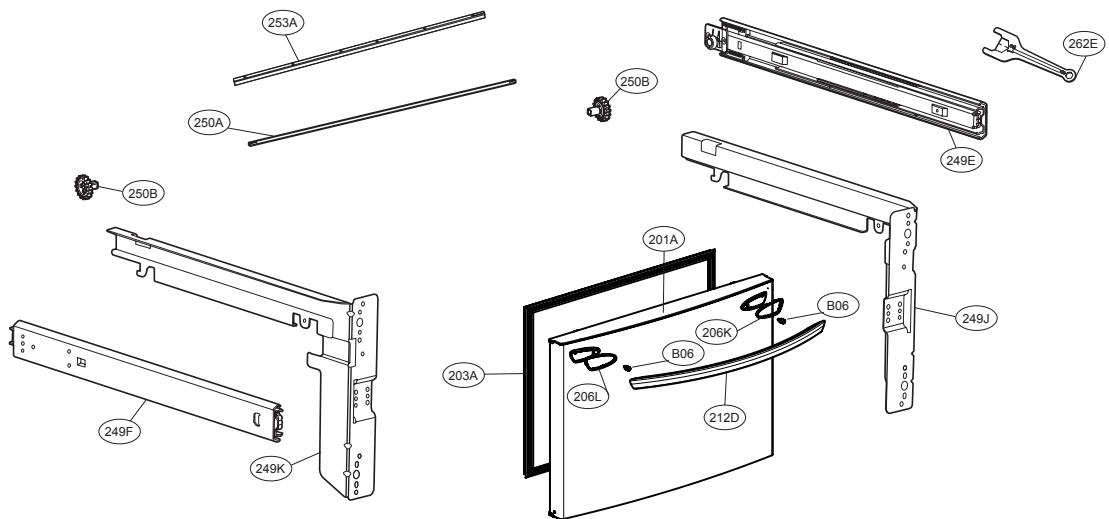
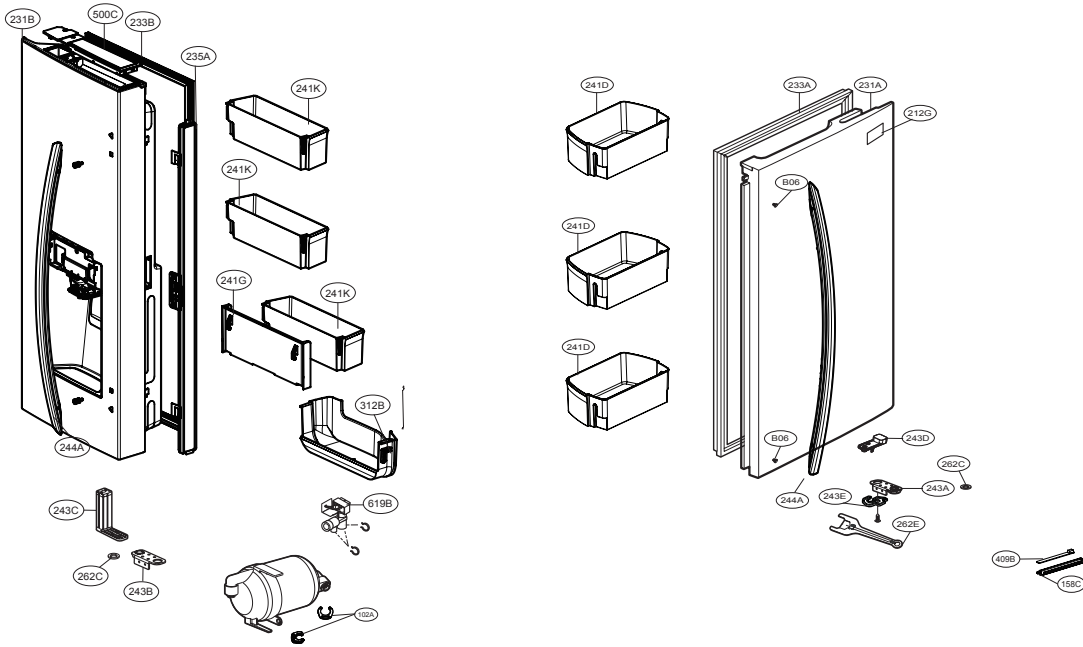

DISPENSER PARTS

CAUTION: Use the part number to order part, not the position number.

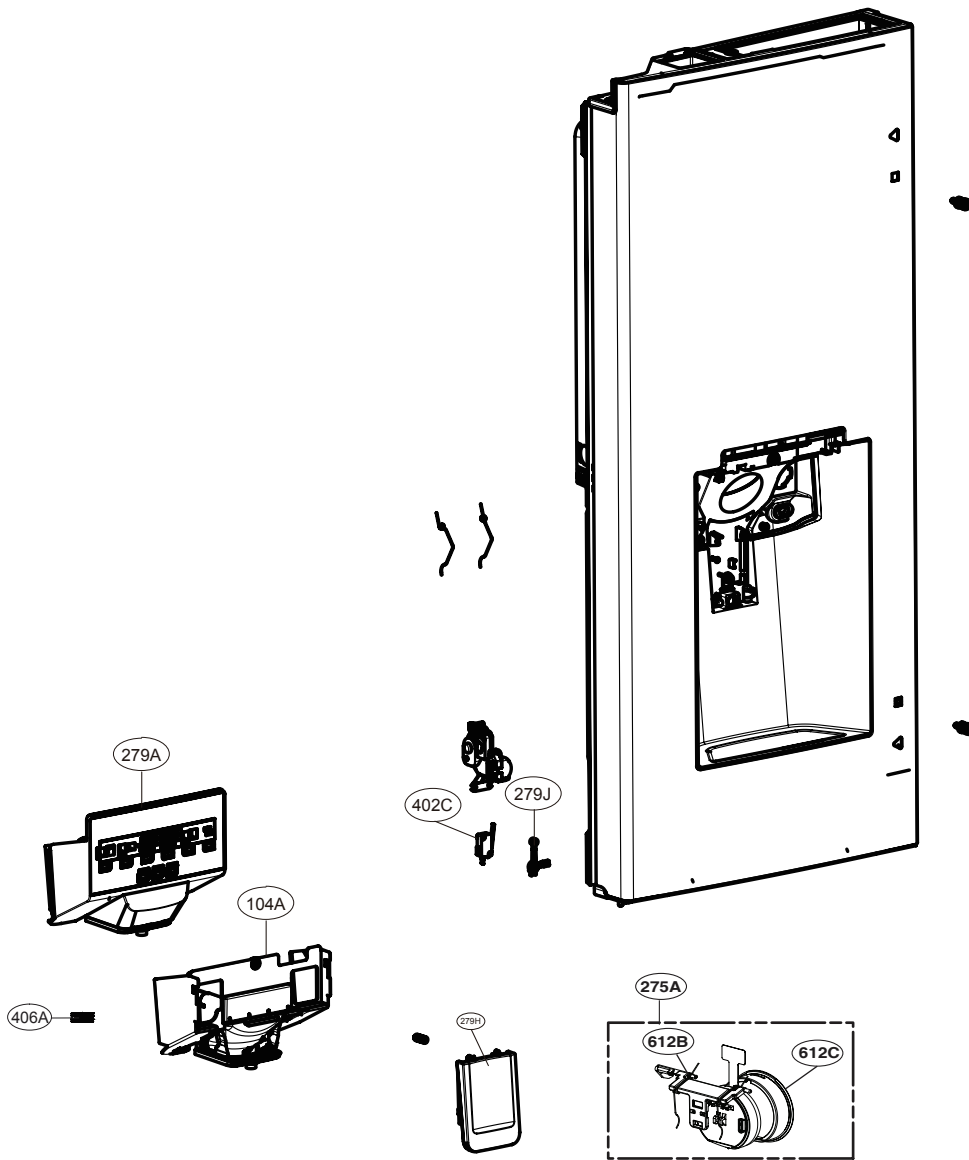

VALVE & WATER TUBE PARTS

CAUTION Use the part number to order part, not the position.

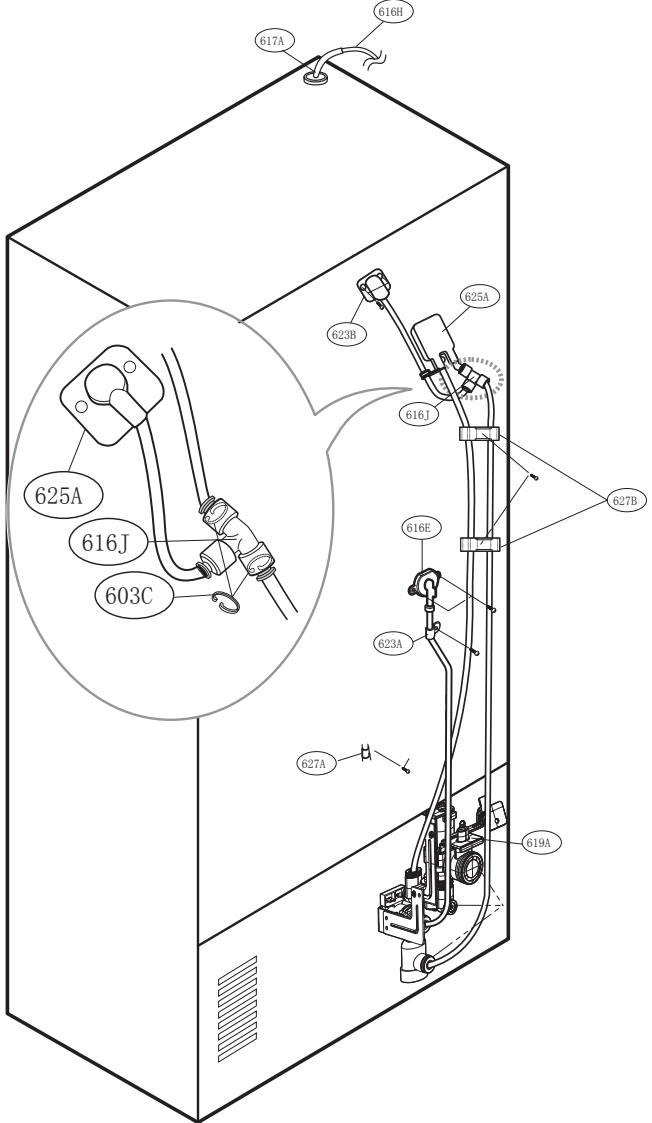
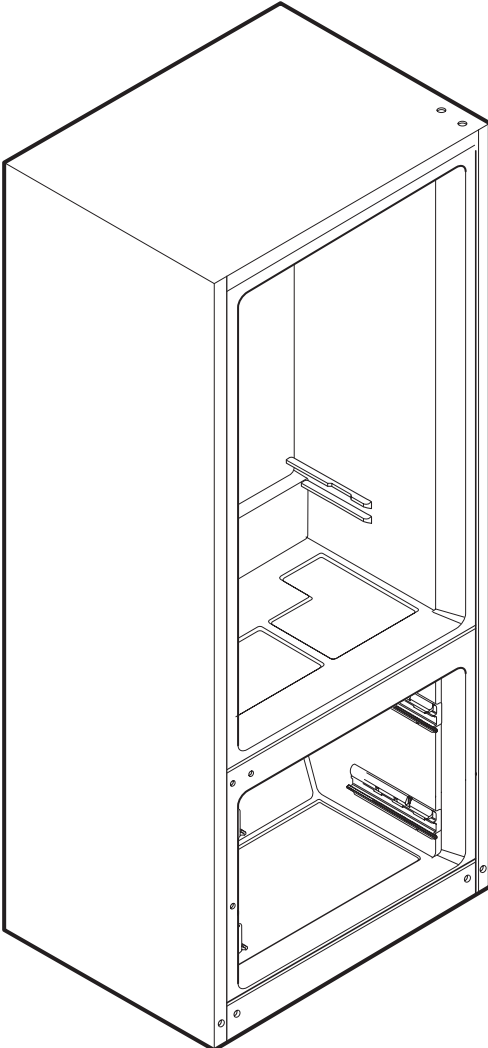



Apr. 2018 Printed in China