



# LG

Life's Good

# LG Digital Signage **SERVICE MANUAL**

**CHASSIS : UW92J**

**MODEL : 50UL3G 50UL3G-BJ**

## **CAUTION**

BEFORE SERVICING THE CHASSIS, READ THE SAFETY PRECAUTIONS IN THIS MANUAL.



P/NO : MFL71500378 (2006-REV00)

Any reproduction, duplication, distribution (including by way of email, facsimile or other electronic means), publication, modification, copying or transmission of this Service Manual is **STRICTLY PROHIBITED** unless you have obtained the prior written consent of the LG Electronics entity from which you received this Service Manual. The material covered by this prohibition includes, without limitation, any text, graphics or logos in this Service Manual.

# CONTENTS

<b>CONTENTS .....</b>	<b>2</b>
<b>PRECAUTION.....</b>	<b>3</b>
<b>SERVICING PRECAUTIONS.....</b>	<b>5</b>
<b>SPECIFICATION .....</b>	<b>7</b>
<b>SOFTWARE UPDATE.....</b>	<b>11</b>
<b>BLOCK DIAGRAM.....</b>	<b>12</b>
<b>EXPLODED VIEW .....</b>	<b>13</b>
<b>TROUBLE SHOOTING GUIDE .....</b>	<b>APPENDIX</b>

# PRECAUTION

## WARNING FOR THE SAFETY-RELATED COMPONENT.

- There are some special components used in LCD monitor that are important for safety. **These parts are marked  $\triangle$  on the Exploded View.** It is essential that these critical parts should be replaced with the manufacturer's specified parts to prevent electric shock, fire or other hazard.
- Do not modify original design without obtaining written permission from manufacturer or you will void the original parts and labor guarantee.

## TAKE CARE DURING HANDLING THE LCD MODULE WITH BACKLIGHT UNIT.

- Must mount the module using mounting holes arranged in four corners.
- Do not press on the panel, edge of the frame strongly or electric shock as this will result in damage to the screen.
- Do not scratch or press on the panel with any sharp objects, such as pencil or pen as this may result in damage to the panel.
- Protect the module from the ESD as it may damage the electronic circuit (C-MOS).
- Make certain that treatment person's body are grounded through wrist band.
- Do not leave the module in high temperature and in areas of high humidity for a long time.
- The module not be exposed to the direct sunlight.
- Avoid contact with water as it may a short circuit within the module.
- If the surface of panel become dirty, please wipe it off with a soft material. (Cleaning with a dirty or rough cloth may damage the panel.)

### $\triangle$ CAUTION

Please use only a plastic screwdriver to protect yourself from shock hazard during service operation.

## $\triangle$ WARNING

BE CAREFUL ELECTRIC SHOCK !

- If you want to replace with the new backlight or inverter circuit, must disconnect the AC adapter because high voltage appears at inverter circuit about 650Vrms.
- Handle with care wires or connectors of the inverter circuit. If the wires are pressed cause short and may burn or take fire.

## Leakage Current Hot Check Circuit

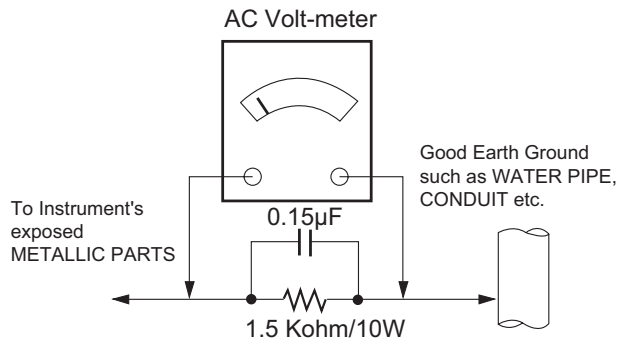

When 25A is impressed between Earth and 2nd Ground for 1 second, Resistance must be less than 0.1

\*Base on Adjustment standard

• **Replaceable batteries**

**⚠ CAUTION**

RISK OF EXPLOSION IF BATTERY IS REPLACED BY AN INCORRECT TYPE.

DISPOSE OF USED BATTERIES ACCORDING TO THE INSTRUCTIONS.

REPLACE ONLY WITH THE SAME OR EQUIVALENT TYPE.

**ADVARSEL**

Lithiumbatteri - Eksplosionsfare ved fejlagtig håndtering.

Udskiftning må kun ske med batteri af samme fabrikat og type.

Levér det brugte batteri tilbage til leverandøren.

**ATTENTION**

Il y a danger d'explosion s'il y a remplacement incorrect de la batterie.

Remplacer uniquement avec une batterie du même type ou d'un type équivalent recommandé par le constructeur.

Mettre au rebut les batteries usagées conformément aux instructions du fabricant.

**VORSICHT**

Explosionsgefahr bei unsachgemäßem Austausch der Batterie

Entsorgung gebrauchter Batterien nach Anleitung

**注意**

**電池を誤って交換すると爆発する危険があります。**

**必ず同一又は同等のタイプのものと交換して下さい。**

# SERVICING PRECAUTIONS

**CAUTION:** Before servicing receivers covered by this service manual and its supplements and addenda, read and follow the SAFETY PRECAUTIONS on page 3 of this publication.

**NOTE:** If unforeseen circumstances create conflict between the following servicing precautions and any of the safety precautions on page 3 of this publication, always follow the safety precautions. Remember: Safety First.

## General Servicing Precautions

1. Always unplug the receiver AC power cord from the AC power source before;
  - a. Removing or reinstalling any component, circuit board module or any other receiver assembly.
  - b. Disconnecting or reconnecting any receiver electrical plug or other electrical connection.
  - c. Connecting a test substitute in parallel with an electrolytic capacitor in the receiver.  
**CAUTION:** A wrong part substitution or incorrect polarity installation of electrolytic capacitors may result in an explosion hazard.
2. Test high voltage only by measuring it with an appropriate high voltage meter or other voltage measuring device (DVM, FETVOM, etc) equipped with a suitable high voltage probe. Do not test high voltage by "drawing an arc".
3. Do not spray chemicals on or near this receiver or any of its assemblies.
4. Unless specified otherwise in this service manual, clean electrical contacts only by applying the following mixture to the contacts with a pipe cleaner, cotton-tipped stick or comparable non-abrasive applicator; 10% (by volume) Acetone and 90% (by volume) isopropyl alcohol (90%-99% strength)  
**CAUTION:** This is a flammable mixture.  
Unless specified otherwise in this service manual, lubrication of contacts is not required.
5. Do not defeat any plug/socket B+ voltage interlocks with which receivers covered by this service manual might be equipped.
6. Do not apply AC power to this instrument and/or any of its electrical assemblies unless all solid-state device heat sinks are correctly installed.
7. Always connect the test receiver ground lead to the receiver chassis ground before connecting the test receiver positive lead.  
Always remove the test receiver ground lead last.
8. Use with this receiver only the test fixtures specified in this service manual.  
**CAUTION:** Do not connect the test fixture ground strap to any heat sink in this receiver.

## Electrostatically Sensitive (ES) Devices

Some semiconductor (solid-state) devices can be damaged easily by static electricity. Such components commonly are called Electrostatically Sensitive (ES) Devices. Examples of typical ES devices are integrated circuits and some field-effect transistors and semiconductor "chip" components. The following techniques should be used to help reduce the incidence of component damage caused by static by static electricity.

1. Immediately before handling any semiconductor component or semiconductor-equipped assembly, drain off any electrostatic charge on your body by touching a known earth ground. Alternatively, obtain and wear a commercially available discharging wrist strap device, which should be removed to prevent potential shock reasons prior to applying power to the

unit under test.

2. After removing an electrical assembly equipped with ES devices, place the assembly on a conductive surface such as aluminum foil, to prevent electrostatic charge buildup or exposure of the assembly.
3. Use only a grounded-tip soldering iron to solder or unsolder ES devices.
4. Use only an anti-static type solder removal device. Some solder removal devices not classified as "anti-static" can generate electrical charges sufficient to damage ES devices.
5. Do not use freon-propelled chemicals. These can generate electrical charges sufficient to damage ES devices.
6. Do not remove a replacement ES device from its protective package until immediately before you are ready to install it. (Most replacement ES devices are packaged with leads electrically shorted together by conductive foam, aluminum foil or comparable conductive material).
7. Immediately before removing the protective material from the leads of a replacement ES device, touch the protective material to the chassis or circuit assembly into which the device will be installed.  
**CAUTION:** Be sure no power is applied to the chassis or circuit, and observe all other safety precautions.
8. Minimize bodily motions when handling unpackaged replacement ES devices. (Otherwise harmless motion such as the brushing together of your clothes fabric or the lifting of your foot from a carpeted floor can generate static electricity sufficient to damage an ES device.)

## General Soldering Guidelines

1. Use a grounded-tip, low-wattage soldering iron and appropriate tip size and shape that will maintain tip temperature within the range or 500 °F to 600 °F.
2. Use an appropriate gauge of RMA resin-core solder composed of 60 parts tin/40 parts lead.
3. Keep the soldering iron tip clean and well tinned.
4. Thoroughly clean the surfaces to be soldered. Use a mall wire-bristle (0.5 inch, or 1.25cm) brush with a metal handle. Do not use freon-propelled spray-on cleaners.
5. Use the following unsoldering technique
  - a. Allow the soldering iron tip to reach normal temperature. (500 °F to 600 °F)
  - b. Heat the component lead until the solder melts.
  - c. Quickly draw the melted solder with an anti-static, suction-type solder removal device or with solder braid.  
**CAUTION:** Work quickly to avoid overheating the circuit board printed foil.
6. Use the following soldering technique.
  - a. Allow the soldering iron tip to reach a normal temperature (500 °F to 600 °F)
  - b. First, hold the soldering iron tip and solder the strand against the component lead until the solder melts.
  - c. Quickly move the soldering iron tip to the junction of the component lead and the printed circuit foil, and hold it there only until the solder flows onto and around both the component lead and the foil.  
**CAUTION:** Work quickly to avoid overheating the circuit board printed foil.
  - d. Closely inspect the solder area and remove any excess or splashed solder with a small wire-bristle brush.

### IC Remove/Replacement

Some chassis circuit boards have slotted holes (oblong) through which the IC leads are inserted and then bent flat against the circuit foil. When holes are the slotted type, the following technique should be used to remove and replace the IC. When working with boards using the familiar round hole, use the standard technique as outlined in paragraphs 5 and 6 above.

### Removal

1. Desolder and straighten each IC lead in one operation by gently prying up on the lead with the soldering iron tip as the solder melts.
2. Draw away the melted solder with an anti-static suction-type solder removal device (or with solder braid) before removing the IC.

### Replacement

1. Carefully insert the replacement IC in the circuit board.
2. Carefully bend each IC lead against the circuit foil pad and solder it.
3. Clean the soldered areas with a small wire-bristle brush. (It is not necessary to reapply acrylic coating to the areas).

### "Small-Signal" Discrete Transistor

#### Removal/Replacement

1. Remove the defective transistor by clipping its leads as close as possible to the component body.
2. Bend into a "U" shape the end of each of three leads remaining on the circuit board.
3. Bend into a "U" shape the replacement transistor leads.
4. Connect the replacement transistor leads to the corresponding leads extending from the circuit board and crimp the "U" with long nose pliers to insure metal to metal contact then solder each connection.

### Power Output, Transistor Device

#### Removal/Replacement

1. Heat and remove all solder from around the transistor leads.
2. Remove the heat sink mounting screw (if so equipped).
3. Carefully remove the transistor from the heat sink of the circuit board.
4. Insert new transistor in the circuit board.
5. Solder each transistor lead, and clip off excess lead.
6. Replace heat sink.

### Diode Removal/Replacement

1. Remove defective diode by clipping its leads as close as possible to diode body.
2. Bend the two remaining leads perpendicular y to the circuit board.
3. Observing diode polarity, wrap each lead of the new diode around the corresponding lead on the circuit board.
4. Securely crimp each connection and solder it.
5. Inspect (on the circuit board copper side) the solder joints of the two "original" leads. If they are not shiny, reheat them and if necessary, apply additional solder.

### Fuse and Conventional Resistor

#### Removal/Replacement

1. Clip each fuse or resistor lead at top of the circuit board hollow stake.
2. Securely crimp the leads of replacement component around notch at stake top.
3. Solder the connections.

**CAUTION:** Maintain original spacing between the replaced component and adjacent components and the circuit board to prevent excessive component temperatures.

### Circuit Board Foil Repair

Excessive heat applied to the copper foil of any printed circuit board will weaken the adhesive that bonds the foil to the circuit board causing the foil to separate from or "lift-off" the board. The following guidelines and procedures should be followed whenever this condition is encountered.

#### At IC Connections

To repair a defective copper pattern at IC connections use the following procedure to install a jumper wire on the copper pattern side of the circuit board. (Use this technique only on IC connections).

1. Carefully remove the damaged copper pattern with a sharp knife. (Remove only as much copper as absolutely necessary).
2. Carefully scratch away the solder resist and acrylic coating (if used) from the end of the remaining copper pattern.
3. Bend a small "U" in one end of a small gauge jumper wire and carefully crimp it around the IC pin. Solder the IC connection.
4. Route the jumper wire along the path of the out-away copper pattern and let it overlap the previously scraped end of the good copper pattern. Solder the overlapped area and clip off any excess jumper wire.

#### At Other Connections

Use the following technique to repair the defective copper pattern at connections other than IC Pins. This technique involves the installation of a jumper wire on the component side of the circuit board.

1. Remove the defective copper pattern with a sharp knife. Remove at least 1/4 inch of copper, to ensure that a hazardous condition will not exist if the jumper wire opens.
2. Trace along the copper pattern from both sides of the pattern break and locate the nearest component that is directly connected to the affected copper pattern.
3. Connect insulated 20-gauge jumper wire from the lead of the nearest component on one side of the pattern break to the lead of the nearest component on the other side. Carefully crimp and solder the connections.  
**CAUTION:** Be sure the insulated jumper wire is dressed so the it does not touch components or sharp edges.

# SPECIFICATION

## 1. Application range

This specification is applied to the UW92J chassis.

## 2. General Specification

No.	Item	Specification	Remarks		
1	Input	HDMI1	Maximum Resolution	3840x2160@60Hz	* HDMI Cable Length Spec - 3840X2160 60hz(594MHz) : 3m - 3840X2160 30hz(297MHz) : 10m - 1920X1080 60hz(148.5Mhz) : 15m
			Recommend Resolution	3840x2160@60Hz	
			HDCP Support	HDCP2.2 & HDCP1.4	
			Color Format & Depth	4K@60/50Hz	
		4K@30/25Hz		RGB444/YCbCr444, 8/10/12bits YCbCr422 12bits	
		HDMI2	Maximum Resolution	3840x2160@60Hz	
			Recommend Resolution	3840x2160@60Hz	
			HDCP Support	HDCP2.2 & HDCP1.4	
			Color Format & Depth	4K@60/50Hz	
		4K@30/25Hz		RGB444/YCbCr444, 8/10/12bits YCbCr422 12bits	
		HDMI3	Maximum Resolution	3840x2160@60Hz	
			Recommend Resolution	3840x2160@60Hz	
	HDCP Support		HDCP2.2 & HDCP1.4		
	Color Format & Depth		4K@60/50Hz	RGB444/YCbCr444, 8bits YCbCr422 12bits YCbCr420 8/10/12bits	
		4K@30/25Hz	RGB444/YCbCr444, 8/10/12bits YCbCr422 12bits		
	USB(1)	USB Version	2.0		
	USB(2)	USB Version	2.0		
	RS232C In	UART Comm. w/ IR Daisy Chain		4P, 3.5mm Phone Jack	
	IR/Brightness Sensor	Type	Inner IR		
		IR Receiver			
Brightness sensor		CM3232			
LAN	RJ45, 100Base-T(100Mbps) only		SuperSign CMS / SuperSign Control / SuperSign Control+		

No	Item		Specification		Remarks
2	Output	Speaker Out	Type	Built-in	* Measured condition - USB(Music) : - 9dB - USB(Movie/AC3), HDMI(Music): -12dB - HDMI(PCM 2ch): -20dB
			Impedance	Typ. 6Ω	
			Output mode	BTL	
			Output Power	10W + 10W	
	Audio Out	Output type	Single Ended(L/R Stereo)	3P, 3.5mm Phone Jack	
		Output level	Typ. 0.5Vrms ± 10%		
		Supporting mode	Off / Fixed / Variable		
RS232C Out	UART Comm. w/ IR Daisy Chain		4P, 3.5mm Phone Jack		
3	Special Feature	Temp. Sensor	MM3286CFBE : 85 °C Protection		Main Board-in
		Wi-Fi/BT	Wi-Fi	802.11ac, 802.11n	Built-in (LGSBWAC72)
			BT	Version 4.0, Support Beacon	
		Logo Detachable	Yes		
4	Video signal	Operating Frequency	Horizontal frequency	30 - 83 kHz	Ultra Deep Color Off(3G) All Inputs
				30 - 136 kHz	Ultra Deep Color On(6G) HDMI1/2/3
			Vertical frequency	56 - 60 Hz	
				58 - 62 Hz	HDMI1/2/3
			Synchronization	Separate Sync, Digital	
5	Remote control		Wireless Remote Control(Infrared Radiation)		LG Code
	REMOCON Working Sensitivity, Straight		Working Sensitivity, Straight	Min. 12m	
	REMOCON Working Sensitivity, L/R		Working Sensitivity, L/R (30°)	Min. 9m	
6	Local Key		Power On/Off only		OneKey
7	Input Change Time		HDMI 1 / 2	3.0 sec + 10% below	1920x1080@60Hz (1080p@60Hz)
8	RTC Clock Accuracy		± 3sec during 24 hours		

No	Item	Specification				Remarks	
		Min	Typ	Max			
9	Power ON Screen Mute Time			8	sec		
10	Standby Discharge Time	On Condition : No more than 1s, Off Condition : No more than 3s					
11	Module Life Time	30,000	50,000		Hrs		
12	Uniformity	340	425		cd/m2		
13	Environment Condition	Operation Temperature	0		40	deg	LGE Specification
		Operation Humidity	10		80	%	LGE Specification
		Storage Temperature	-20		60	deg	LGE Specification
		Storage Humidity	5		85	%	LGE Specification
14	Absolute maximum rating	Voltage(2 port)	2500Vac or 3540Vdc/1sec				
		Current	100 mA (AC) / 10 mA(DC)		mA		
15	Tilt(Facedown)			-	°(degree)	-	

### 3. Supporting Resolution (Signal Timing)

#### 3.1. HDMI(PC Mode)

No.	Section	Pol.	Dot Clock [MHz]	Frequency [kHz]/[Hz]	Total Cycle (E)	Display (A)	Front Porch(B)	Sync. (D)	Back Porch(F)	Resolution	Support
1	H(Pixels)	+	40	37.879	1056	800	40	128	88	800 x 600	All inputs
	V(Lines)	+		60.317	628	600	1	4	23		
2	H(Pixels)	-	65	48.363	1344	1024	24	136	160	1024 x 768	
	V(Lines)	-		60	806	768	3	6	29		
3	H(Pixels)	+	74.5	44.772	1664	1280	64	128	192	1280 x 720	
	V(Lines)	+		59.855	748	720	3	5	20		
4	H(Pixels)	+	108	63.981	1688	1280	48	112	248	1280 x 1024	
	V(Lines)	+		60.02	1066	1024	1	3	38		
5	H(Pixels)	-	146.25	65.29	2240	1680	104	176	280	1680 x 1050	
	V(Lines)	+		59.954	1089	1050	3	6	30		
6	H(Pixels)	+	148.5	67.5	2200	1920	88	44	88	1920 x 1080	
	V(Lines)	+		60	1125	1080	4	5	46		
7	H(Pixels)	+	297	67.5	4400	3840	176	88	296	3840 x 2160	HDMI1/2/3
	V(Lines)	+		30	2250	2160	8	10	72		
8	H(Pixels)	+	594	135	4400	3840	176	88	296	3840 x 2160	HDMI1/2/3
	V(Lines)	+		60	2250	2160	8	10	72		

#### 3.2. HDMI (DTV Mode)

No.	H-freq(kHz)	V-freq(Hz)	Remarks	Resolution	Support
1	31.5	60	EDTV 480p	480/60P	O
2	31.25	50	EDTV 576p	576/50P	O
3	37.5	50	HDTV 720p	720/50P	O
4	45	60	HDTV 720p	720/60P	O
5	28.1	50	HDTV 1080i 50Hz	1080/50i	O
6	33.75	60	HDTV 1080i 60Hz	1080/60i	O
7	56.25	50	HDTV 1080P 50Hz	1080/50P	O
8	67.432	59.94	HDTV 1080P 60Hz	1080/60P	O
9	67.5	60	HDTV 1080P 60Hz	1080/60P	O
10	67.5	30	UD 2160P 30Hz	2160/30P	HDMI1/2/3
11	112.5	50	UD 2160P 50Hz	2160/50P	HDMI1/2/3
12	135	60	UD 2160P 60Hz	2160/60P	HDMI1/2/3

# SOFTWARE UPDATE

## 1. USB Download

- 1) Put the USB Stick to the USB socket
- 2) Automatically detecting update file in USB Stick  
- If your downloaded program version in USB Stick is Lower, it didn't work. But your downloaded version is Higher, USB data is automatically detecting (Download Version High & Power only mode, Set is automatically Download)
- 3) Show the message "Copying files from memory"

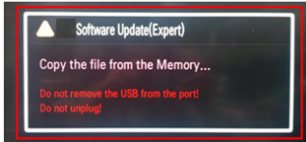

- 4) Updating is starting.

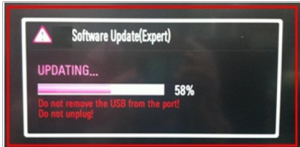

- 5) Updating Completed, The Signage Set will restart automatically

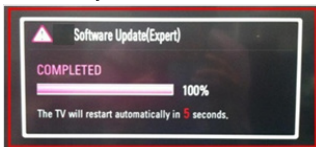

- 6) If your SIGNAGE SET is turned on, check your updated version and Tool option. (explain the Tool option, next stage)  
\* If downloading version is more high than your SIGNAGE SET have, SIGNAGE SET can lost all channel data. In this case, you have to channel recover. if all channel data is cleared, you didn't have a DTV/ATV test on production line.

\* After downloading, have to adjust TOOL OPTION again.

- 1) Push "IN-START" key in service remote control.
- 2) Select "Tool Option 1" and Push "OK" button.
- 3) Punch in the number. (Each model has their number.)

# BLOCK DIAGRAM

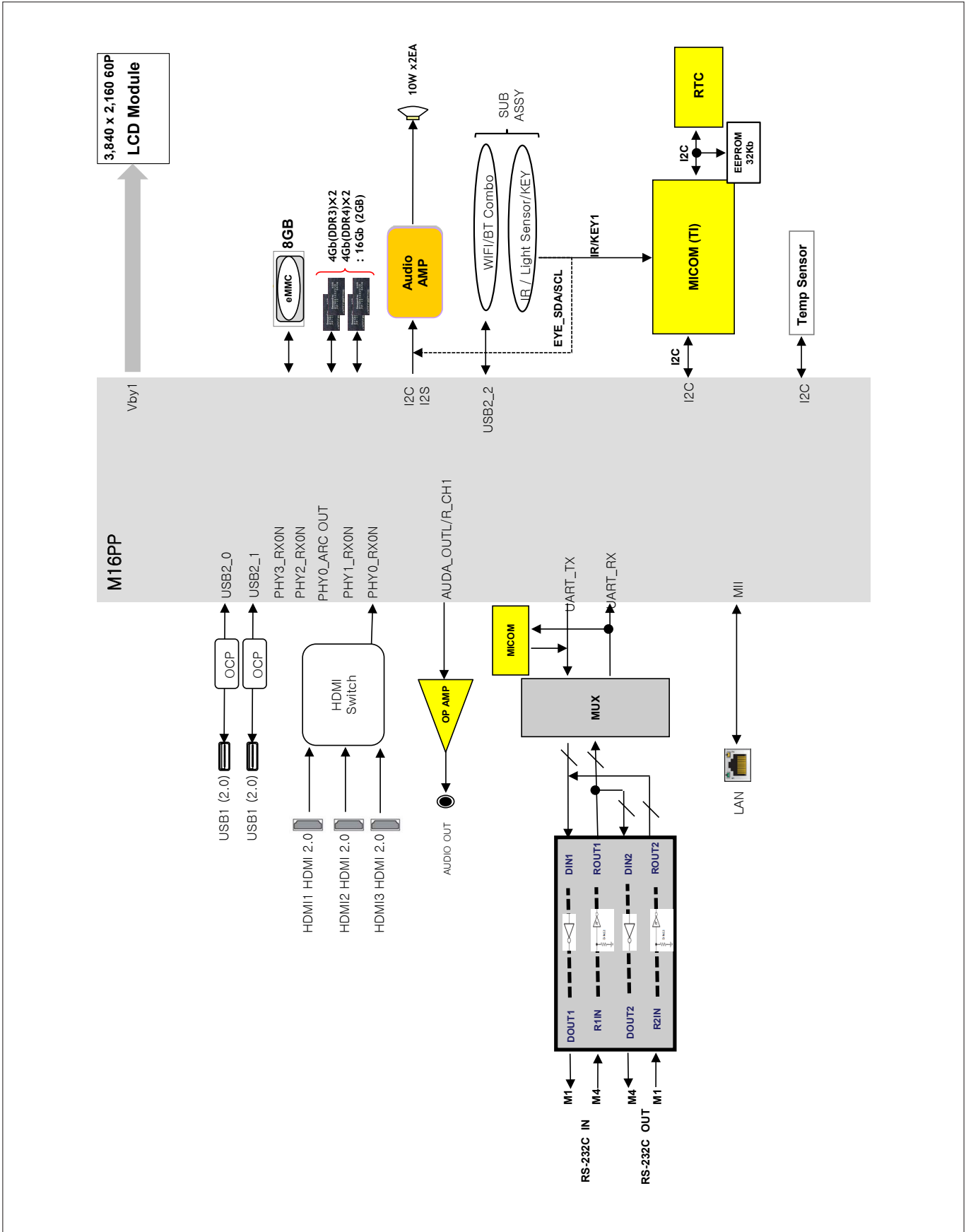



# **TROUBLE SHOOTING GUIDE**

# Contents of Standard Repair Process

No.	Error symptom (High category)	Error symptom (Mid category)	Page	Remarks
1	A. Video error	No video/Normal audio	1	
2		No video/No audio	2	
3		Color error	3	
4		Vertical/Horizontal bar, residual image, light spot, external device color error	4	
5	B. Power error	No power	5	
6		Off when on, off while viewing, power auto on/off	6	
7	C. Audio error	No audio/Normal video	7	
8		Wrecked audio/discontinuation/noise	8	
9	D. Function error	Remote control & Local switch checking	9	
10		Wifi operating checking	10	
11		External device recognition error	11	
12	E. Noise	Circuit noise, mechanical noise	12	
13	F. Exterior error	Exterior defect	13	

**First of all, Check whether there is SVC Bulletin in GSCS System for these model.**

Monitor Signage	Error symptom	A. Video error	Established date	
		No video/ Normal audio	Revised date	

**First of all, Check whether all of cables between board is inserted properly or not.  
(Main B/D↔ Power B/D, Power Cable, EPI Cable, FFC VBY1 Cable, Key Cable,,)**

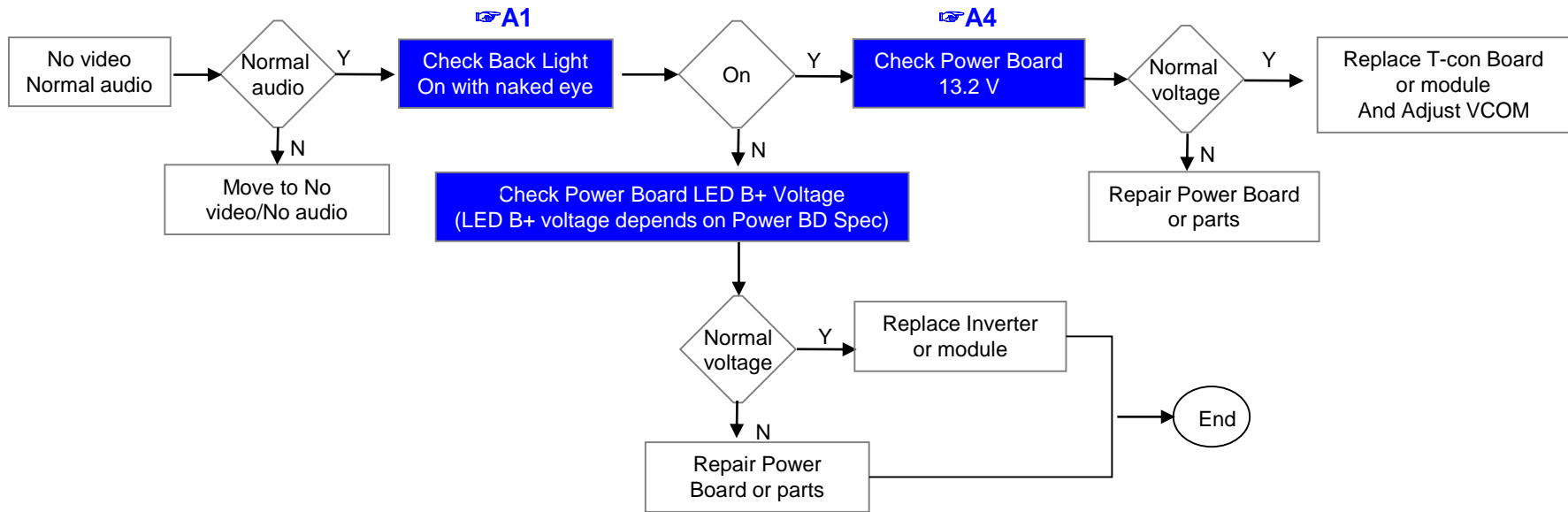

※Precaution    A5 & A3

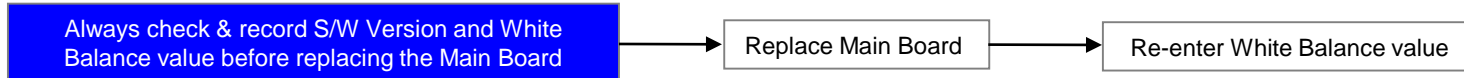

Monitor Signage	Error symptom	A. Video error	Established date		
		No video/ No audio	Revised date		2/13

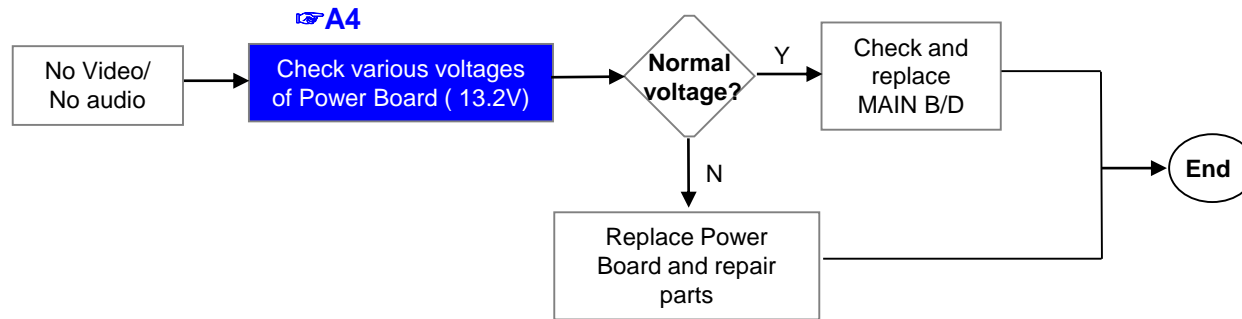

Standard Repair Process

Error symptom	<b>A. Video error</b>	Established date	
	Color error	Revised date	3/13

**A6**

Check color by input  
-External Input  
-HDMI

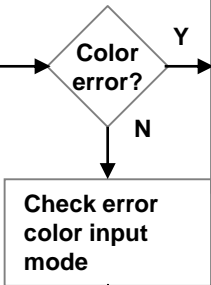

**A7**

※ Check and replace Link Cable (EPI or Vx1 Cable) and contact condition

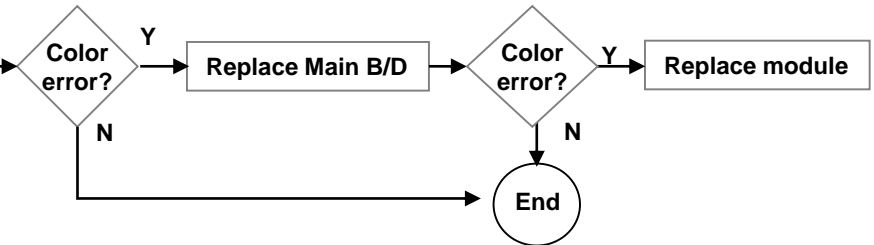

**A8**

Check Test pattern

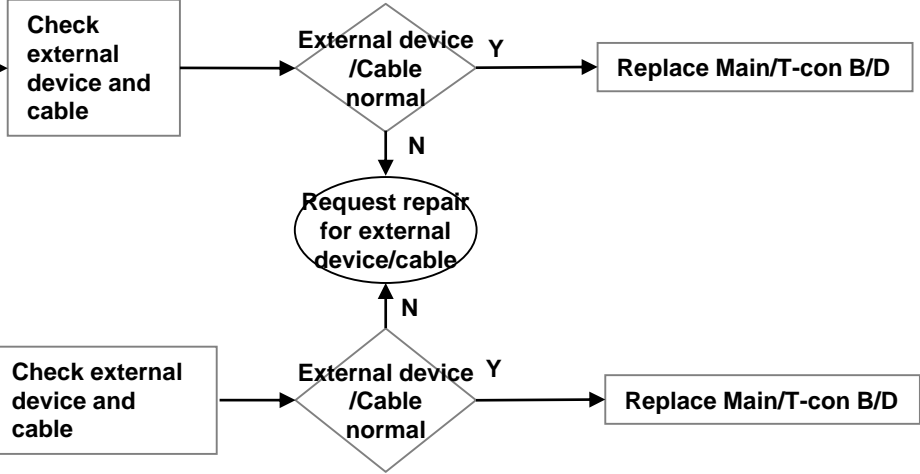
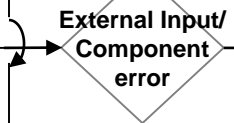

Error symptom	<b>A. Video error</b>	Established date	
	Vertical / Horizontal bar, residual image, light spot, external device color error	Revised date	4/13

### Vertical/Horizontal bar, residual image, light spot

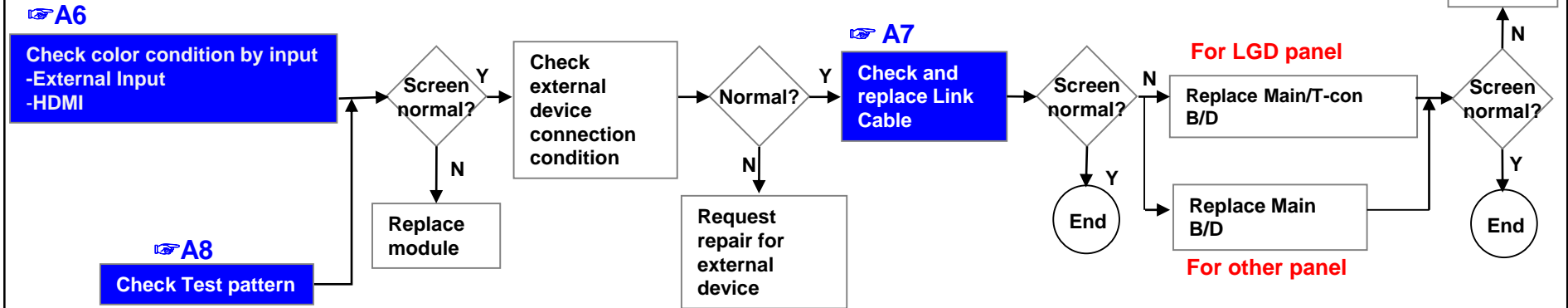

### External device screen error-Color error

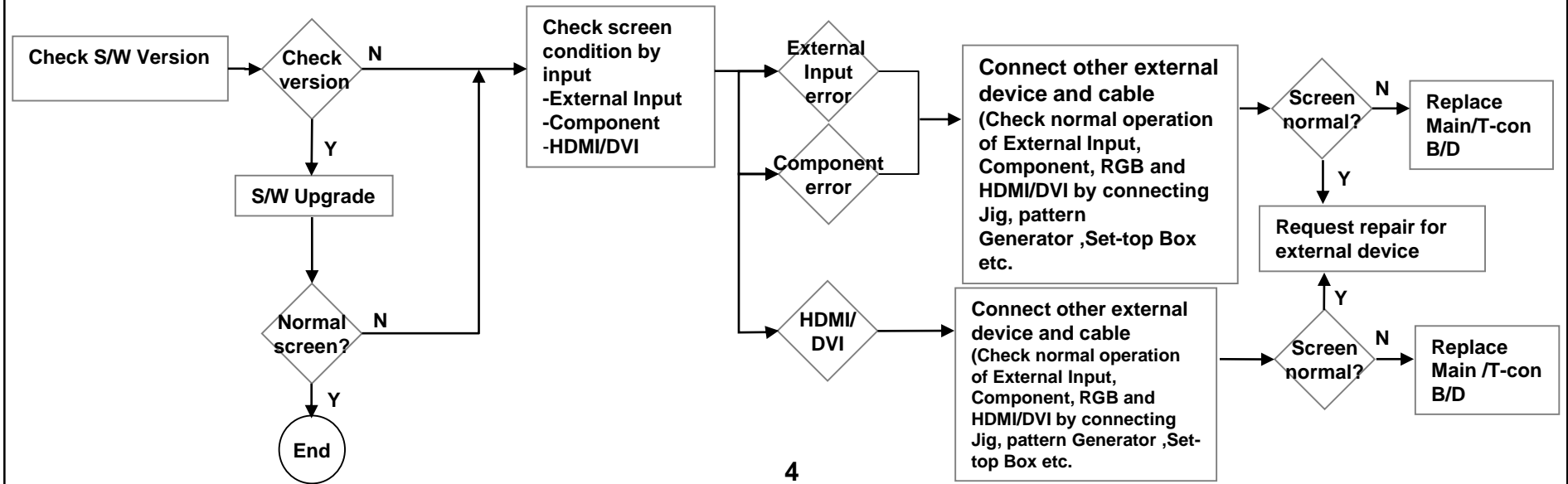

Monitor Signage	Error symptom	B. Power error	Established date	
		No power	Revised date	5/13

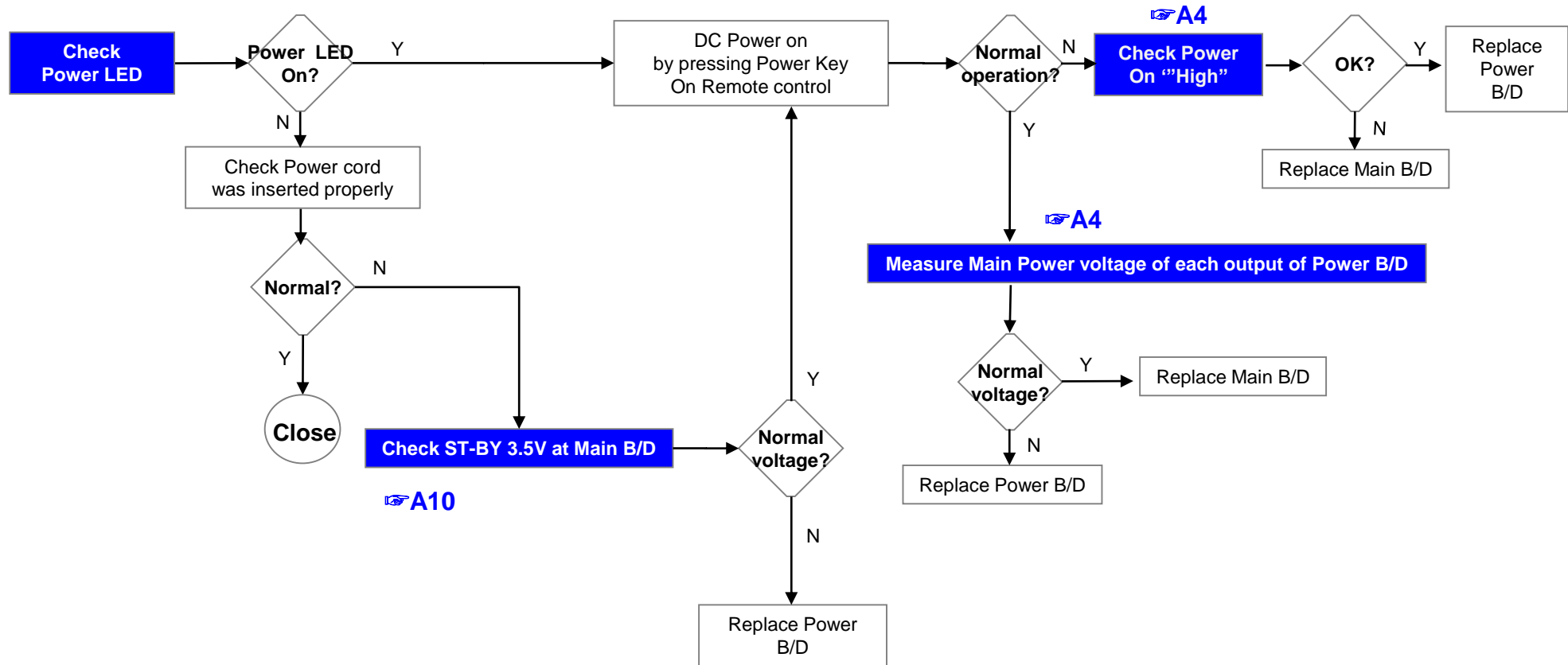

Standard Repair Process

Monitor Signage	Error symptom	B. Power error	Established date	
		Off when on, off while viewing, power auto on/off	Revised date	

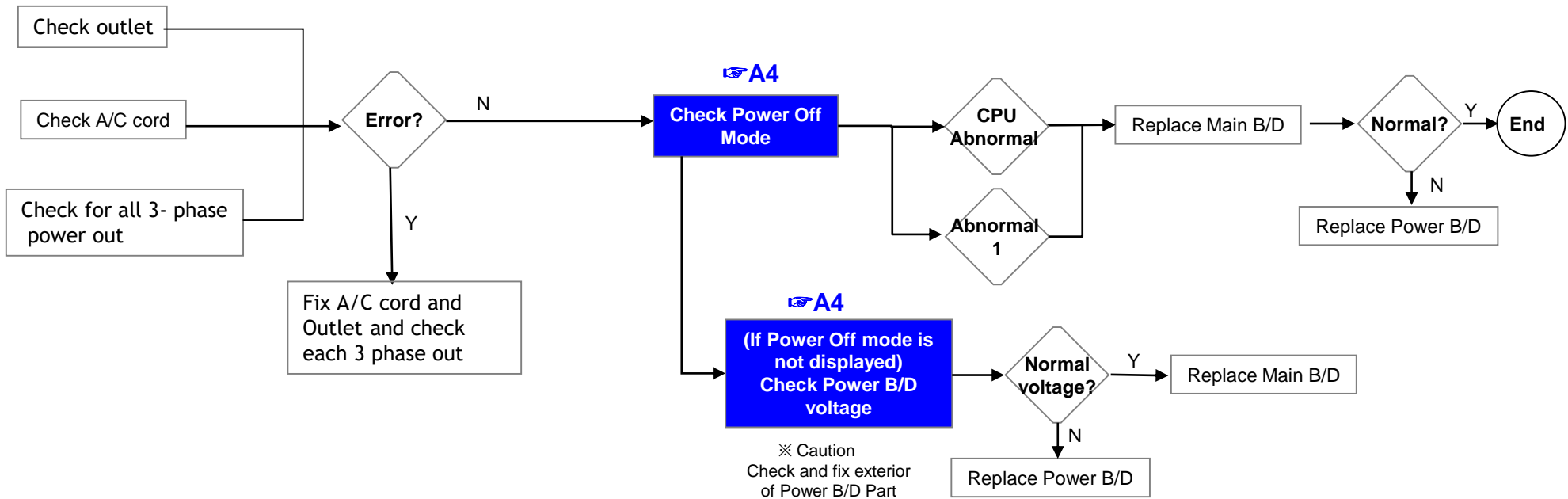

\* Please refer to the all cases which can be displayed on power off mode.

Status	Power off List	Explanation
Normal	"POWEROFF_REMOTEKEY"	Power off by REMOTE CONTROL
	"POWEROFF_OFFTIMER"	Power off by OFF TIMER
	"POWEROFF_SLEEPTIMER"	Power off by SLEEP TIMER
	"POWEROFF_INSTOP"	Power off by INSTOP KEY
	"POWEROFF_AUTOOFF"	Power off by AUTO OFF
	"POWEROFF_ONTIMER"	Power off by ON TIMER
	"POWEROFF_RS232C"	Power off by RS232C
	"POWEROFF_RESREC"	Power off by Reserved Record
	"POWEROFF_RECEND"	Power off by End of Recording
	"POWEROFF_SWDOWN"	Power off by S/W Download
	"POWEROFF_UNKNOWN"	Power off by unknown status except listed case
Abnormal	"POWEROFF_ABNORMAL1"	Power off by abnormal status except CPU trouble
	"POWEROFF_CPUABNORMAL"	Power off by CPU Abnormal

Standard Repair Process

Monitor Signage	Error symptom	<b>C. Audio error</b>	Established date		
		No audio/ Normal video	Revised date		7/13

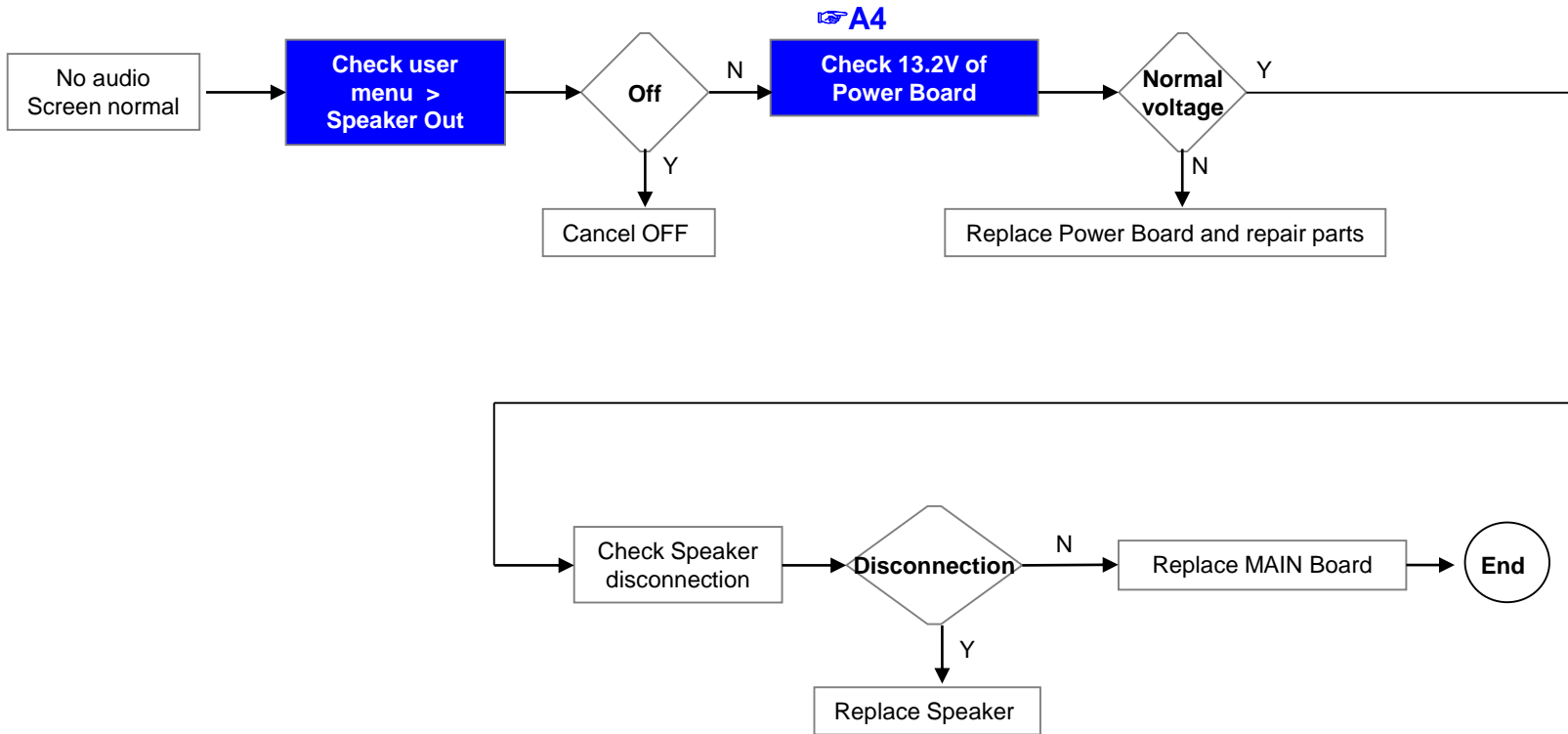

Monitor Signage	Error symptom	C. Audio error	Established date	
		Wrecked audio/ discontinuation/noise	Revised date	

→ abnormal audio/discontinuation/noise is same after “Check input signal” compared to No audio

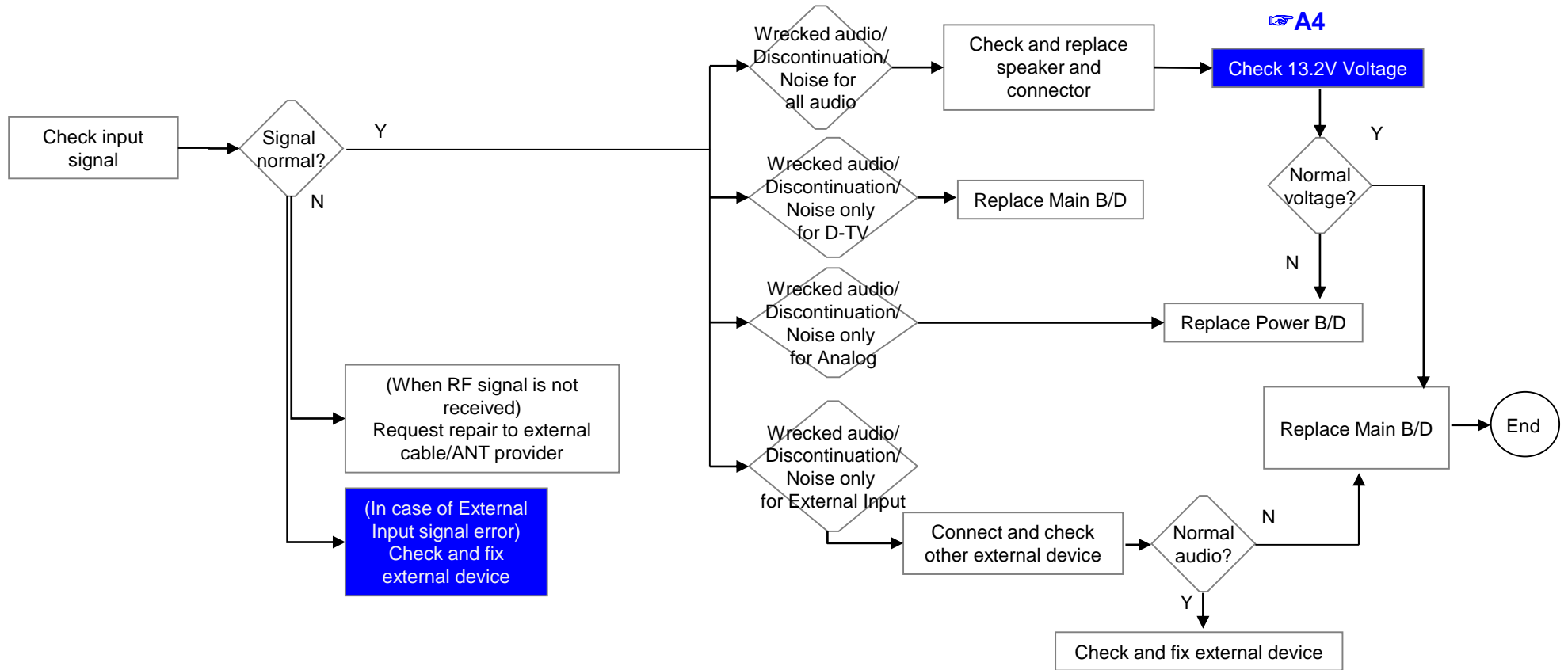

Monitor Signage	Error symptom	<b>D. General Function Problem</b>	Established date		
		Remote control & Local switch checking	Revised date		9/13

### 1. Remote control(R/C) operating error

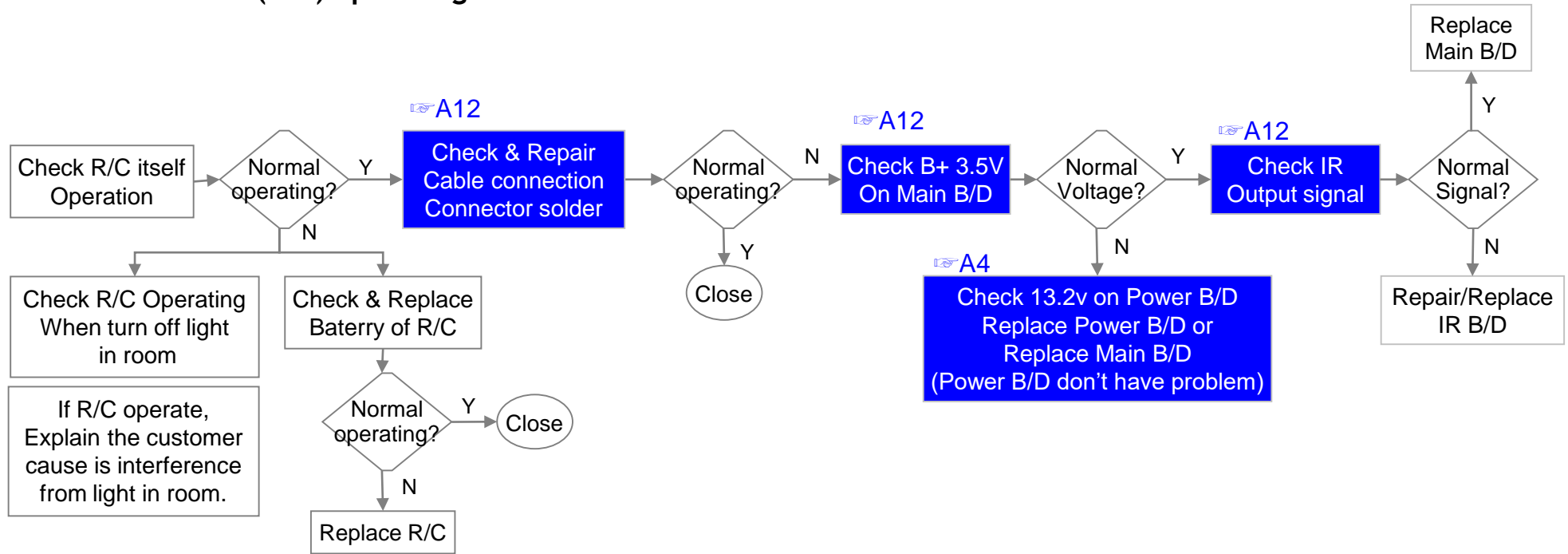

Error symptom	D. Function error	Established date	
	Wifi operating checking	Revised date	10/13

### 3.Wifi operating error

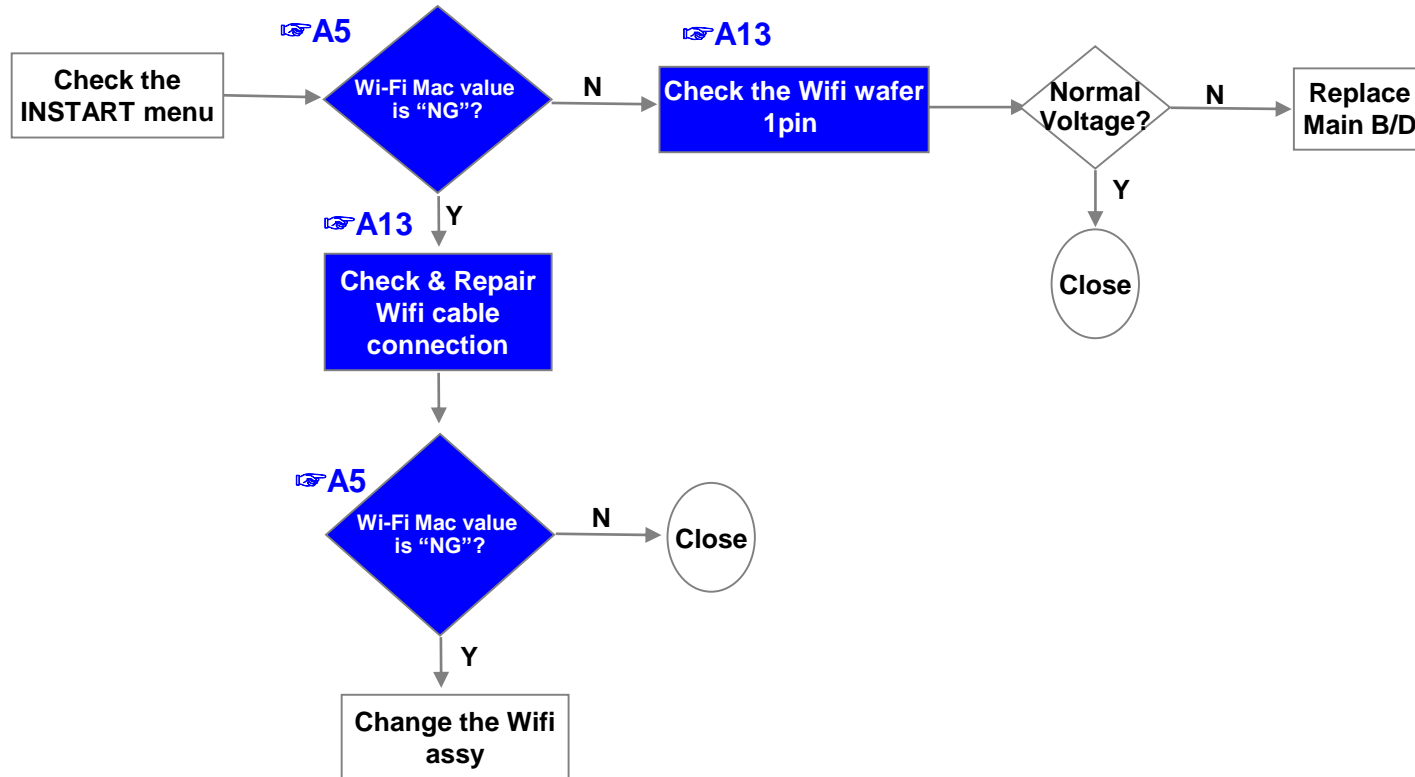

Monitor Signage	Error symptom	<b>D. Function error</b>	Established date	
		External device recognition error	Revised date	11/13

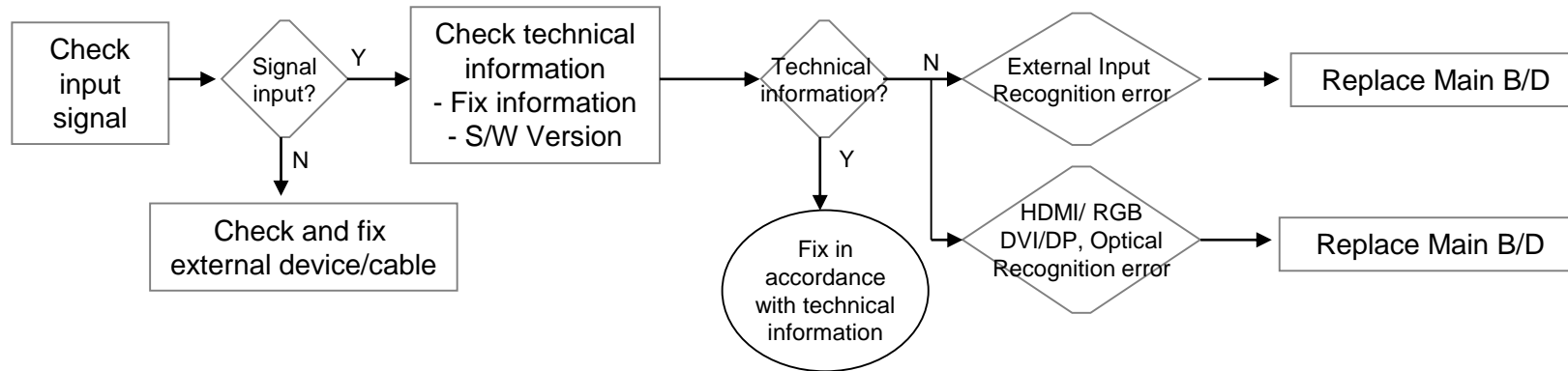

Monitor Signage	Error symptom	<b>E. Noise</b>	Established date	
		Circuit noise, mechanical noise	Revised date	12/13

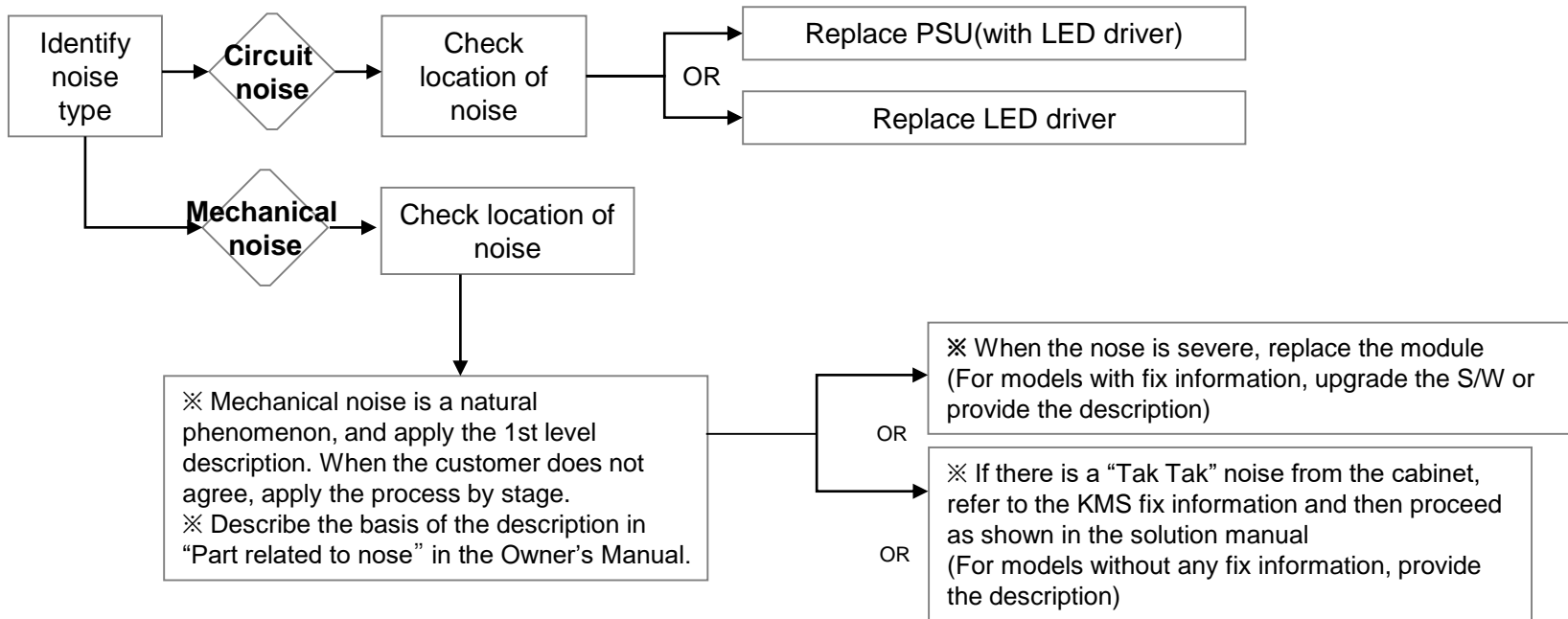

Monitor Signage	Error symptom	F. Exterior defect	Established date	
		Exterior defect	Revised date	13/13

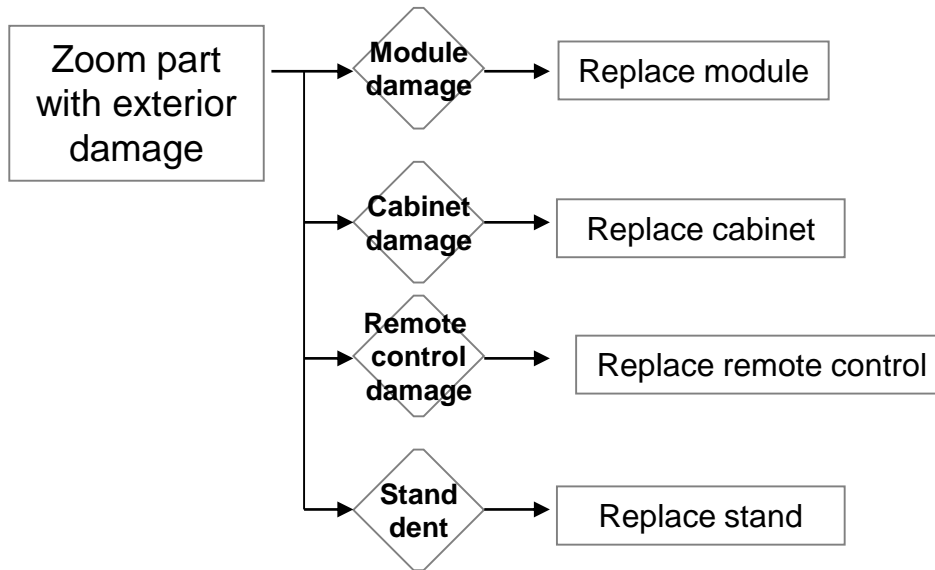

# Contents of Standard Repair Process Detail Technical Manual

No.	Error symptom	Content	Page	Remarks
1	A. Video error_ No video/Normal audio	Check LCD back light with naked eye	A1	
2		LED driver B+ measuring method	A2	
3		Check White Balance value	A3	
4		Power Board voltage measuring method	A4	
5	A. Video error_Color error	Version checking method	A5	
6		connection diagram	A6	
7		Check Link Cable reconnection condition	A7	
8		Adjustment Test pattern - ADJ Key	A8	
9	<b>&lt;Appendix&gt;</b> Defected Type caused by Main/ Inverter/ Module	Exchange VX1 or EPI Cable or Main B/D (1)	A-1/5	
10		Exchange VX1 or EPI Cable or Main B/D (2)	A-2/5	
11		Exchange LED driver Board (PSU)	A-3/5	
12		Exchange Module itself (1)	A-4/5	
13		Exchange Module itself (2)	A-5/5	

# Contents of Standard Repair Process Detail Technical Manual

Continued from previous page

No.	Error symptom	Content	Page	Remarks
14	B. Power error_No power	Check power input voltage and ST-BY 7.8V	A9 – A14	
15	B. Power error_Off when on, off while viewing	POWER OFF MODE checking method	A15	
16	C. Audio error_No audio/Normal video	Voltage and speaker checking method when there is no audio	A16	
17	D. Function error_ No response in remote control, key error	Remote control operation checking method	A17-A18	

# Standard Repair Process Detail Technical Manual

Monitor Signage	Error symptom	A. Video error_No video/Normal audio	Established date		
	Content	Check LCD back light with naked eye	Revised date		A1

<86UL3G >

<43/55/65UL3G >

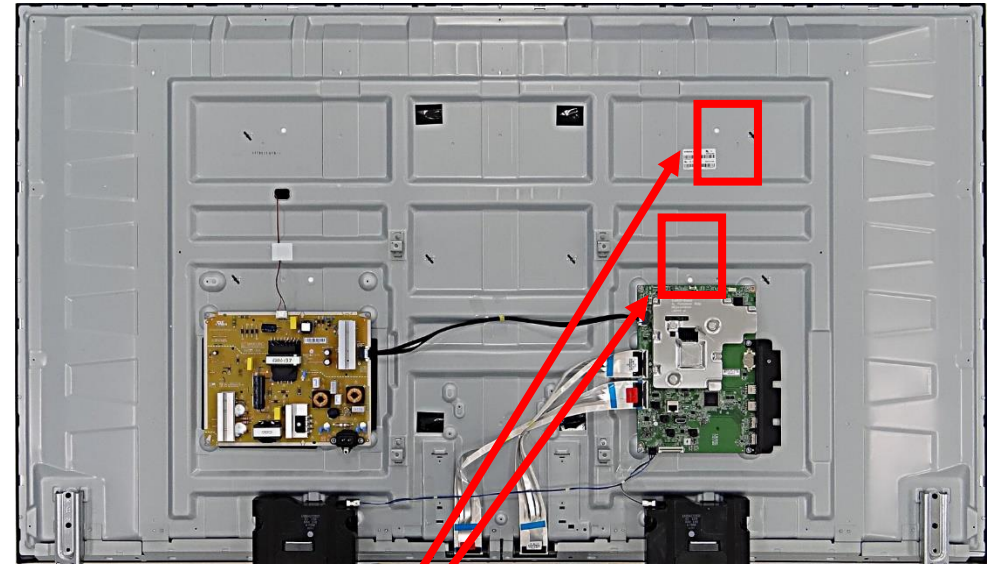
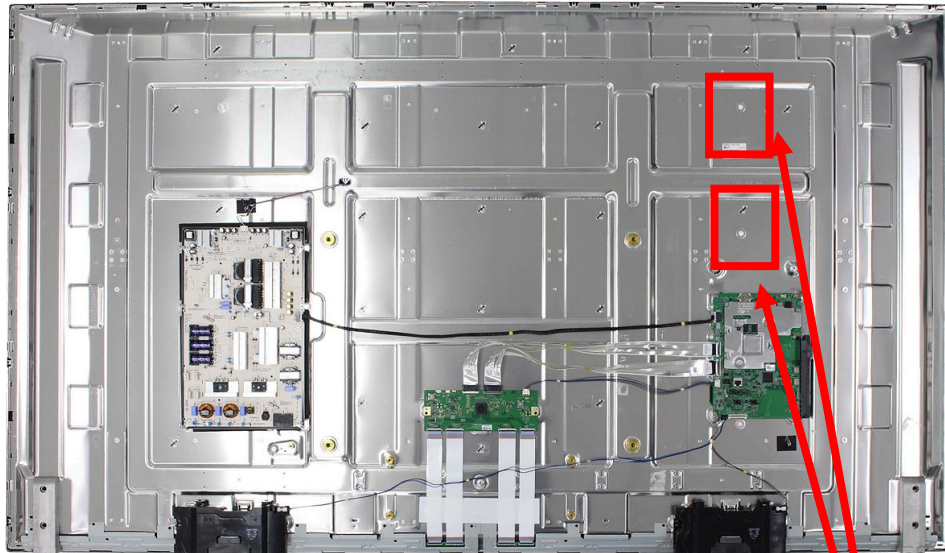

After turning on the power and disassembling the case, check with the naked eye, whether you can see light from module holes.

A1

# Standard Repair Process Detail Technical Manual

Monitor Signage	Error symptom	A. Video error_No video/Normal audio	Established date		
	Content	LED driver B+ measuring method	Revised date		A2

<86UL3G>

<43/55/65UL3G>

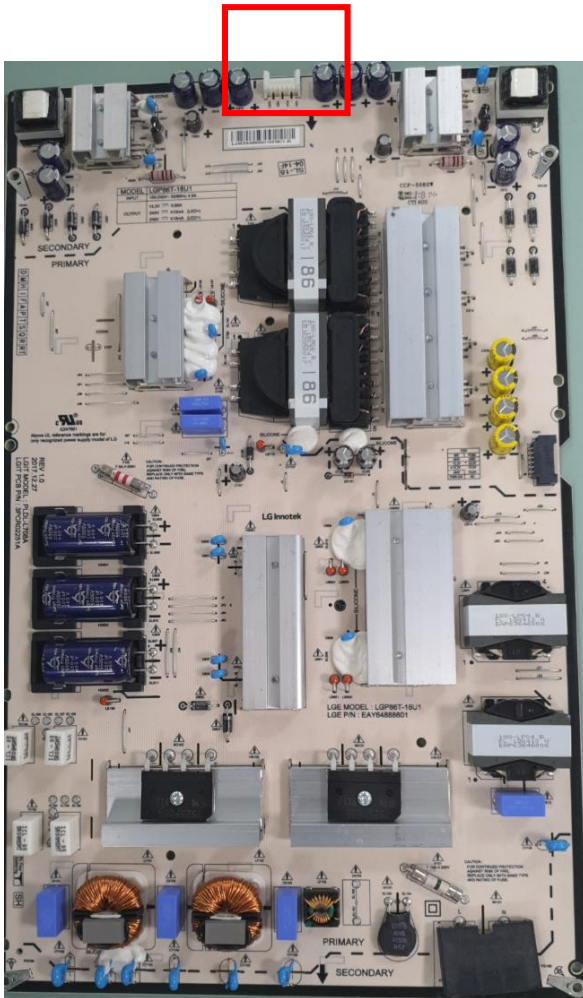

1. Check the Voltage between LED+ / LED-
2. The Voltage spec is in Power B/D spec sheet
3. Refer to the Power B/D Spec sheet

# Standard Repair Process Detail Technical Manual

Monitor Signage	Error symptom	A. Video error_No video/Normal audio	Established date		
	Content		Revised date		A3

<ALL MODELS>

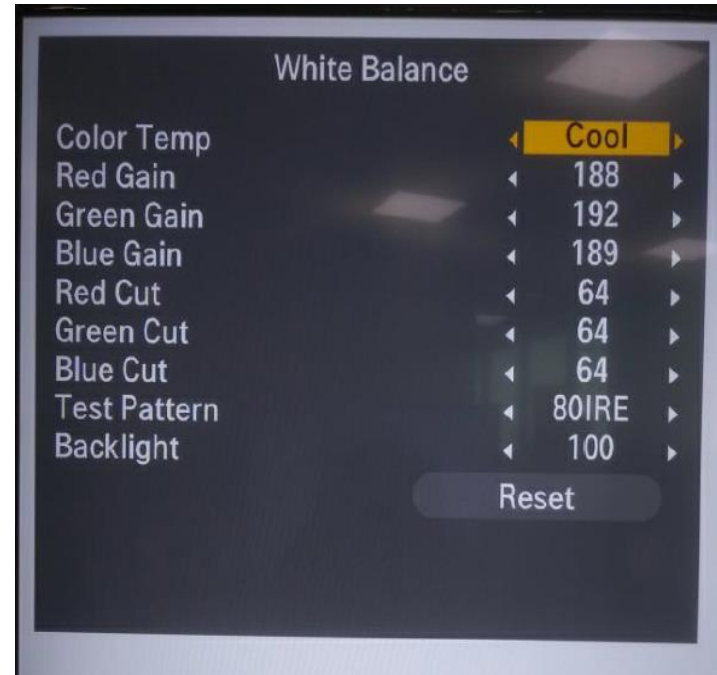
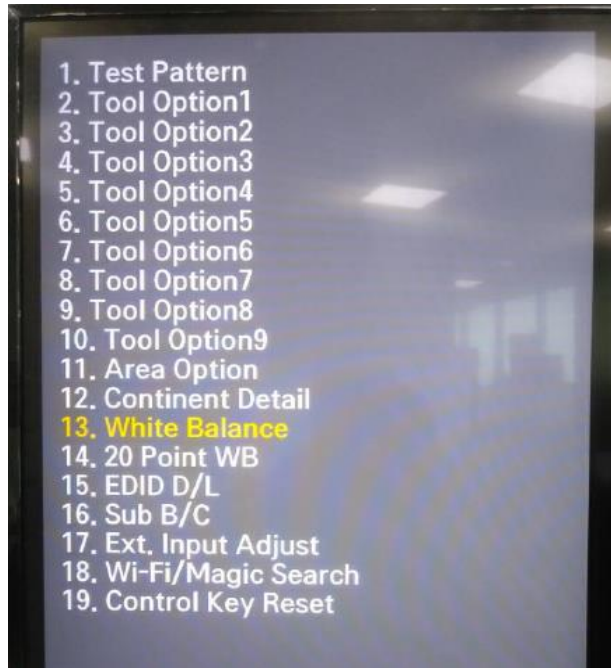

## Entry method

1. Press the ADJ button on the remote control for adjustment.
2. Enter into White Balance of item 14.
3. After recording the R, G, B (GAIN, Cut) value of Color Temp (Cool/Medium/Warm), re-enter the value after replacing the MAIN BOARD.

# Standard Repair Process Detail Technical Manual

Monitor Signage	Error symptom	A. Video error_No video/ Audio	Established date		
	Content	Power Board voltage measuring method	Revised date		A4

Check the 13.2V and PWR\_ON

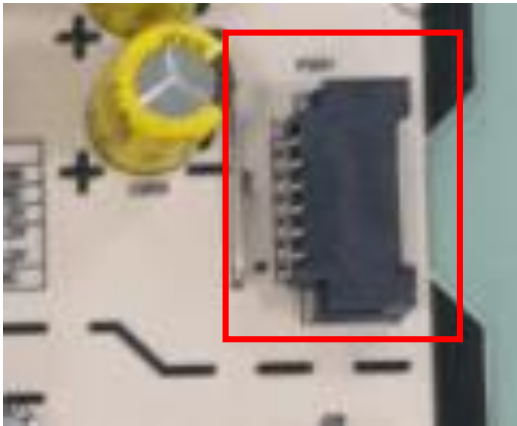

Pin No.	Signal	Pin No.	Signal
1	GND	2	GND
3	PWR_ON	4	P-DIM2
5	GND	6	13.2V
7	13.2V	8	13.2V
9	13.2V	10	13.2V
11	GND	12	GND
13	DRV_ON	14	P-DIM
15	GND	16	SCLK
17	V-SYNC	18	SIN

# Standard Repair Process Detail Technical Manual

Monitor Signage	Error symptom	A. Video error_Video error, video lag/stop	Established date		
	Content	Monitor Signage Version checking method	Revised date		A5

<ALL MODELS>

## 1. Checking method for remote control for adjustment

Version

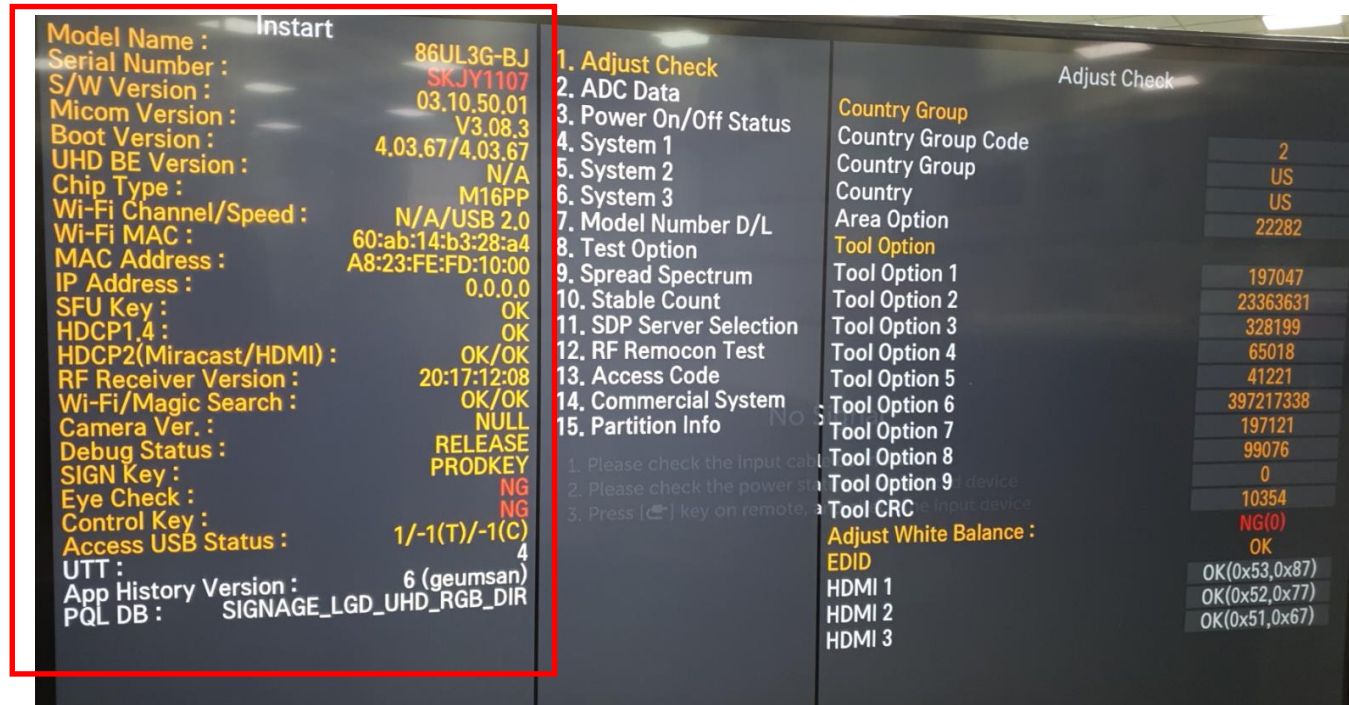

Press the IN-START with the remote control for adjustment

# Standard Repair Process Detail Technical Manual

Monitor Signage	Error symptom	A. Video error _Vertical/Horizontal bar, residual image, light spot	Established date		
	Content	Monitor signage connection diagram	Revised date		A6

<ALL MODELS>

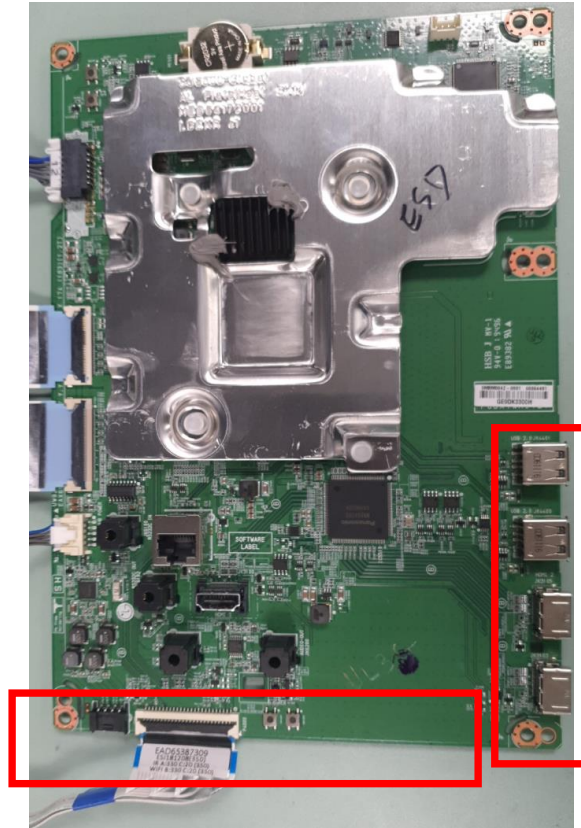

As the part connecting to the external input, check the screen condition by signal

A6

# Standard Repair Process Detail Technical Manual

Monitor Signage	Error symptom	A. Video error_Color error	Established date		
	Content	Check Link Cable reconnection condition	Revised date		A7

<50/75/86UL3G>

<43/55/65UL3G>

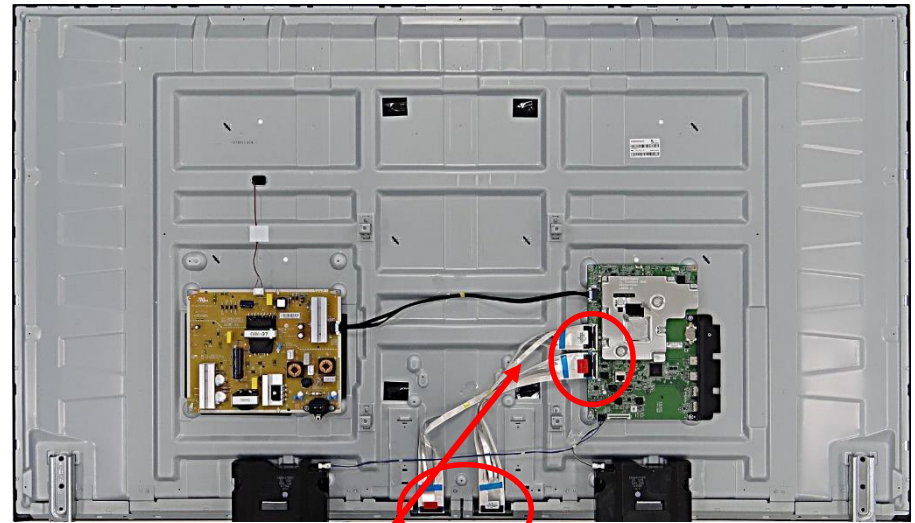
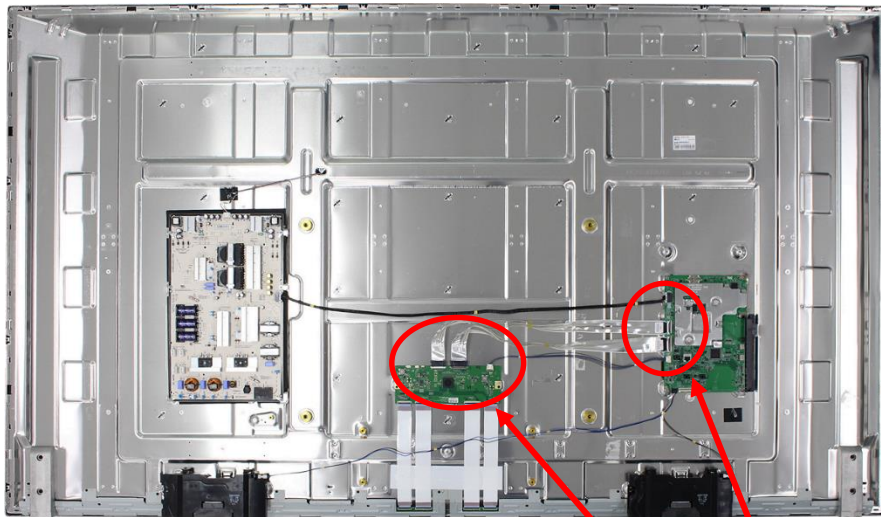

Check the contact condition of the Link Cable, especially dust or mis insertion.

A7

# Standard Repair Process Detail Technical Manual

Monitor Signage	Error symptom	A. Video error_Color error	Established date		
	Content	Adjustment Test pattern - ADJ Key	Revised date		A8

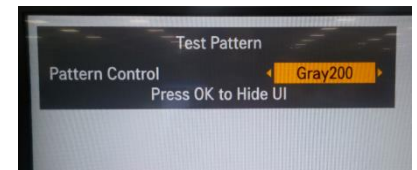
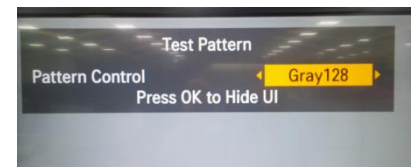
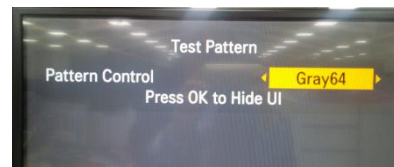
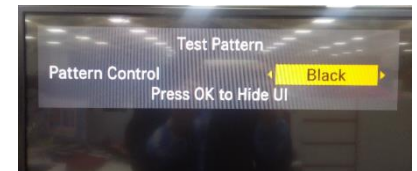
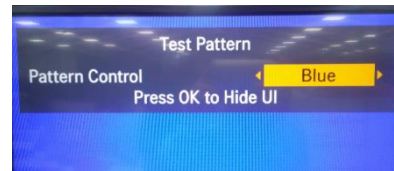
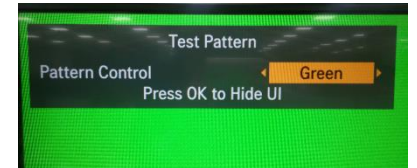
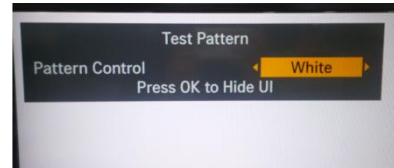
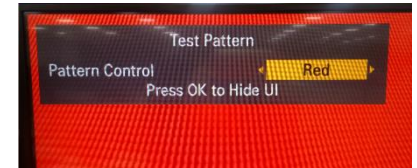
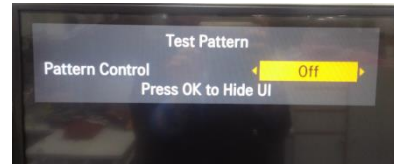
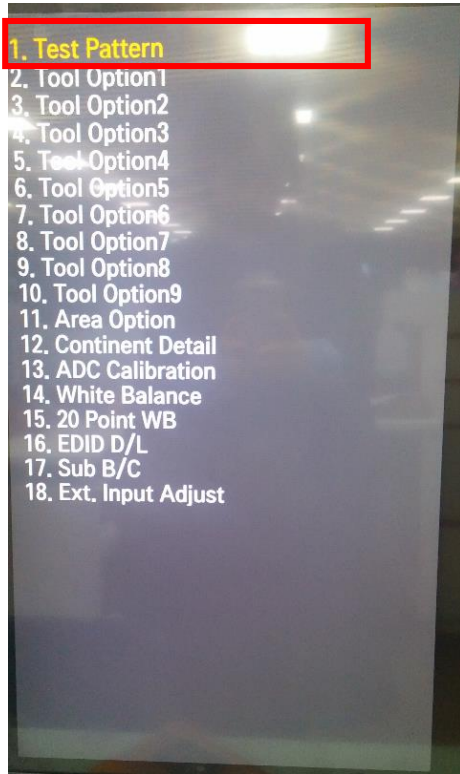

You can view 8 types of patterns using the ADJ Key

Checking item : 1. Defective pixel 2. Residual image 3. MODULE error (ADD-BAR,SCAN BAR..) 4.Video error (Classification of MODULE or Main-B/D)

# Appendix : Exchange VX1 or EPI Cable or Main B/D (1)



Solder defect, CNT Broken

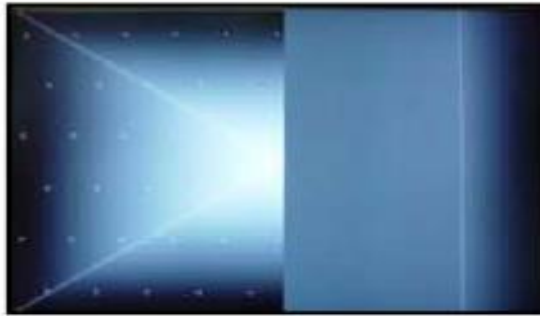

Solder defect, CNT Broken

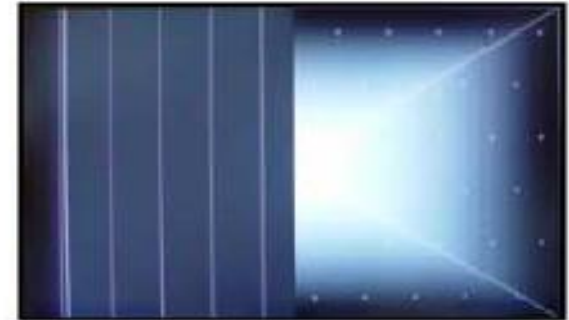

Solder defect, CNT Broken



Solder defect, CNT Broken



Solder defect, CNT Broken



Abnormal Power Section

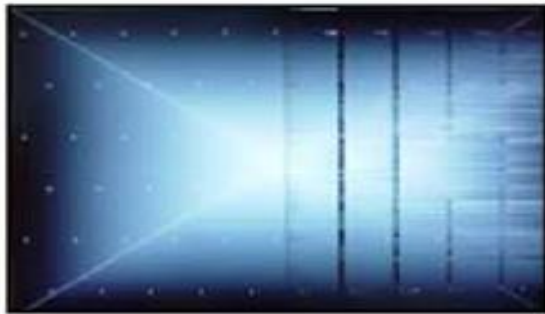

Solder defect, Short/Crack



Abnormal Power Section



Solder defect, Short/Crack

## Appendix : Exchange VX1 or EPI Cable or Main B/D (2)



Abnormal Power Section



Abnormal Power Section



Solder defect, Short/Crack



Solder defect, Short/Crack



Fuse Open, Abnormal power section



Abnormal Display

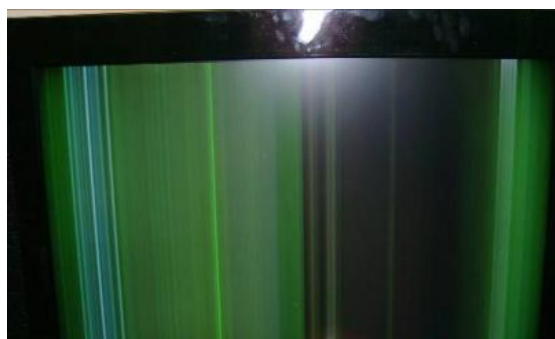

GRADATION



Noise



GRADATION

# Appendix : Exchange Power Board



No Light



Dim Light



Dim Light

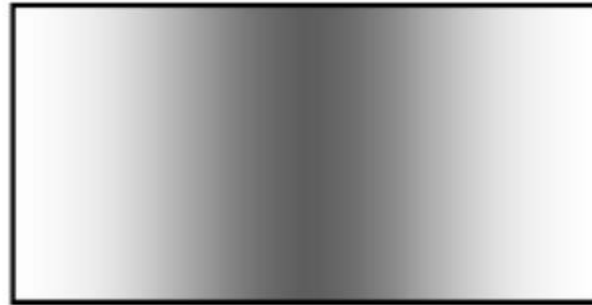

Dim Light



No picture/Sound Ok

## Appendix : Exchange the Module (1)



Panel Mura, Light leakage



Panel Mura, Light leakage



Press damage

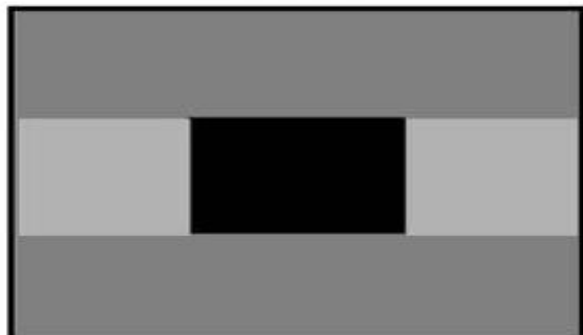

Crosstalk



Press damage



Crosstalk



Press damage

### Un-repairable Cases

In this case please exchange the module.

## Appendix : Exchange the Module (2)

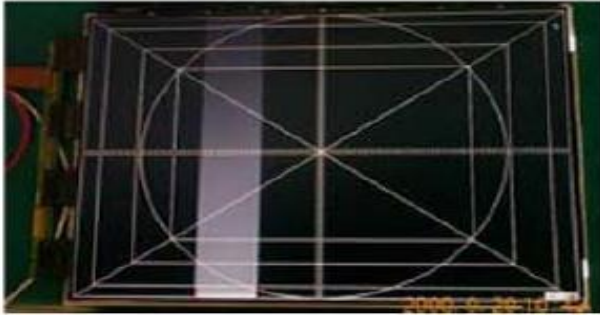

Vertical Block  
Source TAB IC Defect



Vertical Line  
Source TAB IC Defect



Vertical Block  
Source TAB IC Defect



Horizontal Block  
Gate TAB IC Defect



Horizontal Block  
Gate TAB IC Defect



Horizontal line  
Gate TAB IC Defect



Horizontal Block  
Gate TAB IC Defect

### Un-repairable Cases

In this case please exchange the module.

# Standard Repair Process Detail Technical Manual

	Error symptom	B. Power error _No power	Established date		
	Content	Check power input voltage and ST-BY 7.8V	Revised date		A9

SET Model	Power P/N, Name
43UL3G	EAY65170101, LGP43T-19U1

## Power Check Sequence

1. AC input Check : SK100 (100~240Vac)
2. PWR-ON Check : Check Hole
  - SET On : above 3V
  - SET St-by : 0V
3. 13.2V DC Check : D201 center Pin
  - SET On : 13.2V
  - SET St-by : 7.8V

## 4. MS Level Check : MS

MS Level	Range [V]	LED On/Off
MS (0V)	0 ~ 0.25	Off
MS (2V)	1.75 ~ 2.25	On (Home mode)
MS (3V)	2.75 ~ 3.25	On (Store Mode)

※ Home mode : General Customer  
Store mode : use Store

## 5. LED voltage Check : P801, Pin 1-7

Picture Condition : VIVID (Back light 100)		
Min	Typ.	Max
114 V	127 V	139 V

## Power Board Voltage / Current

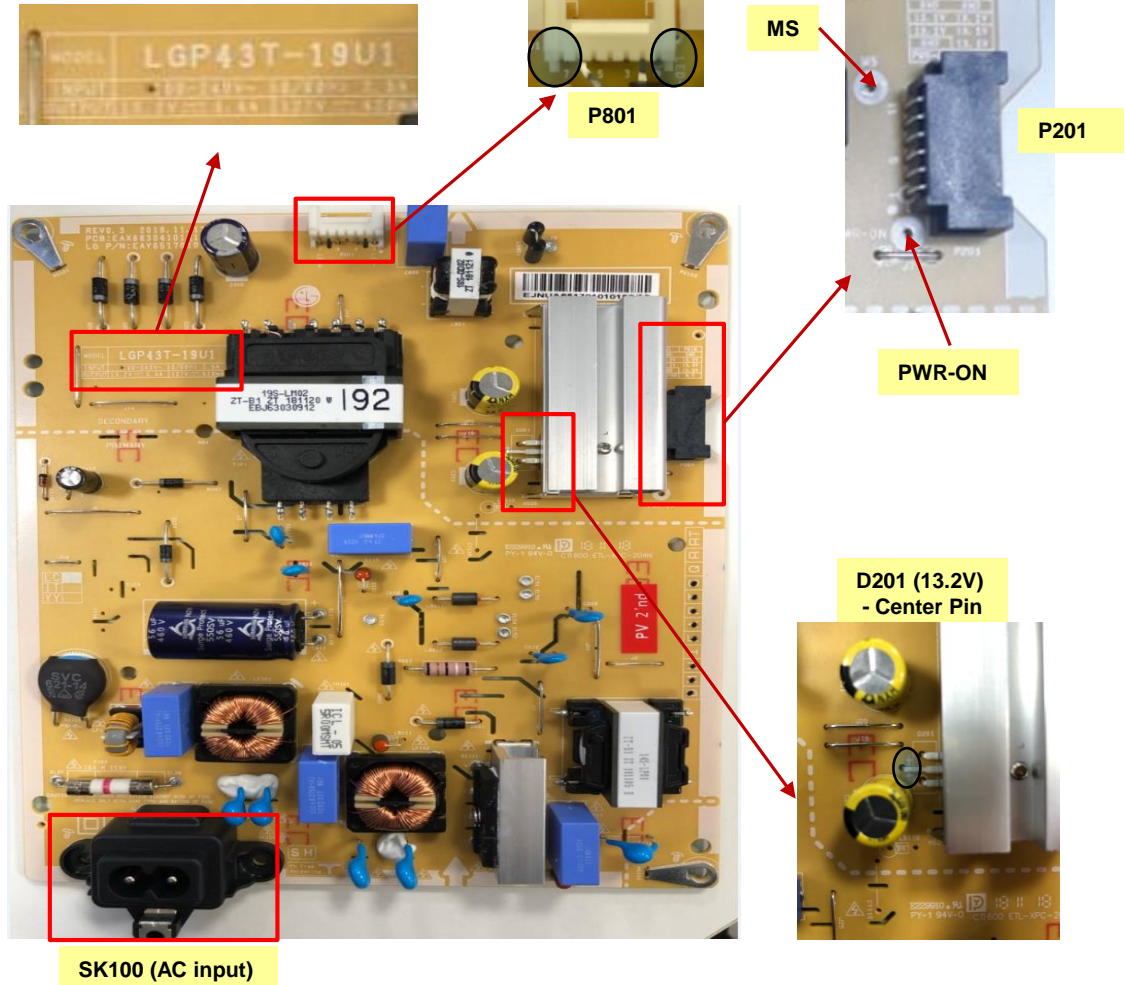

all condition meets, Power Board OK.

A9

# Standard Repair Process Detail Technical Manual

	Error symptom	B. Power error _No power	Established date	
	Content	Check power input voltage and ST-BY 7.8V	Revised date	A10

SET Model	Power P/N, Name
50UL3G	EAY65769221 , LGP50T-20U1

## Power Board Voltage / Current

### Power Check Sequence

1. AC input Check : SK100 (100~240Vac)
2. PWR-ON Check : J3
  - SET On : above 3V
  - SET St-by : 0V
3. 13.2V DC Check : D201 center Pin
  - SET On : 13.2V
  - SET St-by : 7.8V

### 4. MS Level Check : MS Check Hole

MS Level	Range [V]	LED On/Off
MS (0V)	0 ~ 0.25	Off
MS (2V)	1.75 ~ 2.25	On (Home mode)
MS (3V)	2.75 ~ 3.25	On (Store Mode)

※ Home mode : General Customer  
Store mode : use Store

### 5. LED voltage Check : P801, Pin 1-7

Picture Condition : VIVID (Back light 100)		
Min	Typ.	Max
152.1 V	169 V	185.9 V

all condition meets, Power Board OK.

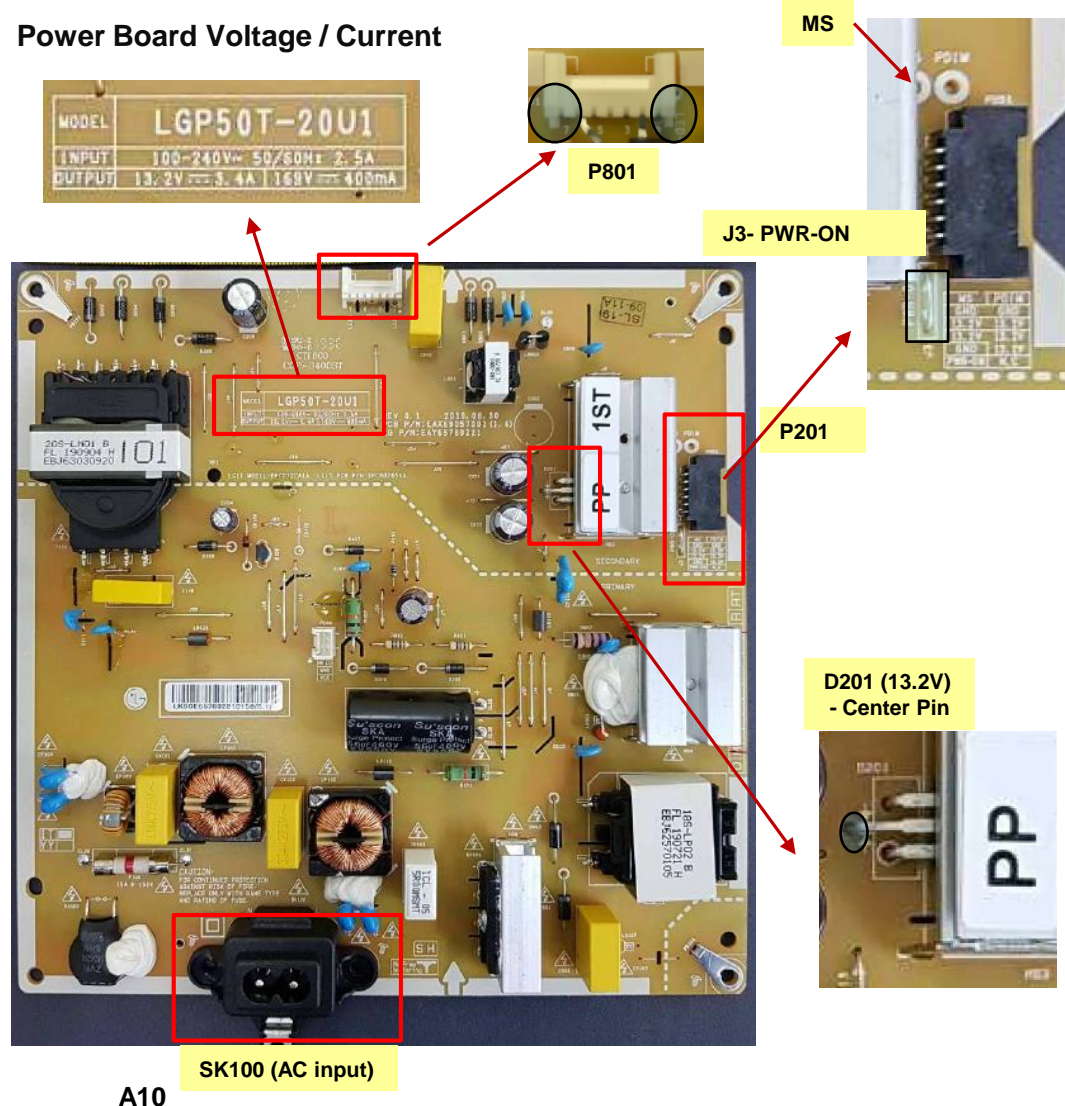

# Standard Repair Process Detail Technical Manual

	Error symptom	B. Power error _No power	Established date	
	Content	Check power input voltage and ST-BY 7.8V	Revised date	A11

SET Model	Power P/N, Name
55UL3G	EAY65149301, LGP55T-19U1

## Power Check Sequence

1. AC input Check : SK100 (100~240Vac)
2. PWR-ON Check : J30  
 - SET On : above 3V  
 - SET St-by : 0V
3. 13.2V DC Check : D201 center Pin  
 - SET On : 13.2V  
 - SET St-by : 7.8V

## 4. MS Level Check : MS Check Hole

MS Level	Range [V]	LED On/Off
MS (0V)	0 ~ 0.25	Off
MS (2V)	1.75 ~ 2.25	On (Home mode)
MS (3V)	2.75 ~ 3.25	On (Store Mode)

※ Home mode : General Customer  
 Store mode : use Store

## 5. LED voltage Check : P801, Pin 1-7

Picture Condition : VIVID (Back light 100)	
Min	Max
175.5V	214.5V

## Power Board Voltage / Current

MODEL	LGP55T-19U1
INPUT	100-240V~ 50/60Hz 2.5A
OUTPUT	13.2V --- 3.4A   195V --- 440mA

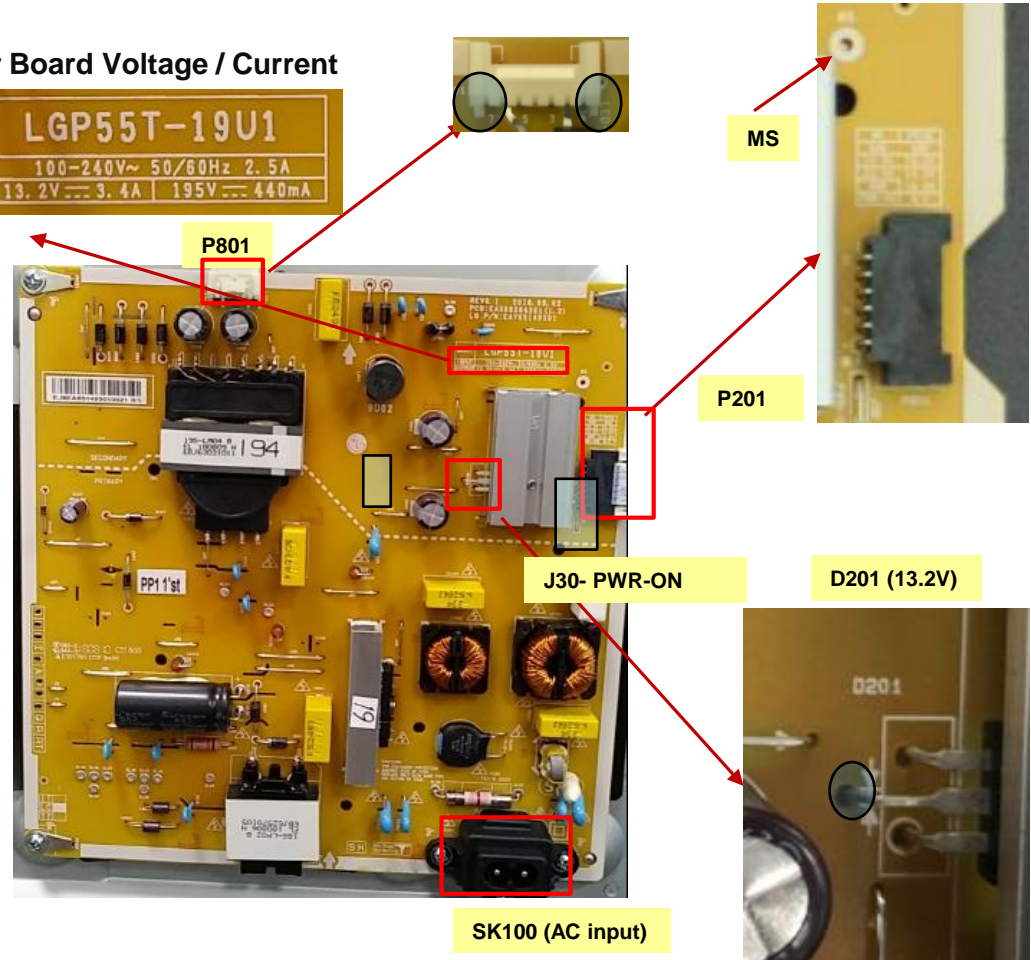

all condition meets, Power Board OK.

A11

# Standard Repair Process Detail Technical Manual

	Error symptom	B. Power error _No power	Established date	
	Content	Check power input voltage and ST-BY 8.4V	Revised date	A12

SET Model	Power P/N, Name
65UL3G	EAY65769211, FREE LGP65T-20U1

## Power Board Voltage / Current

MODEL	LGP65T-20U1
INPUT	100-240V~ 50/60Hz 2.5A
OUTPUT	13.2V --- 3.4A 272V --- 410mA

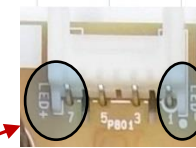

### Power Check Sequence

1. AC input Check : SK100 (100~240Vac)
2. PWR-ON Check : Check Hole
  - SET On : above 3V
  - SET St-by : 0V
3. 13.2V DC Check :
  - SET On : 13.2V
  - SET St-by : 7.8V

### 4. MS Level Check : Check Hole

MS Level	Range [V]	LED On/Off
MS (0V)	0 ~ 0.25	Off
MS (2V)	1.75 ~ 2.25	On (Home mode)
MS (3V)	2.75 ~ 3.25	On (Store Mode)

※ Home mode : General Customer  
Store mode : use Store

### 5. LED voltage Check : P801, Pin 1-7

Picture Condition : VIVID (Back light 100)
272V, 410mA

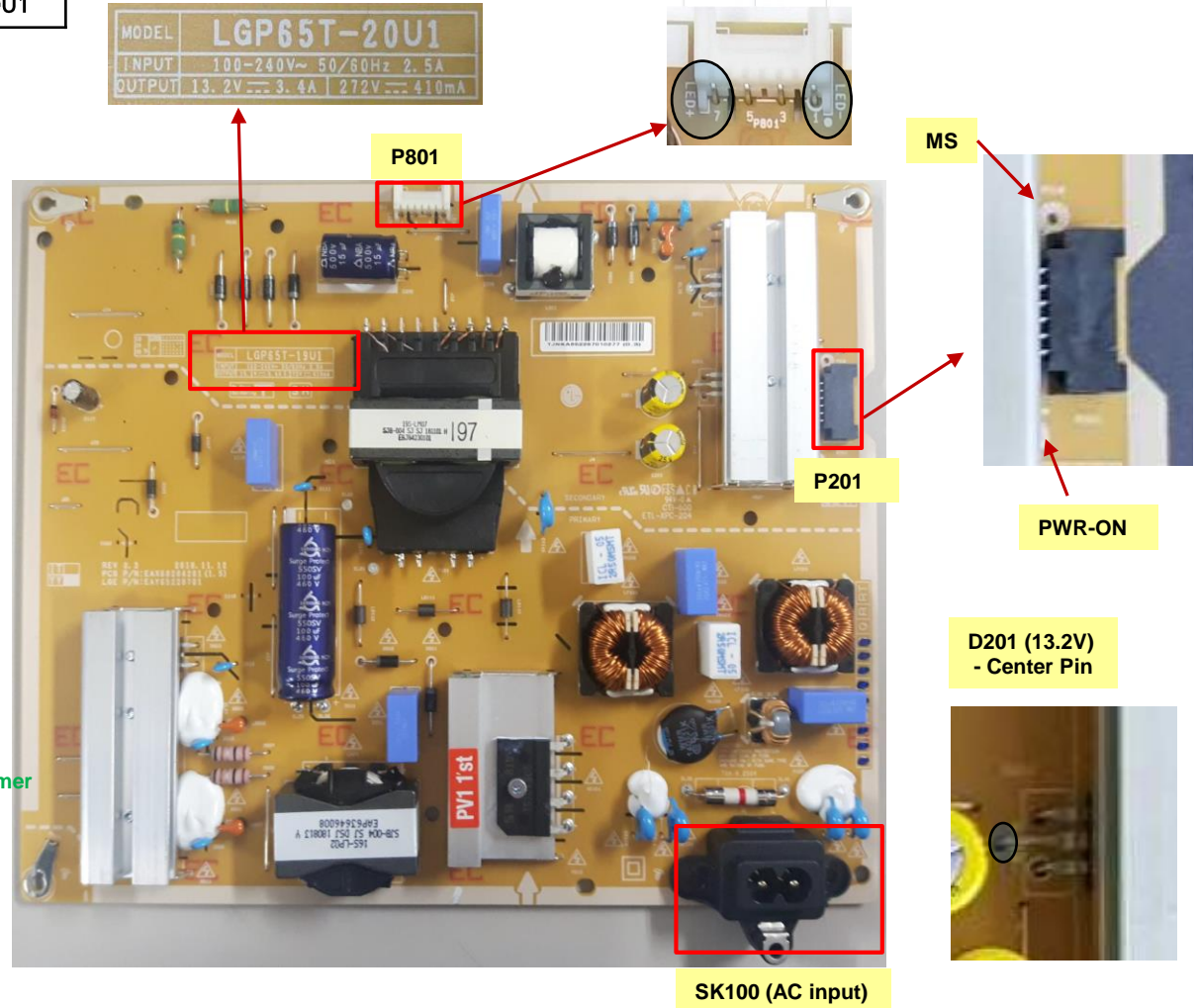

All condition meets, Power Board OK.

# Standard Repair Process Detail Technical Manual

	Error symptom	B. Power error _No power	Established date		
	Content	Check power input voltage and ST-BY 7.8V	Revised date		A13

SET Model	Power P/N, Name
75UL3G	EAY64908601 , LGP75T-18U1

## Power Check Sequence

1. AC input Check : SK100 (100~240Vac)
2. PWR-ON Check : PWR-ON
  - SET On : above 3V
  - SET St-by : 0V
3. 13.2V DC Check : D204 center Pin
  - SET On : 13.2V
  - SET St-by : 7.8V

## 4. MS Level Check : MS

MS Level	Range [V]	LED On/Off
MS (0V)	0 ~ 0.25	Off
MS (2V)	1.75 ~ 2.25	On (Home mode)
MS (3V)	2.75 ~ 3.25	On (Store Mode)

※ Home mode : General Customer  
Store mode : use Store

## 5. LED voltage Check : P801, Pin 1-7

Picture Condition : VIVID (Back light 100)	
Voltage	Current
204 V	420mA(399~441mA)
137 V	420mA(399~441mA)

all condition meets, Power Board OK.

## Power Board Voltage / Current

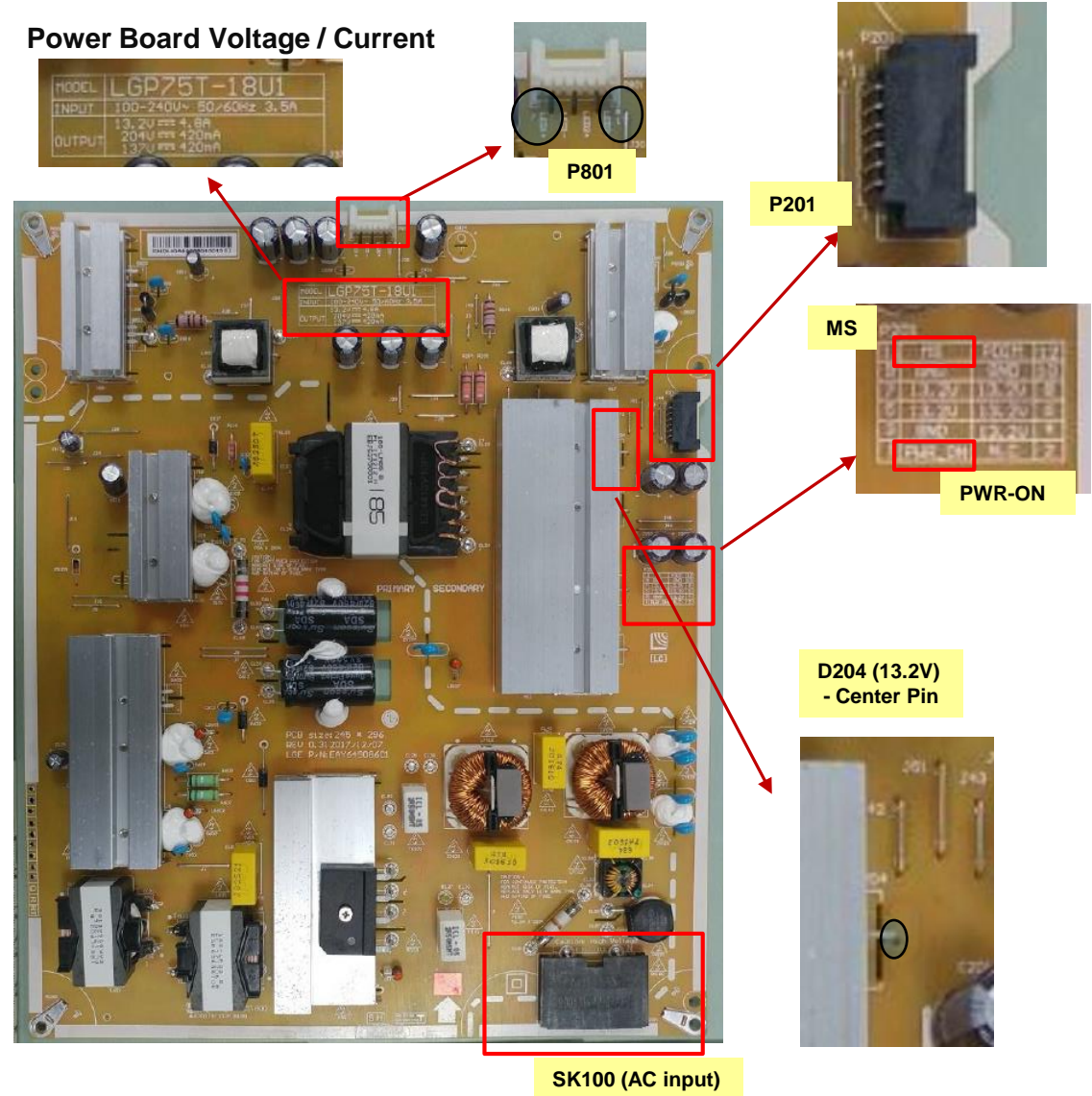

A13

# Standard Repair Process Detail Technical Manual

Monitor Signage	Error symptom	B. Power error _No power	Established date		
	Content	Check power input voltage and ST-BY 7.8V	Revised date		A14

SET Model	Power P/N, Name
86UL3G	EAY64888601, LGP86TJ-18U1

## Power Board Voltage / Current

MODEL	LGP86T-18U1
INPUT	100-240V~ 50/60Hz 4.5A
	13.2V --- 5.90A
OUTPUT	240V --- 410mA (LED+)
	240V --- 410mA (LED-)



### Power Check Sequence

1. AC input Check : SK101 (100~240Vac)
2. PWR-ON Check : J18
  - SET On : above 3V
  - SET St-by : 0V
3. 13.2V DC Check : J3
  - SET On : 13.2V [12.45V ~ 13.86V]
  - SET St-by : 7.8V

### 4. MS Level Check : MS

MS Level	Range [V]	LED On/Off
MS (0V)	0 ~ 0.25	Off
MS (2V)	1.75 ~ 2.25	On (Home mode)
MS (3V)	2.75 ~ 3.25	On (Store Mode)

※ Home mode : General Customer  
Store mode : use Store

### 5. LED voltage Check : P801, Pin 1-3,5-7

Picture Condition : VIVID (Back light 100)	
Voltage	Current (MS2)
240 V	410mA(393~434.8mA)
240 V	410mA(393~434.8mA)

all condition meets, Power Board OK.

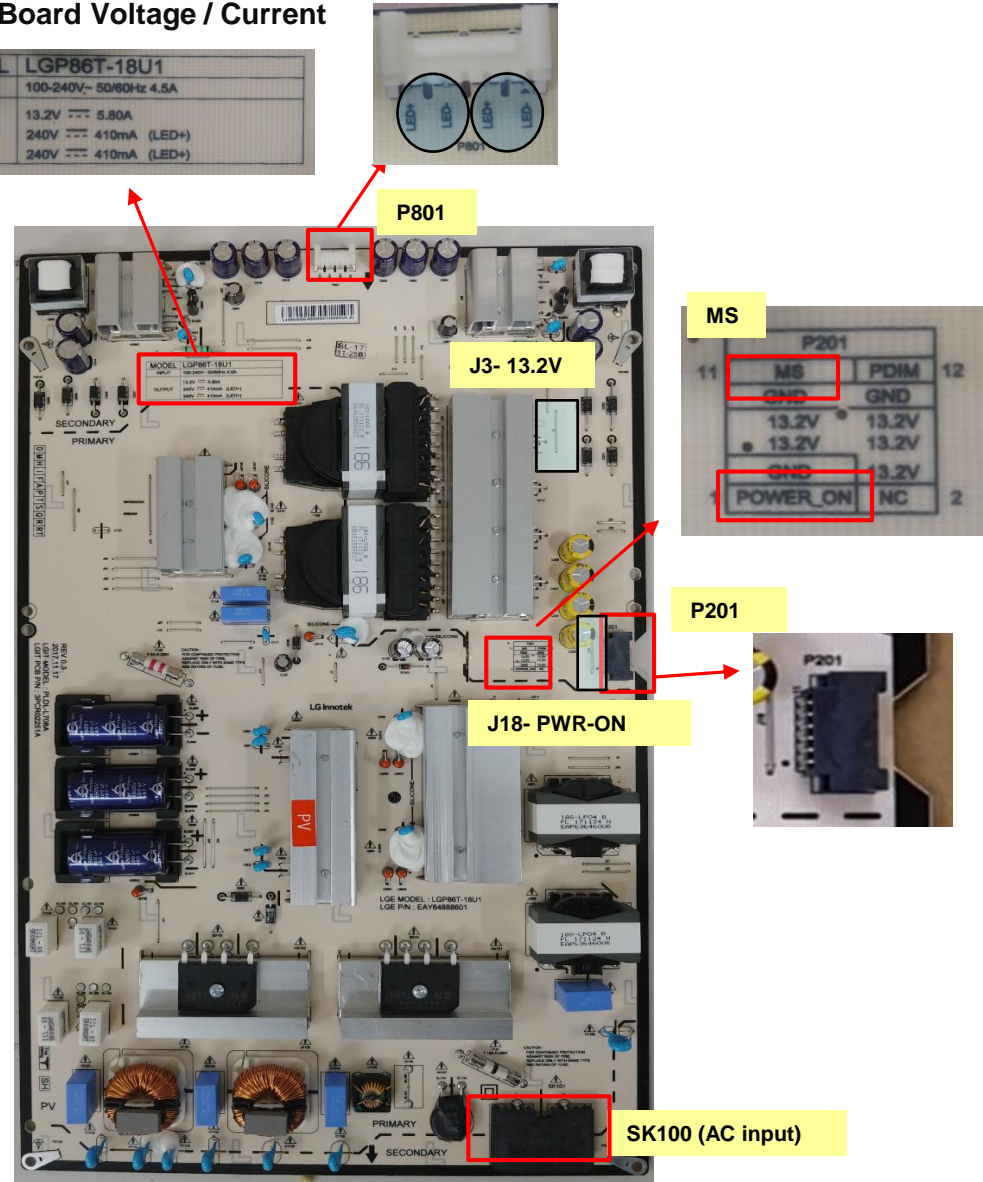

A14

# Standard Repair Process Detail Technical Manual

Monitor Signage	Error symptom	B. Power error _Off when on, off whiling viewing	Established date		
	Content	POWER OFF MODE checking method	Revised date		A15

<ALL MODELS>

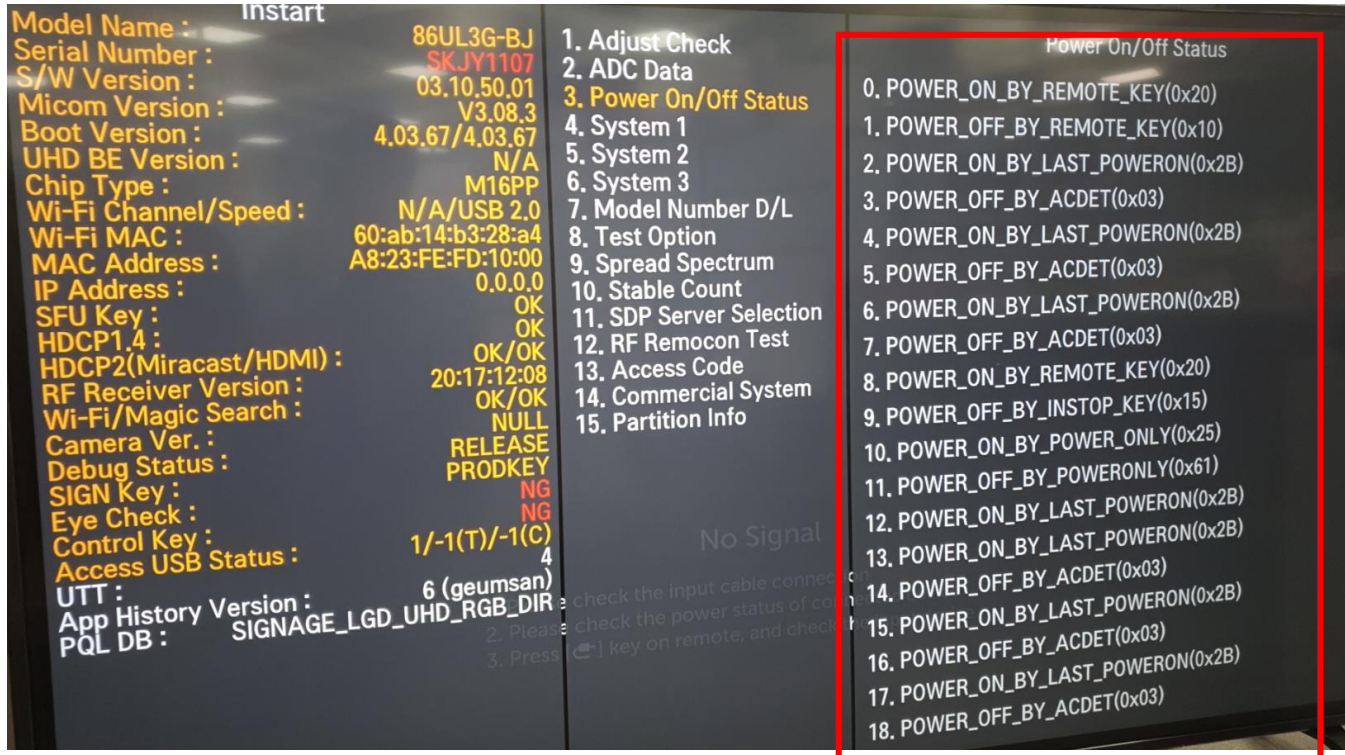

## Entry method

1. Press the IN-START button of the remote control for adjustment
2. Check the entry into adjustment item 3

# Standard Repair Process Detail Technical Manual

Monitor Signage	Error symptom	C. Audio error_No audio/Normal video	Established date		
	Content	Voltage and speaker checking method when there is no audio	Revised date		A16

<ALL MODELS>

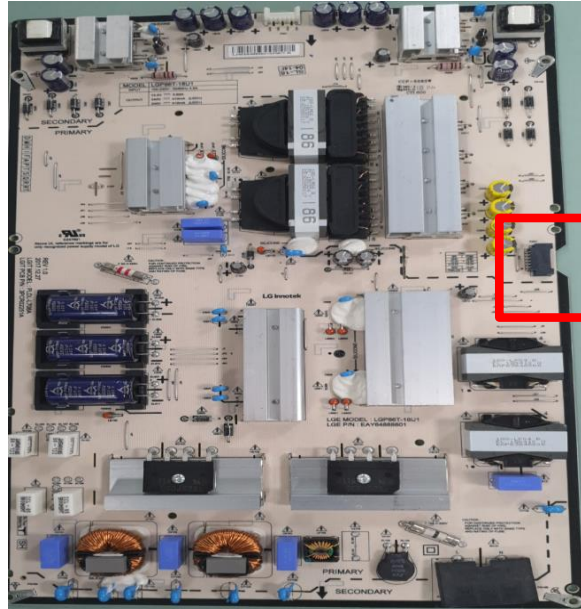

VSINC	SIN
GND	SCLK
Drv_ON	PDIM1
A-GND	A-GND
A13	A13
D13	D13
D-GND	D13
Pwr_ON	PDIM2
D-GND	D-GND

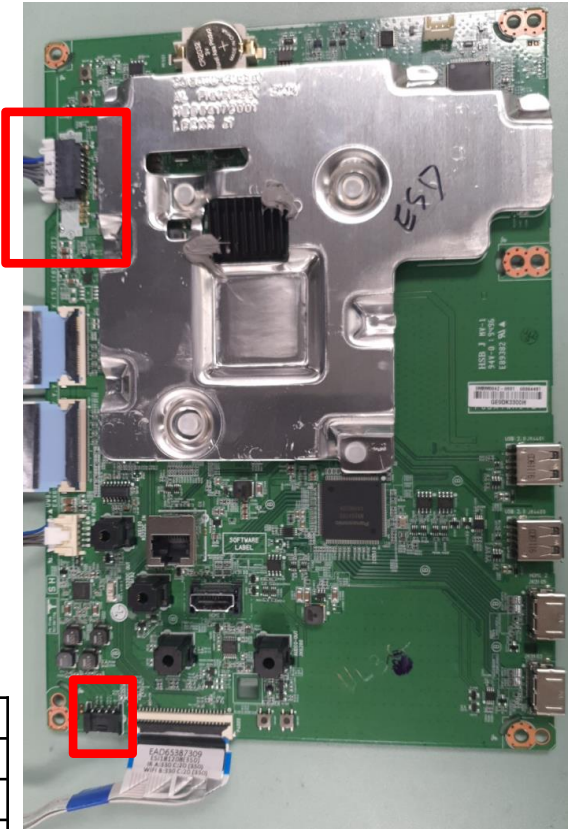

1	SPK_R-FT
2	SPK_R+FT
3	SPK_L-FT
4	SPK_L+FT

< Main Ass'y >

## Checking order when there is no audio

① Check the contact condition of or 13.2V connector of Main Board

② Measure the 13.2V input voltage supplied from Power Board  
(If there is no input voltage, remove and check the connector)

③ Connect the tester RX1 to the speaker terminal and if you hear the Chik Chik sound when you touch the GND and output terminal, the speaker is normal.

# Standard Repair Process Detail Technical Manual

Monitor Signage	Error symptom	D. Function error	Established date		
	Content	Remote control operation checking method	Revised date		A17

## ① IR & EYE Sensor

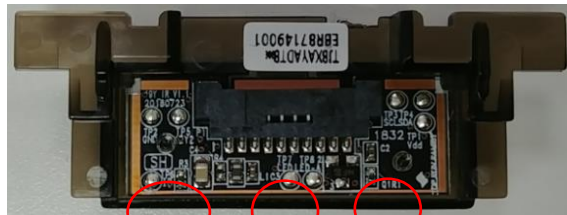

**IR LED Eye**

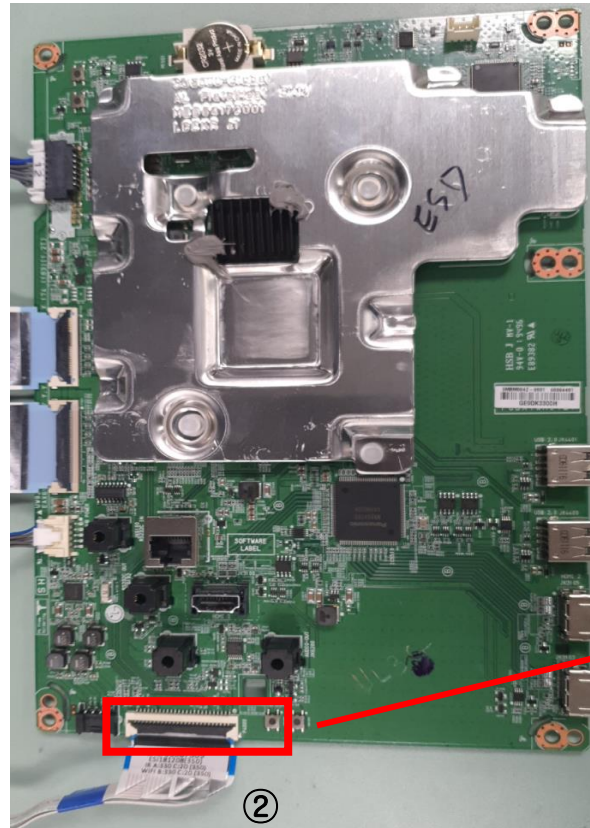

Checking order to check remote control

### Checking order

1. Check IR cable condition between IR & Main board. ( Check picture number ① and ②)
2. Check the standby 3.5V on the terminal 16 pin (③)
3. AS checking the Pre-Amp(IR LED light) , the power is in ON condition, an Analog Tester needle should move slowly, otherwise, it's defective.

Pin	Pin name
1	VCC
2	WIFI_DM
3	WIFI_DP
4	GND
5	WOL/WIFI_ON
6	VCC
7	WIFI_SUSPEND
8	GND
9	COMBO_RESET
10	BT_WAKEUP_HOST
11	GND
12	GND
13	
14	
15	
16	EYE_SDA
17	EYE_SCL
18	GND
19	IR
20	LED_R
21	GND
22	VCC
23	KEY2
24	KEY1
25	GND

# Standard Repair Process Detail Technical Manual

Monitor Signage	Error symptom	D. Function error_ No response in remote control, key error	Established date		
	Content	Remote control operation checking method	Revised date		A18

<ALL MODELS>

## ① Wifi & BT Front

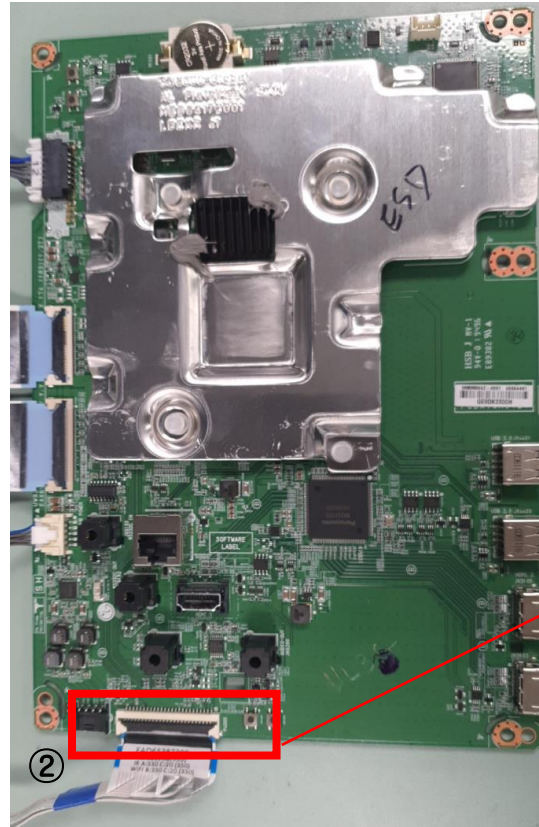

Pin	Pin name
1	+3.5V_WIFI
2	WIFI_DM_JACK
3	WIFI_DP_JACK
4	GND
5	WOL/WIFI_POWER_ON_JACK
6	+3.5V_WIFI
7	WIFI_SUSPEND/RESUME_JACK
8	GND
9	COMBO_RESET_JACK
10	BT_WAKEUP_HOST_JACK
11	GND
12	
13	NC
14	NC
15	NC
16	EYE_SDA_JACK
17	EYE_SCL_JACK
18	GND
19	IR_JACK
20	LED_R_JACK
21	GND
22	+3.5V_ST
23	KEY2_JACK
24	KEY1_JACK
25	GND

### Checking order

1. Check BT/Wifi cable condition between BT/Wifi assy & Main board.
2. Check the 3.5V on the terminal 22

