



LG

Life's Good

North/Latin America
Europe/Africa
Asia/Oceania

Internal Use Only

<http://aic.lgservice.com>
<http://eic.lgservice.com>
<http://biz.lgservice.com>

LED TV

SERVICE MANUAL

CHASSIS : LA42B

MODEL : 47LB6300 47LB6300-UQ

CAUTION

BEFORE SERVICING THE CHASSIS,
READ THE SAFETY PRECAUTIONS IN THIS MANUAL.

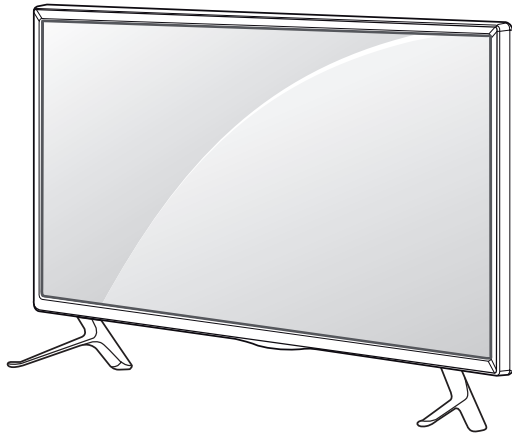

CONTENTS

CONTENTS	2
PRODUCT SAFETY	3
SPECIFICATION	4
ADJUSTMENT INSTRUCTION	13
EXPLODED VIEW	24
SCHEMATIC CIRCUIT DIAGRAM	

SAFETY PRECAUTIONS

IMPORTANT SAFETY NOTICE

Many electrical and mechanical parts in this chassis have special safety-related characteristics. These parts are identified by \triangle in the Schematic Diagram and Exploded View.

It is essential that these special safety parts should be replaced with the same components as recommended in this manual to prevent Shock, Fire, or other Hazards.

Do not modify the original design without permission of manufacturer.

General Guidance

An **isolation Transformer should always be used** during the servicing of a receiver whose chassis is not isolated from the AC power line. Use a transformer of adequate power rating as this protects the technician from accidents resulting in personal injury from electrical shocks.

It will also protect the receiver and its components from being damaged by accidental shorts of the circuitry that may be inadvertently introduced during the service operation.

If any fuse (or Fusible Resistor) in this TV receiver is blown, replace it with the specified.

When replacing a high wattage resistor (Oxide Metal Film Resistor, over 1 W), keep the resistor 10 mm away from PCB.

Keep wires away from high voltage or high temperature parts.

Before returning the receiver to the customer,

always perform an **AC leakage current check** on the exposed metallic parts of the cabinet, such as antennas, terminals, etc., to be sure the set is safe to operate without damage of electrical shock.

Leakage Current Cold Check(Antenna Cold Check)

With the instrument AC plug removed from AC source, connect an electrical jumper across the two AC plug prongs. Place the AC switch in the on position, connect one lead of ohm-meter to the AC plug prongs tied together and touch other ohm-meter lead in turn to each exposed metallic parts such as antenna terminals, phone jacks, etc.

If the exposed metallic part has a return path to the chassis, the measured resistance should be between 1 M Ω and 5.2 M Ω .

When the exposed metal has no return path to the chassis the reading must be infinite.

An other abnormality exists that must be corrected before the receiver is returned to the customer.

Leakage Current Hot Check (See below Figure)

Plug the AC cord directly into the AC outlet.

Do not use a line Isolation Transformer during this check.

Connect 1.5 K / 10 watt resistor in parallel with a 0.15 uF capacitor between a known good earth ground (Water Pipe, Conduit, etc.) and the exposed metallic parts.

Measure the AC voltage across the resistor using AC voltmeter with 1000 ohms/volt or more sensitivity.

Reverse plug the AC cord into the AC outlet and repeat AC voltage measurements for each exposed metallic part. Any voltage measured must not exceed 0.75 volt RMS which corresponds to 0.5 mA.

In case any measurement is out of the limits specified, there is possibility of shock hazard and the set must be checked and repaired before it is returned to the customer.

Leakage Current Hot Check circuit

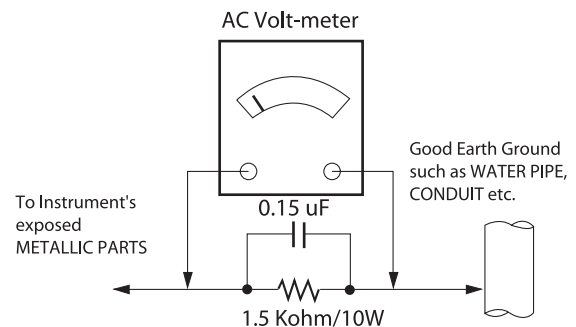

When 25A is impressed between Earth and 2nd Ground for 1 second, Resistance must be less than 0.1 Ω

*Base on Adjustment standard

SERVICING PRECAUTIONS

CAUTION: Before servicing receivers covered by this service manual and its supplements and addenda, read and follow the **SAFETY PRECAUTIONS** on page 3 of this publication.
NOTE: If unforeseen circumstances create conflict between the following servicing precautions and any of the safety precautions on page 3 of this publication, always follow the safety precautions. Remember: Safety First.

General Servicing Precautions

1. Always unplug the receiver AC power cord from the AC power source before;
 - a. Removing or reinstalling any component, circuit board module or any other receiver assembly.
 - b. Disconnecting or reconnecting any receiver electrical plug or other electrical connection.
 - c. Connecting a test substitute in parallel with an electrolytic capacitor in the receiver.
CAUTION: A wrong part substitution or incorrect polarity installation of electrolytic capacitors may result in an explosion hazard.
2. Test high voltage only by measuring it with an appropriate high voltage meter or other voltage measuring device (DVM, FETVOM, etc) equipped with a suitable high voltage probe. Do not test high voltage by "drawing an arc".
3. Do not spray chemicals on or near this receiver or any of its assemblies.
4. Unless specified otherwise in this service manual, clean electrical contacts only by applying the following mixture to the contacts with a pipe cleaner, cotton-tipped stick or comparable non-abrasive applicator; 10 % (by volume) Acetone and 90 % (by volume) isopropyl alcohol (90 % - 99 % strength)
CAUTION: This is a flammable mixture.
Unless specified otherwise in this service manual, lubrication of contacts is not required.
5. Do not defeat any plug/socket B+ voltage interlocks with which receivers covered by this service manual might be equipped.
6. Do not apply AC power to this instrument and/or any of its electrical assemblies unless all solid-state device heat sinks are correctly installed.
7. Always connect the test receiver ground lead to the receiver chassis ground before connecting the test receiver positive lead.
Always remove the test receiver ground lead last.
8. Use with this receiver only the test fixtures specified in this service manual.
CAUTION: Do not connect the test fixture ground strap to any heat sink in this receiver.

Electrostatically Sensitive (ES) Devices

Some semiconductor (solid-state) devices can be damaged easily by static electricity. Such components commonly are called Electrostatically Sensitive (ES) Devices. Examples of typical ES devices are integrated circuits and some field-effect transistors and semiconductor "chip" components. The following techniques should be used to help reduce the incidence of component damage caused by static by static electricity.

1. Immediately before handling any semiconductor component or semiconductor-equipped assembly, drain off any electrostatic charge on your body by touching a known earth ground. Alternatively, obtain and wear a commercially available discharging wrist strap device, which should be removed to prevent potential shock reasons prior to applying power to the unit under test.

2. After removing an electrical assembly equipped with ES devices, place the assembly on a conductive surface such as aluminum foil, to prevent electrostatic charge buildup or exposure of the assembly.
3. Use only a grounded-tip soldering iron to solder or unsolder ES devices.
4. Use only an anti-static type solder removal device. Some solder removal devices not classified as "anti-static" can generate electrical charges sufficient to damage ES devices.
5. Do not use freon-propelled chemicals. These can generate electrical charges sufficient to damage ES devices.
6. Do not remove a replacement ES device from its protective package until immediately before you are ready to install it. (Most replacement ES devices are packaged with leads electrically shorted together by conductive foam, aluminum foil or comparable conductive material).
7. Immediately before removing the protective material from the leads of a replacement ES device, touch the protective material to the chassis or circuit assembly into which the device will be installed.
CAUTION: Be sure no power is applied to the chassis or circuit, and observe all other safety precautions.
8. Minimize bodily motions when handling unpackaged replacement ES devices. (Otherwise harmless motion such as the brushing together of your clothes fabric or the lifting of your foot from a carpeted floor can generate static electricity sufficient to damage an ES device.)

General Soldering Guidelines

1. Use a grounded-tip, low-wattage soldering iron and appropriate tip size and shape that will maintain tip temperature within the range or 500 °F to 600 °F.
2. Use an appropriate gauge of RMA resin-core solder composed of 60 parts tin/40 parts lead.
3. Keep the soldering iron tip clean and well tinned.
4. Thoroughly clean the surfaces to be soldered. Use a small wire-bristle (0.5 inch, or 1.25 cm) brush with a metal handle. Do not use freon-propelled spray-on cleaners.
5. Use the following unsoldering technique
 - a. Allow the soldering iron tip to reach normal temperature. (500 °F to 600 °F)
 - b. Heat the component lead until the solder melts.
 - c. Quickly draw the melted solder with an anti-static, suction-type solder removal device or with solder braid.
CAUTION: Work quickly to avoid overheating the circuit board printed foil.
6. Use the following soldering technique.
 - a. Allow the soldering iron tip to reach a normal temperature (500 °F to 600 °F)
 - b. First, hold the soldering iron tip and solder the strand against the component lead until the solder melts.
 - c. Quickly move the soldering iron tip to the junction of the component lead and the printed circuit foil, and hold it there only until the solder flows onto and around both the component lead and the foil.
CAUTION: Work quickly to avoid overheating the circuit board printed foil.
 - d. Closely inspect the solder area and remove any excess or splashed solder with a small wire-bristle brush.

IC Remove/Replacement

Some chassis circuit boards have slotted holes (oblong) through which the IC leads are inserted and then bent flat against the circuit foil. When holes are the slotted type, the following technique should be used to remove and replace the IC. When working with boards using the familiar round hole, use the standard technique as outlined in paragraphs 5 and 6 above.

Removal

1. Desolder and straighten each IC lead in one operation by gently prying up on the lead with the soldering iron tip as the solder melts.
2. Draw away the melted solder with an anti-static suction-type solder removal device (or with solder braid) before removing the IC.

Replacement

1. Carefully insert the replacement IC in the circuit board.
2. Carefully bend each IC lead against the circuit foil pad and solder it.
3. Clean the soldered areas with a small wire-bristle brush. (It is not necessary to reapply acrylic coating to the areas).

"Small-Signal" Discrete Transistor Removal/Replacement

1. Remove the defective transistor by clipping its leads as close as possible to the component body.
2. Bend into a "U" shape the end of each of three leads remaining on the circuit board.
3. Bend into a "U" shape the replacement transistor leads.
4. Connect the replacement transistor leads to the corresponding leads extending from the circuit board and crimp the "U" with long nose pliers to insure metal to metal contact then solder each connection.

Power Output, Transistor Device

Removal/Replacement

1. Heat and remove all solder from around the transistor leads.
2. Remove the heat sink mounting screw (if so equipped).
3. Carefully remove the transistor from the heat sink of the circuit board.
4. Insert new transistor in the circuit board.
5. Solder each transistor lead, and clip off excess lead.
6. Replace heat sink.

Diode Removal/Replacement

1. Remove defective diode by clipping its leads as close as possible to diode body.
2. Bend the two remaining leads perpendicular y to the circuit board.
3. Observing diode polarity, wrap each lead of the new diode around the corresponding lead on the circuit board.
4. Securely crimp each connection and solder it.
5. Inspect (on the circuit board copper side) the solder joints of the two "original" leads. If they are not shiny, reheat them and if necessary, apply additional solder.

Fuse and Conventional Resistor

Removal/Replacement

1. Clip each fuse or resistor lead at top of the circuit board hollow stake.
2. Securely crimp the leads of replacement component around notch at stake top.

3. Solder the connections.

CAUTION: Maintain original spacing between the replaced component and adjacent components and the circuit board to prevent excessive component temperatures.

Circuit Board Foil Repair

Excessive heat applied to the copper foil of any printed circuit board will weaken the adhesive that bonds the foil to the circuit board causing the foil to separate from or "lift-off" the board. The following guidelines and procedures should be followed whenever this condition is encountered.

At IC Connections

To repair a defective copper pattern at IC connections use the following procedure to install a jumper wire on the copper pattern side of the circuit board. (Use this technique only on IC connections).

1. Carefully remove the damaged copper pattern with a sharp knife. (Remove only as much copper as absolutely necessary).
2. Carefully scratch away the solder resist and acrylic coating (if used) from the end of the remaining copper pattern.
3. Bend a small "U" in one end of a small gauge jumper wire and carefully crimp it around the IC pin. Solder the IC connection.
4. Route the jumper wire along the path of the out-away copper pattern and let it overlap the previously scraped end of the good copper pattern. Solder the overlapped area and clip off any excess jumper wire.

At Other Connections

Use the following technique to repair the defective copper pattern at connections other than IC Pins. This technique involves the installation of a jumper wire on the component side of the circuit board.

1. Remove the defective copper pattern with a sharp knife. Remove at least 1/4 inch of copper, to ensure that a hazardous condition will not exist if the jumper wire opens.
2. Trace along the copper pattern from both sides of the pattern break and locate the nearest component that is directly connected to the affected copper pattern.
3. Connect insulated 20-gauge jumper wire from the lead of the nearest component on one side of the pattern break to the lead of the nearest component on the other side. Carefully crimp and solder the connections.

CAUTION: Be sure the insulated jumper wire is dressed so the it does not touch components or sharp edges.

SPECIFICATION

NOTE : Specifications and others are subject to change without notice for improvement.

1. Application range

- 1) This spec sheet is applied all of the 32", 42", 47", 50", 55", 60", 65", 70" LED TV with LA42A/B chassis.
- 2) Not included spec and each product spec in this spec sheet apply correspondingly to the following each country standard and requirement of Buyer

2. Test condition

Each part is tested as below without special notice.

- 1) Temperature : 20 °C ± 5 °C
- 2) Relative Humidity: 65 % ± 10 %
- 3) Power Voltage

Market	Input voltage	Frequency	Remark
USA	110~240V	50/60Hz	Standard Voltage of each product is marked by models

- 4) Specification and performance of each parts are followed each drawing and specification by part number in accordance with BOM
- 5) The receiver must be operated for about 20 minutes prior to the adjustment

3. Test method

- 1) Performance: LGE TV test method followed
- 2) Demanded other specification
 - Safety : UL, CSA, CE, IEC specification
 - EMC: FCC, ICES, CE, IEC specification
 - Wireless : Wireless HD Specification (Option)

4. General Specification

No	Item	Specification			Remark
1	Receiving System	ATSC / NTSC-M / 64 QAM / 256 QAM			
2	Available Channel	1) VHF : 02~13 2) UHF : 14~69 3) DTV : 02-69 4) CATV : 01~135 5) CADTV : 01~135			
3	Input Voltage	1AC 100 ~ 240V@ 50/60Hz			AC 120V, 50/60Hz on the label (USA)
4	Input Voltage	AC 220 - 240V ~ 60Hz			
5	Aspect Ratio	16:9			
6	Tuning System	FS			
7	LCD Module	LC550DUH-PGF1 FHD 55.0INCH 1920X1080 450CD COLOR 72% 16/9 1300:1 120Hz Inverter N LED 3D(FPR) W/O T-con, 72.4W, 8bit, 10000K, 178/178 8ms LG Display Co., Ltd.	LGD	LC550DUH-PGF1	55LB7200-UB
		LC550EUH-LGF1 FHD 55.0INCH 1920X1080 450CD COLOR 72% 16/9 1300:1 120Hz Inverter N LED 3D(FPR) 68.1W, 8Bit, 10000K, 178/178, 8ms LG Display Co., Ltd.	LGD		55LB8700-UA
		HC700CUF-VHHD1 FHD 70INCH 1920X1080 400CD COLOR 72% 16/9 5000:1 120Hz - - - TBD HEESUNG ELEC- TRONICS LTD.	Sharp	HC700CUF-VHHD1 HC700CUF-VHHD2	70LB7100-UC
		LC600DUF-FGF1 FHD 60INCH 1920X1080 450CD COLOR 68% 16/9 1600:1 240Hz(T) Inverter N LED 3D(FPR) W/T-con 83.2W 8Bit 10000k 178/178 6ms(GTG)_HS_PJ(Dark Titan) LG Display Co., Ltd.	LGD	LC600DUF-FGF1	60LB7100-UT
		LC420DUH-FGP1 FHD 42.0INCH 1920X1080 300CD COLOR 68% 16/9 1600:1 120Hz Inverter N LED 3D(FPR) W.O/T-con 41W 8Bit 10000k 178/178 6ms(GTG)_nOTS LG Display Co., Ltd.	LGD	LC420DUH-FGP1	42LB6500-UM
		T420HVJ01.0 FHD 42INCH 1920X1080 300CD COLOR 72% 16/9 3000:1 - - - - TBD AU OPTRONICS CORP	AUO	T420HVJ01.1	42LB6500-UM
		LC470DUH-FGP1 FHD 47INCH 1920X1080 300CD COLOR 68% 16/9 1600:1 120Hz Inverter N LED 3D(FPR) W.O/T-con 50.8W 8Bit 10000k 178/178 6ms(GTG)_nOTS LG Display Co., Ltd.	LGD	LC470DUH-FGP1	47LB6500-UM
		LC550DUH-FGA2 FHD 55.0INCH 1920X1080 300CD COLOR 68% 16/9 1600:1 120Hz Inverter N LED 2D W.O/T-con 64.2W 8Bit 10000k 178/178 6ms(GTG)_HS(Light Silver) LG Display Co., Ltd.	LGD	LC550DUH-FGA2	55LB6300-UQ

No	Item	Specification			Remark
		LC550DUH-FGP1 FHD 55.0INCH 1920X1080 330CD COLOR 68% 16/9 1600:1 120Hz Inverter N LED 3D(FPR) W.O/T-con 64.2W 8Bit 10000k 178/178 6ms(GTG)_HS LG Display Co., Ltd.	LGD	LC550DUH-FGP1	55LB6500-UM
		LC650DUF-FGF1 FHD 65INCH 1920X1080 450CD COLOR 68% 16/9 1600:1 240Hz(T) Inverter N LED 3D(FPR) W/T-con 117.2W 8Bit 10000k 178/178 6ms(GTG)_HS_PJ(Dark Titan) LG Display Co., Ltd.	LGD	LC650DUF-FGF1	65LB7100-UC, 65LB7100-UB
		LC600DUF-FGP1 FHD 60INCH 1920X1080 350CD COLOR 68% 16/9 1600:1 120Hz Inverter N LED 3D(FPR) W/T-con 72.7W 8Bit 10000k 178/178 9ms(GTG) LVDS 2 Port (HS) LG Display Co., Ltd.	LGD	LC600DUF-FGP1	60LB6500-UP
		LC470DUH-FGA2 FHD 47INCH 1920X1080 300CD COLOR 68% 16/9 1600:1 120Hz Inverter N LED 2D W/T-con 50.8W 8Bit 10000k 178/178 6ms(GTG)_ nOTS(Light Silver) LG Display Co., Ltd.	LGD	LC470DUH-FGA2	47LB6300-UQ
		LC500DUH-FGP1 FHD 50INCH 1920X1080 300CD COLOR 68% 16/9 1600:1 120Hz Inverter N LED 3D(FPR) W.O/T-con 55.4W 8Bit 10000k 178/178 6ms(GTG)_nOTS LG Display Co., Ltd.	LGD	LC500DUH-FGP1	50LB6500-UM
		LC420DUH-FGA2 FHD 42.0INCH 1920X1080 300CD COLOR 68% 16/9 1600:1 120Hz Inverter N LED 2D W/T-con 41W 8Bit 10000k 178/178 6ms(GTG)_ nOTS(Light Silver) LG Display Co., Ltd.	LGD	LC420DUH-FGA2	42LB6300-UQ
10	Operating Environ- ment	1) Temp : 0 ~ 40 deg 2) Humidity : ~ 80 %			
11	Storage Environ- ment	1) Temp : -20 ~ 60 deg 2) Humidity : ~ 85 %			

5. Supported video resolutions

5.1. Component 2D input(Y, CB/PB, CR/PR)

No.	Resolution	H-freq(kHz)	V-freq.(kHz)	Pixel clock	Proposed
1.	720*480	15.73	60	13.5135	SDTV ,DVD 480I
2.	720*480	15.73	59.94	13.5	SDTV ,DVD 480I
3.	720*480	31.50	60	27.027	SDTV 480P
4.	720*480	31.47	59.94	27.0	SDTV 480P
5.	1280*720	45.00	60.00	74.25	HDTV 720P
6.	1280*720	44.96	59.94	74.176	HDTV 720P
7.	1920*1080	33.75	60.00	74.25	HDTV 1080I
8.	1920*1080	33.72	59.94	74.176	HDTV 1080I
9.	1920*1080	67.50	60	148.50	HDTV 1080P
10.	1920*1080	67.432	59.94	148.352	HDTV 1080P

5.2. Component 3D input(Y, CB/PB, CR/PR)

No.	Resolution	H-freq(kHz)	V-freq.(kHz)	Pixel clock	3D input proposed mode	Proposed
1.	1280*720	45.00	60.00	74.25	2D to 3D,Side by Side, Top and Bottom	HDTV 720P
2.	1280*720	44.96	59.94	74.176	2D to 3D,Side by Side, Top and Bottom	HDTV 720P
3.	1920*1080	33.75	60.00	74.25	2D to 3D,Side by Side, Top and Bottom	HDTV 1080I
4.	1920*1080	33.72	59.94	74.176	2D to 3D,Side by Side, Top and Bottom	HDTV 1080I

5.3. HDMI Input (PC/DTV)

No	Resolution	H-freq(kHz)	V-freq.(Hz)	Pixel clock(MHz)	Proposed	
PC						
1	640*350	31.468	70.09	25.17	EGA	X
2.	720*400	31.469	70.08	28.32	DOS	O
3.	640*480	31.469	59.94	25.17	VESA(VGA)	O
4	800*600	37.879	60.31	40.00	VESA(SVGA)	O
5	1024*768	48.363	60.00	65.00	VESA(XGA)	O
6	1152*864	54.348	60.053	80.002	VESA	O
7	1360*768	47.712	60.015	85.50	VESA (WXGA)	X
8	1280*1024	63.981	60.020	108.00	VESA (SXGA)	O
9	1920*1080	67.5	60	148.5	HDTV 1080P	O
DTV						
1	720*480	31.50	60	27.027	SDTV 480P	
2	720*480	31.469	59.94	27.00	SDTV 480P	
3	1280*720	45.00	60.00	74.25	HDTV 720P	
4	1280*720	44.96	59.94	74.176	HDTV 720P	
5	1920*1080	33.75	60.00	74.25	HDTV 1080I	
6	1920*1080	33.72	59.94	74.176	HDTV 1080I	
7	1920*1080	67.500	60	148.50	HDTV 1080P	
8	1920*1080	67.43	59.94	148.352	HDTV 1080P	
9	1920*1080	27.000	24.000	74.25	HDTV 1080P	
10	1920*1080	26.97	23.97	74.176	HDTV 1080P	
11	1920*1080	33.75	30.000	74.25	HDTV 1080P	
12	1920*1080	33.716	29.976	74.176	HDTV 1080P	

5.4. 3D HDMI Input(1.4b)

No	Resolution	H-freq(kHz)	V-freq.(Hz)	Pixel clock(MHz)	3D input proposed mode
1.	720*480p	63	59.94 / 60	54.00	F/P,L/A
		31.5		27.00	T/B,S/S,S/S Full
2.	1280*720p	90.00	59.94 / 60	148.5	F/P, L/A
		44.96 / 45		74.17/74.25	S/S, T&B, S/S Full
3.	1920*1080i	67.432 / 67.5	59.94 / 60	148.35/148.5	F/P, F/A
		33.75		74.25	S/S, T&B, S/S Full
4.	1920*1080p	54	23.976 / 24	148.5	F/P, L/A
		26.973 / 27	23.976 / 24	74.175/74.25	S/S, T&B, S/S Full
5.	1920*1080p	33.716 / 33.75	29.97 / 30.00	74.175/74.25	S/S, T&B, S/S Full
		67.50	30.00	148.5	F/P, L/A
			60.00		S/S, T&B

5.5. 3D HDMI-PC Input

No.	Resolution	H-freq(kHz)	V-freq.(Hz)	Pixel clock(MHz)	3D input proposed mode
1.	1024*768	48.363	60.004	65.000	2D to 3D, S/S, T&B
2.	1360*768	47.712	60.015	85.500	
3.	1920*1080	67.50	60.00	148.50	2D to 3D, S/S, T&B, C/B, R/I, C/I

5.6. HDMI Input(1.3)

No	Resolution	H-freq(kHz)	V-freq.(Hz)	Pixel clock(MHz)	3D input proposed mode
1.	720*480p	63	59.94 / 60	54.00	2D to 3D, S/S, T&B, C/B, R/I, C/I
		31.5		27.00	
2.	1280*720p	90.00	59.94 / 60	148.5	
		44.96 / 45		74.17/74.25	
3.	1920*1080i	67.432 / 67.5	59.94 / 60	148.35/148.5	2D to 3D, S/S, T&B
		33.75		74.25	
4.	1920*1080p	54	23.976 / 24	148.5	2D to 3D, S/S, T&B, C/B, R/I, C/I
		26.973 / 27	23.976 / 24	74.175/74.25	
5.	1920*1080p	33.716 / 33.75	29.97 / 30.00	74.175/74.25	

5.7. USB/DLNA Input

5.7.1. 3D Auto detection

No.	Resolution	H-freq(kHz)	V-freq.(kHz)	Pixel clock(MHz)	3D input proposed mode	Proposed
1	1920*1080	33.75	30.000	74.25	Side-by-side, Top-and-Bottom Checkerboard, Row Interleaving, Column Interleaving, Frame Sequential (Photo : Side-by-side, Top-and-Bottom)	HDTV 1080P

5.7.2. 3D Manual(Movie)

No.	Resolution	H-freq(kHz)	V-freq.(kHz)	3D input proposed mode
1	Under 704*480	-	-	2D to 3D
2	Over 704*480i			2D to 3D,Side-by-side , Top-and-Bottom
3	Over 704*480p		50/60	2D to 3D,Side-by-side , Top-and-Bottom Checkerboard, Row Interleaving, Column Interleaving, Frame Sequential
4	Over 704*480p		Others	2D to 3D,Side-by-side , Top-and-Bottom Checkerboard, Row Interleaving, Column Interleaving

5.7.3. 3D Manual(Photo)

No.	Resolution	H-freq(kHz)	V-freq.(kHz)	3D input proposed mode
1	Under 320*240	-	-	2D to 3D
2	Over 320*240			2D to 3D,Side-by-side , Top-and-Bottom

5.8. Miracast/Widi Input

5.8.1. 3D Manual







No.	Resolution	H-freq(kHz)	V-freq.(kHz)	3D input proposed mode
1	1024*768p	-	30/60	2D to 3D, Side-by-side , Top-and-Bottom
2	1280*720p			
3	1920*1080p			
4	Others		-	2D to 3D

5.8.2. RF 3D Input(DTV)

No.	Resolution	H-freq(kHz)	V-freq.(Hz)	Pixel clock(MHz)	Proposed	3D input proposed mode
1	1280*720	45.000	60	74.25	HDTV 720P	2D to 3D, Side by Side, Top & Bottom
2	1920*1080	33.75	60	74.25	HDTV 1080I	2D to 3D, Side by Side, Top & Bottom

5.9. 2D to 3D Conversion(RF 3D Input(DTV))

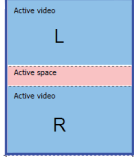
No	INPUT	Freq	Resolution
1	Digital TV / Analog TV	2D Support freq	2D Support resolution
2	HDMI	2D Support freq	2D Support resolution
3	Component	2D Support freq	2D Support resolution
4	Composite	2D Support freq	2D Support resolution
5	USB	2D Support freq	2D Support resolution

No	Side by Side	Top & Bottom	Checkerboard	Single Frame Sequential	Frame Packing	2D to 3D
1						

ADJUSTMENT INSTRUCTION

1. Application

This spec. sheet applies to LA42B Chassis applied LED TV all models manufactured in TV factory

2. Specification

- (1) Because this is not a hot chassis, it is not necessary to use an isolation transformer. However, the use of isolation transformer will help protect test instrument.
- (2) Adjustment must be done in the correct order.
- (3) The adjustment must be performed in the circumstance of 25 ±5 °C of temperature and 65±10% of relative humidity if there is no specific designation
- (4) The input voltage of the receiver must keep 100~240V, 50/60Hz
- (5) At first Worker must turn on the SET by using Power Only key.
- (6) The receiver must be operated for about 5 minutes prior to the adjustment when module is in the circumstance of over 15 °C
In case of keeping module is in the circumstance of 0°C, it should be placed in the circumstance of above 15°C for 2 hours
In case of keeping module is in the circumstance of below -20°C, it should be placed in the circumstance of above 15°C for 3 hours.

※ Caution

When still image is displayed for a period of 20 minutes or longer (especially where W/B scale is strong. Digital pattern 13ch and/or Cross hatch pattern 09ch), there can some afterimage in the black level area

3. Adjustment items

3.1. Main PCBA Adjustments

- (1) ADC adjustment : ADC adjustment is OTP (Auto ADC)
- (2) EDID download : HDMI

3.2. Final assembly adjustment

- (1) White Balance adjustment
- (2) RS-232C functionality check
- (3) Factory Option setting per destination
- (4) Shipment mode setting (In-Stop)
- (5) GND and HI-POT test

3.3. Appendix

- (1) Tool option menu, USB Download (S/W Update, Option and Service only)
- (2) Manual adjustment for ADC calibration and White balance.
- (3) Shipment conditions, Channel pre-set

4. MAIN PCBA Adjustments

4.1. ADC Calibration

- An ADC calibration is not necessary because MAIN SoC (LGExxxx) is already calibrated from IC Maker
- If it needs to adjust manually, refer to appendix.

4.2. MAC Address, ESN Key and Widevine Key download

4.2.1. Equipment & Condition

- 1) Play file: keydownload.exe

4.2.2. Communication Port connection

- 1) Key Write: Com 1,2,3,4 and 115200 (Baudrate)
- 2) Barcode: Com 1,2,3,4 and 9600 (Baudrate)

4.2.3. Download process

- 1) Select the download items.
- 2) Mode check: Online Only
- 3) Check the test process
 - US, Canada models: DETECT -> MAC_WRITE -> WIDEVINE_WRITE
 - Korea, Mexico models: DETECT -> MAC_WRITE -> WIDEVINE_WRITE
- 4) Play : START
- 5) Check of result: Ready, Test, OK or NG

4.2.4. Communication Port connection

- 1) Connect: PCBA Jig -> RS-232C Port == PC -> RS-232C Port

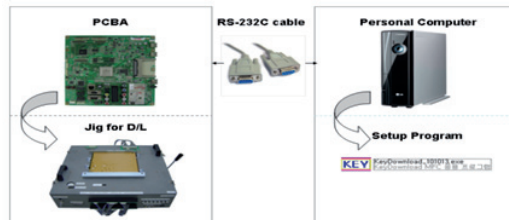

4.2.5. Download

- 1) US, Canada models (14Y LCD TV + MAC + Widevine + ESN Key + DTCP Key + HDCP1.4 and HDCP2.0)

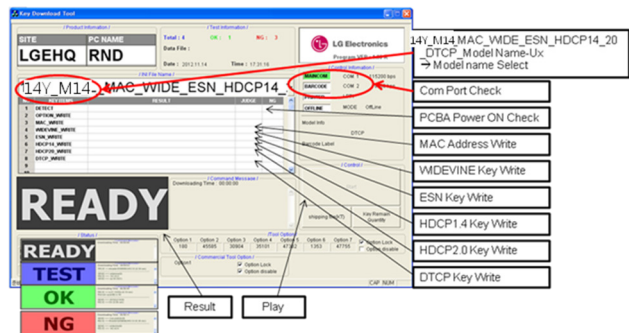

4.2.6. Inspection

- In INSTART menu, check these keys.

4.3. LAN port Inspection (Ping Test)

4.3.1. Equipment setting

- 1) Play the LAN Port Test PROGRAM.
- 2) Input IP set up for an inspection to Test Program.
- IP number: 12.12.2.2

Connect: SET-> LAN Port == PC-> LAN Port



4.3.2. LAN PORT inspection (PING TEST)

- 1) Play the LAN Port Test Program.
- 2) Connect each other LAN Port Jack.
- 3) Play Test (F9) button and confirm OK Message.
- 4) Remove LAN CABLE

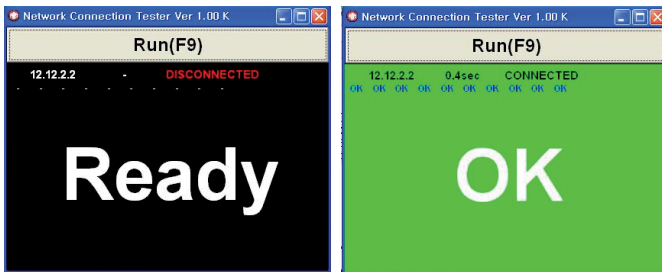

Step 1)

Step 3) Check 'OK' Signal

4.4. EDID Download

4.4.1 Overview

- It is a VESA regulation. A PC or a MNT will display an optimal resolution through information sharing without any necessity of user input. It is a realization of "Plug and Play".

4.4.2 Equipment

- Since embedded EDID data is used, EDID download JIG, HDMI cable and D-sub cable are not need.
- Adjust remocon

4.4.3. EDID DATA

4.4.3.1. 2D_8bit_PCM(US)_xvYCC : off

HDMI EDID 2D_8bit_PCM(US)_xvYCC : off

	0x00	0x01	0x02	0x03	0x04	0x05	0x06	0x07	0x08	0x09	0x0A	0x0B	0x0C	0x0D	0x0E	0x0F
0x00	00	FF	FF	FF	FF	FF	FF	00	1E	6D	Ⓣ		Ⓣ			
0x01	Ⓣ		01	03	80	A0	5A	78	0A	EE	91	A3	54	4C	99	28
0x02	0F	50	54	A1	08	00	31	40	45	40	61	40	71	40	81	80
0x03	01	01	01	01	01	01	02	3A	80	18	71	38	2D	40	58	2C
0x04	45	00	40	84	63	00	00	1E	66	21	50	B0	51	00	1B	30
0x05	40	70	36	00	40	84	63	00	00	1E	00	00	00	FD	00	3A
0x06	3E	1E	53	10	00	0A	20	20	20	20	Ⓣ		Ⓣ			
0x07	Ⓣ														01	Ⓣ1
0x08	02	03	1D	F1	48	90	22	20	05	04	03	02	01	23	09	57
0x09	07	Ⓣ		Ⓣ						E3	05	00	00	02	3A	80
0x0A	18	71	38	2D	40	58	2C	04	05	A0	5A	00	00	00	1E	01
0x0B	1D	80	18	71	1C	16	20	58	2C	25	00	40	84	63	00	00
0x0C	9E	01	1D	00	72	51	D0	1E	20	6E	28	55	00	40	84	63
0x0D	00	00	1E	8C	0A	D0	8A	20	E0	2D	10	10	3E	96	00	40
0x0E	84	63	00	00	18	00	00	00	00	00	00	00	00	00	00	00
0x0F	00	00	00	00	00	00	00	00	00	00	00	00	00	00	00	Ⓣ2

•Reference

- HDMI1 ~ HDMI3
- In the data of EDID, bellows may be different by S/W or Input mode.

ⓐ Product ID

HEX	EDID Table	DDC Function
0001	0100	Analog
0001	0100	Digital

ⓑ Serial No: Controlled on production line.

ⓒ Month, Year: Controlled on production line:

- ex) Monthly : '01' -> '01'
- Year : '2014' -> '18'

ⓓ Model Name(Hex): LGTV

Chassis	MODEL NAME(HEX)
LA42B	00 00 00 FC 00 4C 47 20 54 56 0A 20 20 20 20 20 20

ⓔ Checksum(LG TV): Changeable by total EDID data.

	Ⓣ1	Ⓣ2	Ⓣ3
HDMI1	E7	49	X
HDMI2	E7	39	X
HDMI3	E7	29	X

ⓕ Vendor Specific(HDMI)

INPUT	MODEL NAME(HEX)
HDMI1	67 03 0C 00 10 00 80 1E
HDMI2	67 03 0C 00 20 00 80 1E
HDMI3	67 03 0C 00 30 00 80 1E

4.4.3.2. 2D_10bit_PCM(US)_xvYCC : off

HDMI EDID 2D_10bit_PCM(US)_xvYCC : off

0x00	00	FF	FF	FF	FF	FF	FF	00	1E	6D	Ⓣ				Ⓣ												
0x01	Ⓣ	01	03	80	A0	5A	78	0A	EE	91	A3	54	4C	99	26												
0x02	0F	50	54	A1	08	00	31	40	45	40	61	40	71	40	81	80											
0x03	01	01	01	01	01	01	02	3A	80	18	71	38	2D	40	58	2C											
0x04	45	00	A0	5A	00	00	00	1E	66	21	50	B0	51	00	1B	30											
0x05	40	70	36	00	A0	5A	00	00	00	1E	00	00	00	FD	00	3A											
0x06	3E	1E	53	10	00	0A	20	20	20	20	20	Ⓣ															
0x07	Ⓣ															01	Ⓣ1										
0x00	02	03	1D	F1	48	90	22	20	05	04	03	02	01	23	09	57											
0x01	07	Ⓣ															E3	05	00	00	02	3A	80				
0x02	18	71	38	2D	40	58	2C	04	05	A0	5A	00	00	00	1E	01											
0x03	1D	80	18	71	1C	16	20	58	2C	25	00	A0	5A	00	00	00											
0x04	9E	01	1D	00	72	51	D0	1E	20	6E	28	55	00	A0	5A	00											
0x05	00	00	1E	8C	0A	D0	8A	20	E0	2D	10	10	3E	96	00	A0											
0x06	5A	00	00	00	18	26	36	80	A0	70	38	1B	40	30	20	25											
0x07	00	A0	5A	00	00	00	1A	00	00	00	00	00	00	00	00	Ⓣ2											

•Reference

- HDMI1 ~ HDMI3
- In the data of EDID, bellows may be different by S/W or Input mode.

ⓐ Product ID

HEX	EDID Table	DDC Function
0001	0100	Analog
0001	0100	Digital

- ⓑ Serial No: Controlled on production line.
- ⓒ Month, Year: Controlled on production line:
ex) Monthly : '01' -> '01'
Year : '2014' -> '18'
- ⓓ Model Name(Hex): LGTV

Chassis	MODEL NAME(HEX)
LA42B	00 00 00 FC 00 4C 47 20 54 56 0A 20 20 20 20 20 20

ⓔ Checksum(LG TV): Changeable by total EDID data.

	Ⓣ1	Ⓣ2	Ⓣ3
HDMI1	E7	02	X
HDMI2	E7	F2	X
HDMI3	E7	E2	X

ⓕ Vendor Specific(HDMI)

INPUT	MODEL NAME(HEX)
HDMI1	67 03 0C 00 10 00 B8 2D
HDMI2	67 03 0C 00 20 00 B8 2D
HDMI3	67 03 0C 00 30 00 B8 2D

4.4.3.3. 3D_8bit_PCM(US)_xvYCC : off

HDMI EDID 3D_8bit_PCM(US)_xvYCC : off

0x00	00	FF	FF	FF	FF	FF	FF	00	1E	6D	Ⓣ				Ⓣ												
0x01	Ⓣ	01	03	80	A0	5A	78	0A	EE	91	A3	54	4C	99	26												
0x02	0F	50	54	A1	08	00	31	40	45	40	61	40	71	40	81	80											
0x03	01	01	01	01	01	01	02	3A	80	18	71	38	2D	40	58	2C											
0x04	45	00	A0	5A	00	00	00	1E	66	21	50	B0	51	00	1B	30											
0x05	40	70	36	00	A0	5A	00	00	00	1E	00	00	00	FD	00	3A											
0x06	3E	1E	53	10	00	0A	20	20	20	20	20	Ⓣ															
0x07	Ⓣ															01	Ⓣ1										
0x00	02	03	2E	F1	48	90	22	20	05	04	03	02	01	23	09	57											
0x01	07	Ⓣ															E3	05	00	00	02	3A	80				
0x02	18	71	38	2D	40	58	2C	04	05	A0	5A	00	00	00	1E	01											
0x03	80	18	71	38	2D	40	58	2C	45	00	40	84	63	00	00	1E											
0x04	01	1D	80	18	71	1C	16	20	58	2C	25	00	40	84	63	00											
0x05	00	9E	01	1D	00	72	51	D0	1E	20	6E	28	55	00	40	84											
0x06	63	00	00	1E	00	00	00	00	00	00	00	00	00	00	00	00											
0x07	00	00	00	00	00	00	00	00	00	00	00	00	00	00	00	Ⓣ2											

•Reference

- HDMI1 ~ HDMI4
- In the data of EDID, bellows may be different by S/W or Input mode.

ⓐ Product ID

HEX	EDID Table	DDC Function
0001	0100	Analog
0001	0100	Digital

- ⓑ Serial No: Controlled on production line.
- ⓒ Month, Year: Controlled on production line:
ex) Monthly : '01' -> '01'
Year : '2014' -> '18'
- ⓓ Model Name(Hex): LGTV

Chassis	MODEL NAME(HEX)
LA42B	00 00 00 FC 00 4C 47 20 54 56 0A 20 20 20 20 20 20

ⓔ Checksum(LG TV): Changeable by total EDID data.

	Ⓣ1	Ⓣ2	Ⓣ3
HDMI1	E7	FC	X
HDMI2	E7	EC	X
HDMI3	E7	DC	X
HDMI4 (LB87 only)	E7	CC	X

ⓕ Vendor Specific(HDMI)

INPUT	MODEL NAME(HEX)
HDMI1	78 03 0C 00 10 00 80 1E 20 CO 0E 01 4F 00 FE 08 10 06 10 18 10 28 10 38 10
HDMI2	78 03 0C 00 20 00 80 1E 20 CO 0E 01 4F 00 FE 08 10 06 10 18 10 28 10 38 10
HDMI3	78 03 0C 00 30 00 80 1E 20 CO 0E 01 4F 00 FE 08 10 06 10 18 10 28 10 38 10
HDMI4 (LB87 Only)	78 03 0C 00 30 00 80 1E 20 CO 0E 01 4F 00 FE 08 10 06 10 18 10 28 10 38 10

4.4.3.4. 3D_10bit_PCM(US)_xvYCC : off

HDMI EDID 3D_10bit_PCM(US)_xvYCC : off

	0x00	0x01	0x02	0x03	0x04	0x05	0x06	0x07	0x08	0x09	0x0A	0x0B	0x0C	0x0D	0x0E	0x0F
0x00	00	FF	FF	FF	FF	FF	FF	00	1E	6D	Ⓢ		Ⓢ			
0x01	Ⓢ		01	03	80	A0	5A	78	0A	EE	91	A3	54	4C	99	26
0x02	0F	50	54	A1	08	00	31	40	45	40	61	40	71	40	81	80
0x03	01	01	01	01	01	01	02	3A	80	18	71	38	2D	40	58	2C
0x04	45	00	40	84	63	00	00	1E	66	21	50	B0	51	00	1E	30
0x05	40	70	36	00	40	84	63	00	00	1E	00	00	00	FD	00	3A
0x06	3E	1E	53	10	00	0A	20	20	20	20	20	Ⓢ		Ⓢ		
0x07	Ⓢ														01	Ⓢ1
0x08	02	03	2E	F1	48	90	22	20	05	04	03	02	01	23	09	57
0x09	07	Ⓢ														
0x0A	Ⓢ										E3	05	00	00	02	3A
0x0B	80	18	71	38	2D	40	58	2C	45	00	40	84	63	00	00	1E
0x0C	01	1D	80	18	71	1C	16	20	58	2C	25	00	40	84	63	00
0x0D	00	8E	01	1D	00	72	51	D0	1E	20	6E	28	55	00	40	84
0x0E	63	00	00	1E	00	00	00	00	00	00	00	00	00	00	00	00
0x0F	00	00	00	00	00	00	00	00	00	00	00	00	00	00	00	Ⓢ2

•Reference

- HDMI1 ~ HDMI3
- In the data of EDID, bellows may be different by S/W or Input mode.

Ⓢ Product ID

HEX	EDID Table	DDC Function
0001	0100	Analog
0001	0100	Digital

- Ⓢ Serial No: Controlled on production line.
- Ⓢ Month, Year: Controlled on production line:
ex) Monthly : '01' -> '01'
Year : '2014' -> '18'
- Ⓢ Model Name(Hex): LGTV

Chassis	MODEL NAME(HEX)
LA42B	00 00 00 FC 00 4C 47 20 54 56 0A 20 20 20 20 20 20

Ⓢ Checksum(LG TV): Changeable by total EDID data.

	Ⓢ1	Ⓢ2	Ⓢ3
HDMI1	E7	B5	X
HDMI2	E7	A5	X
HDMI3	E7	95	X

Ⓢ Vendor Specific(HDMI)

INPUT	MODEL NAME(HEX)
HDMI1	78 03 0C 00 10 00 B8 2D 20 C0 0E 01 4F 00 FE 08 10 06 10 18 10 28 10 38 10
HDMI2	78 03 0C 00 20 00 B8 2D 20 C0 0E 01 4F 00 FE 08 10 06 10 18 10 28 10 38 10
HDMI3	78 03 0C 00 30 00 B8 2D 20 C0 0E 01 4F 00 FE 08 10 06 10 18 10 28 10 38 10

5. Final Assembly Adjustment

5.1. White Balance Adjustment

5.1.1. Overview

- 5.1.1.1. W/B adj. Objective & How-it-works
- (1) Objective: To reduce each Panel's W/B deviation
 - (2) How-it-works: When R/G/B gain in the OSD is at 192, it means the panel is at its Full Dynamic Range. In order to prevent saturation of Full Dynamic range and data, one of R/G/B is fixed at 192, and the other two is lowered to find the desired value.
 - (3) Adj. condition: normal temperature
 - Surrounding Temperature: 25±5 °C
 - Warm-up time: About 5 Min
 - Surrounding Humidity: 20% ~ 80%
 - Before White balance adjustment, Keep power on status, don't power off

5.1.1.2. Adj. condition and cautionary items

- (1) Lighting condition in surrounding area surrounding lighting should be lower 10 lux. Try to isolate adj. area into dark surrounding.
- (2) Probe location: Color Analyzer (CA-210) probe should be within 10cm and perpendicular of the module surface (80°~ 100°)
- (3) Aging time
 - After Aging Start, Keep the Power ON status during 5 Minutes.
 - In case of LCD, Back-light on should be checked using no signal or Full-white pattern.

5.1.2. Equipment

- (1) Color Analyzer: CA-210 (NCG: CH 9 / WCG: CH12 / LED: CH14)
 - (2) Adj. Computer (During auto adj., RS-232C protocol is needed)
 - (3) Adjust Remocon
 - (4) Video Signal Generator MSPG-925F 720p/204-Gray (Model: 217, Pattern: 49)
- ※ Color Analyzer Matrix should be calibrated using CS-1000

5.1.3. Equipment connection

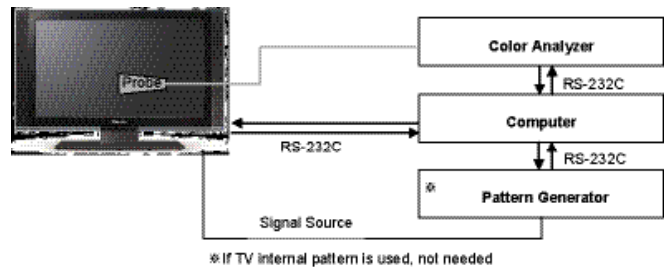

5.1.4. Adjustment Command (Protocol)

(1) RS-232C Command used during auto-adj.

RS-232C COMMAND			Explanation
CMD	DATA	ID	
Wb	00	00	Begin White Balance adj.
Wb	00	ff	End White Balance adj. (internal pattern disappears)

(2) Adjustment Map

	Adj. item	Command (lower caseASCII)		Data Range (Hex.)	
		CMD1	CMD2	MIN	MAX
Cool	R Gain	j	g	00	C0
	G Gain	j	h	00	C0
	B Gain	j	i	00	C0
Medium	R Gain	j	a	00	C0
	G Gain	j	b	00	C0
	B Gain	j	c	00	C0
Warm	R Gain	j	d	00	C0
	G Gain	j	e	00	C0
	B Gain	j	f	00	C0

5.1.5. Adjustment method

5.1.5.1. Auto WB calibration

- (1) Set TV in ADJ mode using P-ONLY key (or POWER ON key)
 - (2) Place optical probe on the center of the display
- It need to check probe condition of zero calibration before adjustment.
 - (3) Connect RS-232C Cable
 - (4) Select mode in ADJ Program and begin a adjustment.
 - (5) When WB adjustment is completed with OK message, check adjustment status of pre-set mode (Cool, Medium, Warm)
 - (6) Remove probe and RS-232C cable.
- W/B Adj. must begin as start command "wb 00 00" , and finish as end command "wb 00 ff", and Adj. offset if need

5.1.5.2. Manual adjustment

- (1) Set TV in Adj. mode using POWER ON
- (2) Zero Calibrate the probe of Color Analyzer, then place it on the center of LCD module within 10cm of the surface..
- (3) Press ADJ key -> EZ adjust using adj. R/C à 9. White-Balance then press the cursor to the right (KEY▶). When KEY(▶) is pressed 206 Gray internal pattern will be displayed.
- (4) Adjust Cool modes
 - (i) Fix the one of R/G/B gain to 192 (default data) and decrease the others.
(If G gain is adjusted over 172 and R and B gain less than 192 , Adjust is O.K.)
 - (ii) If G gain is less than 172, Increase G gain by up to 172, and then increase R gain and G gain same amount of increasing G gain.
 - (iii) If R gain or B gain is over 255, Readjust G gain less than 172, Conform to R gain is 255 or B gain is 255
- (5) Adjust two modes (Medium / Warm) Fix the one of R/G/B gain to 192 (default data) and decrease the others.
- (6) Adj. is completed, Exit adjust mode using "EXIT" key on Remote controller.

5.1.6. Reference (White Balance Adj. coordinate and color temperature)

- (1) Luminance: 204 Gray, 80IRE
- (2) Standard color coordinate and temperature using CS-1000 (over 26 inch)

5.1.7. Reference (White Balance Adj. coordinate and color temperature)

- Luminance: 204 Gray
- Standard color coordinate and temperature using CS-1000 (over 26 inch)

Mode	Coordinate		Temp	Δuv
	X	Y		
Cool	0.271	0.270	13,000K	0.0000
Medium	0.286	0.289	9,300K	0.0000
Warm	0.313	0.329	6,500K	0.0000

- Standard color coordinate and temperature using CA-210(CH-14) – by aging time
- (1) Normal line in Korea (From January to February) : LGD (LB5xxx, LB6xxx, LB7xxx, LB8xxx Series models)

GP4	Aging time (Min)	Cool		Medium		Warm	
		X	Y	X	Y	X	Y
		271	270	286	289	313	329
1	0-2	286	295	301	314	328	354
2	3-5	284	290	299	309	326	349
3	6-9	282	287	297	306	324	346
4	10-19	279	283	294	302	321	342
5	20-35	276	278	291	297	318	337
6	36-49	274	275	289	294	316	334
7	50-79	273	272	288	291	315	331
8	80-119	272	271	287	290	314	330
9	Over 120	271	270	286	289	313	329

- Standard color coordinate and temperature using CA-210(CH-14) – by aging time
- (2) Normal line in Korea (From March to December) : LGD (LB5xxx, LB6xxx, LB7xxx, LB8xxx Series models)
- Normal line in Mexico : LGD (LB5xxx, LB6xxx, LB7xxx, LB8xxx Series models)

GP4	Aging time (Min)	Cool		Medium		Warm	
		X	Y	X	Y	X	Y
		271	270	286	289	313	329
1	0-2	282	289	297	308	324	348
2	3-5	281	287	296	306	323	346
3	6-9	279	284	294	303	321	343
4	10-19	277	280	292	299	319	339
5	20-35	275	277	290	296	317	336
6	36-49	274	274	289	293	316	333
7	50-79	273	272	288	291	315	331
8	80-119	272	271	287	290	314	330
9	Over 120	271	270	286	289	313	329

- (3) O/S Module(AUO, INX, Sharp, CSOT, BOE)

	cool		med		warm	
	x	y	x	y	x	y
spec	271	270	286	289	313	329
target	278	280	293	299	320	339

5.2. Option selection per country

5.2.1. Overview

- Tool option selection is only done for models in Non-USA North America due to rating
- Applied model: LA42B Chassis applied to CANADA and MEXICO

5.2.2. Country Group selection

- Press ADJ key on the Adj. R/C, and then select Country Group Menu
- Depending on destination, select US, then on the lower Country option, select US, CA, MX.
Selection is done using +, - KEY

5.2.3. Tool Option inspection

- Press Adj. key on the Adj. R/C, then select Tool option

Model	Tool 1	Tool 2	Tool 3	Tool 4	Tool 5	Tool 6	Tool 7	Area
65LB7100-UC	33641	4114	25475	64582	43686	2426	33579	22282
65LB7100-UB	33641	4114	25475	64582	43686	2426	33579	22282
70LB7100-UC	39786	4114	25475	64582	43686	2394	43819	22282
60LB7100-UT	33640	4114	25475	64582	43686	2394	35627	22282
55LB7200-UB	134	4114	25475	64582	48038	2394	39723	22282
42LB6500-UM(AUO)	4258	4370	33667	64582	2726	2474	47915	22282
42LB6500-UM(LGD)	162	4370	33667	64582	11174	2474	47915	22282
47LB6500-UM								22282
50LB6500-UM	165	4370	33667	64582	11174	2426	47915	22282
55LB6500-UM	166	4370	33155	64582	11174	2394	47915	22282
60LB6500-UP								22282
42LB6300-UQ								22282
47LB6300-UQ	259	4379	33155	64582	9126	2427	47915	22282
55LB6300-UQ								22282
60LB6300-US								22282
65LB6300-UA								22282
55LB8700-UA	70	4627	25236	64774	43434	2377	33291	22282

* Tool option can be reconstructed by Software

5.3. Local Dimming Inspection

(1) Press 'TILT' key of the Adj. R/C and check moving patterns. The black bar patterns moves from top to bottom. If a local dimming function does not work, a whole screen shows full white.



<Local dimming for 55LB8700-UA>

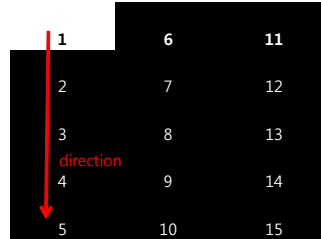

<Local dimming for 42LB67/68/69/7200-U*>

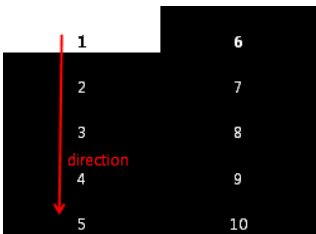

<Local dimming for 47LB67/68/69/73/7500-U*>

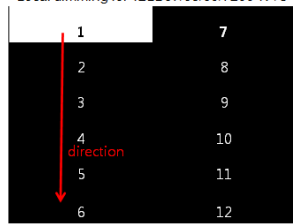

<Local dimming for 50/55/60LB67/68/69/72/73/7500-U*>

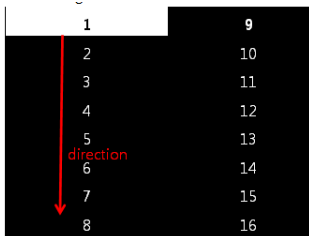

<Local dimming for 65LB67/68/69/7200-U*>

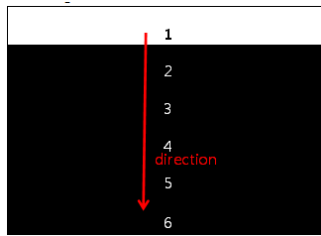

<Local dimming for 60LB7100-U*>

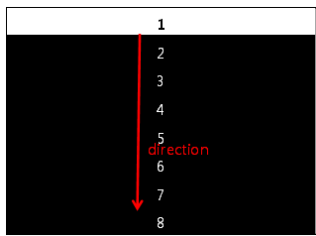

<Local dimming for 65LB7100-U*>

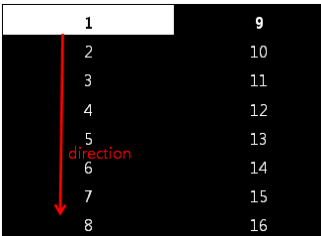

<Local dimming for 70LB7100-U*>

5.4. Magic Motion remote controller Check

5.4.1. Test equipment

- RF-remote controller for check, IR-KEY-CODE remote controller.
- Check AA battery before test. A recommendation is that a tester change battery every lots.

5.4.2. Test

- (1) Make pairing with TV set by pressing "Start key(Wheel key)" on RCU.
- (2) Check a cursor on screen by pressing "Wheel key" of RCU
- (3) Stop pairing with TV set by pressing "Back+ Home" key of RCU

5.4.3. Applied models

Chassis	Model Name	Magic RF receiver
LA42A	55LB8700-UA	Built-in
LA42B	55LB7200-U* 60/65/70LB7100-U* 42/47/50/55/60LB500-U* 42/47/55/60/65LB6300-U* 32LN570B-UH 47/55LN5790-UH 47/55LA6450-UA	Built-in

5.5. Wi-Fi MAC Address Check

5.5.1. Using RS232 Command

	Command	Set ACK
Transmission	[A][][][Set ID][][20][Cr]	[O][K][x] or [N][G]

5.5.2. Check the menu on in-start

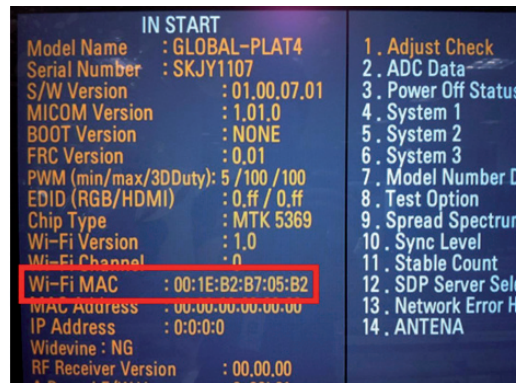

5.6. 3D pattern test (Only for 3D models)

5.6.1. Test equipment

- (1) Pattern Generator MSHG-600 or MSPG-6100 (HDMI 1.4 support)
- (2) Pattern: HDMI mode (model No. 872, pattern No. 83)

5.6.2. Test method

- (1) Input 3D test signal as Fig.1.



Fig.1
 <HDMI Mode 872번, Pattern No. 83>

- (2) Press 'OK' key as a 3D input OSD is shown.
- (3) Check pattern as Fig2 without 3D glasses. (3D mode without 3D glasses)



Fig.2
 <OK in 3D mode without 3D glasses>



Fig.3
 <NG in 3D mode without 3D glasses>

5.6.3. 3D Inner pattern

- (1). Using RS232 Command

	Command	Set ACK
Transmission	[A][I][][Set ID][][72][Cr]	[O][K][x] or [N][G][x]

- (2) It support internal 3D pattern without 'MASTER' equipment. Except that one, other method is same when use the 'MASTER' equipment

5.7. HDMI ARC Function Inspection

5.7.1. Test equipment

- Optic Receiver Speaker
- MSHG-600 (SW: 1220 ↑)
- HDMI Cable (for 1.4 version)

5.7.2. Test method

- (1) Insert the HDMI Cable to the HDMI ARC port from the master equipment (HDMI1)



- (2) Check the sound from the TV Set



- (3) Check the Sound from the Speaker or using AV & Optic TEST program (It's connected to MSHG-600)

Flow Line



Cell Line



- * Remark: Inspect in Power Only Mode and check SW version in a master equipment



5.8. HDMI MHL Function Inspection

5.8.1. Test method

- (1) Insert the HDMI Cable to the HDMI MHL port from the master equipment, HDMI3, HDMI4 (Only LB86, LB87)
- (2) Check the Green LED of Tester, and TV Display.



사진 1. MHL Tester (OK)
Picture 1. MHL Function Tester (OK)

사진 2. MHL Tester (NG)
Picture 2. MHL Function Tester (NG)

5.9. EYE-Q Green Function Inspection

- Step 1) Turn on the TV..
- Step 2) Press 'EYE' button on the adjustment remote-controller.
- Step 3) Cover 'Eye Q sensor' on the front of set with your hands, hold it for 6 seconds.
- Step 4) Check "the Sensor Data" on the screen, make certain that Data is below 10. If Data isn't below 10 in 6 seconds, Eye Q sensor would be bad. You should change Eye Q sensor.
- Step 5) Uncover your hands from Eye Q sensor, hold it for 6 seconds.
- Step 6) Check "Back Light(xxx)" on the screen, check data increase . You should change Eye Q sensor.

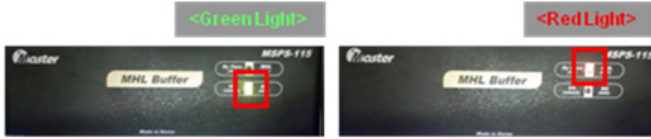
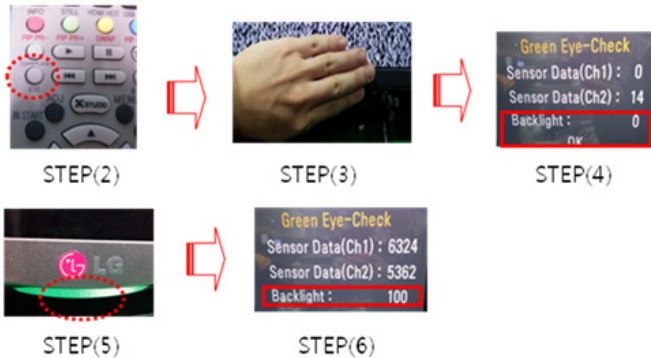

6. Camera Port Inspection

- (1) Objective : To check how it connects between Camera and PCBA normally, and their Function
- (2) Test Method : This Inspection is available only Power-Only Status
 - i) Push Camera Up.
 - ii) Camera's Preview picture appears on TV Set.
 - iii) Push Camera Down

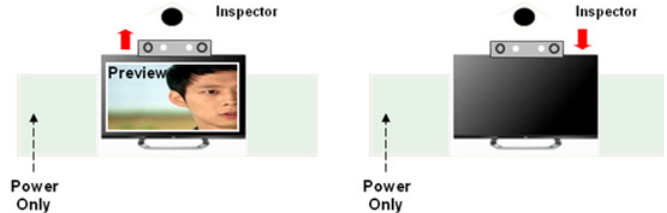

6.1. Ship-out mode check (In-stop)

- after final inspection, press In-Stop key of the Adj. R/C and check that the unit goes to Stand-by mode

7. AUDIO output check

7.1. Audio input condition

- (1) RF input: Mono, 1KHz sine wave signal, 100% Modulation
- (2) CVBS, Component: 1KHz sine wave signal (0.4Vrms)

7.2. Specification

No	Item	Min	Typ	Max	Unit	Remark
1	Audio practical max Output, L/R (Distortion=10% max Output)	9.0	10.0	12.0	W Vrms	(1) Measurement condition - EQ/AVL/Clear Voice: Off (2) Speaker (8Ω Impedance) ALL MODEL (Except LB86, LB87)
		8.5	8.9	9.9		
		13.5	15.0	18.0	W Vrms	(1) Measurement condition - EQ/AVL/Clear Voice: Off (2) Speaker (8Ω Impedance) Only LB86, LB87
		10.4	11.0	12.0		

8. GND and HI-POT Test

8.1. GND & HI-POT auto-check preparation

- (1) Check the POWER CABLE and SIGNAL CABLE insertion condition

8.2. GND & HI-POT auto-check

- (1) Pallet moves in the station. (POWER CORD / AV CORD is tightly inserted)
- (2) Connect the AV JACK Tester.
- (3) Controller (GWS103-4) on.
- (4) GND Test (Auto)
 - If Test is failed, Buzzer operates.
 - If Test is passed, execute next process (Hi-pot test). (Remove A/V CORD from A/V JACK BOX)
- (5) HI-POT test (Auto)
 - If Test is failed, Buzzer operates.
 - If Test is passed, GOOD Lamp on and move to next process automatically.

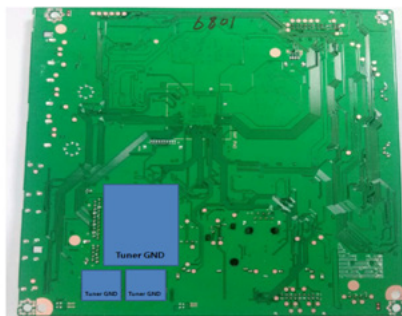

<Tuner GND is separated>

8.3. Checkpoint

- (1) Test voltage
 - GND: 1.5KV/min at 100mA
 - SIGNAL: 3KV/min at 100mA
- (2) TEST time: 1 second
- (3) TEST POINT
 - GND Test = POWER CORD GND and SIGNAL CABLE GND.
 - Hi-pot Test = POWER CORD GND and LIVE & NEUTRAL.
- (4) LEAKAGE CURRENT: At 0.5mA

9. USB S/W Download

(optional, Service only)

- (1) Put the USB Stick to the USB socket
- (2) Automatically detecting update file in USB Stick
 - If your downloaded program version in USB Stick is lower than that of TV set, it didn't work. Otherwise USB data is automatically detected.
- (3) Show the message "Copying files from memory"

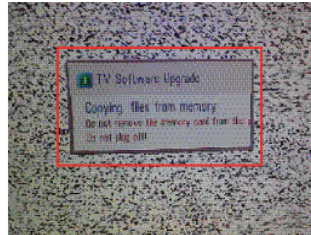

- (4) Updating is starting.

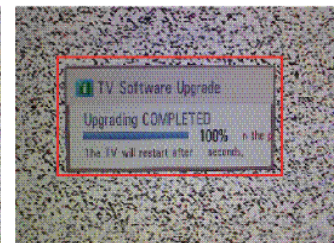
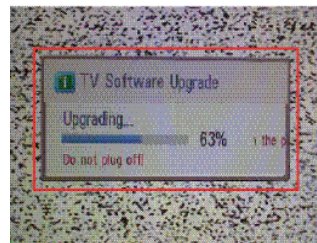

- (5) Updating Completed, The TV will restart automatically
- (6) If your TV is turned on, check your updated version and Tool option.

* If downloading version is more high than your TV have, TV can lost all channel data. In this case, you have to channel recover. If all channel data is cleared, you didn't have a DTV/ATV test on production line.

* After downloading, TOOL OPTION setting is needed again.

- (1) Push "IN-START" key in service remote controller.
- (2) Select "Tool Option 1" and Push "OK" button.
- (3) Punch in the number. (Each model has their number.)

10. Optional adjustments

10.1. Manual White balance Adjustment

10.1.1. Adj. condition and cautionary items

- (1) Lighting condition in surrounding area surrounding lighting should be lower 10 lux. Try to isolate adj. area into dark surrounding.
- (2) Probe location: Color Analyzer (CA-210) probe should be within 10cm and perpendicular of the module surface (80°~ 100°)
- (3) Aging time
 - After Aging Start, Keep the Power ON status during 5 Minutes.
 - In case of LCD, Back-light on should be checked using no signal or Full-white pattern

10.1.2. Equipment

- (1) Color Analyzer: CA-210 (NCG: CH 9 / WCG: CH12 / LED: CH14)
- (2) Adj. Computer (During auto adj., RS-232C protocol is needed)
- (3) Adjust Remocon
- (4) Video Signal Generator MSPG-925F 720p/216-Gray (Model: 217, Pattern: 78)

10.1.3. Adjustment

- (1) Set TV in Adj. mode using POWER ON
- (2) Zero Calibrate the probe of Color Analyzer, then place it on the center of LCD module within 10cm of the surface.
- (3) Press ADJ key -> EZ adjust using adj. R/C -> 6. White-Balance then press the cursor to the right (KEY▶).
When KEY(▶) is pressed 216 Gray internal pattern will be displayed.
- (4) One of R Gain / G Gain / B Gain should be fixed at 192, and the rest will be lowered to meet the desired value.
- (5) Adj. is performed in COOL, MEDIUM, WARM 3 modes of color temperature.

- If internal pattern is not available, use RF input. In EZ Adj. menu 6.White Balance, you can select one of 2 Test-pattern: ON, OFF. Default is inner(ON). By selecting OFF, you can adjust using RF signal in 216 Gray pattern.

EXPLODED VIEW

IMPORTANT SAFETY NOTICE

Many electrical and mechanical parts in this chassis have special safety-related characteristics. These parts are identified by Δ in the Schematic Diagram and EXPLODED VIEW. It is essential that these special safety parts should be replaced with the same components as recommended in this manual to prevent X-RADIATION, Shock, Fire, or other Hazards. Do not modify the original design without permission of manufacturer.

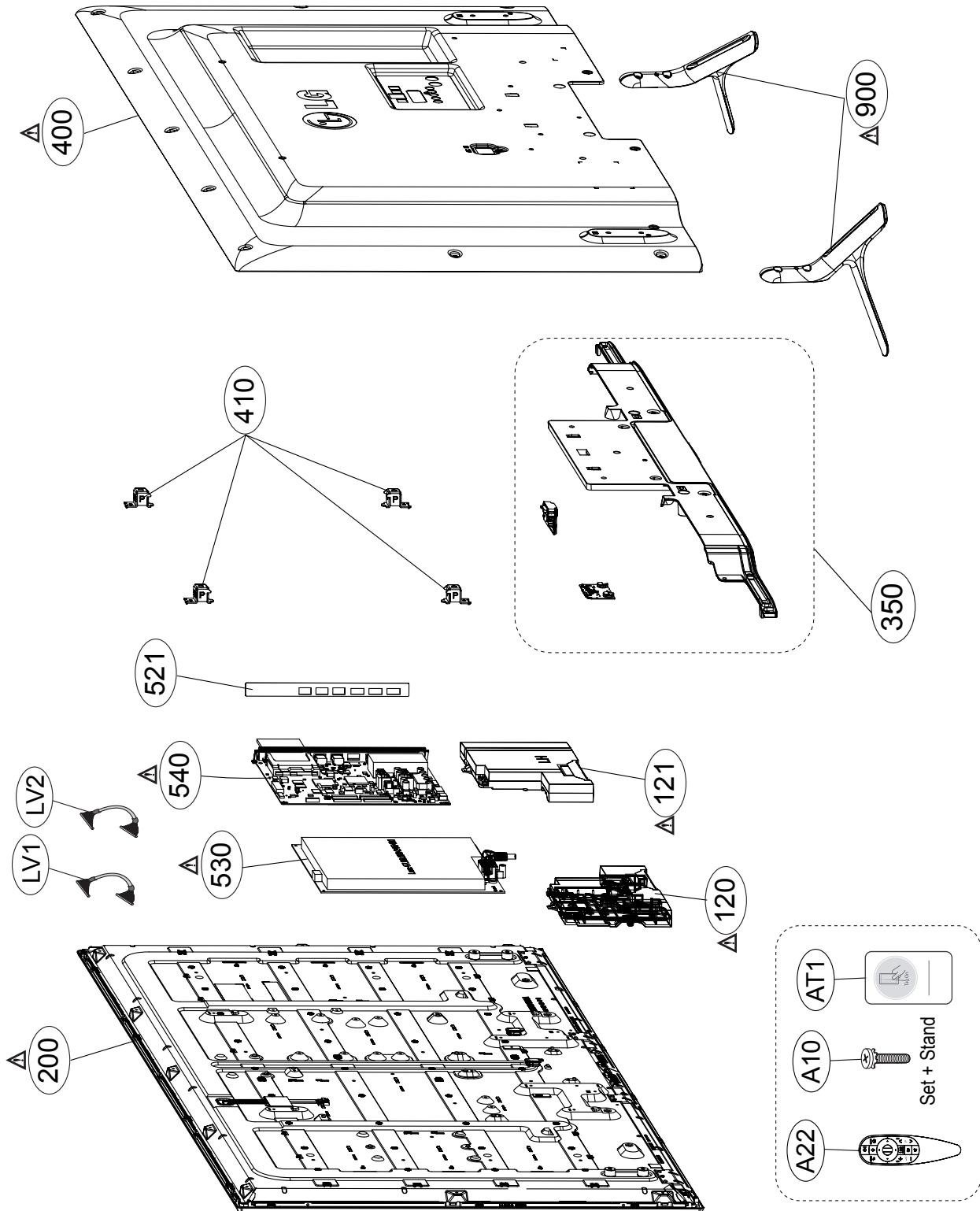

System Configuration

Clock for M14-A0

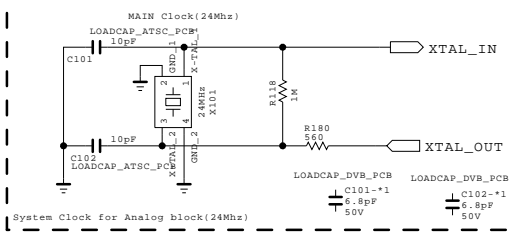

NVRAM

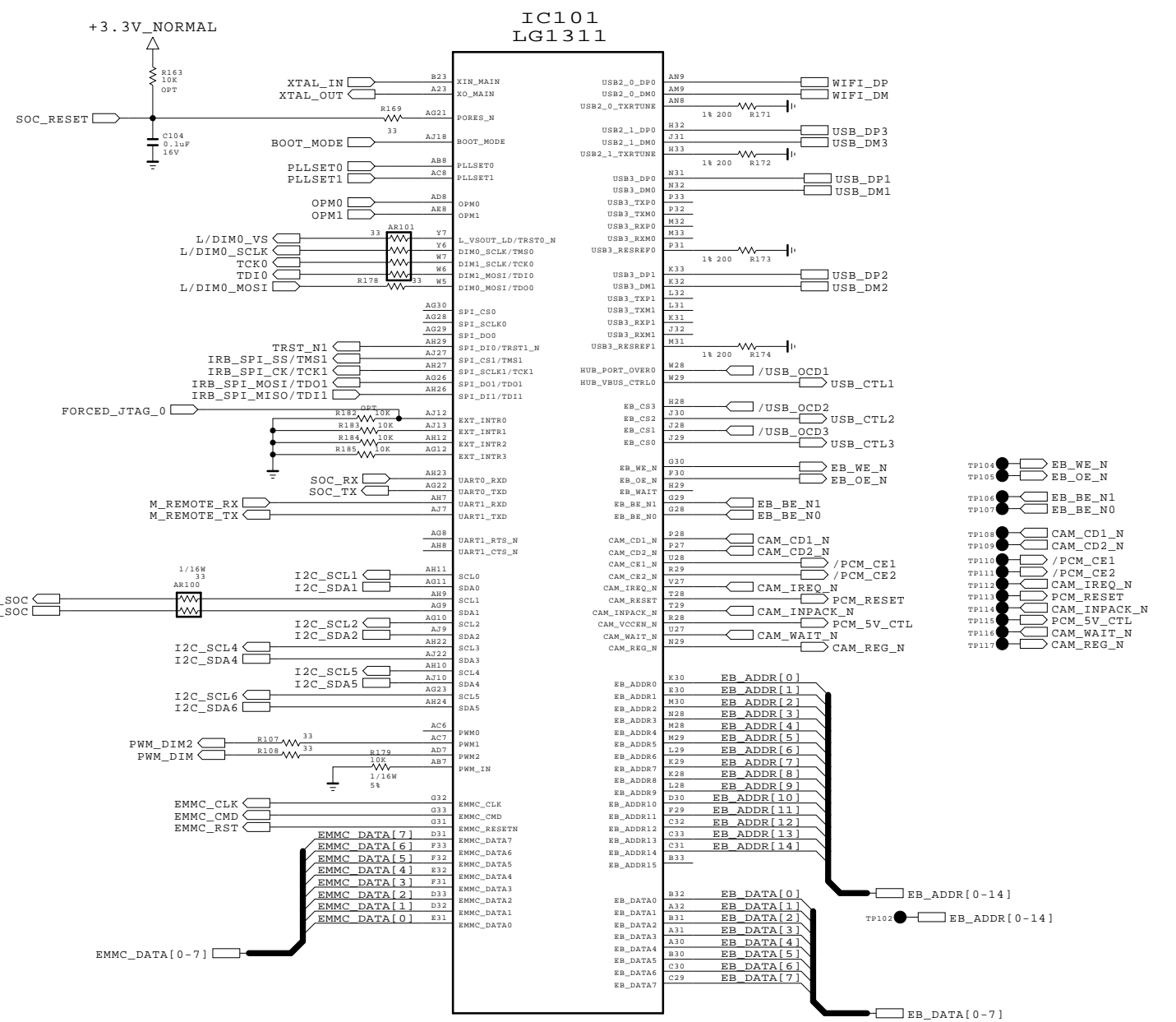
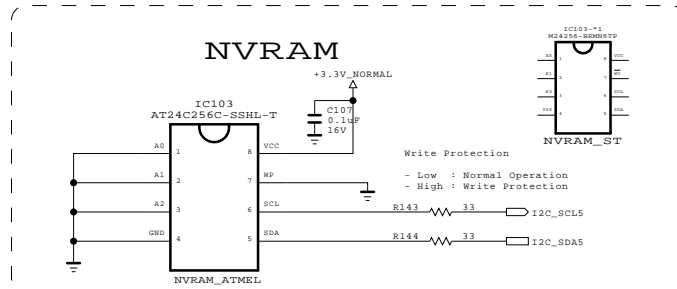

PLL SET[1:0] : internal pull up
 00 : CPU(1200MHz), M0 / M1 DDR(792.792 Mhz)
 01 : CPU(1050MHz), M0 / M1 DDR(792.792 Mhz)
 10 : CPU(1050MHz), M0 / M1 DDR(792.792 Mhz)
 11 : CPU(960MHz), M0 / M1 DDR(792.792 Mhz)

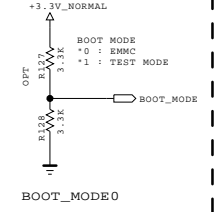
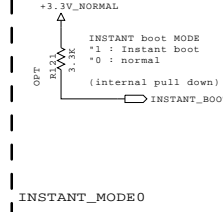
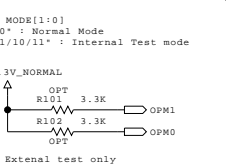
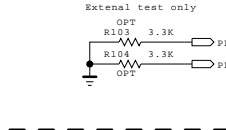

I2C

- I2C_1 : AMP
- I2C_2 : T-CON, L/DIMING
- I2C_3 : MICOM
- I2C_4 : S/Demod, T2/Demod, LNB
- I2C_5 : NVRAM
- I2C_6 : TUNER_MOPL(T/C, ATV)

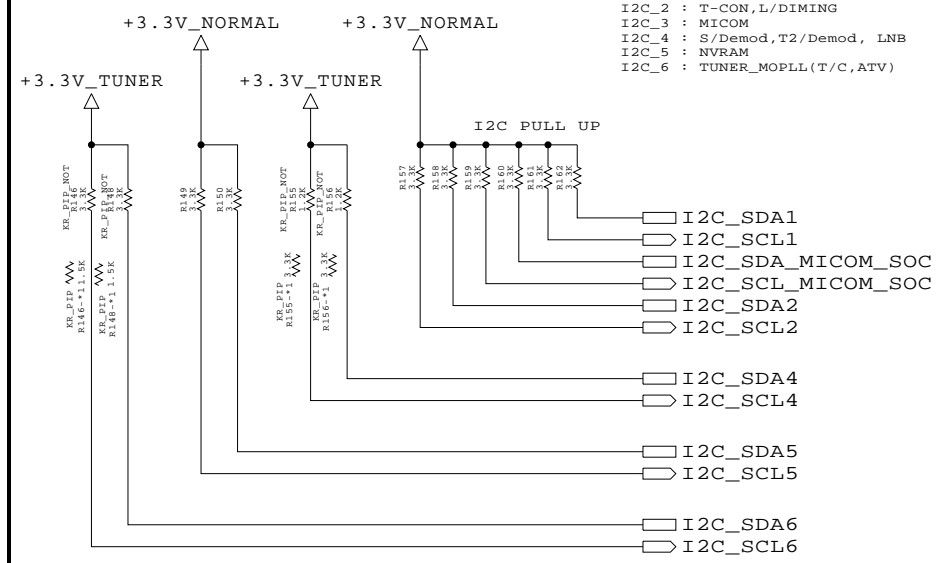

LOCAL DIMMING I2C CONTROL

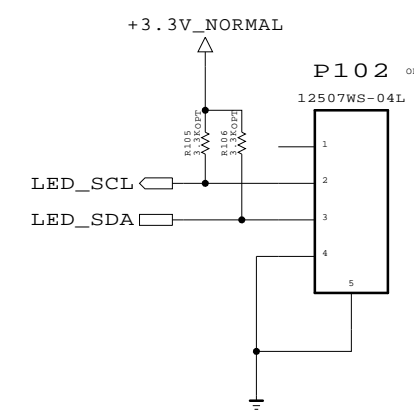

Jtag-0 I/F

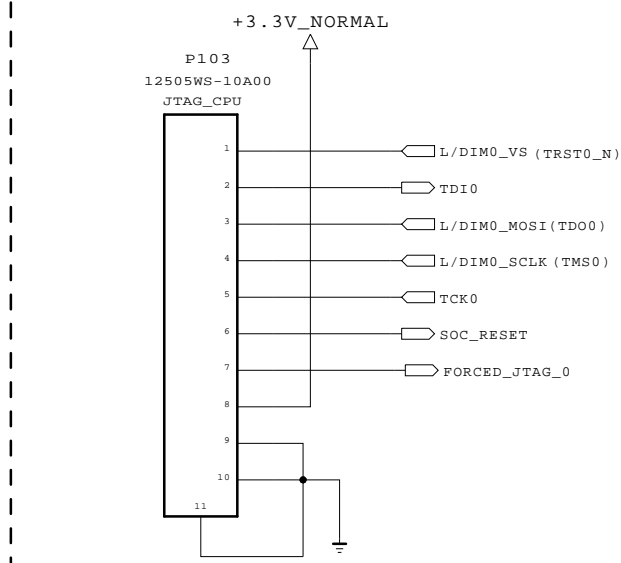

Jtag-1 I/F

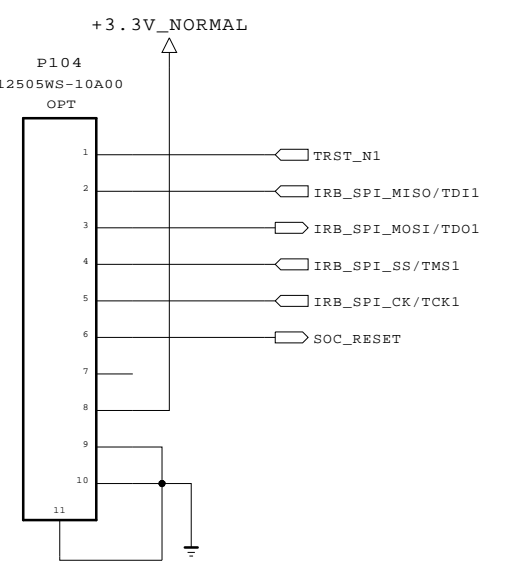

THE SYMBOL MARK OF THIS SCHEMATIC DIAGRAM INCORPORATES SPECIAL FEATURES IMPORTANT FOR PROTECTION FROM X-RADIATION. FIRE AND ELECTRICAL SHOCK HAZARDS, WHEN SERVICING IF IS ESSENTIAL THAT ONLY MANUFACTURERS SPECIFIED PARTS BE USED FOR THE CRITICAL COMPONENTS IN THE SYMBOL MARK OF THE SCHEMATIC.

SECRET
 LG Electronics



MODEL	MID_LG1311	DATE	2013.04.04
BLOCK	M14 Symbol A	SHEET	1 / 31

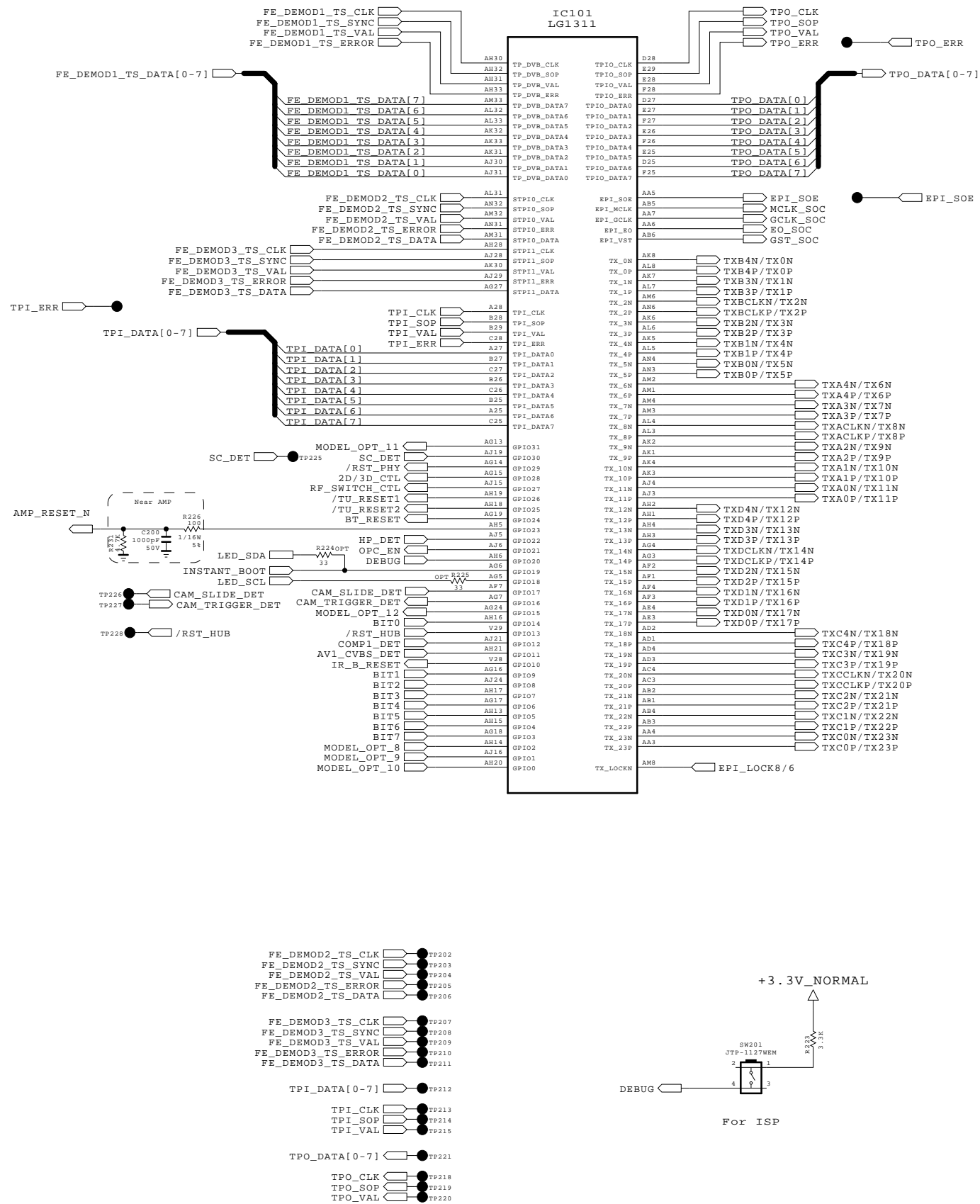

BIT [6/7]	EU/CIS	AJJA	TAIWAN/COL	CHINA/HONG	KOREA	NORTH AMERICA	BRAZIL	JAPAN
0 / 0	T/C	T/C	T/C	Default	ATSC PIP	ATSC PIP	ISDB PIP	Default
0 / 1	T2/C/82/ATV_EXT	T2/C/ATV_EXT	T2/C PIP		ATV_SDC	ATV_SDC	ISDB	
1 / 0	T2/C	T2/C/ATV_SDC	T2/C		ATV_EXT	ATV_EXT		
1 / 1	T2/C/82/ATV_SDC	T2/C/82						

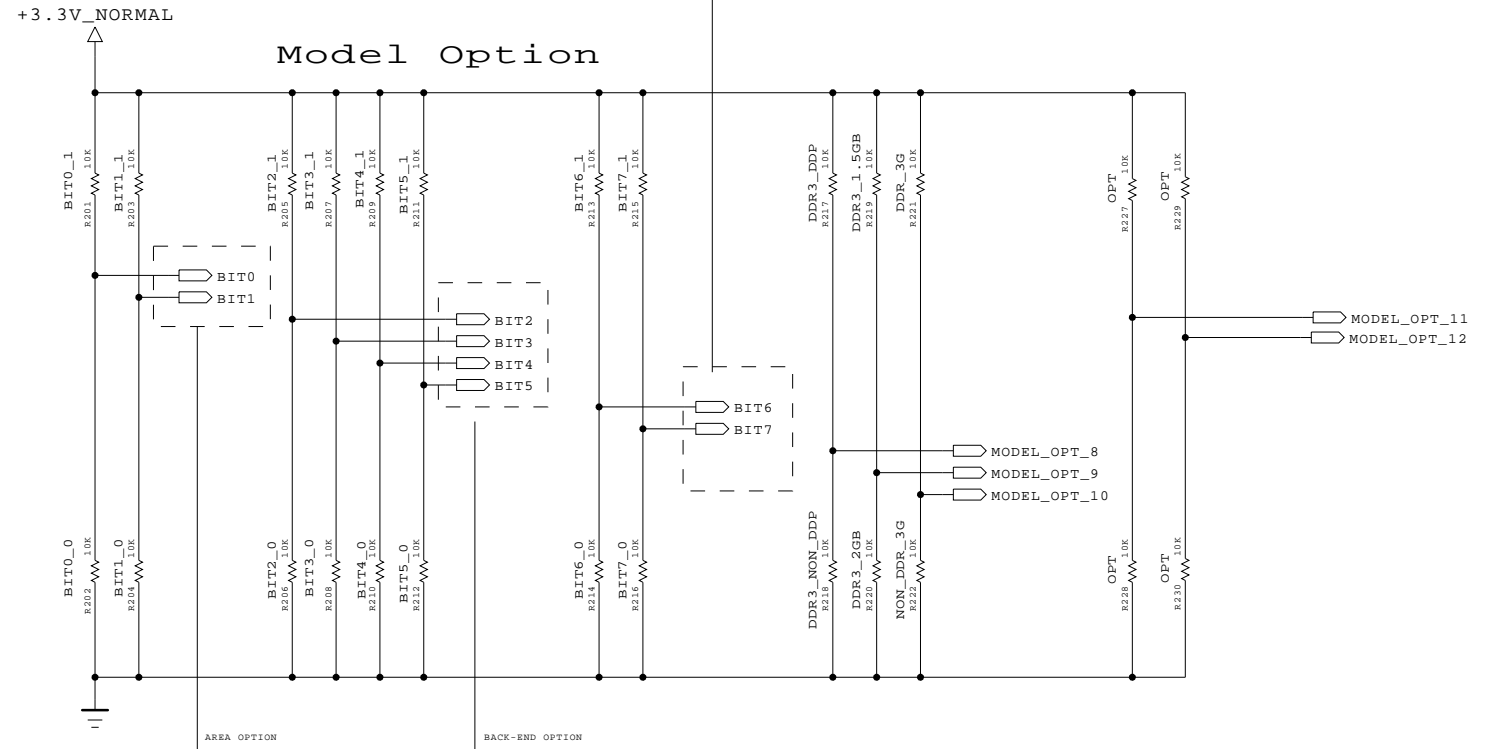

BIT [0/1]	DVB	ATSC	JP
0 / 0	TAIWAN/COLON	N/AMERICA	
0 / 1	CHINA/HONGKONG	KOREA	JAPAN
1 / 0	EU/CIS	S/AMERICA	
1 / 1	ASIA/AFRICA		

BIT[2/3/4/5]	TYPE	FHD	FRC	PANEL TYPE
0 / 0 / 0 / 0	EPI	FHD	120Hz	V14 (8 lane)
0 / 0 / 0 / 1	EPI	FHD	120Hz	V14.32inch (6 lane)
0 / 0 / 1 / 1	EPI	FHD	120Hz	V13 (6 lane)
0 / 0 / 1 / 0	EPI	FHD	120Hz	V12 (6 lane)
0 / 1 / 0 / 0	EPI	FHD	60Hz	V14.32 inch (6lane)
0 / 1 / 0 / 1	LVDS	FHD	120Hz	
0 / 1 / 1 / 0	LVDS	FHD	60Hz	
0 / 1 / 1 / 1	LVDS	HD	60Hz	
1 / 0 / 0 / 0	LVDS	FHD	60Hz	CP BOX
1 / 0 / 0 / 1	LVDS	HD	60Hz	SMALL SMART
1 / 0 / 1 / 0	Vby1	FHD	120Hz	OLED
1 / 0 / 1 / 1	LVDS	FHD	120Hz	OLED
1 / 1 / 0 / 0				
1 / 1 / 0 / 1				
1 / 1 / 1 / 0				
1 / 1 / 1 / 1				

MODEL_OPTION	LOW	HIGH
MODEL_OPT_8	DDR3	DDP
MODEL_OPT_9	DDR3	2GB
MODEL_OPT_10	FOR UD	NOM_DDR3_3G
MODEL_OPT_11		DDR3_3G
MODEL_OPT_12		

THE SYMBOL MARK OF THIS SCHEMATIC DIAGRAM INCORPORATES SPECIAL FEATURES IMPORTANT FOR PROTECTION FROM X-RADIATION. FIRE AND ELECTRICAL SHOCK HAZARDS, WHEN SERVICING IF IS ESSENTIAL THAT ONLY MANUFACTURERS SPECIFIED PARTS BE USED FOR THE CRITICAL COMPONENTS IN THE SYMBOL MARK OF THE SCHEMATIC.

SECRET
LGElectronics



MODEL	MID_LG1311	DATE	2013.04.04
BLOCK	M14 Symbol B	SHEET	2 / 31

Place JACK Side

Place SOC Side

AV1_CVBS/COMP1_Y Circuit was moved to 34Page

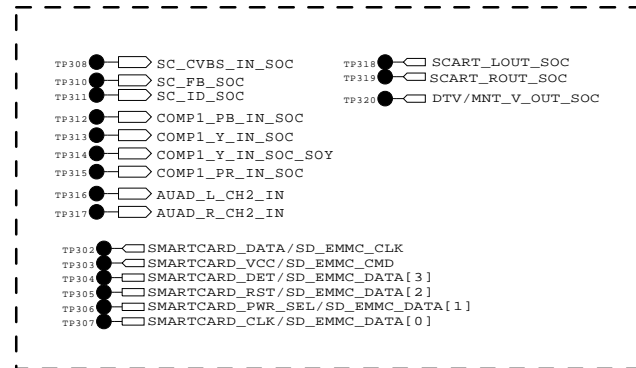
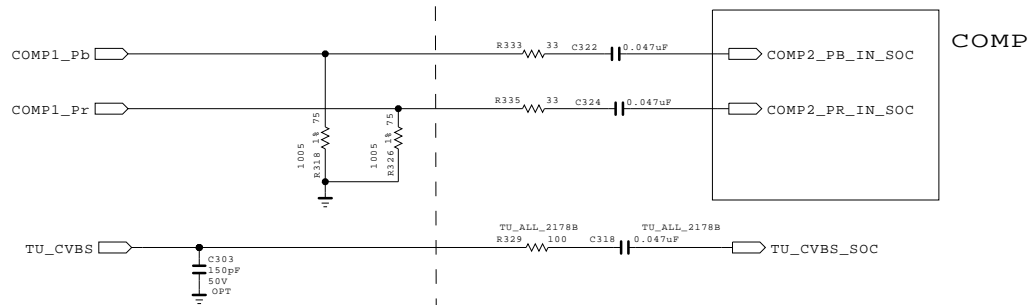

Placed as close as possible to LG1311

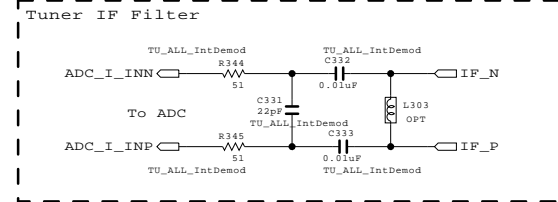

Placed as close as possible to IC101

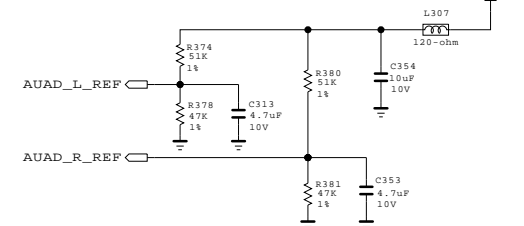

DDR3 VENDOR OPTION

+3.3V_NORMAL

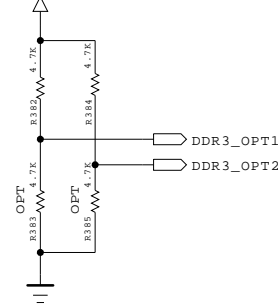

AUDIO OUT

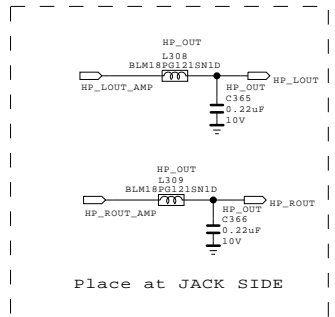
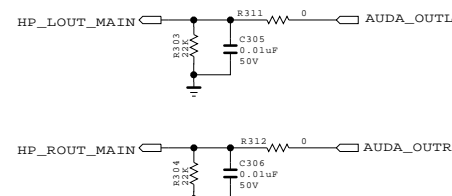

Place at JACK SIDE

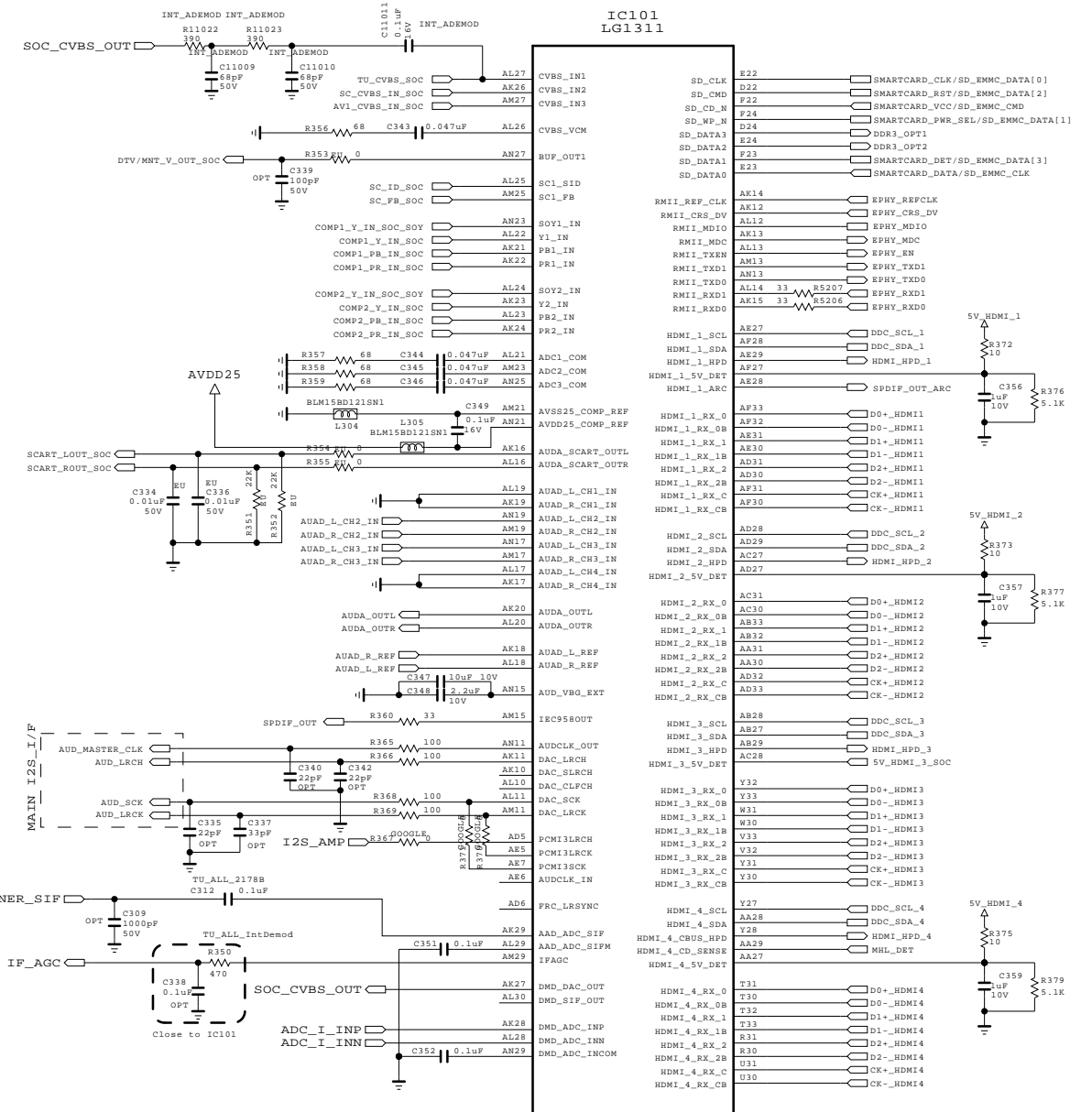

THE Δ SYMBOL MARK OF THIS SCHEMATIC DIAGRAM INCORPORATES SPECIAL FEATURES IMPORTANT FOR PROTECTION FROM X-RADIATION. FIRE AND ELECTRICAL SHOCK HAZARDS, WHEN SERVICING IT IS ESSENTIAL THAT ONLY MANUFACTURERS SPECIFIED PARTS BE USED FOR THE CRITICAL COMPONENTS IN THE Δ SYMBOL MARK OF THE SCHEMATIC.

SECRET
LGElectronics



MODEL	MID_LG1311	DATE	2013.04.04
BLOCK	M14 Symbol C	SHEET	3 / 31

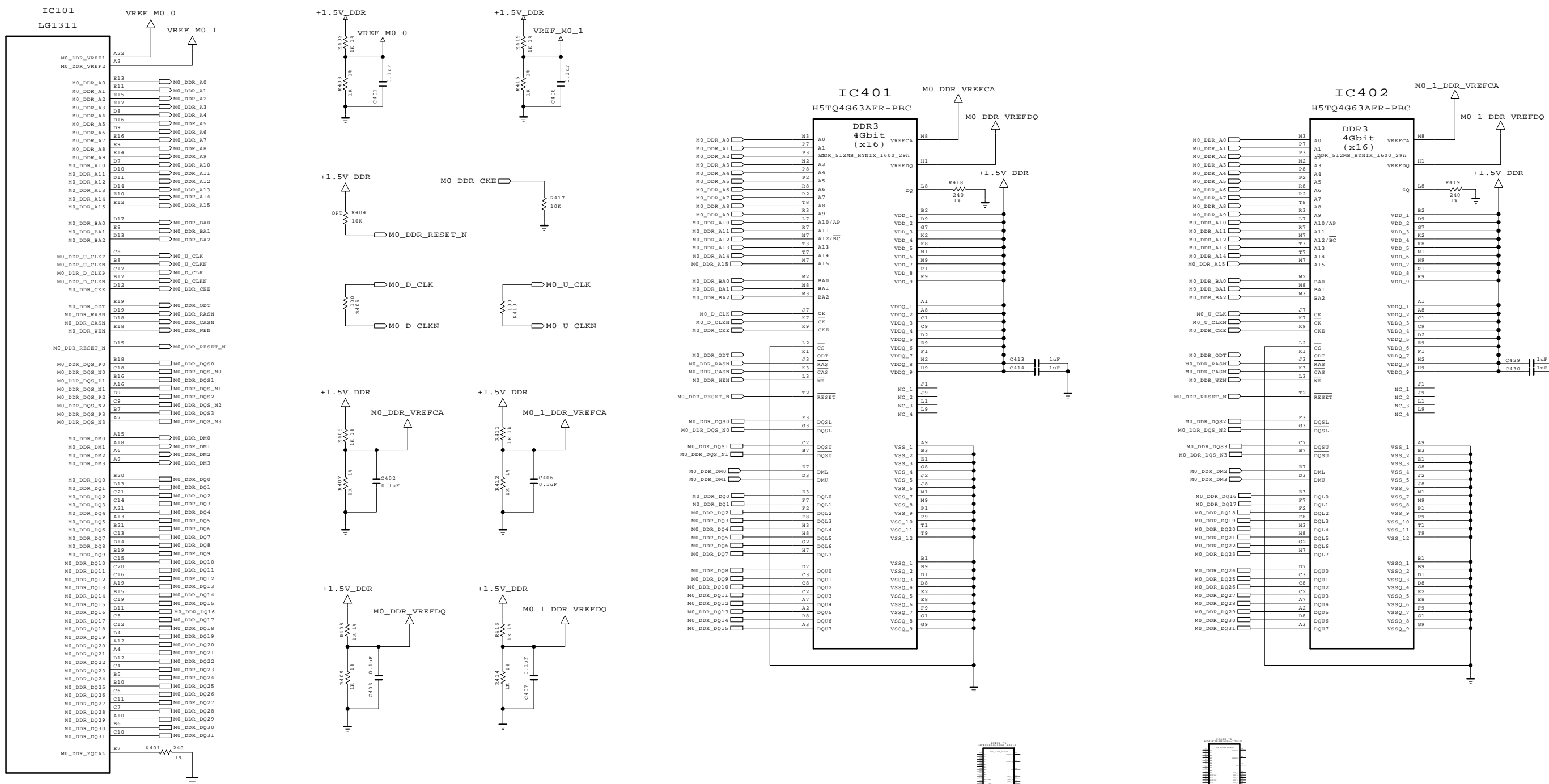

THE Δ SYMBOL MARK OF THIS SCHEMATIC DIAGRAM INCORPORATES SPECIAL FEATURES IMPORTANT FOR PROTECTION FROM X-RADIATION. FIRE AND ELECTRICAL SHOCK HAZARDS, WHEN SERVICING IF IS ESSENTIAL THAT ONLY MANUFACTURERS SPECIFIED PARTS BE USED FOR THE CRITICAL COMPONENTS IN THE Δ SYMBOL MARK OF THE SCHEMATIC.

SECRET
LGElectronics

LG ELECTRONICS

MODEL	MID_LG1311	DATE	2013.04.04
BLOCK	M14 DDR3-M0	SHEET	4 / 31

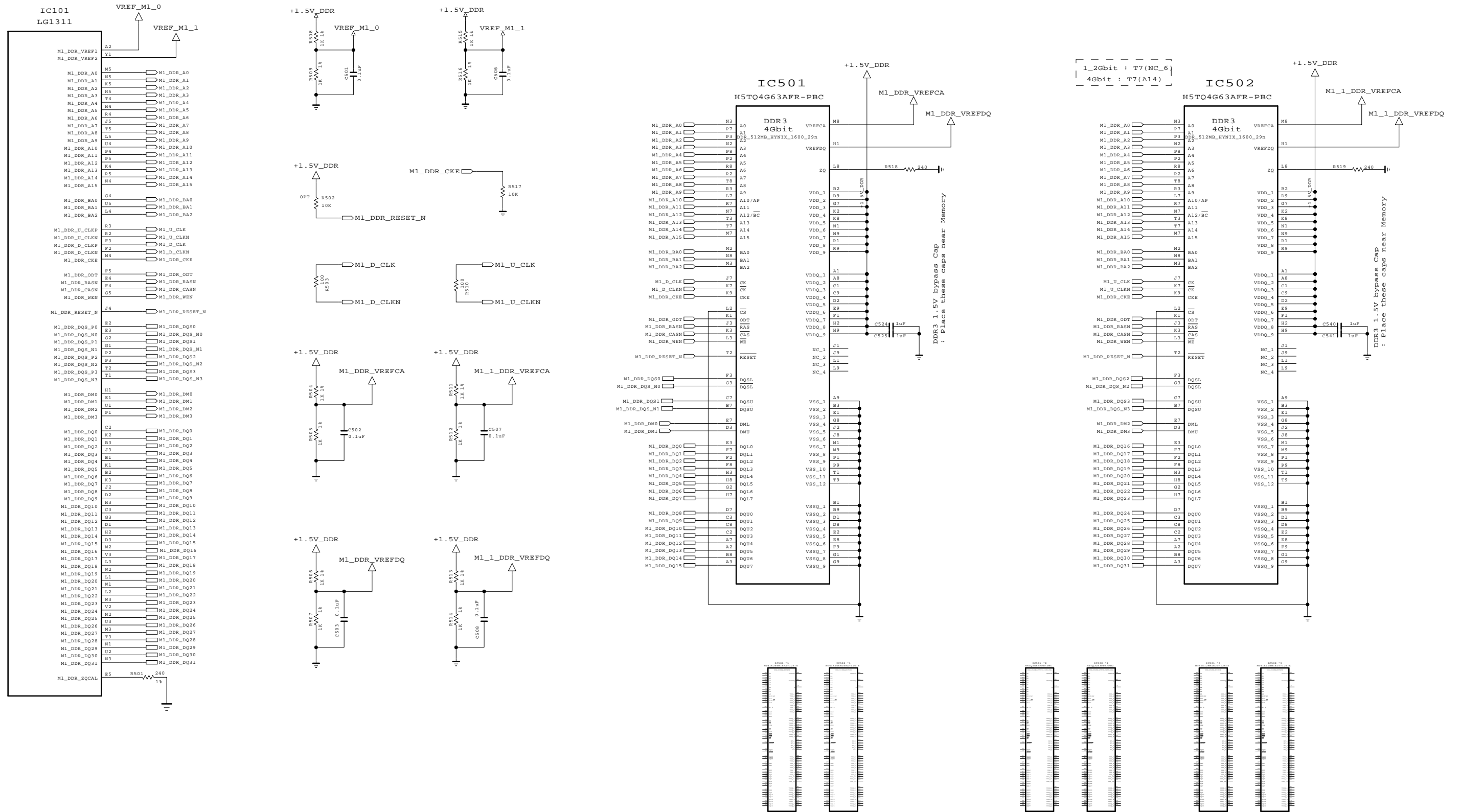

THE Δ SYMBOL MARK OF THIS SCHEMATIC DIAGRAM INCORPORATES SPECIAL FEATURES IMPORTANT FOR PROTECTION FROM X-RADIATION. FIRE AND ELECTRICAL SHOCK HAZARDS, WHEN SERVICING IF IS ESSENTIAL THAT ONLY MANUFACTURES SPECIFIED PARTS BE USED FOR THE CRITICAL COMPONENTS IN THE Δ SYMBOL MARK OF THE SCHEMATIC.

SECRET
LGElectronics

LG ELECTRONICS

MODEL	MID_LG1311	DATE	2013.04.04
BLOCK	M14 DDR3-M1	SHEET	5 / 31

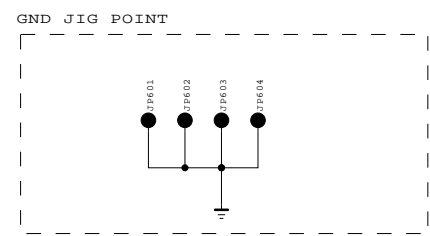
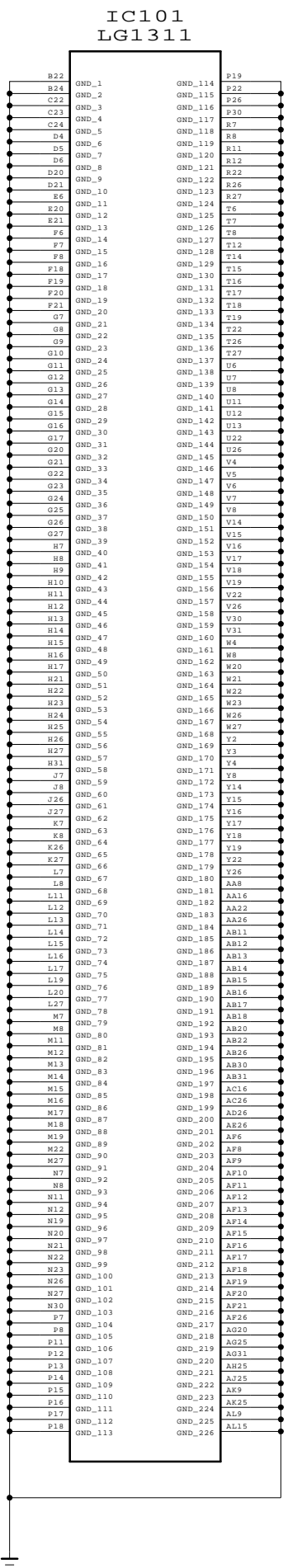
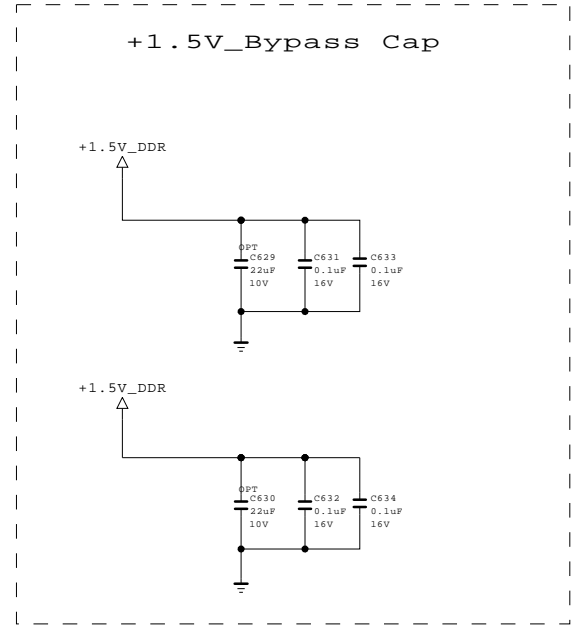
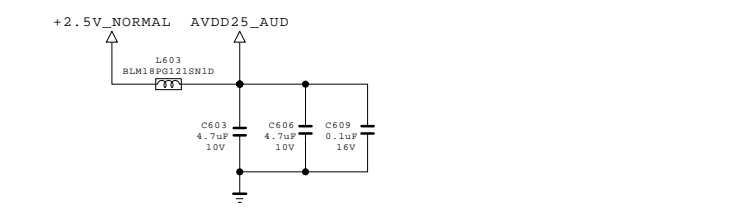
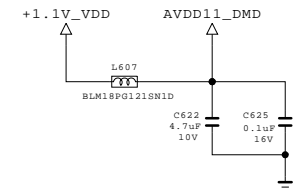
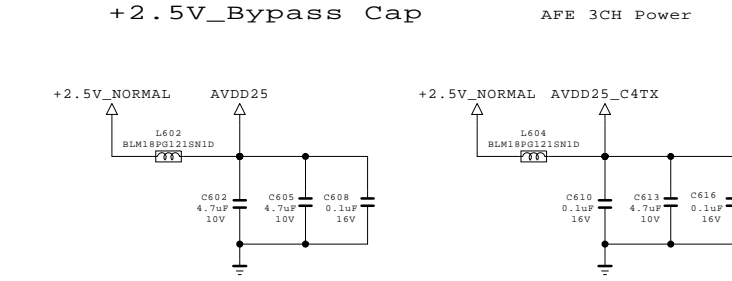
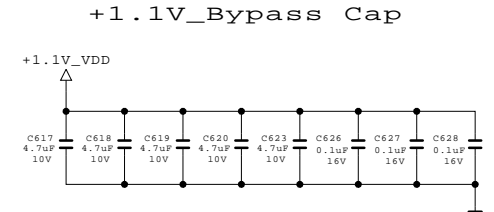
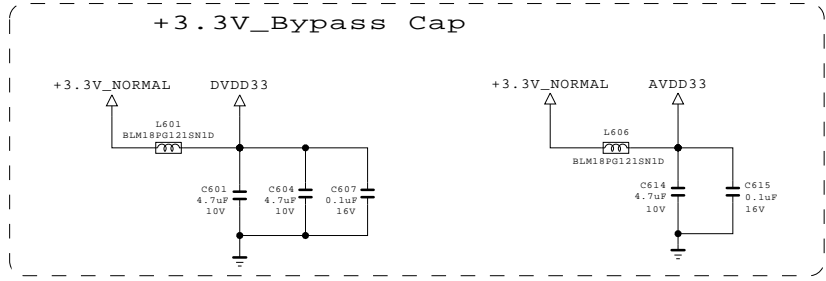
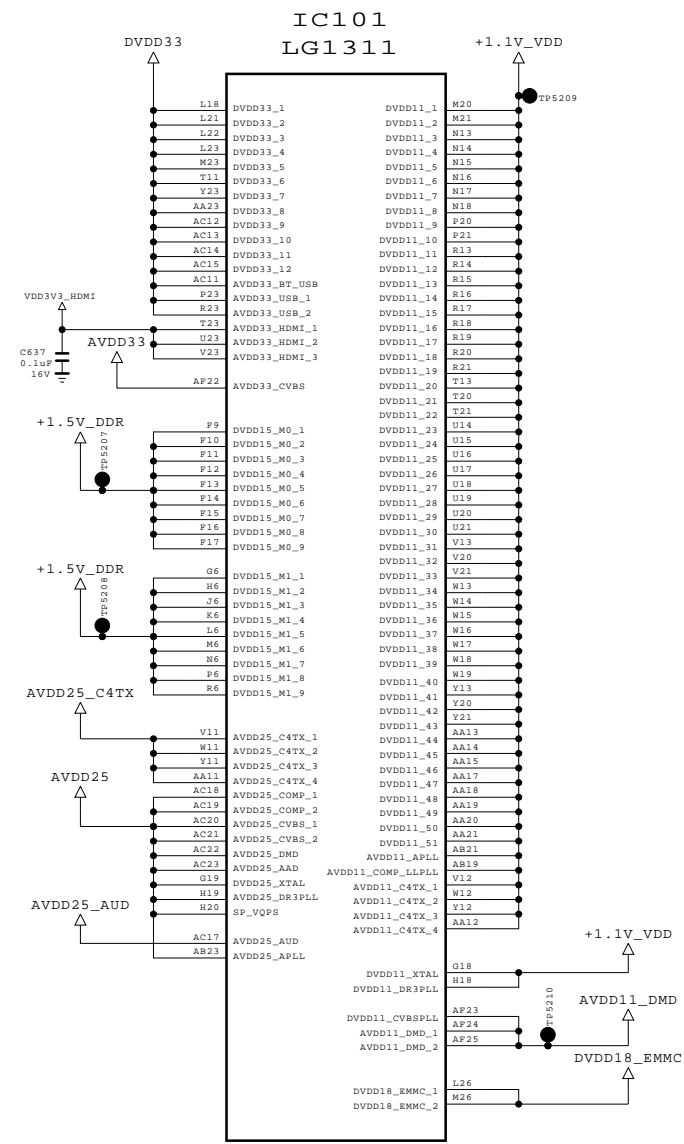

THE Δ SYMBOL MARK OF THIS SCHEMATIC DIAGRAM INCORPORATES SPECIAL FEATURES IMPORTANT FOR PROTECTION FROM X-RADIATION. FIRE AND ELECTRICAL SHOCK HAZARDS, WHEN SERVICING IF IS ESSENTIAL THAT ONLY MANUFACTURERS SPECIFIED PARTS BE USED FOR THE CRITICAL COMPONENTS IN THE Δ SYMBOL MARK OF THE SCHEMATIC.

SECRET
LGElectronics



MODEL	MID_LG1311	DATE	2013.04.04
BLOCK	VCC & GND	SHEET	6 / 31

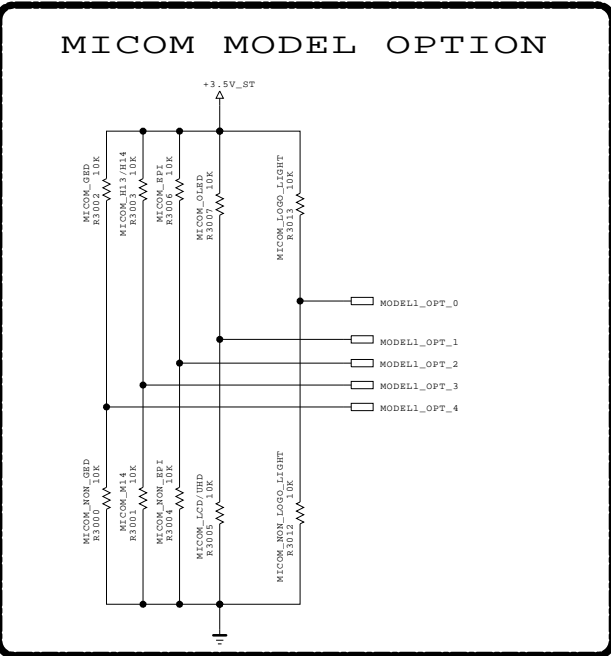
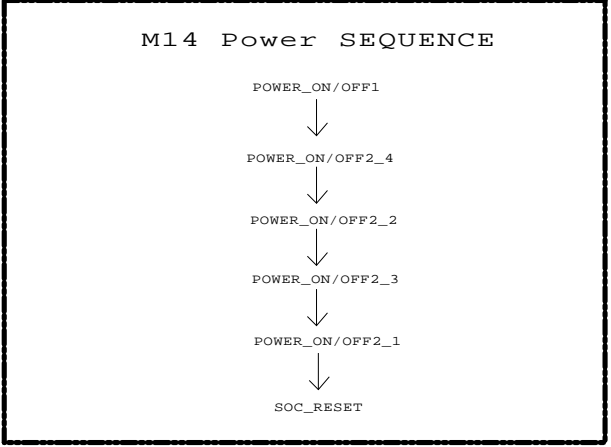
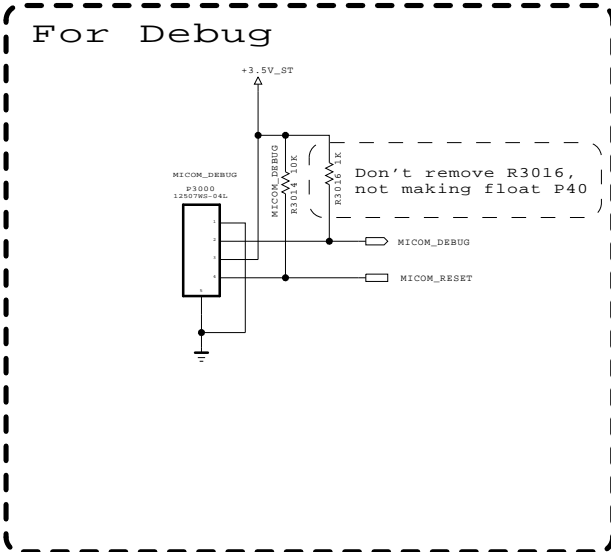

MICOM MODEL OPTION

	0	1
MODEL_OPT_0	NON LOGO	LOGO
MODEL_OPT_1	LCD/UHD	OLED
MODEL_OPT_2	NON_EPI	EPI
MODEL_OPT_3	M14	H13/H14
MODEL_OPT_4	NON_GED	GED

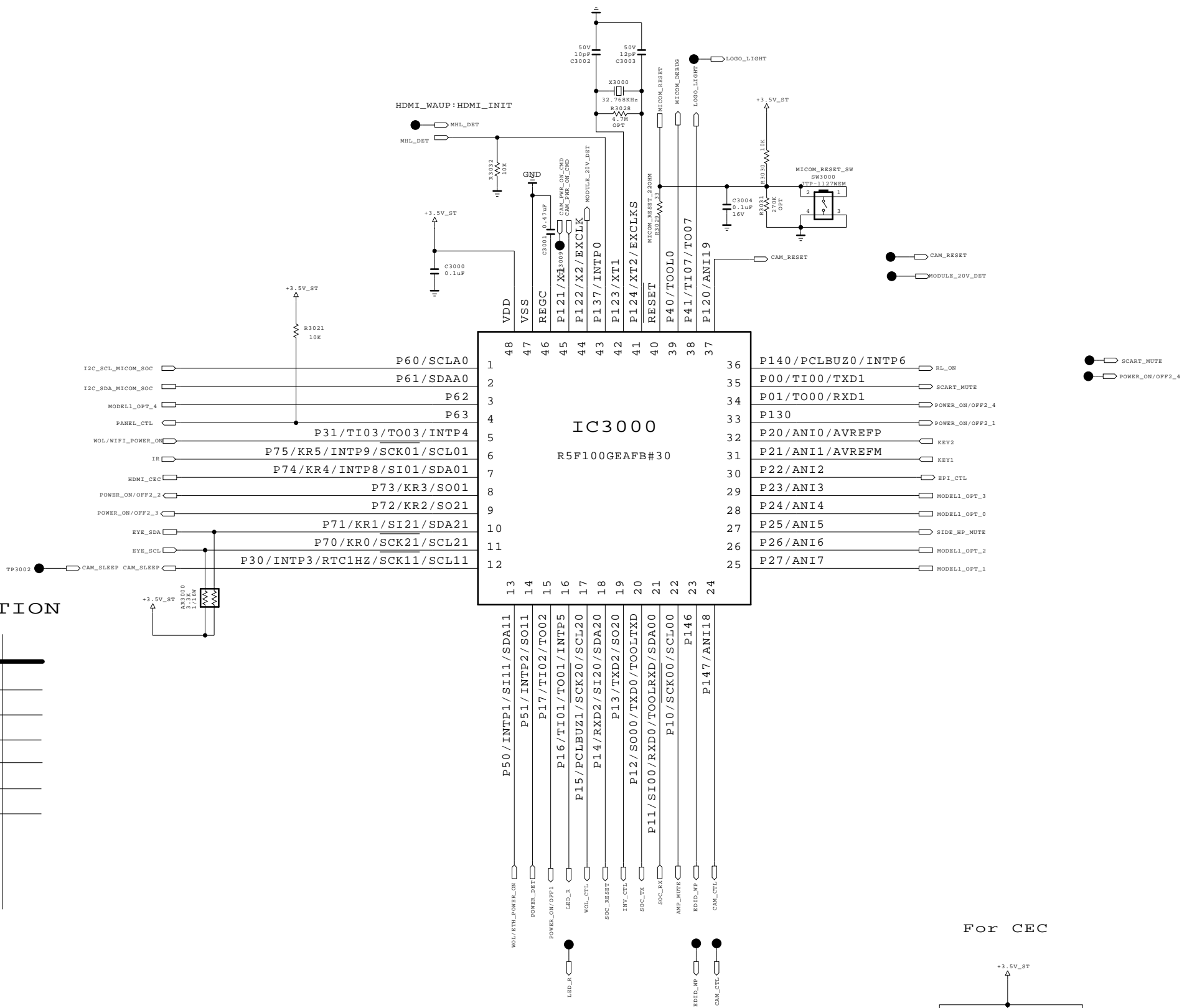

For CEC

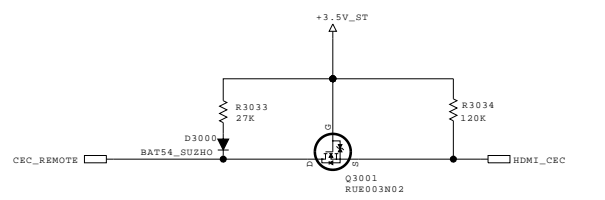

THE SYMBOL MARK OF THIS SCHEMATIC DIAGRAM INCORPORATES SPECIAL FEATURES IMPORTANT FOR PROTECTION FROM X-RADIATION. FIRE AND ELECTRICAL SHOCK HAZARDS, WHEN SERVICING IF IS ESSENTIAL THAT ONLY MANUFACTURERS SPECIFIED PARTS BE USED FOR THE CRITICAL COMPONENTS IN THE SYMBOL MARK OF THE SCHEMATIC.

SECRET
LGElectronics



MODEL	MID_LG1311	DATE	2013.03.22
BLOCK	MICOM	SHEET	9 / 31

SPDIF OUT

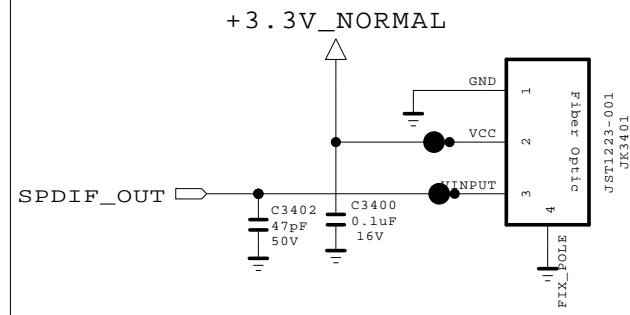

HP OUT

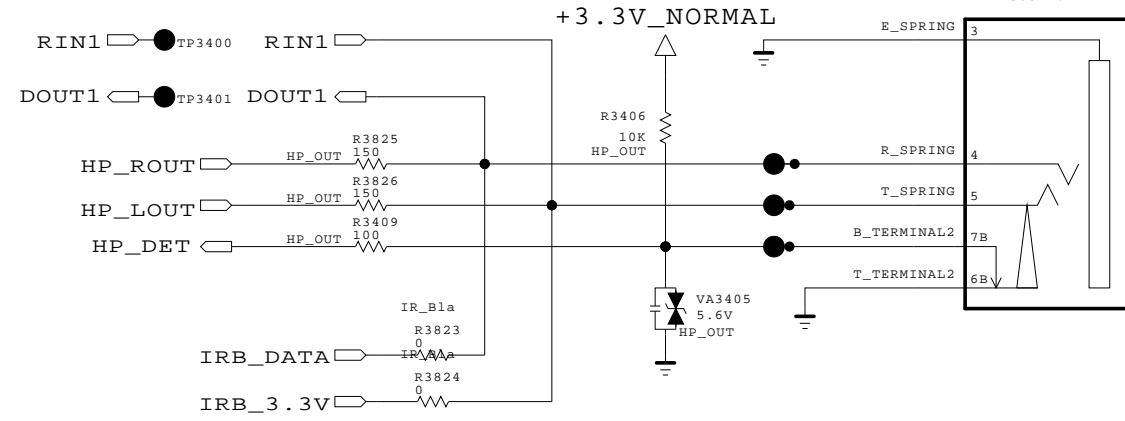

DDTS TEST ONLY

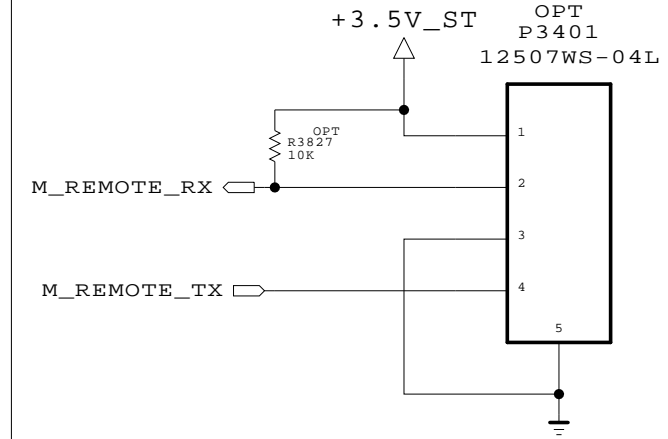

UART for Debug

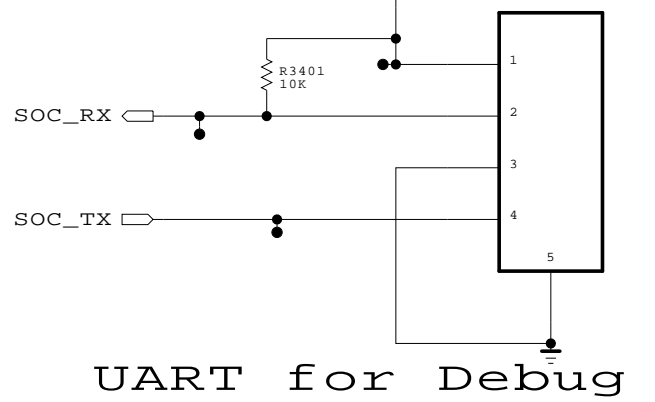

AV/COMPONENT REAR

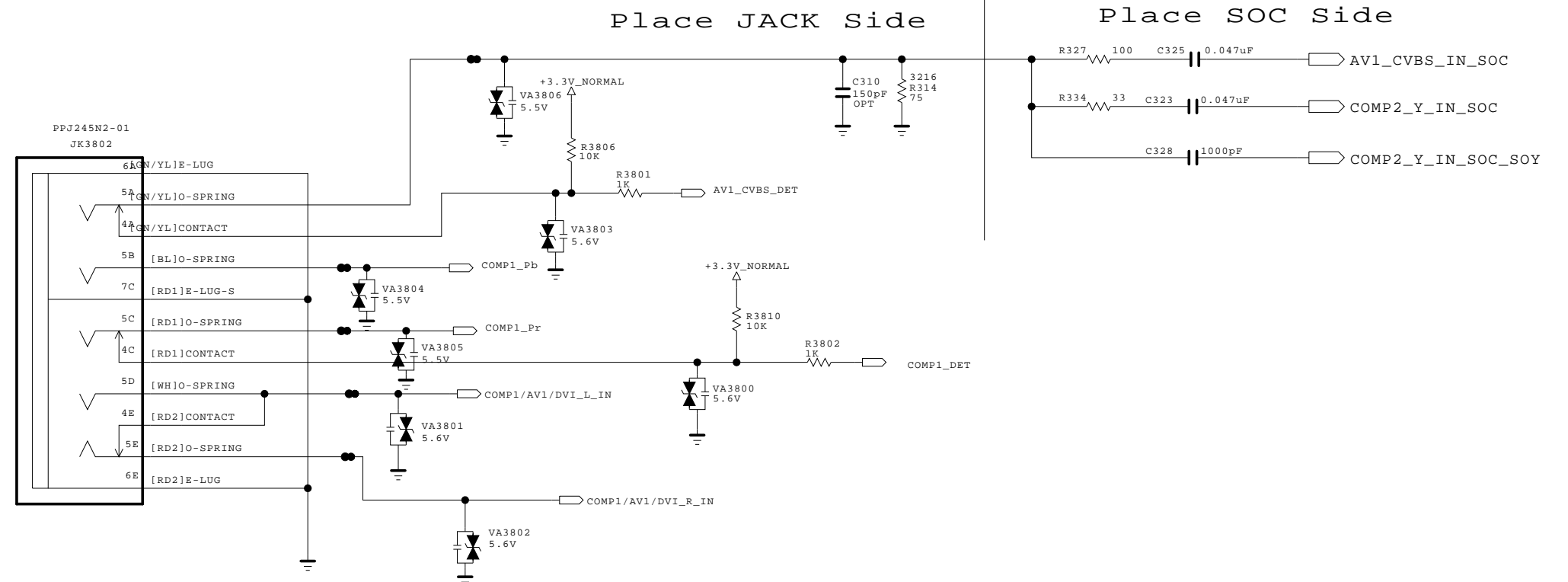

THE SYMBOL MARK OF THIS SCHEMATIC DIAGRAM INCORPORATES SPECIAL FEATURES IMPORTANT FOR PROTECTION FROM X-RADIATION. FIRE AND ELECTRICAL SHOCK HAZARDS, WHEN SERVICING IF IS ESSENTIAL THAT ONLY MANUFACTURERS SPECIFIED PARTS BE USED FOR THE CRITICAL COMPONENTS IN THE SYMBOL MARK OF THE SCHEMATIC.

SECRET	
LG Electronics	

MODEL	MID_LG1311	DATE	2013.04.03
BLOCK	AV JACK	SHEET	11 / 31

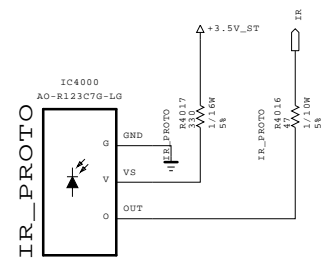
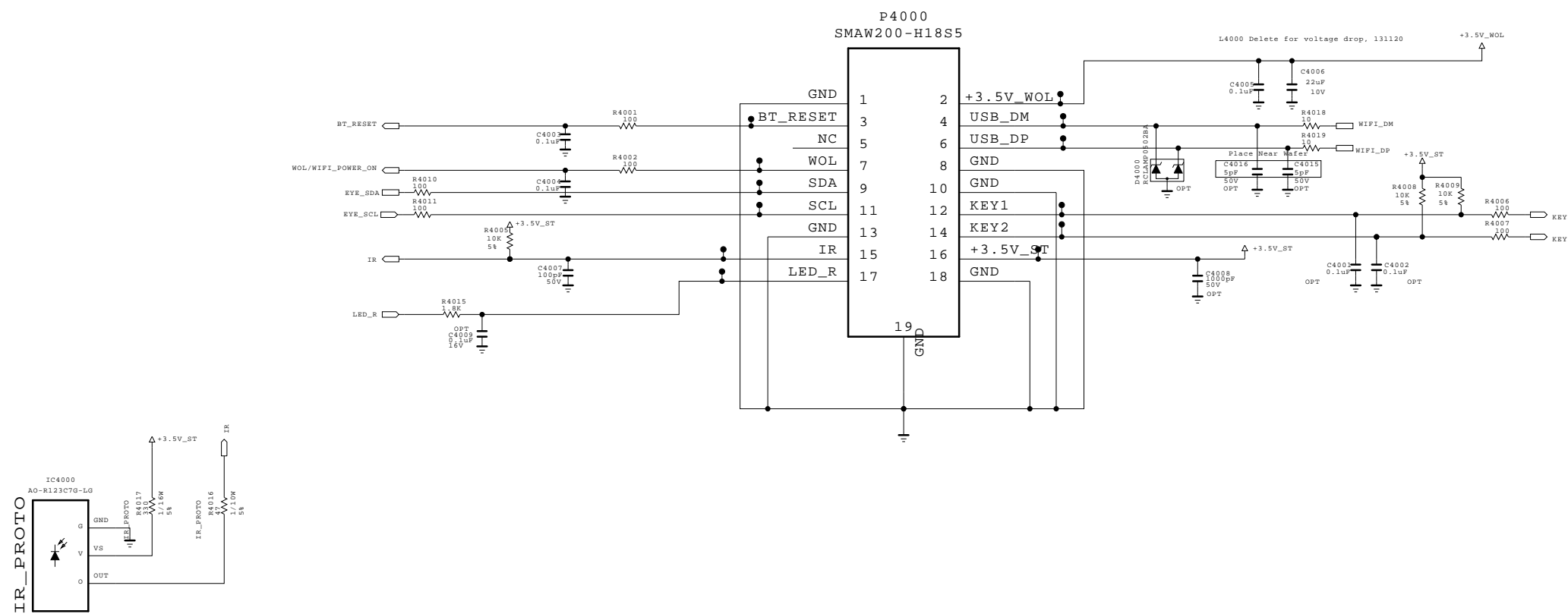

THE SYMBOL MARK OF THIS SCHEMATIC DIAGRAM INCORPORATES SPECIAL FEATURES IMPORTANT FOR PROTECTION FROM X-RADIATION. FIRE AND ELECTRICAL SHOCK HAZARDS, WHEN SERVICING IF IS ESSENTIAL THAT ONLY MANUFACTURERS SPECIFIED PARTS BE USED FOR THE CRITICAL COMPONENTS IN THE SYMBOL MARK OF THE SCHEMATIC.



SECRET
LGElectronics

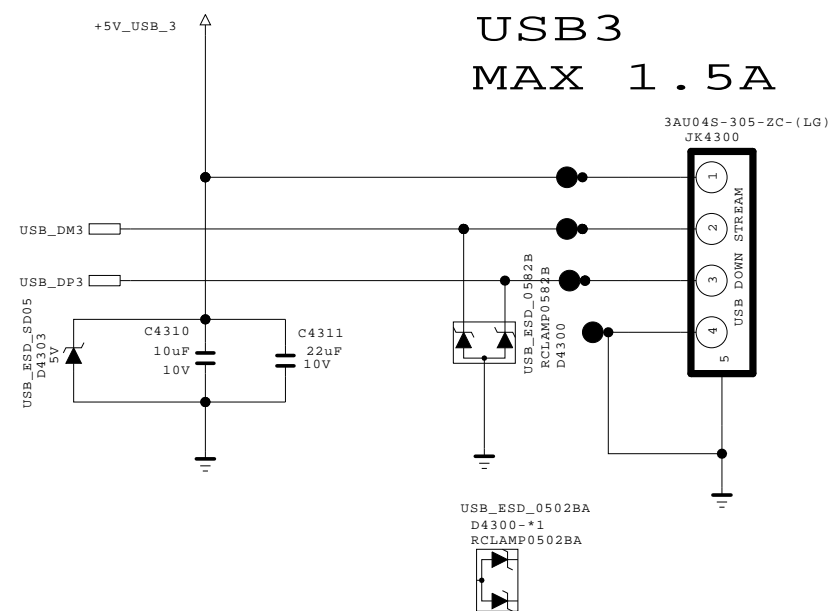
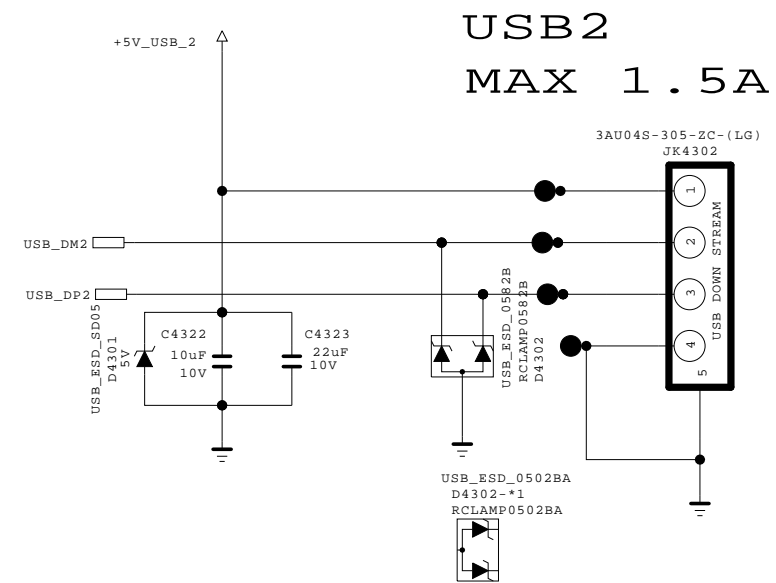

MODEL	MID_LG1311	DATE	2013.03.22
BLOCK	IR / KEY	SHEET	12 / 31



EAX6536390* : Use RClamp0582B, SD05
 EAX6538400* : Use RClamp0502BA

THE  SYMBOL MARK OF THIS SCHEMATIC DIAGRAM INCORPORATES SPECIAL FEATURES IMPORTANT FOR PROTECTION FROM X-RADIATION. FIRE AND ELECTRICAL SHOCK HAZARDS, WHEN SERVICING IF IS ESSENTIAL THAT ONLY MANUFACTURERS SPECIFIED PARTS BE USED FOR THE CRITICAL COMPONENTS IN THE  SYMBOL MARK OF THE SCHEMATIC.

SECRET	 LG ELECTRONICS
LGElectronics	

MODEL	MID_LG1311	DATE	2013.04.03
BLOCK	USB 2 & 3	SHEET	1 /

OCP USB1

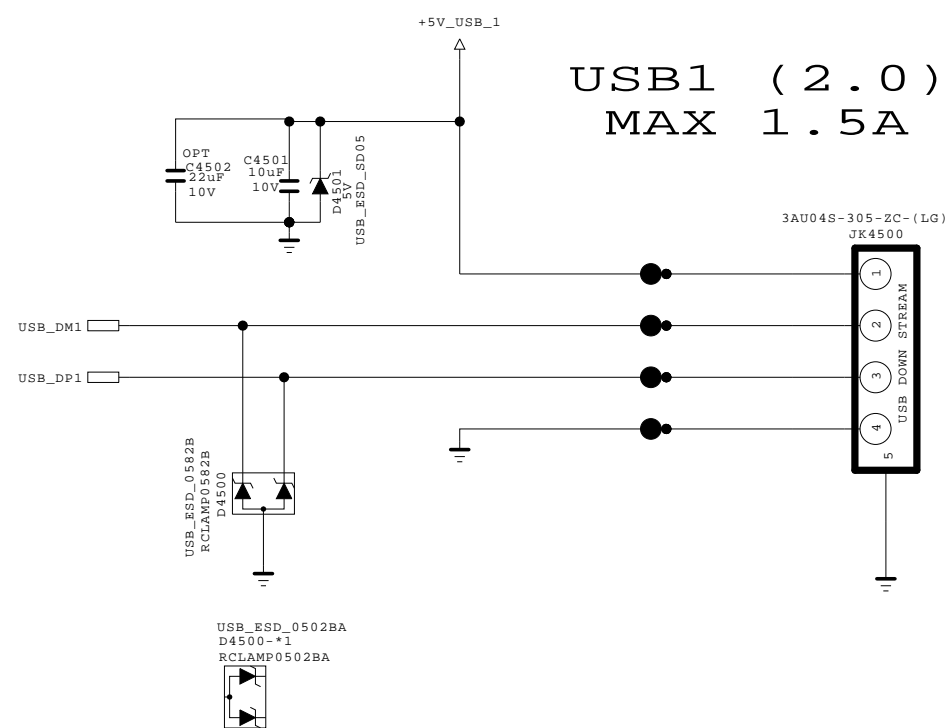
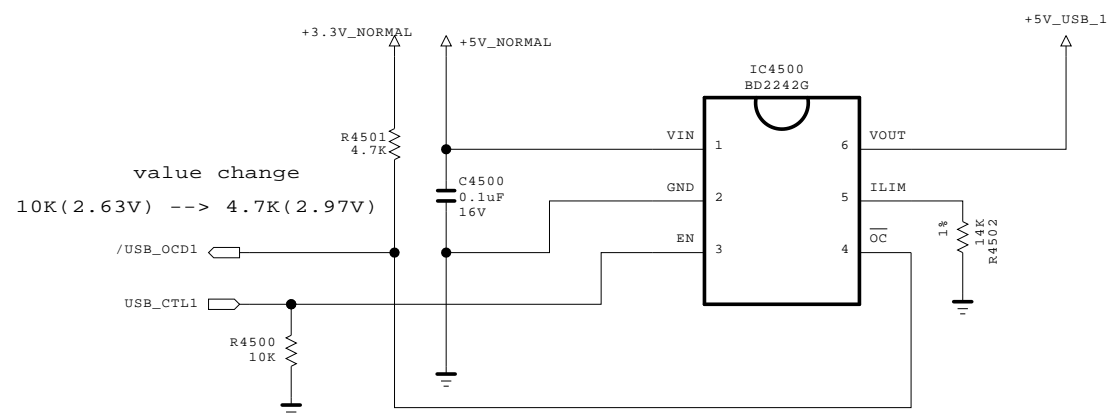

EAX6536390* : Use RClamp0582B, SD05
 EAX6538400* : Use RClamp0502BA

THE SYMBOL MARK OF THIS SCHEMATIC DIAGRAM INCORPORATES SPECIAL FEATURES IMPORTANT FOR PROTECTION FROM X-RADIATION. FIRE AND ELECTRICAL SHOCK HAZARDS, WHEN SERVICING IF IS ESSENTIAL THAT ONLY MANUFACTURERS SPECIFIED PARTS BE USED FOR THE CRITICAL COMPONENTS IN THE SYMBOL MARK OF THE SCHEMATIC.

SECRET	LG ELECTRONICS
LGElectronics	

MODEL	MID_LG1311	DATE	2013.04.03
BLOCK	USB 1(DVR)	SHEET	1 /

Ethernet Block

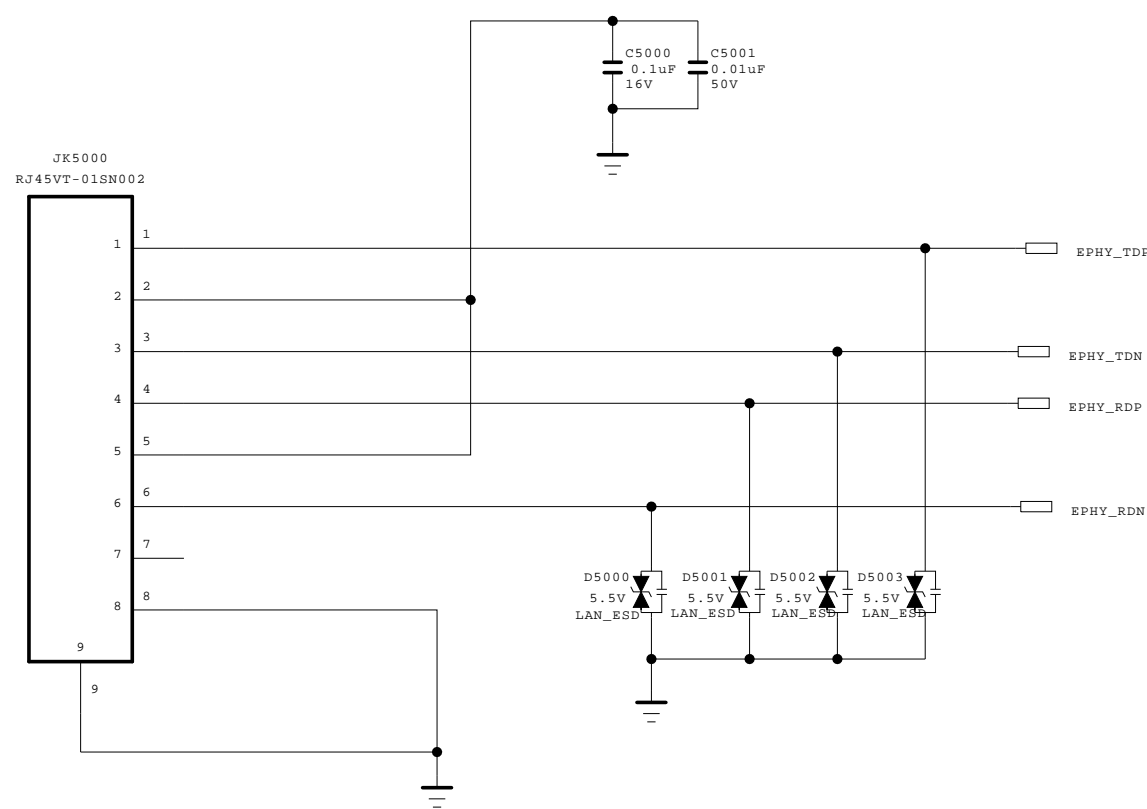

THE SYMBOL MARK OF THIS SCHEMATIC DIAGRAM INCORPORATES SPECIAL FEATURES IMPORTANT FOR PROTECTION FROM X-RADIATION. FIRE AND ELECTRICAL SHOCK HAZARDS, WHEN SERVICING IF IS ESSENTIAL THAT ONLY MANUFACTURERS SPECIFIED PARTS BE USED FOR THE CRITICAL COMPONENTS IN THE SYMBOL MARK OF THE SCHEMATIC.



SECRET
LGElectronics

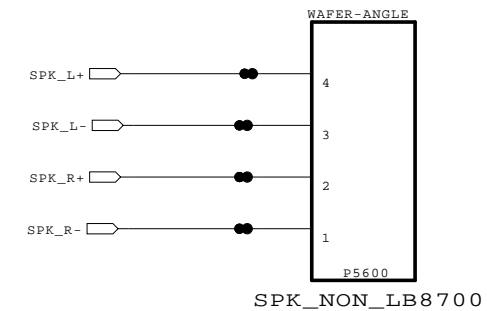
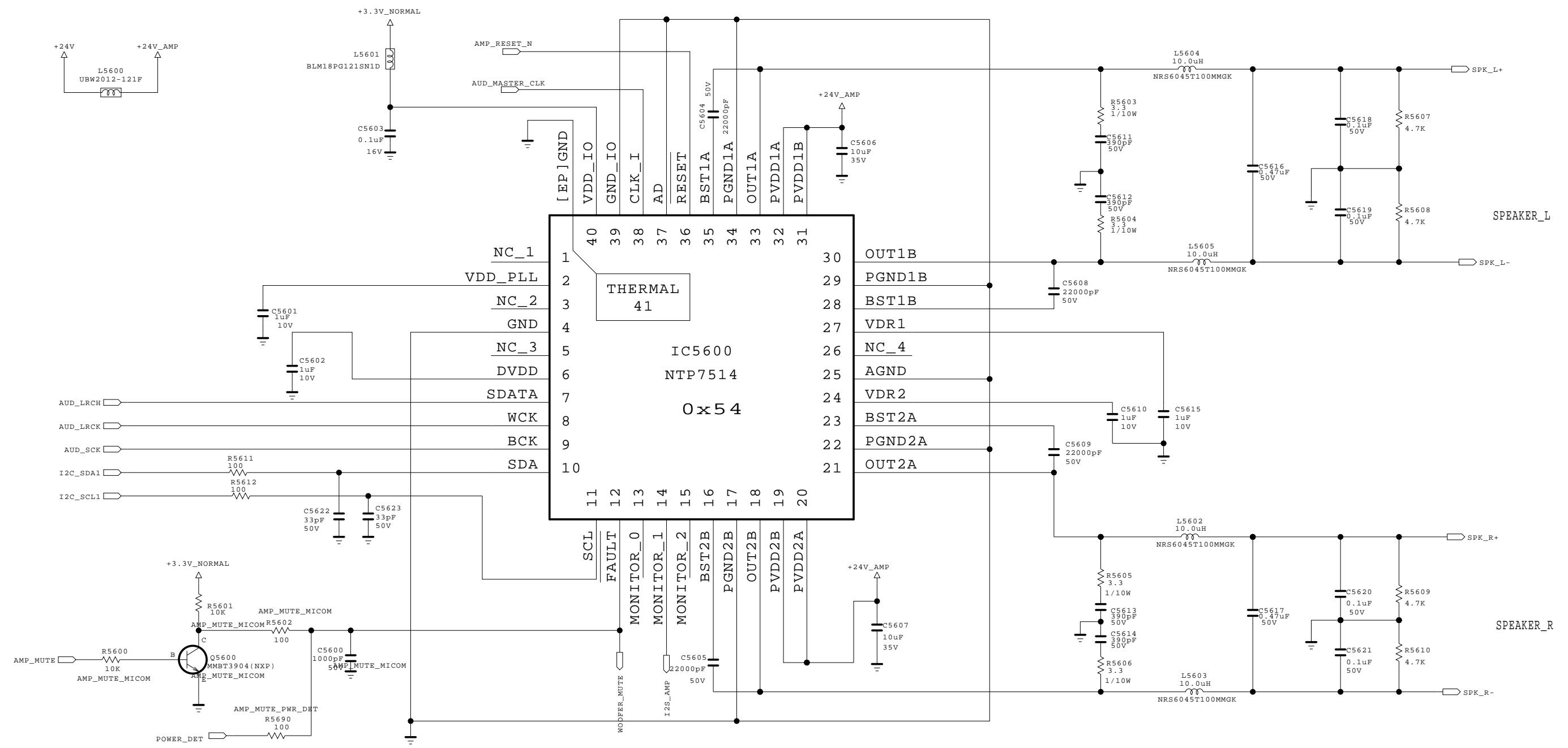

MODEL		DATE	
BLOCK		SHEET	/

AUDIO AMP (NTP7514)



THE  SYMBOL MARK OF THIS SCHEMATIC DIAGRAM INCORPORATES SPECIAL FEATURES IMPORTANT FOR PROTECTION FROM X-RADIATION. FIRE AND ELECTRICAL SHOCK HAZARDS, WHEN SERVICING IF IS ESSENTIAL THAT ONLY MANUFACTURERS SPECIFIED PARTS BE USED FOR THE CRITICAL COMPONENTS IN THE  SYMBOL MARK OF THE SCHEMATIC.

SECRET	 LG ELECTRONICS
LGElectronics	

MODEL	GP4_MT5369	DATE	2011.11.21
BLOCK	AUDIO[ST]	SHEET	58 /

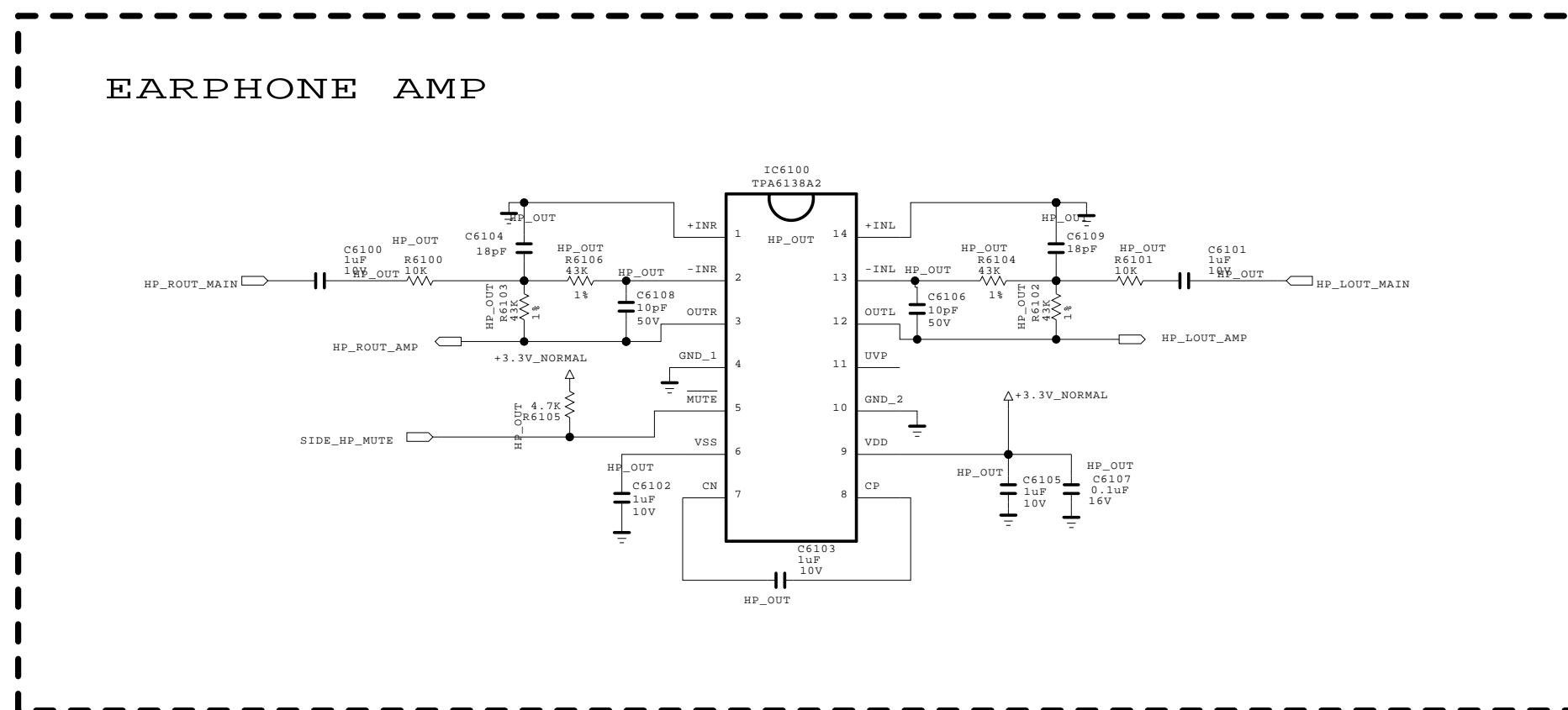

THE SYMBOL MARK OF THIS SCHEMATIC DIAGRAM INCORPORATES SPECIAL FEATURES IMPORTANT FOR PROTECTION FROM X-RADIATION. FIRE AND ELECTRICAL SHOCK HAZARDS, WHEN SERVICING IF IS ESSENTIAL THAT ONLY MANUFACTURERS SPECIFIED PARTS BE USED FOR THE CRITICAL COMPONENTS IN THE SYMBOL MARK OF THE SCHEMATIC.

SECRET
LGElectronics



MODEL	HEADPHONE AMP	DATE	2011.09.29
BLOCK		SHEET	61 /

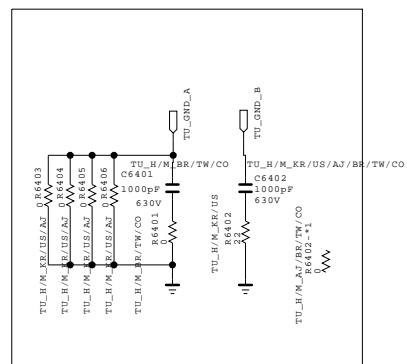
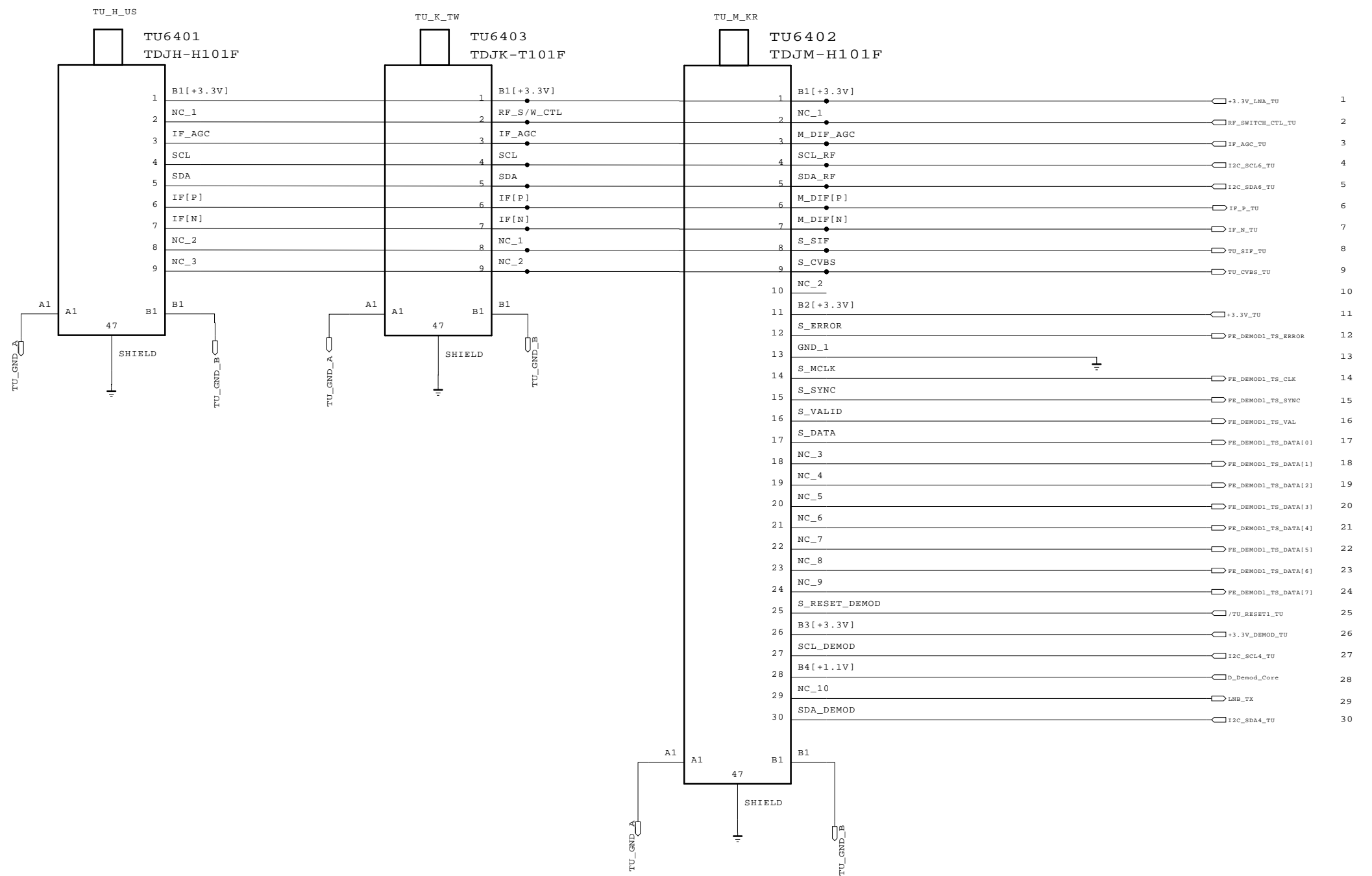
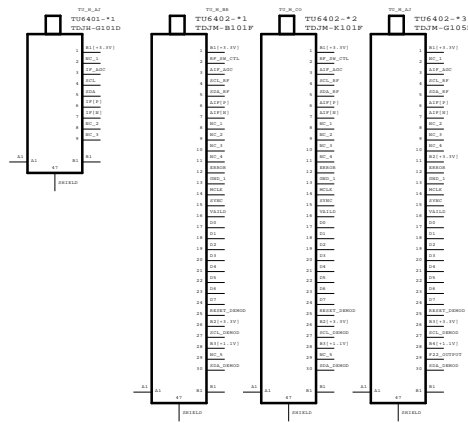

THE SYMBOL MARK OF THIS SCHEMATIC DIAGRAM INCORPORATES SPECIAL FEATURES IMPORTANT FOR PROTECTION FROM X-RADIATION. FIRE AND ELECTRICAL SHOCK HAZARDS, WHEN SERVICING IF IS ESSENTIAL THAT ONLY MANUFACTURERS SPECIFIED PARTS BE USED FOR THE CRITICAL COMPONENTS IN THE SYMBOL MARK OF THE SCHEMATIC.

SECRET
LGElectronics



MODEL	TUNER	DATE	2012.03.08
BLOCK		SHEET	65

○ /TU_RESET2_TU ○ /TU_RESET2
 ● FE_DEMOD1_TS_ERROR

1. should be guarded by ground
2. No via on both of them
3. Signal Width >= 12mils
Signal to Signal Width = 12mils
Ground Width >= 24mils

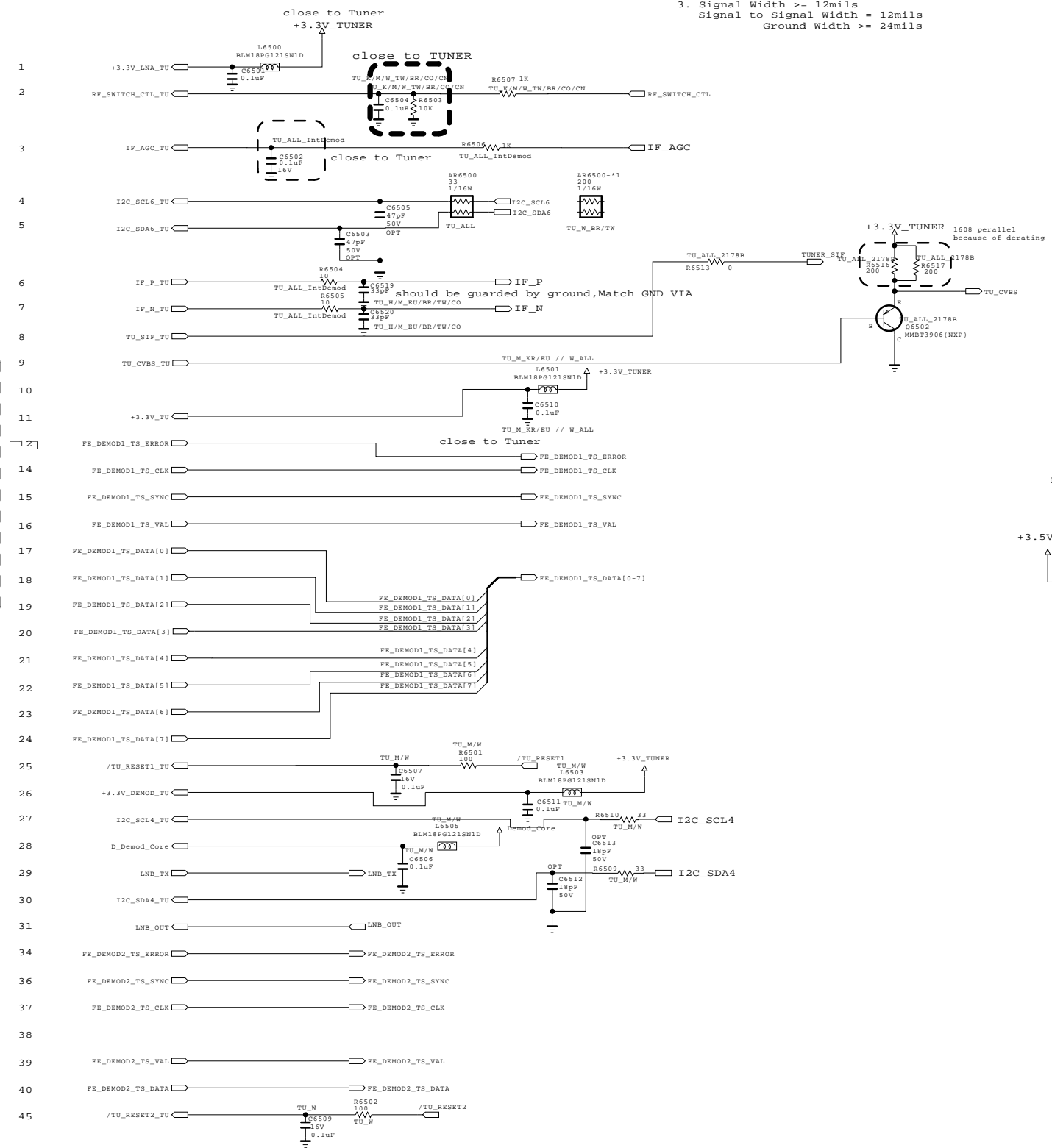

Global F/E Option Name
 1. TU
 2. Tuner Name = TDJ'H',TDJ'M'...
 3. Country Name = KR,US,BR,EU ...

Example of Option name
 TU_ALL_IntDemod = All Tuner type for Internal demod
 TU_M/W = apply TDSM&TDSW Type Tuner

14' Tuner Type for Global
 TDJ'H'-G101D : Half NIM for EU,AJJA
 TDJ'H'-H101F : Half NIM for US, KR
 TDJ'K'-T101F : Half NIM for TW
 TDJ'M'-C301D,F : FULL NIM for China
 TDJ'M'-B101F : Brazil NIM with Isolater Type
 TDJ'M'-K101F : colombia NIM
 TDJ'M'-G101D,G105D,G151D : EU Combo&Full NIM
 TDJ'M'-H101F,H151F : Korea PIP tuner
 TDJ'W'-A151D : AJJA T2 PIP

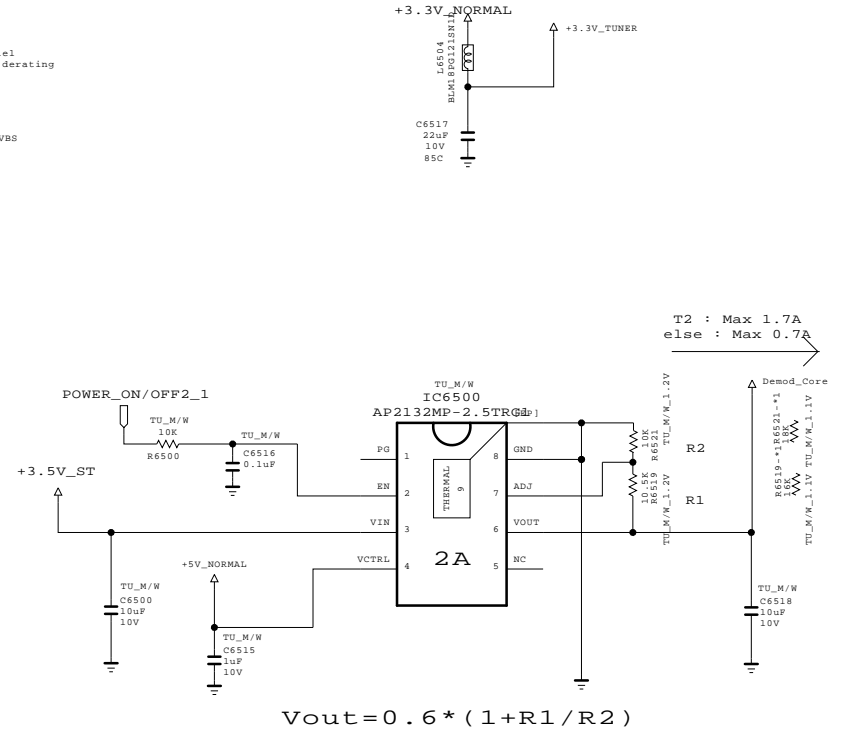

THE SYMBOL MARK OF THIS SCHEMATIC DIAGRAM INCORPORATES SPECIAL FEATURES IMPORTANT FOR PROTECTION FROM X-RADIATION. FIRE AND ELECTRICAL SHOCK HAZARDS, WHEN SERVICING IF IS ESSENTIAL THAT ONLY MANUFACTURERS SPECIFIED PARTS BE USED FOR THE CRITICAL COMPONENTS IN THE SYMBOL MARK OF THE SCHEMATIC.

SECRET
 LGElectronics



MODEL	TUNER	DATE	2012.07.10
BLOCK		SHEET	65

[51Pin LVDS OUTPUT Connector]

[41Pin LVDS OUTPUT Connector]

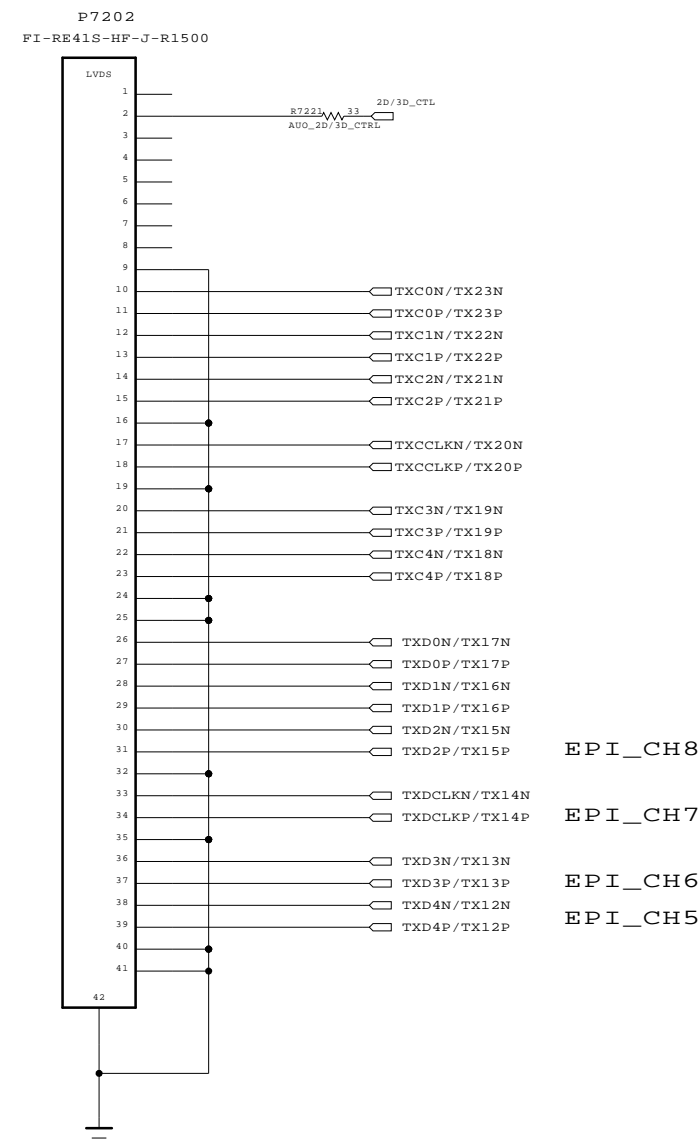
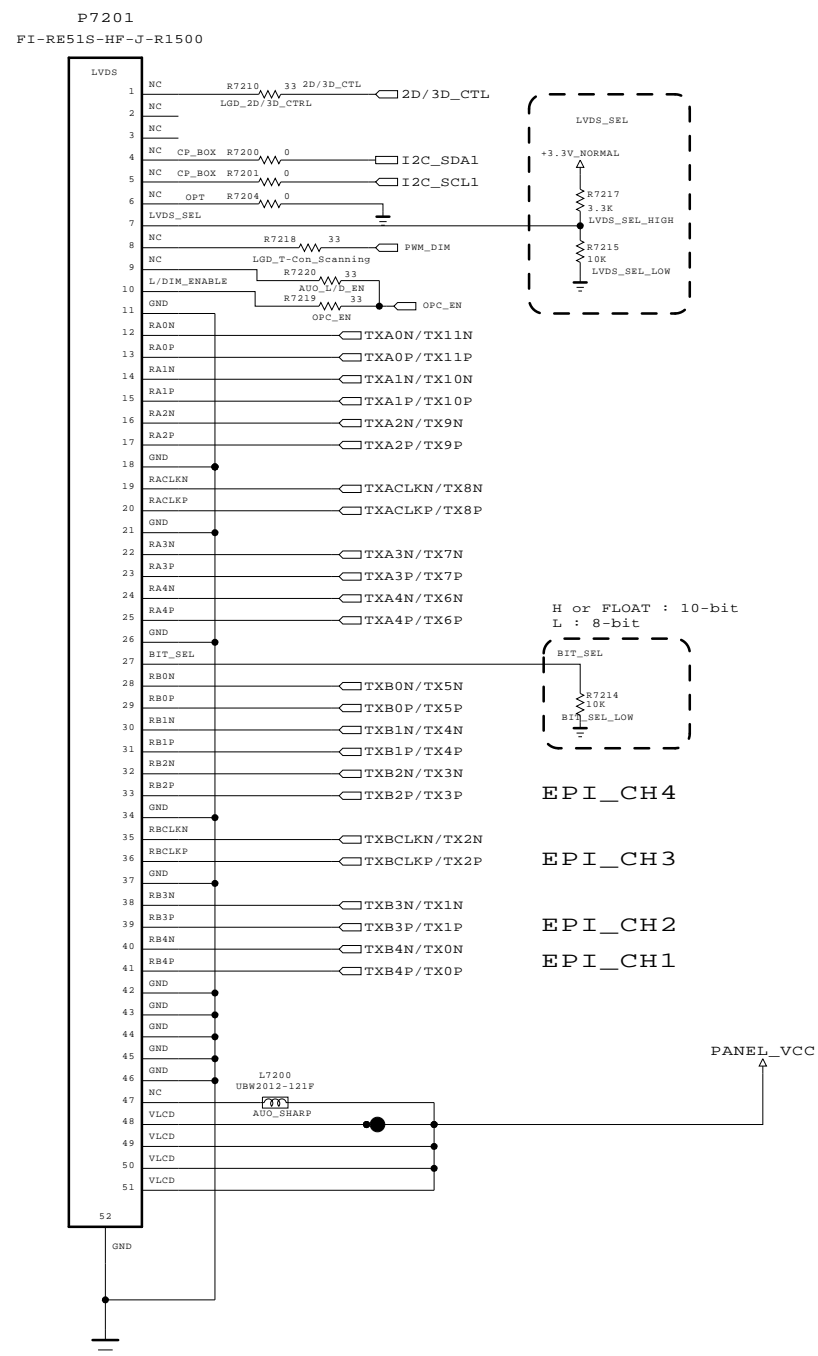

THE SYMBOL MARK OF THIS SCHEMATIC DIAGRAM INCORPORATES SPECIAL FEATURES IMPORTANT FOR PROTECTION FROM X-RADIATION. FIRE AND ELECTRICAL SHOCK HAZARDS, WHEN SERVICING IF IS ESSENTIAL THAT ONLY MANUFACTURERS SPECIFIED PARTS BE USED FOR THE CRITICAL COMPONENTS IN THE SYMBOL MARK OF THE SCHEMATIC.

SECRET
LGElectronics



BSD-NC4_H072-HD			
MODEL	MID_LG1311	DATE	2013.04.03
BLOCK	LVDS INTERFACE	SHEET	/

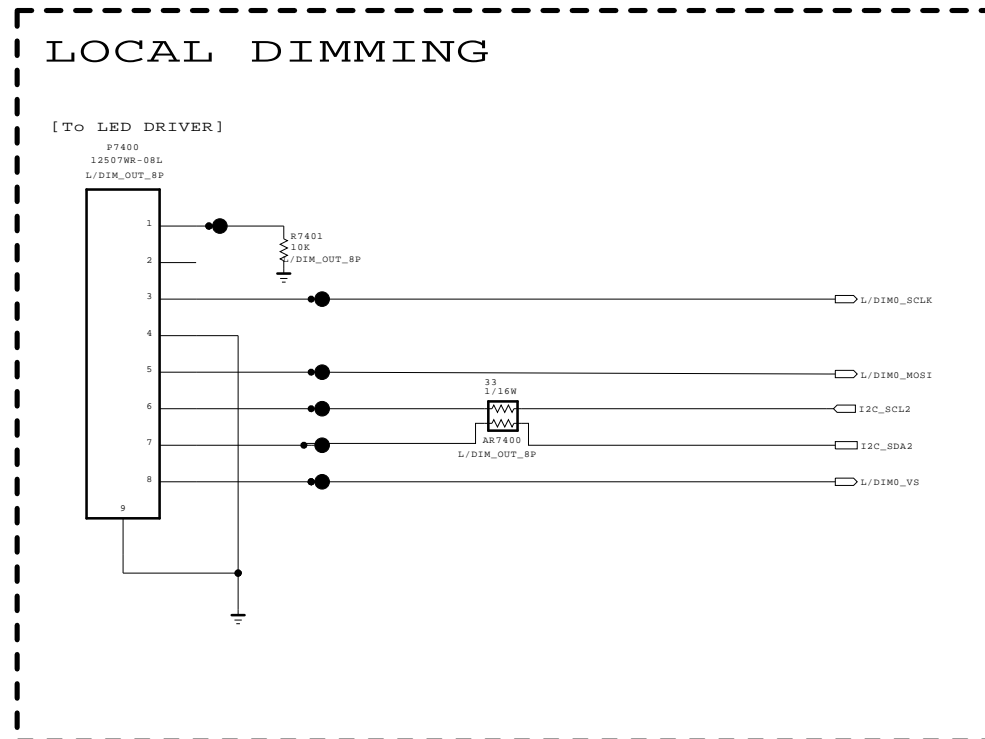

THE SYMBOL MARK OF THIS SCHEMATIC DIAGRAM INCORPORATES SPECIAL FEATURES IMPORTANT FOR PROTECTION FROM X-RADIATION. FIRE AND ELECTRICAL SHOCK HAZARDS, WHEN SERVICING IT IS ESSENTIAL THAT ONLY MANUFACTURERS SPECIFIED PARTS BE USED FOR THE CRITICAL COMPONENTS IN THE SYMBOL MARK OF THE SCHEMATIC.

SECRET
LGElectronics



BSD-NC4_H074-HD

MODEL	LOCAL DIMMING	DATE	2012.09.14
BLOCK		SHEET	/

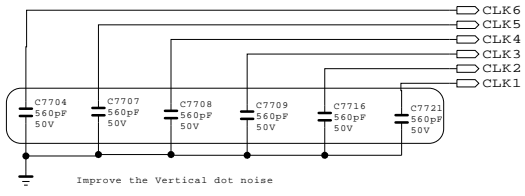

V14-LGD PANEL

EPI 8-Lane (LEFT)

EPI 8-Lane (RIGHT)

P7702
FL11S050HA1

P7703
FL11S050HA1

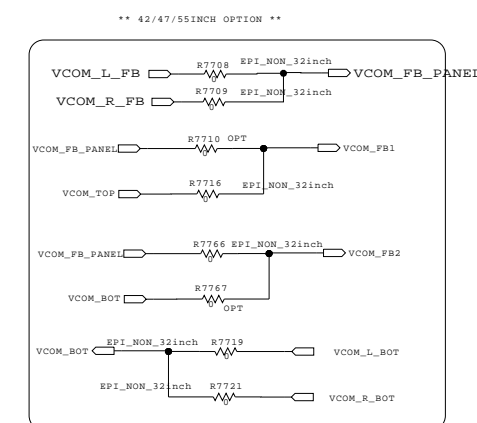
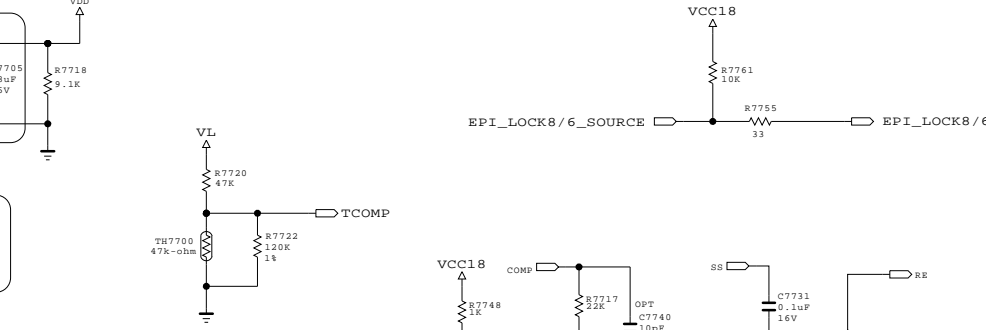
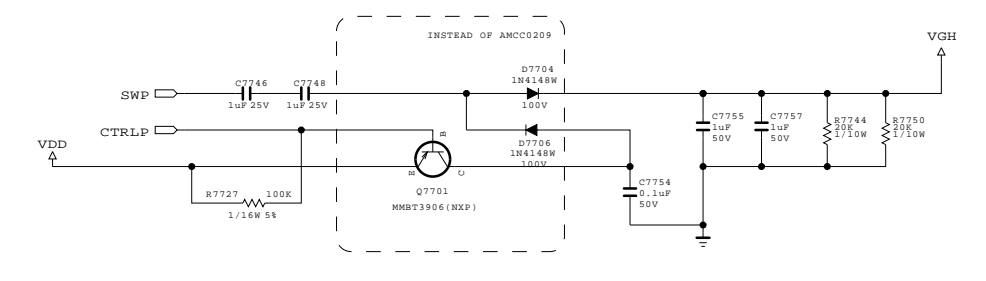
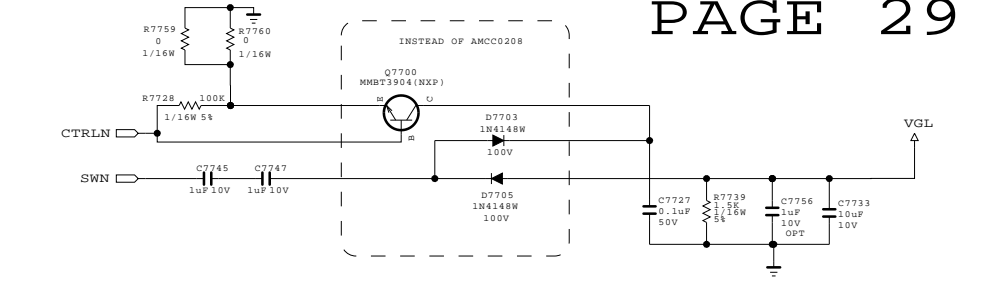
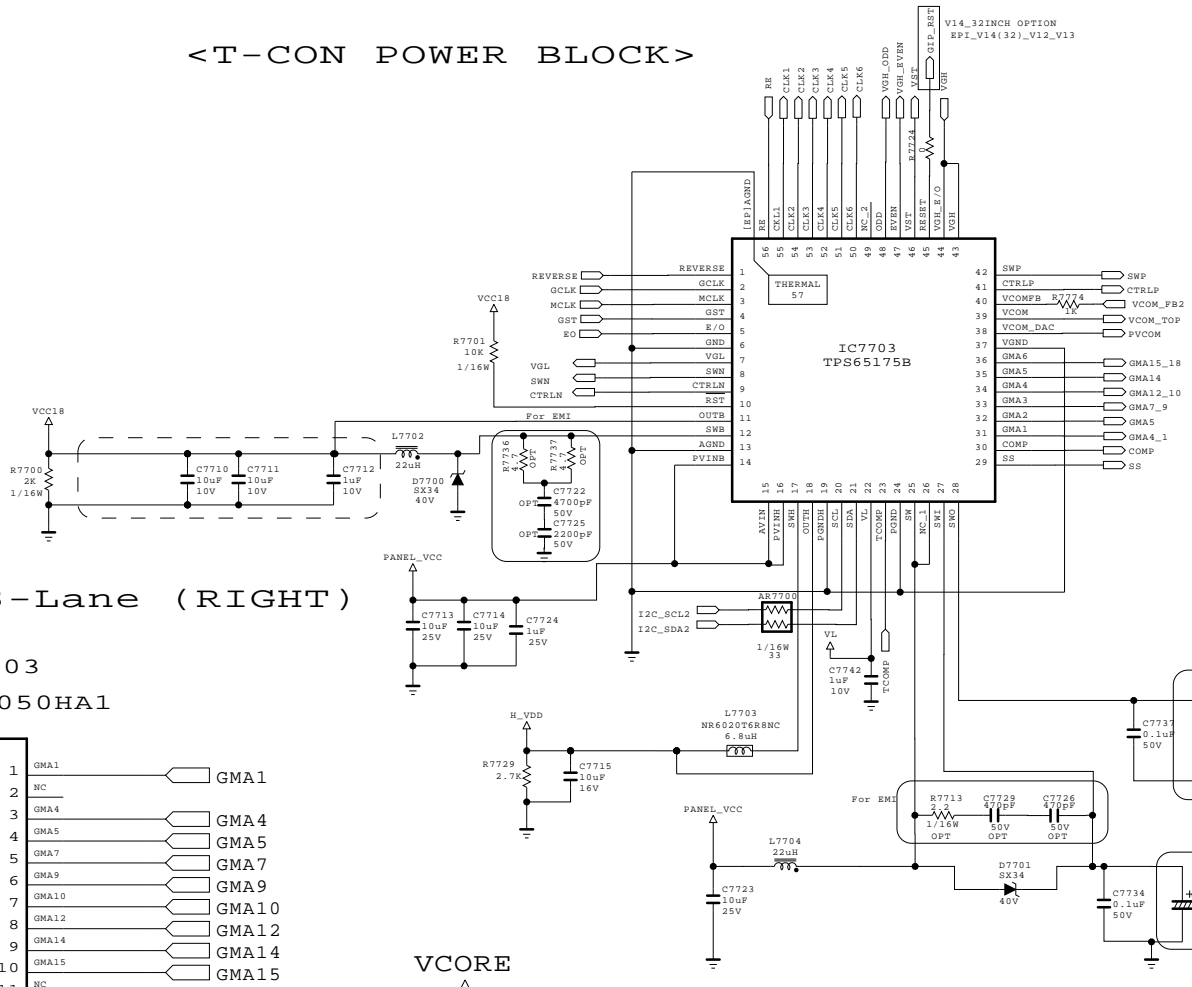
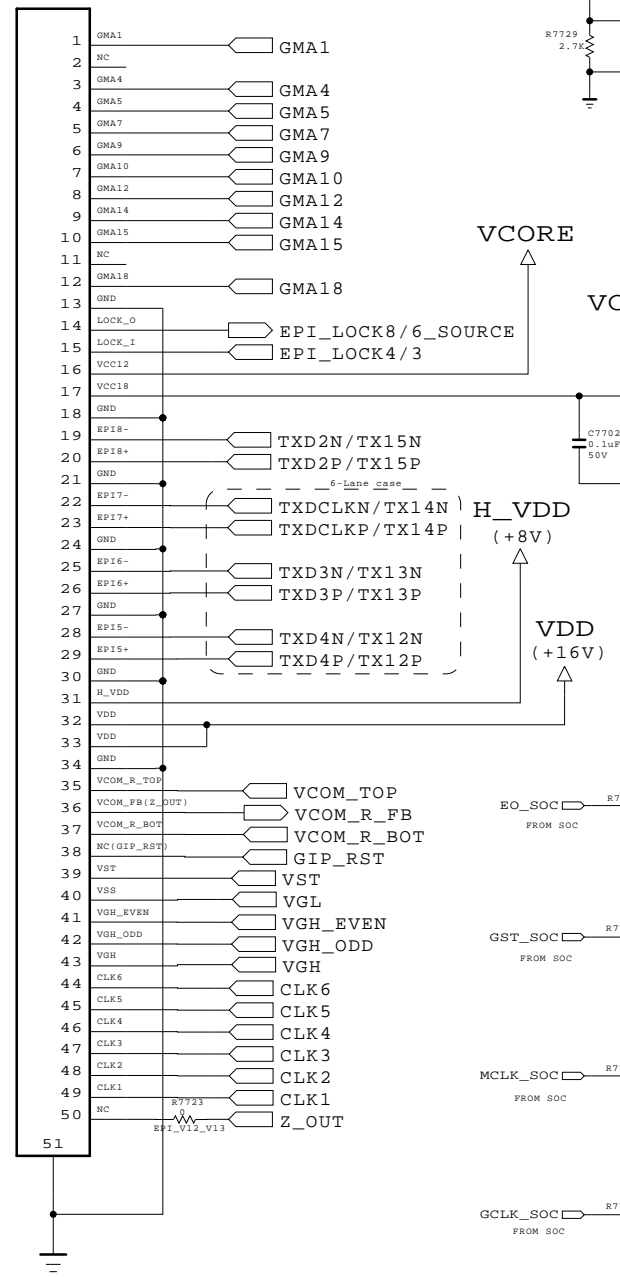
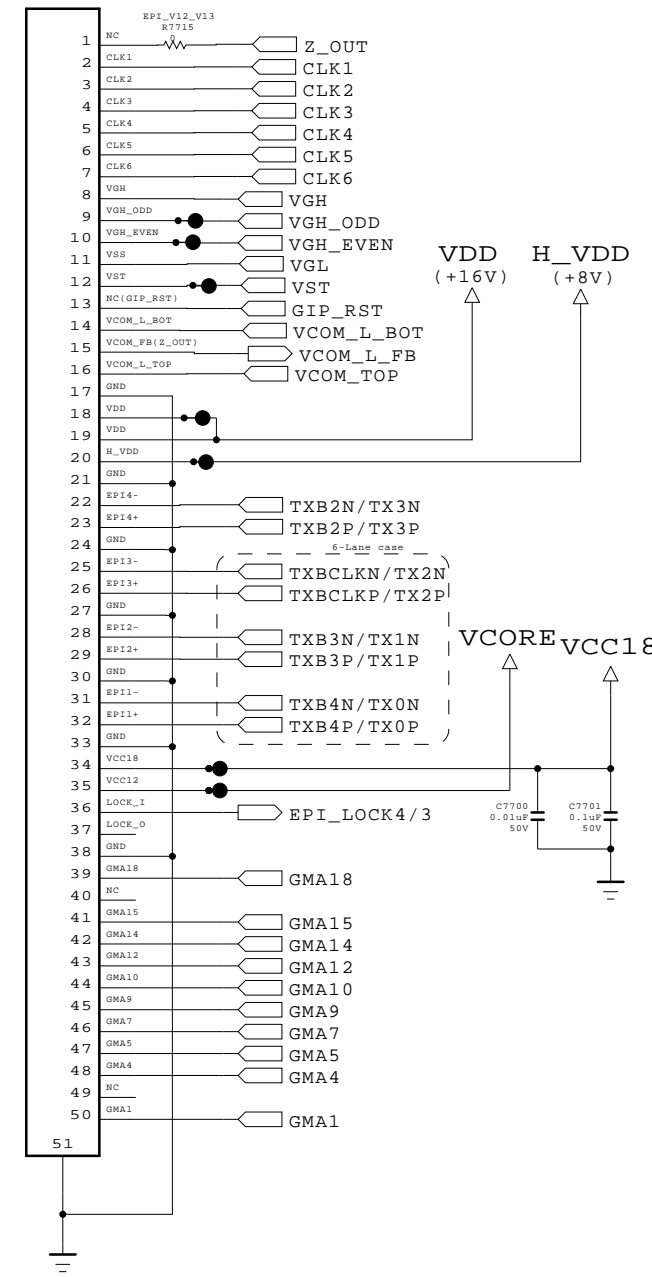

< VCOM OPTION TABLE >

V14 42-55INCH				V14 32INCH			
EXT.OP AMP NOT USE	EXT.OP AMP USE	EXT.OP AMP NOT USE	EXT.OP AMP USE	EXT.OP AMP NOT USE	EXT.OP AMP USE	EXT.OP AMP NOT USE	EXT.OP AMP USE
IC7702 NC	R7716 0 ohm	IC7702 USE	R7710 0 ohm	IC7702 NC	IC7702 USE		
C7760 NC	R7766 0 ohm	C7760 USE	R7716 NC	C7760 NC	C7760 USE		
L7706 NC	R7767 NC	L7706 USE	R7766 0 ohm	L7706 NC	L7706 USE		
R7770 0 ohm	R7719 0 ohm	R7770 1kohm	R7767 NC	R7770 NC	R7770 1kohm		
R7772 0 ohm	R7721 0 ohm	R7771 0 ohm	R7719 0 ohm	R7771 NC	R7771 0 ohm		
R7708 0 ohm	R7771 NC	R7772 30kohm	R7721 0 ohm	R7772 NC	R7772 30kohm		
R7705 0 ohm		R7708 0 ohm		R7702 0 ohm	R7702 0 ohm		
R7710 NC		R7709 0 ohm		R7707 0 ohm	R7707 0 ohm		
				R7711 0 ohm	R7711 0 ohm		
				R7712 NC	R7712 0 ohm		
				R7714 NC	R7714 0 ohm		

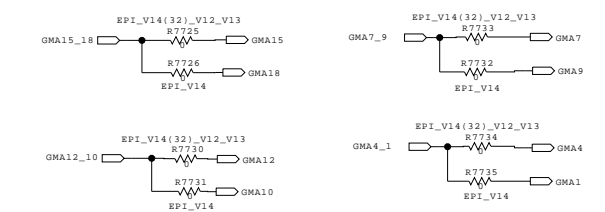
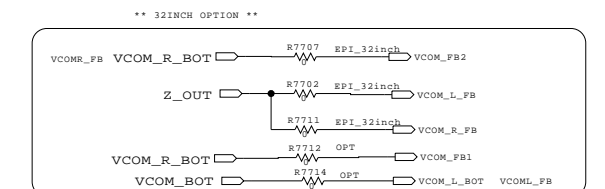

THE SYMBOL MARK OF THIS SCHEMATIC DIAGRAM INCORPORATES SPECIAL FEATURES IMPORTANT FOR PROTECTION FROM X-RADIATION. FIRE AND ELECTRICAL SHOCK HAZARDS, WHEN SERVICING IT IS ESSENTIAL THAT ONLY MANUFACTURERS SPECIFIED PARTS BE USED FOR THE CRITICAL COMPONENTS IN THE SYMBOL MARK OF THE SCHEMATIC.

SECRET
LGElectronics



MODEL	MID_LG1311	DATE	2013.04.03
BLOCK	T-Con	SHEET	77

eMMC I/F

* A0 / A1 : Use EMMC_4.41
 * B0 : Use EMMC_4.5
 (130923_Jihwan Hyun)

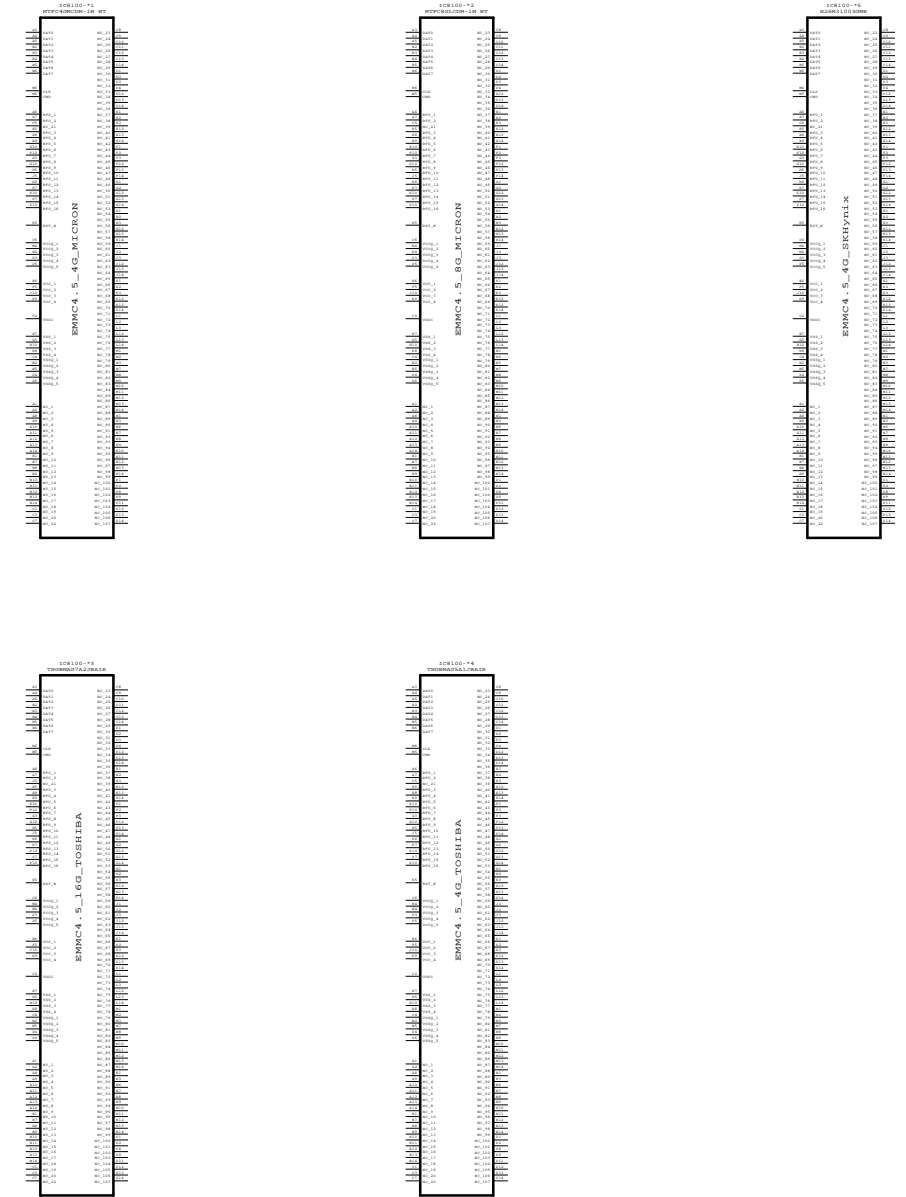
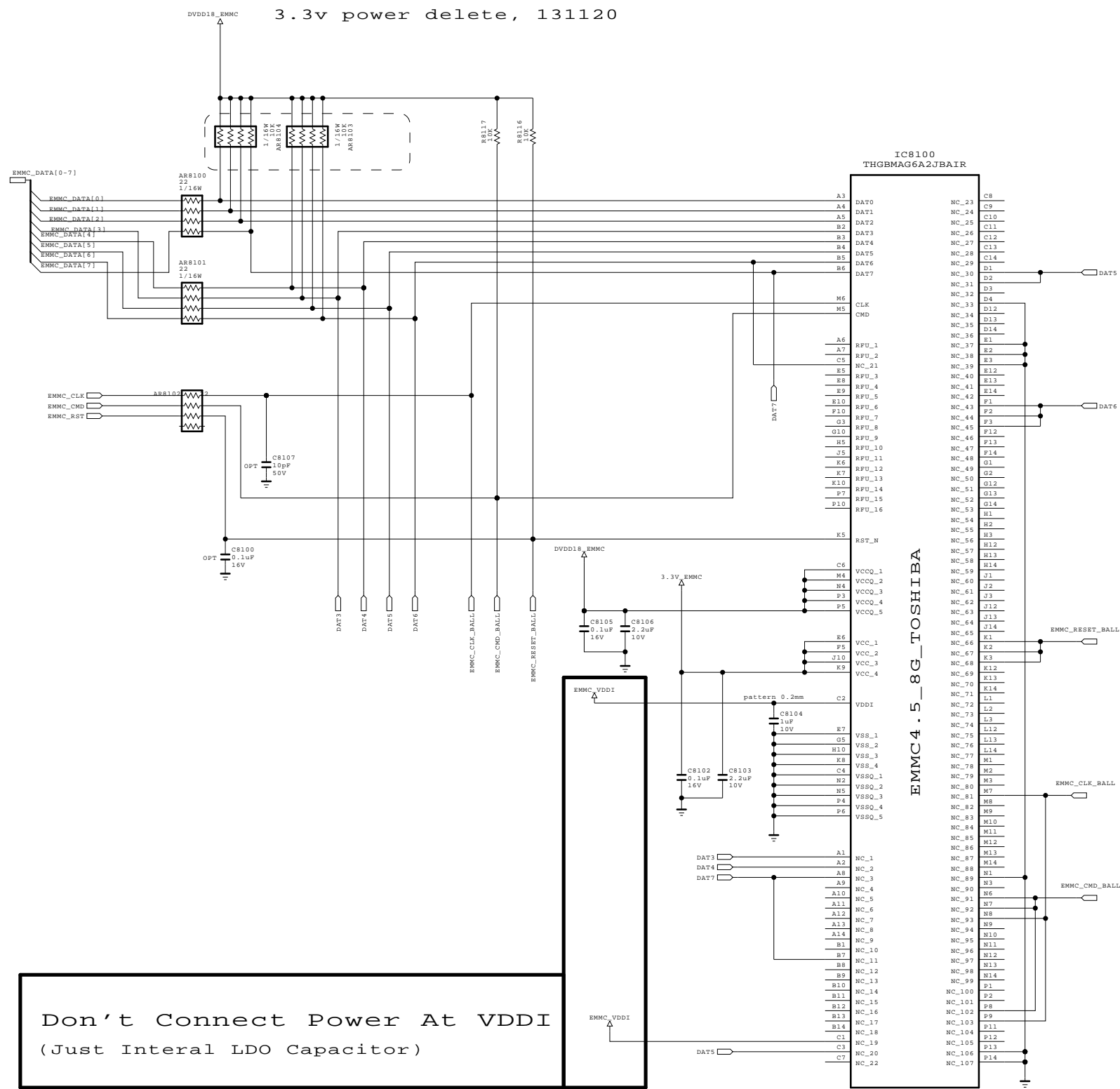

Don't Connect Power At VDDI
 (Just Internal LDO Capacitor)

THE Δ SYMBOL MARK OF THIS SCHEMATIC DIAGRAM INCORPORATES SPECIAL FEATURES IMPORTANT FOR PROTECTION FROM X-RADIATION. FIRE AND ELECTRICAL SHOCK HAZARDS, WHEN SERVICING IF IS ESSENTIAL THAT ONLY MANUFACTURERS SPECIFIED PARTS BE USED FOR THE CRITICAL COMPONENTS IN THE Δ SYMBOL MARK OF THE SCHEMATIC.

SECRET
 LGElectronics



MODEL	eMMC	DATE	11.09.29
BLOCK		SHEET	81

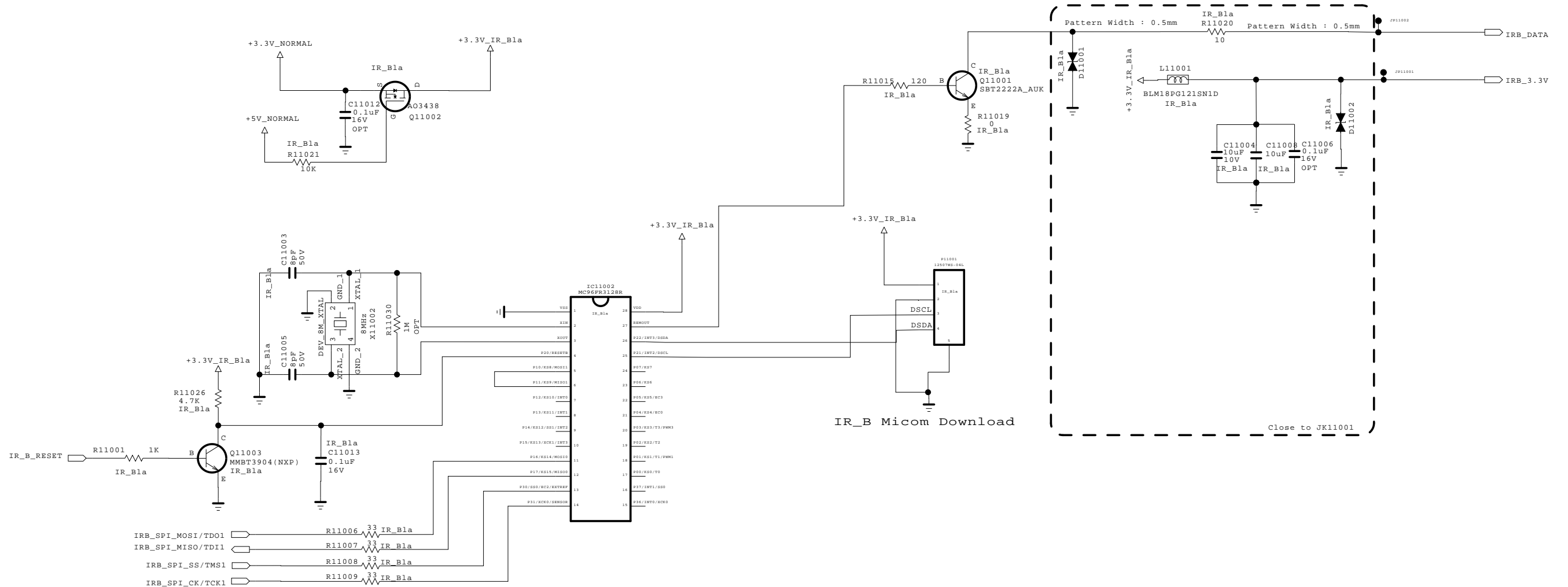

THE ⚠ SYMBOL MARK OF THIS SCHEMATIC DIAGRAM INCORPORATES SPECIAL FEATURES IMPORTANT FOR PROTECTION FROM X-RADIATION. FIRE AND ELECTRICAL SHOCK HAZARDS, WHEN SERVICING IF IS ESSENTIAL THAT ONLY MANUFACTURERS SPECIFIED PARTS BE USED FOR THE CRITICAL COMPONENTS IN THE ⚠ SYMBOL MARK OF THE SCHEMATIC.

SECRET	
LGElectronics	

MODEL	MID_LG1311	DATE	2013.04.02
BLOCK	IR Blaster/Boost	SHEET	110 /

RS-232 Control INTERFACE

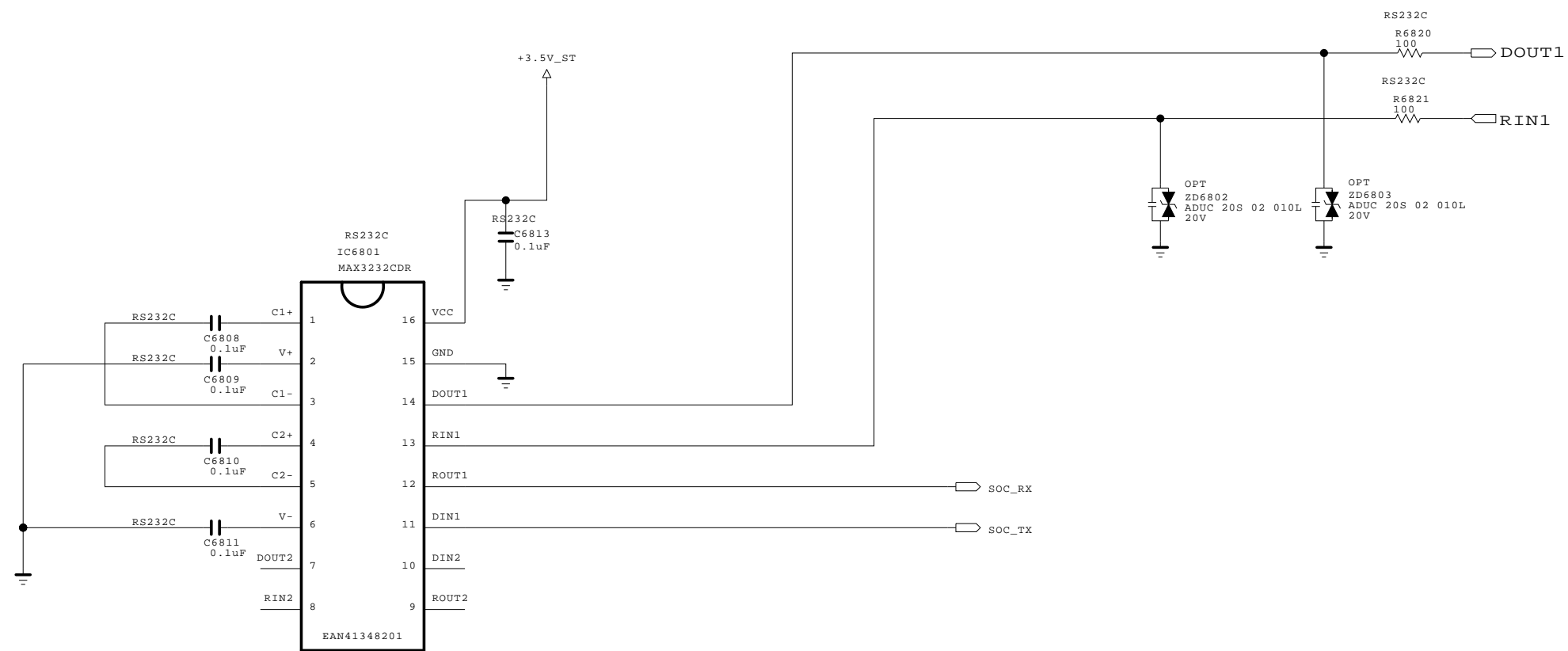

THE SYMBOL MARK OF THIS SCHEMATIC DIAGRAM INCORPORATES SPECIAL FEATURES IMPORTANT FOR PROTECTION FROM X-RADIATION. FIRE AND ELECTRICAL SHOCK HAZARDS, WHEN SERVICING IF IS ESSENTIAL THAT ONLY MANUFACTURERS SPECIFIED PARTS BE USED FOR THE CRITICAL COMPONENTS IN THE SYMBOL MARK OF THE SCHEMATIC.

SECRET
LGElectronics

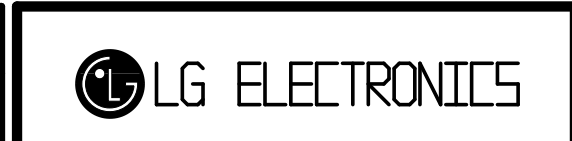

MODEL		DATE	
BLOCK		SHEET	/



2014 LED/LCD TV Engineering guide

< Applicable Model – Mid end >

55LB7200

70/65/60LB7100

60/55/50/47/42LB6500

65/60/55/47/42LB6300

◆ CONTENT ◆

- 1. '2014 Product line-up and features**
- 2. Model naming and tool option**
- 3. New features**
- 4. Main PCBs**
- 5. Block Diagrams, IIC Map**
- 6. Structure of TV set and connection of sub assy's**
- 7. New sub assy's**
 - Instruction of new sub assy's**
 - How to use tool**
 - Download**
- 8. Repair guide**

◆ CONTENT ◆

1. '2014 Product line-up and features

2. Model naming and tool option

3. New features

4. Main PCBs

5. Block Diagrams, IIC Map

6. Structure of TV set and connection of sub assy's

7. New sub assy's

- Instruction of new sub assy's

- How to use tool

- Download

8. Repair guide

		Series	ATS	Inch				Feature													
OLED E	High	EC9800	6/30W		77				UHD	H13 (U14)	C/S	3D	webOS	Magic							
		EC9700	9/22W		65																
		EC9300	6/02W(Set Air 기준)			55			FHD	H13	Gallery	NC 4.0									
		EA9800	Garry-over			55															
		EA8800	(2월3주) Gallery			55															
ULTRA HD U	High	UC9	11/24W	New form factor	105	8/11W	5/12W	4/28W	5/05W	240Hz	U14	Case Top	3D	webOS							
		UB9800	4/28W	Premium UHD		98	84	79	65												
		UB9500	6/16W	Basic UHD			65		55	240Hz	H13	C/S	3D	NC4.5							
		UB9300	6/23W	Basic, Smart Only			65														
		UC8900(9400)	8/25W	Curved(AUO)			65			120Hz	LM14	C/S	3D	S-Con							
		UB8500	5/05W	UHD Hit, H13			60	55	49												
		UB8300	8/11W	엮가형 Hit Model (3D&Smart)			7월(TBD)		55	49											
		UB8200	(9월-TBD)	엮가형 Hit Model (Smart Only)					8/11W	9/08W				42							
LED	High	LB7200	3/17W			3/24W	5/12W	3/31W	55	240Hz	M14	3D	webOS	Magic							
		LB7100	3/24W	LB65/Titan		70	65	60													
	Mid	LB6500	3/24W	LB65/Titan			60	55	50	47	120Hz	T240	3D	webOS	Magic						
		LB6300	3/24W	LB65/Silver			5/19W	65	60	55	50					47	42				
LED	Low	LB6190	5/19W	LB65/Titan			65	4/14W		60	55	50	47	60Hz	L14	Case Top	3D	L-con			
		LB6100	2/24W	LB56/Silver						60	55	50	47	120Hz	M13	Top Open		NC 4.5	S-con		
		LB6000	2/24W	LB56/Titan						60	55	50	47	60Hz (T120)	L14				L-con		
		LB5800/B	2/24W	LB56/Silver						60	55	50	47	60Hz	M13			NC 4.5	S-con		
		LB5600	Drop-in	LB56/Titan						60	55	50	47	60Hz	L14					L-con	
		LB5500/B	Drop-in	LB55/Black						55	49	42	32H	120Hz	L14					L-con	
		LN5400	Garry-over							60	55	50	47	42	60Hz	L13	사출			L-con	
		LN5300/B	Garry-over												60Hz	L14	Casetop				L-con
		LB4700	4/14W												60Hz	L14	사출				L-con
		LB4500	2/17W												60Hz	L14	사출				L-con
PDP	Mid	PB6900	2/17W						60					M13		3D	NC 4.5	L-con			
		PB6600	3/03W						60	50											
	Low	PB5600/B	3/03W						60		50H				L14				L-con		
		PN4500	Garry-over												L13					L-con	

- LB6500 (전학도장)
- LB5800 (Color PCM)
- LB5600 (Color PCM)
- LB5500 (일반 PCM)

◆ CONTENT ◆

1. '2014 Product line-up and features

2. Model naming and tool option

3. New features

4. Main PCBs

5. Block Diagrams, IIC Map

6. Structure of TV set and connection of sub assy's

7. New sub assy's

- Instruction of new sub assy's



- How to use tool

- Download

8. Repair guide

Model naming and Tool option



Standard of 2014 Model Name	 Model Name
Description of Tool Options	 Tool option info

◆ CONTENT ◆

1. '2014 Product line-up and features
2. Model naming and tool option
- 3. New features**
4. Main PCBs
5. Block Diagrams, IIC Map
6. Structure of TV set and connection of sub assy's
7. New sub assy's
 - Instruction of new sub assy's
 - How to use tool
 - Download
8. Repair guide

webOS Architecture

- Luna Bus에 기반하여 서비스 및 응용을 통합함으로써, 개발 독립성과 기능 확장성을 제고한다.
- Web 응용 프레임워크에 기반하여 응용 개발 생산성을 높인다.
- webOS 프로세스 및 자원 관리를 통해 시스템 자원을 효율적 활용할 수 있도록 한다 (멀티 Tasking)

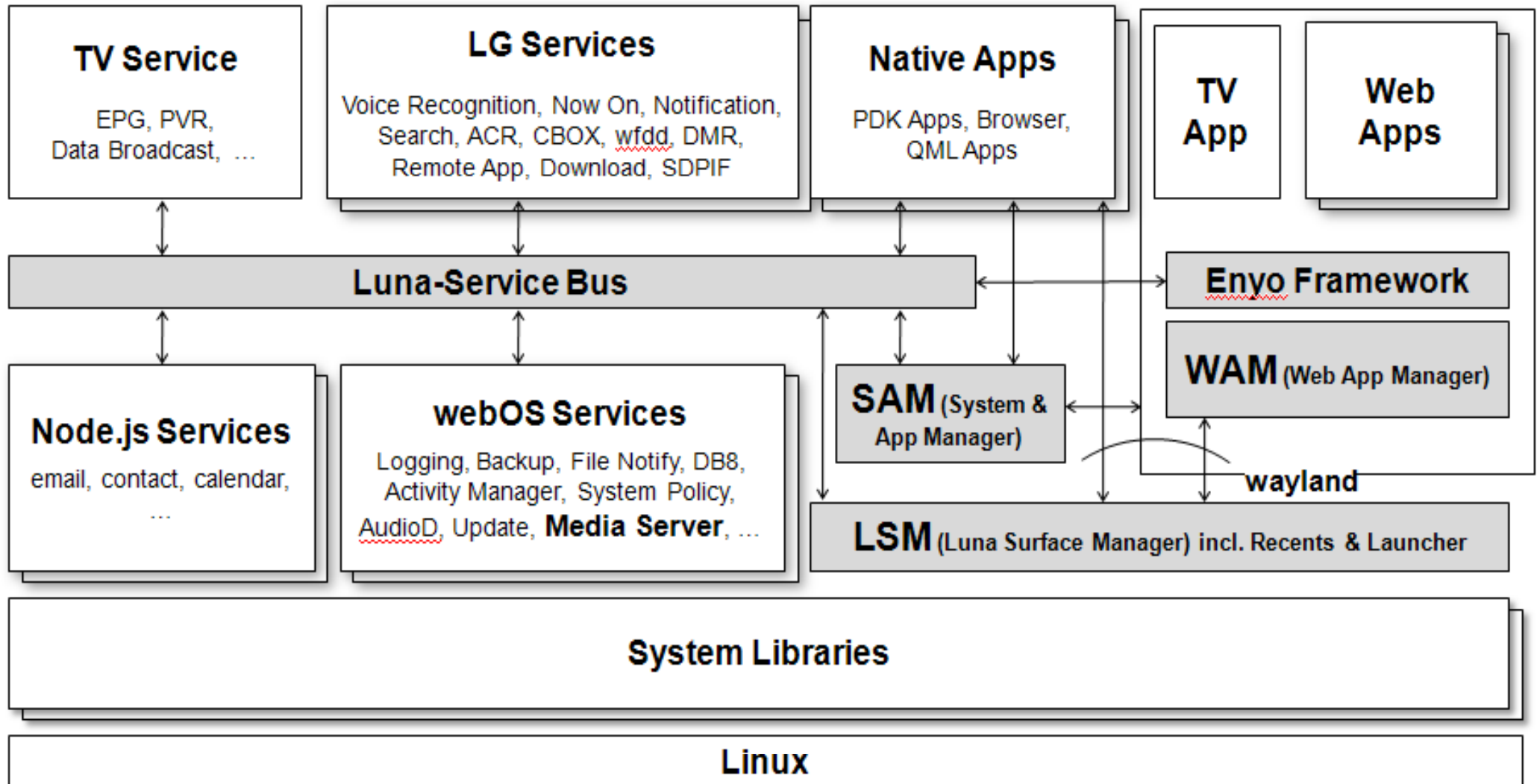

◆ CONTENT ◆

1. '2014 Product line-up and features
2. Model naming and tool option
3. New features
- 4. Main PCBs**
5. Block Diagrams, IIC Map
6. Structure of TV set and connection of sub assy's
7. New sub assy's
 - Instruction of new sub assy's
 - How to use tool
 - Download
8. Repair guide

Main PCB for Broadband

xxLB7200-UB

Chassis : LA42B
PCB P/No : EAX65363904

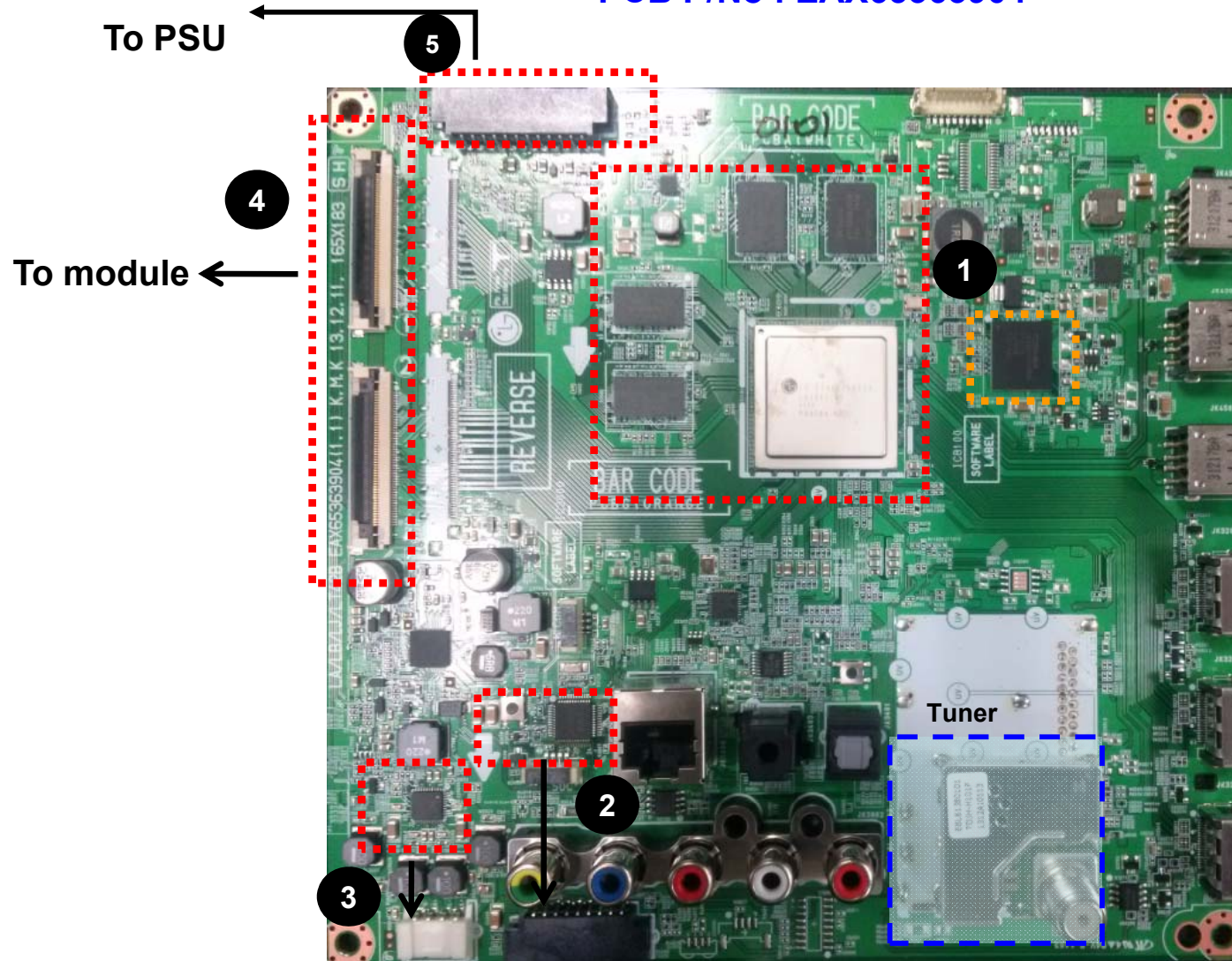

Front Spk
1. Key + IR
2. WIFI + BT

- 1 Main processor, DDR Memory
eMMC Memory
- 2 Micom for Key/IR sensing
WiFi + BT(Magic Remocon receiver)
- 3 Audio AMP (12W+12W)
- 4 LVDS or EPI Wafer
- 5 PSU

Main PCB for Broadband

xxLB7100-xx

Chassis : LA42B
PCB P/No : EAX65363904

To PSU ← 5

To module ← 4

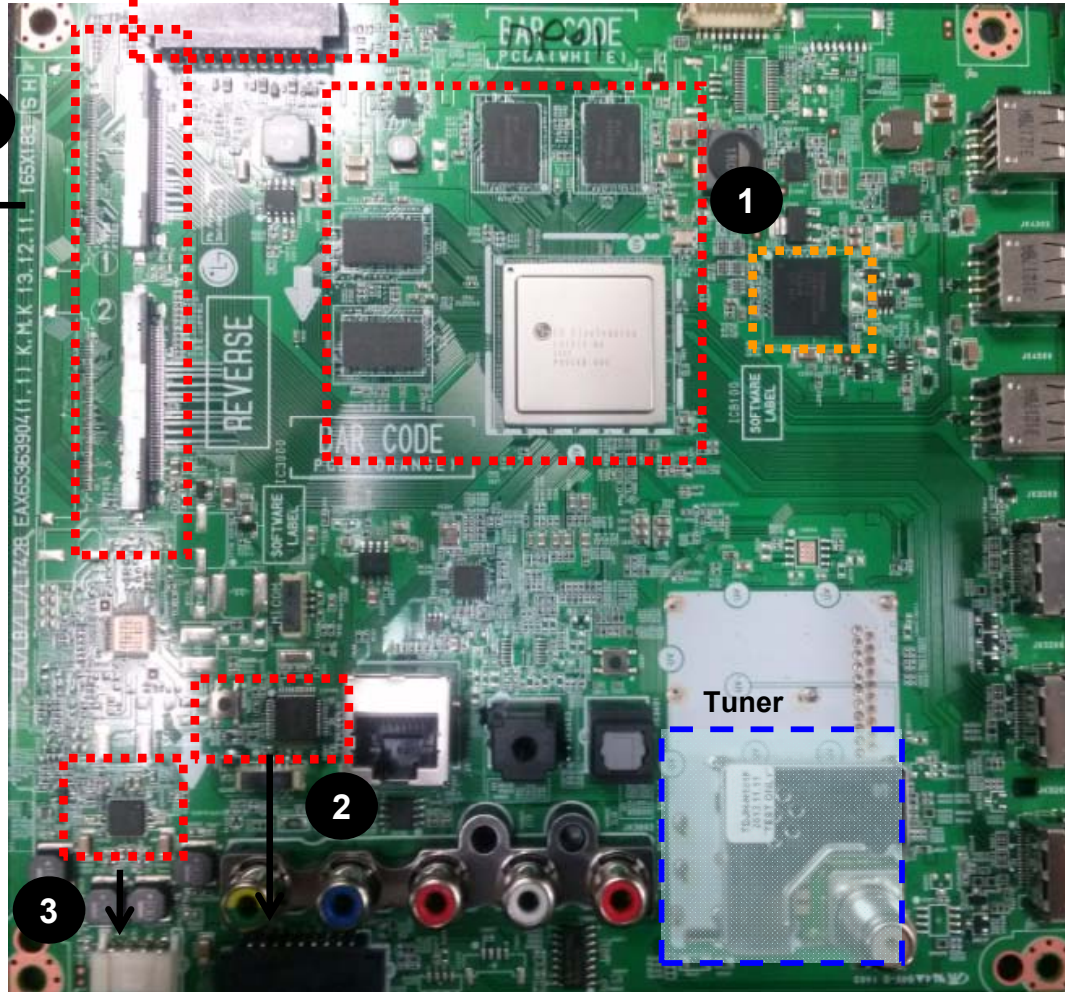

- 1 Main processor, DDR Memory
eMMC Memory
- 2 Micom for Key/IR sensing
WiFi + BT(Magic Remocon receiver)
- 3 Audio AMP (12W+12W)
- 4 LVDS or EPI Wafer
- 5 PSU

Front Spk 3
1. Key + IR
2. WIFI + BT

Main PCB for Broadband

xxLB65/6300-xx

Chassis : LA42B
PCB P/No : EAX65363904

To PSU ← 5

4
To module ←

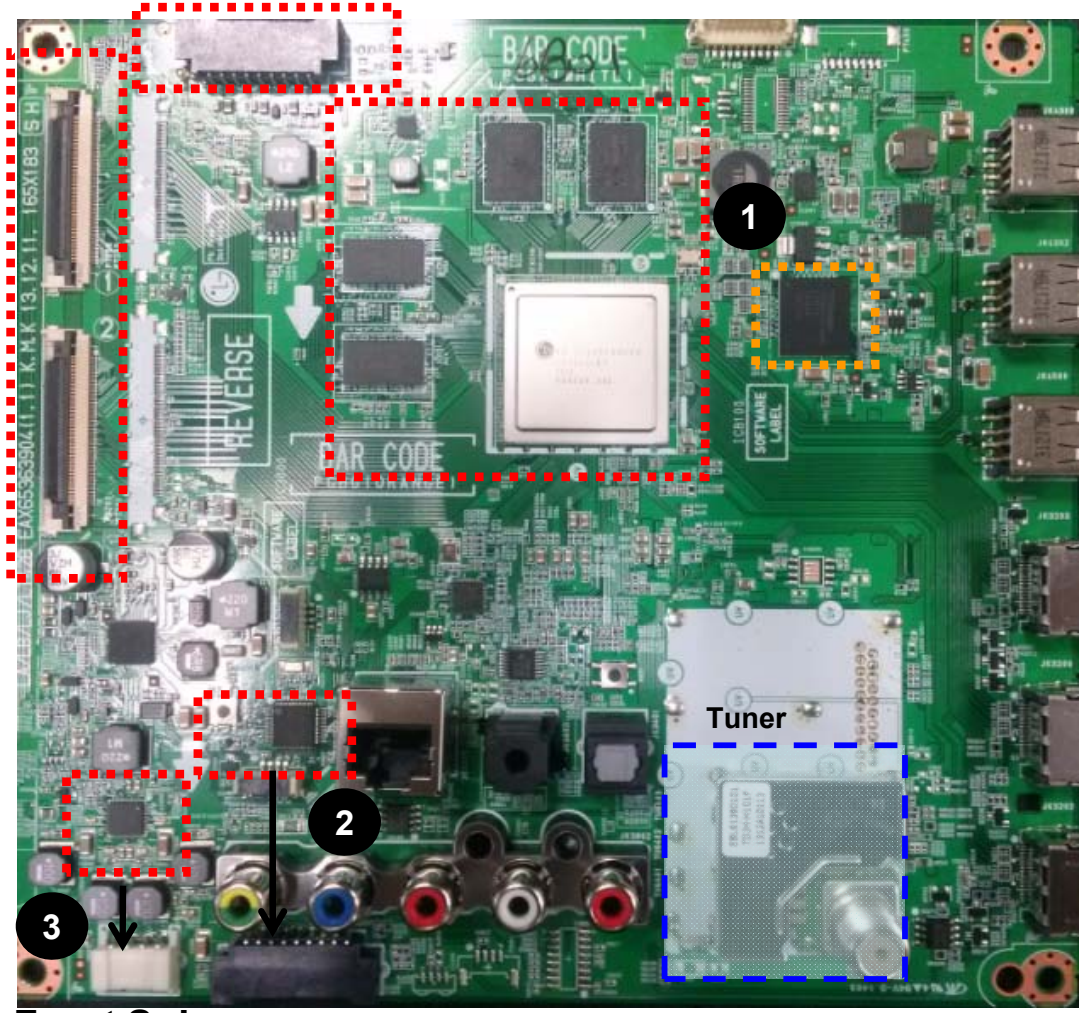

- 1 Main processor, DDR Memory
eMMC Memory
- 2 Micom for Key/IR sensing
WiFi + BT(Magic Remocon receiver)
- 3 Audio AMP (12W+12W)
- 4 LVDS or EPI Wafer
- 5 PSU

Front Spk
1. Key + IR
2. WIFI + BT

◆ CONTENT ◆

1. '2014 Product line-up and features
2. Model naming and tool option
3. New features
4. Main PCBs
- 5. Block Diagrams, IIC Map**
6. Structure of TV set and connection of sub assy's
7. New sub assy's
 - Instruction of new sub assy's
 - How to use tool
 - Download
8. Repair guide

2. M14 I2C Block Diagram

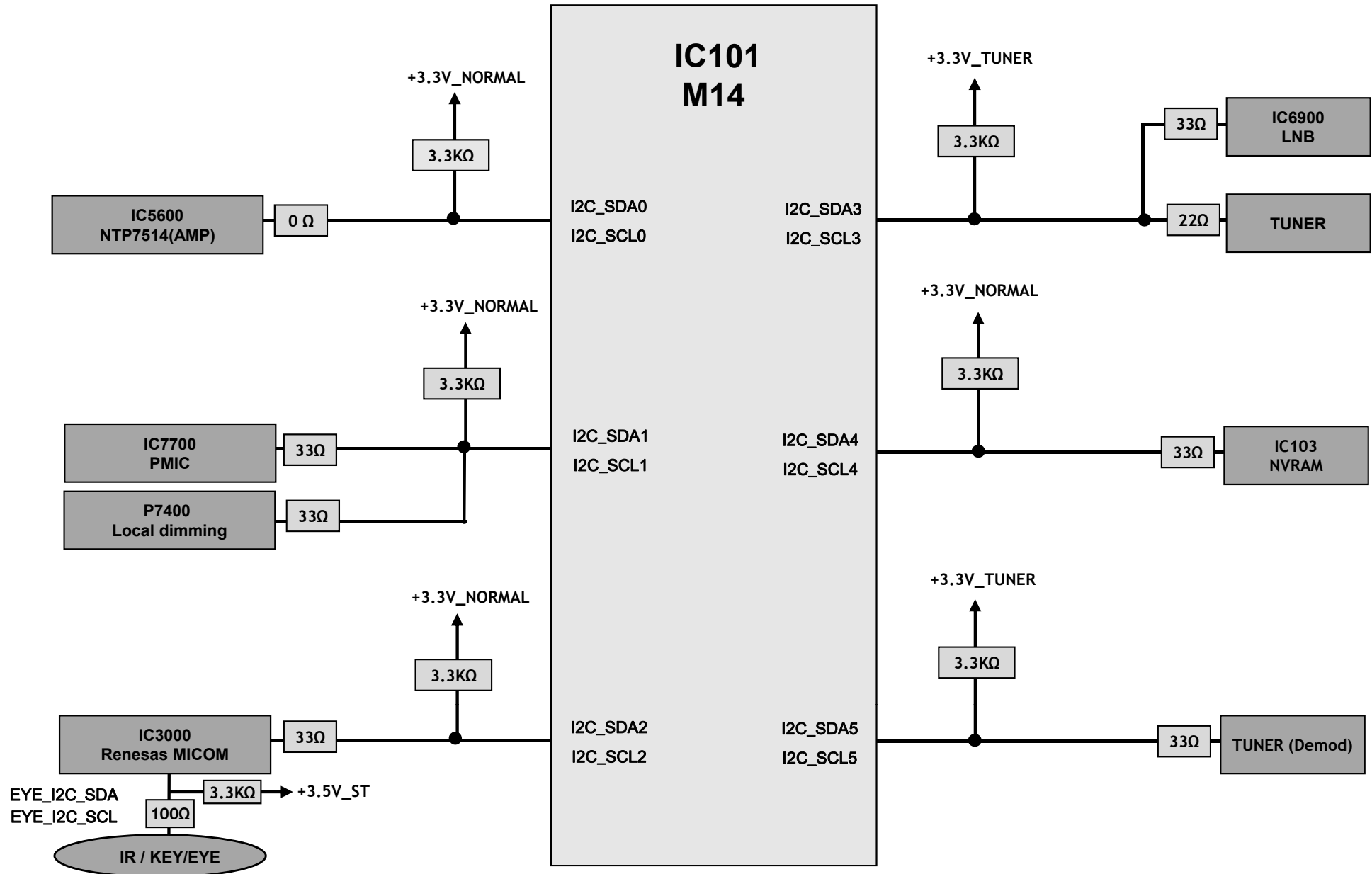

3. Power Block Diagram

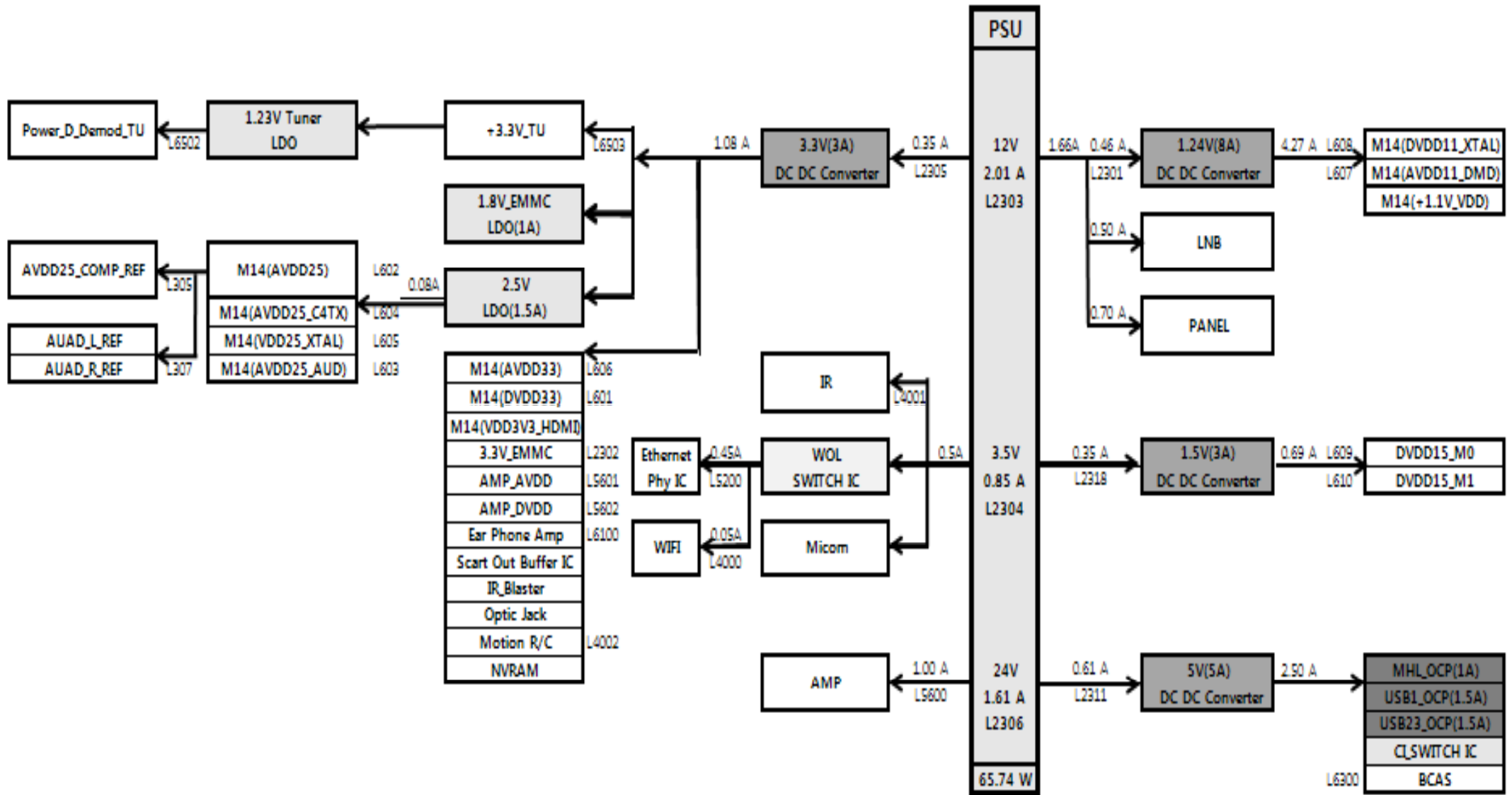

4. Tuner Block Diagram (US 1 Tuner)

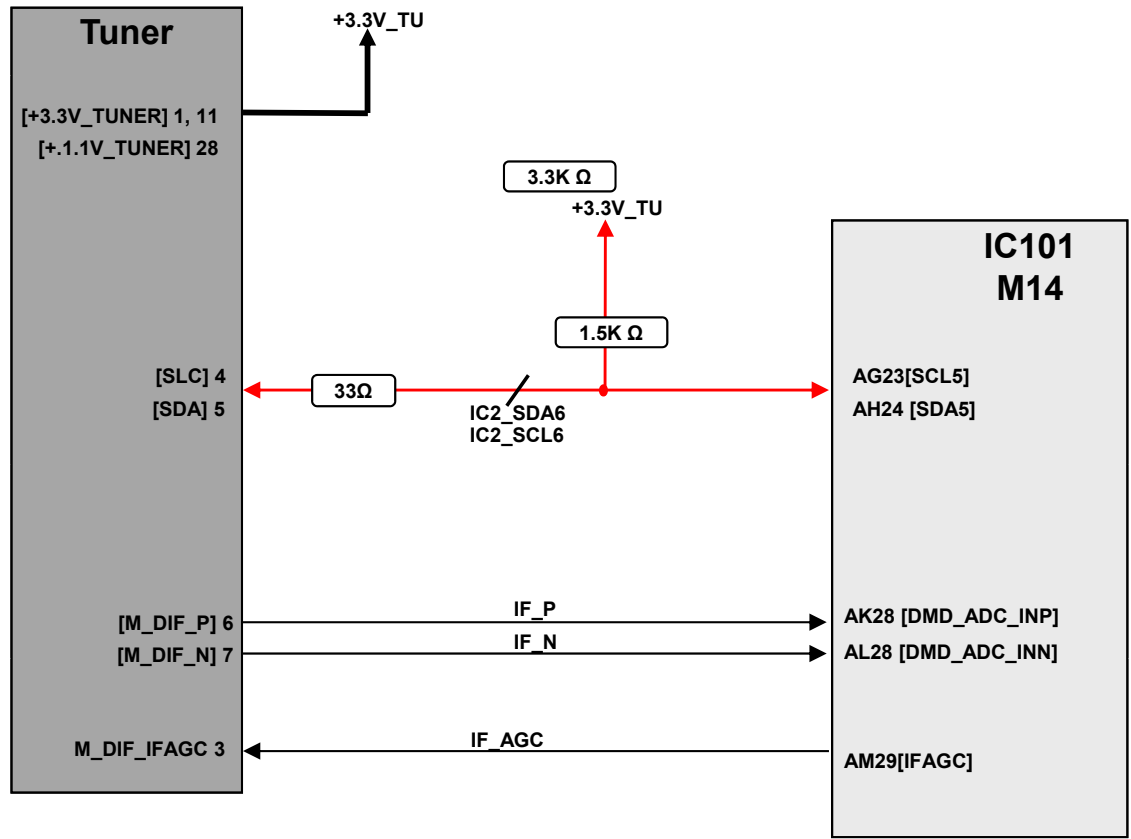

5. Video/Audio In Block Diagram

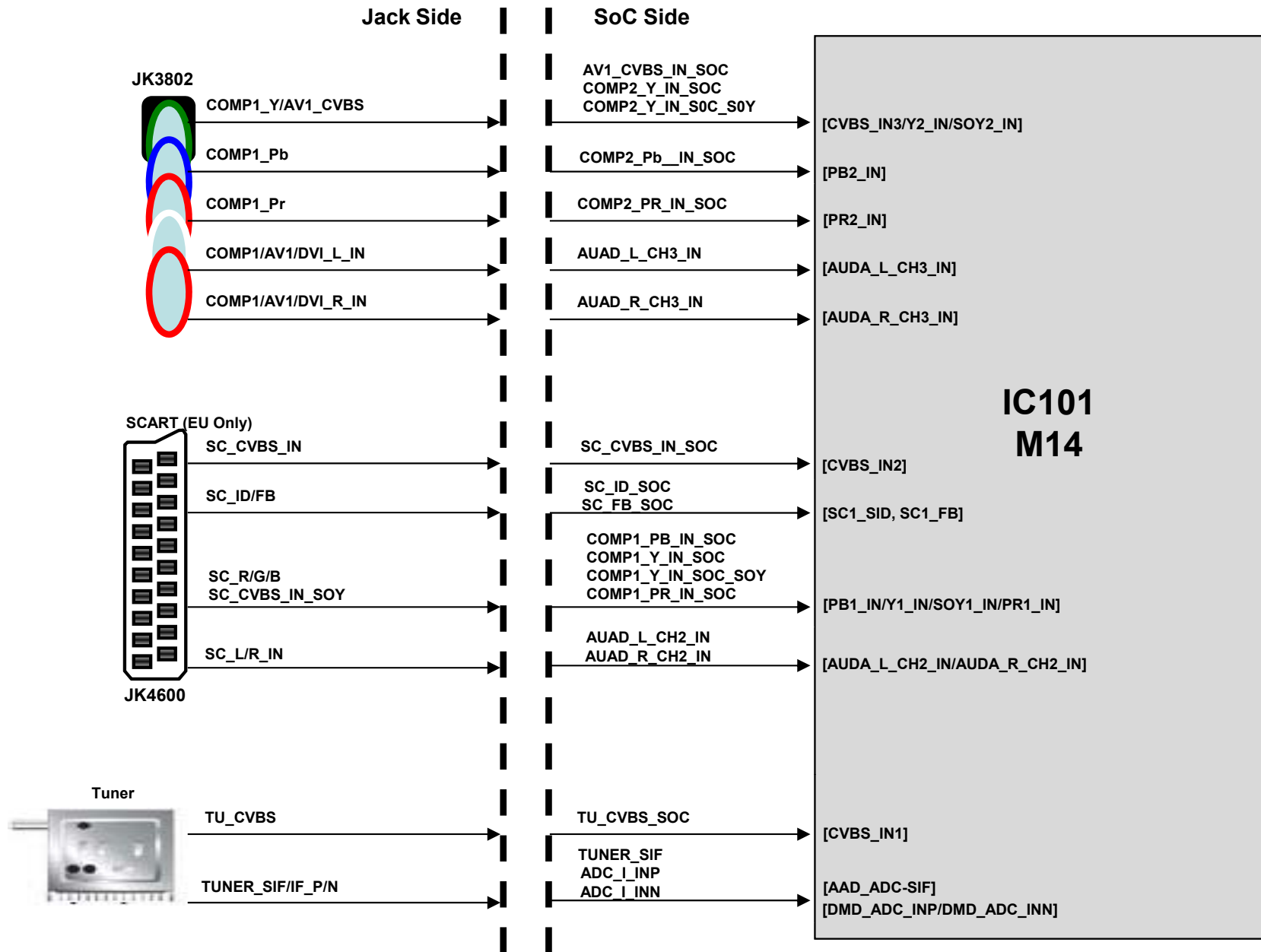

6. Audio Out Block Diagram

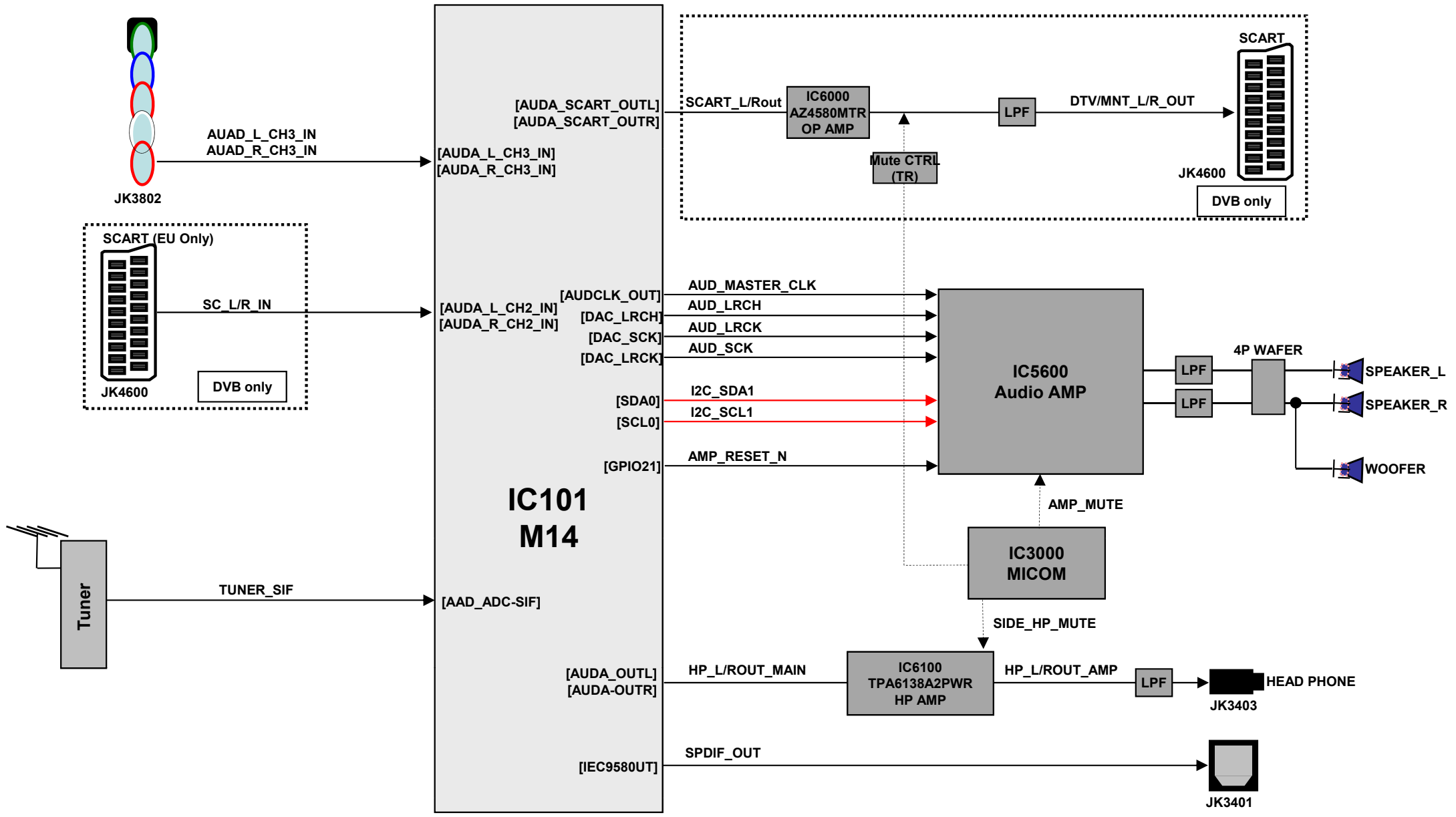

7. HDMI

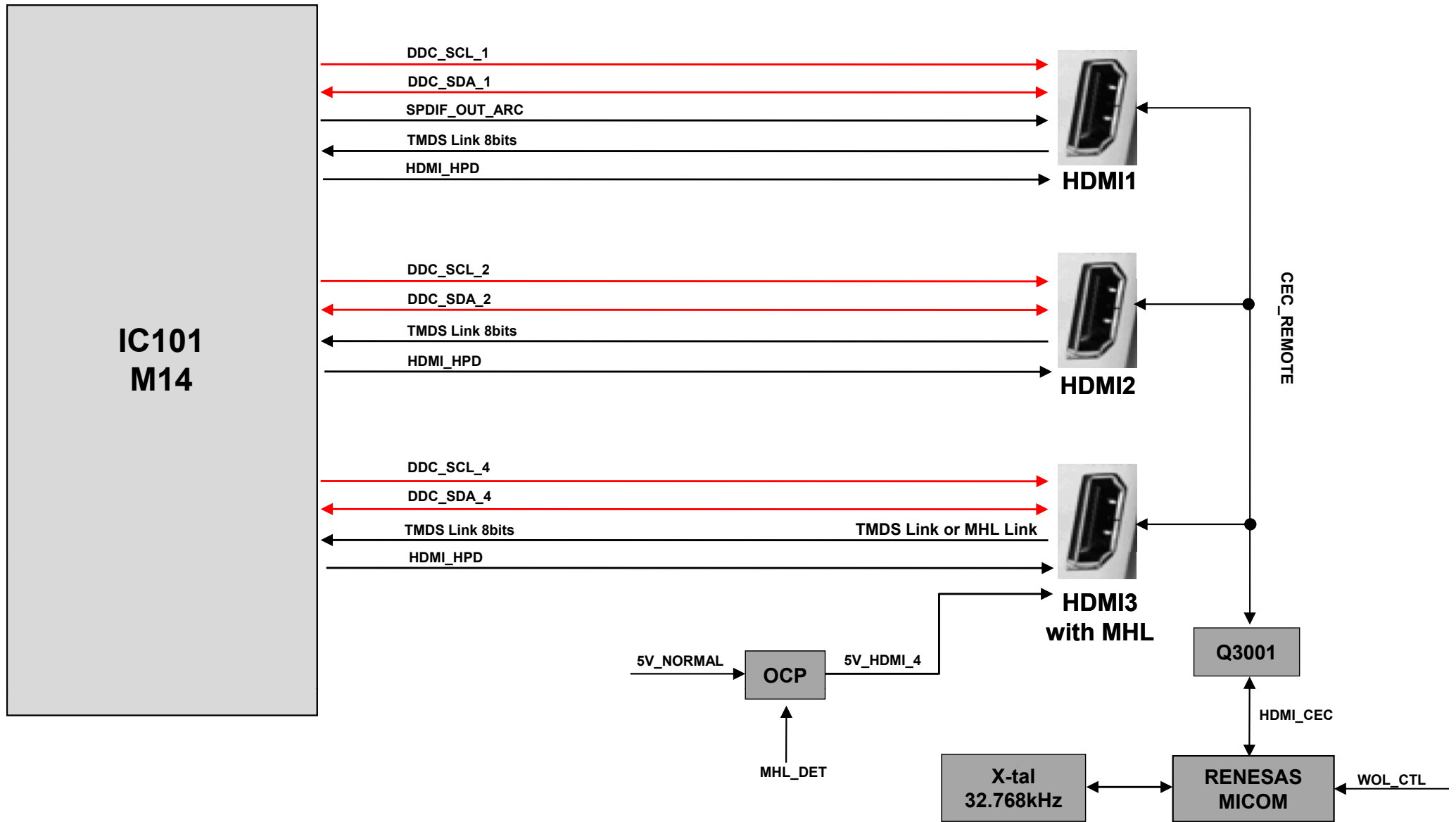

8. Panel Interface Block Diagram

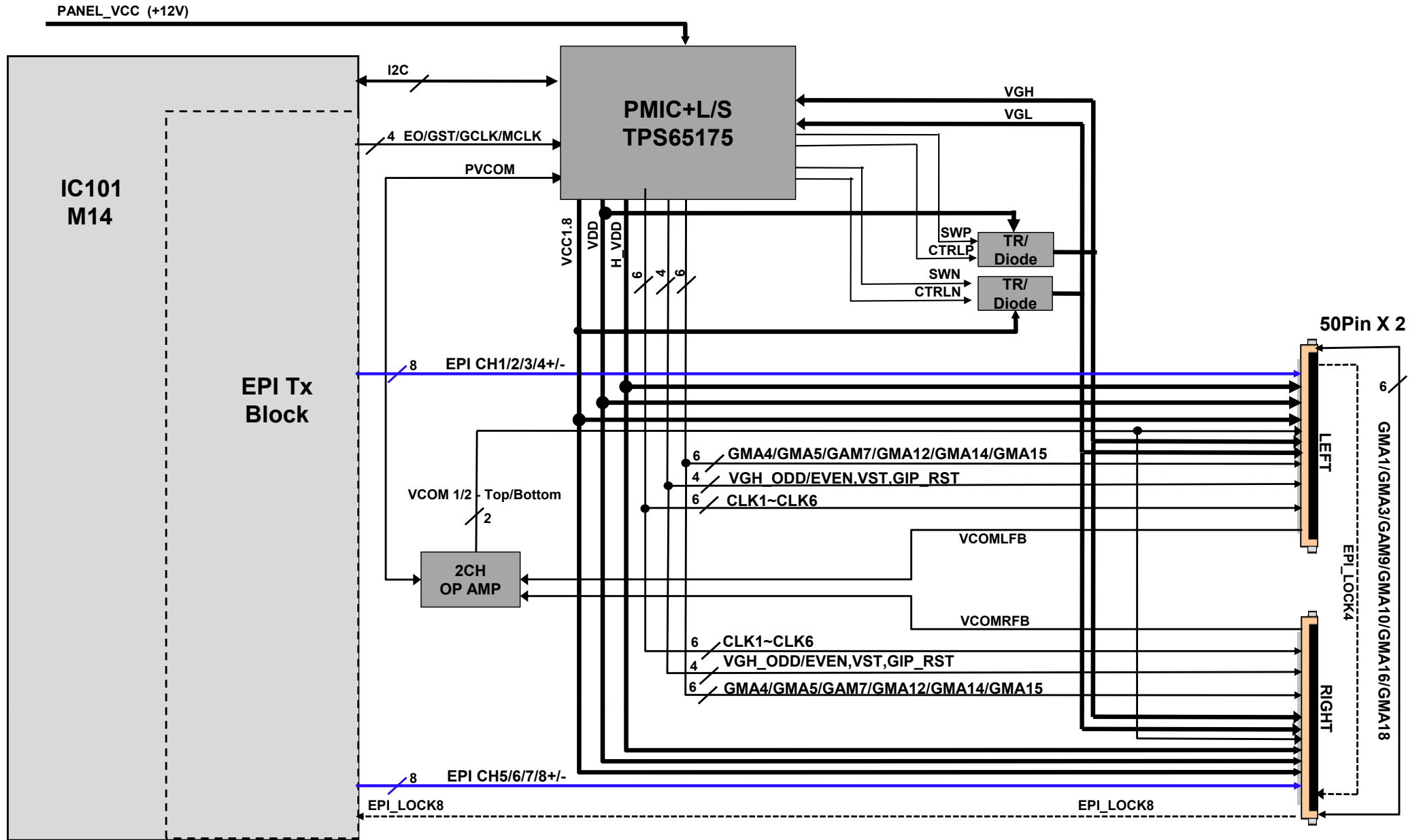

9. USB 2.0 / WIFI-BT / IR-KEY-EYE

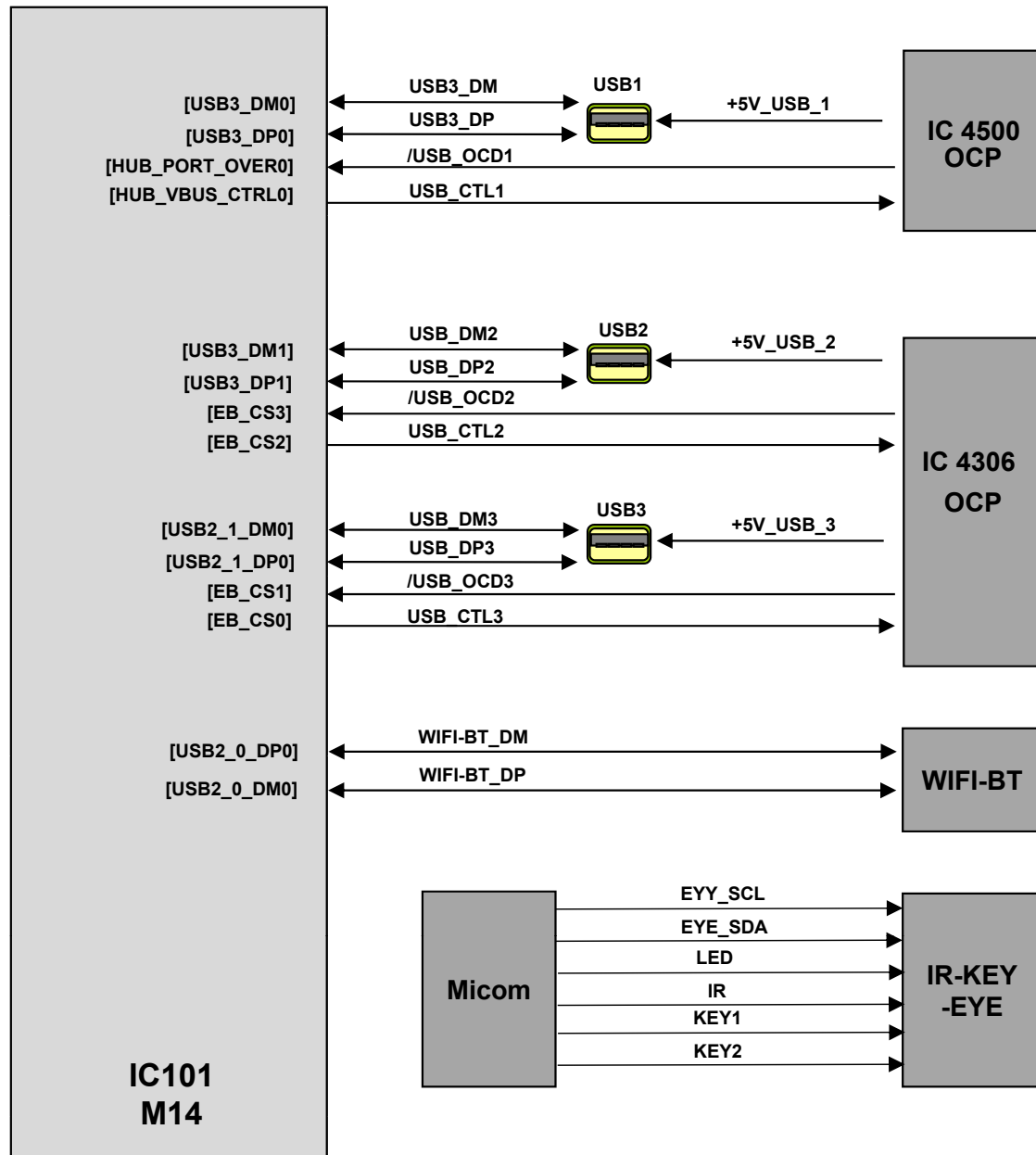

◆ CONTENT ◆

1. '2014 Product line-up and features
2. Model naming and tool option
3. New features
4. Main PCBs
5. Block Diagrams, IIC Map
- 6. Structure of TV set and connection of sub assy's**
7. New sub assy's
 - Instruction of new sub assy's
 - How to use tool
 - Download
8. Repair guide

Interconnection

55LB7200-UB

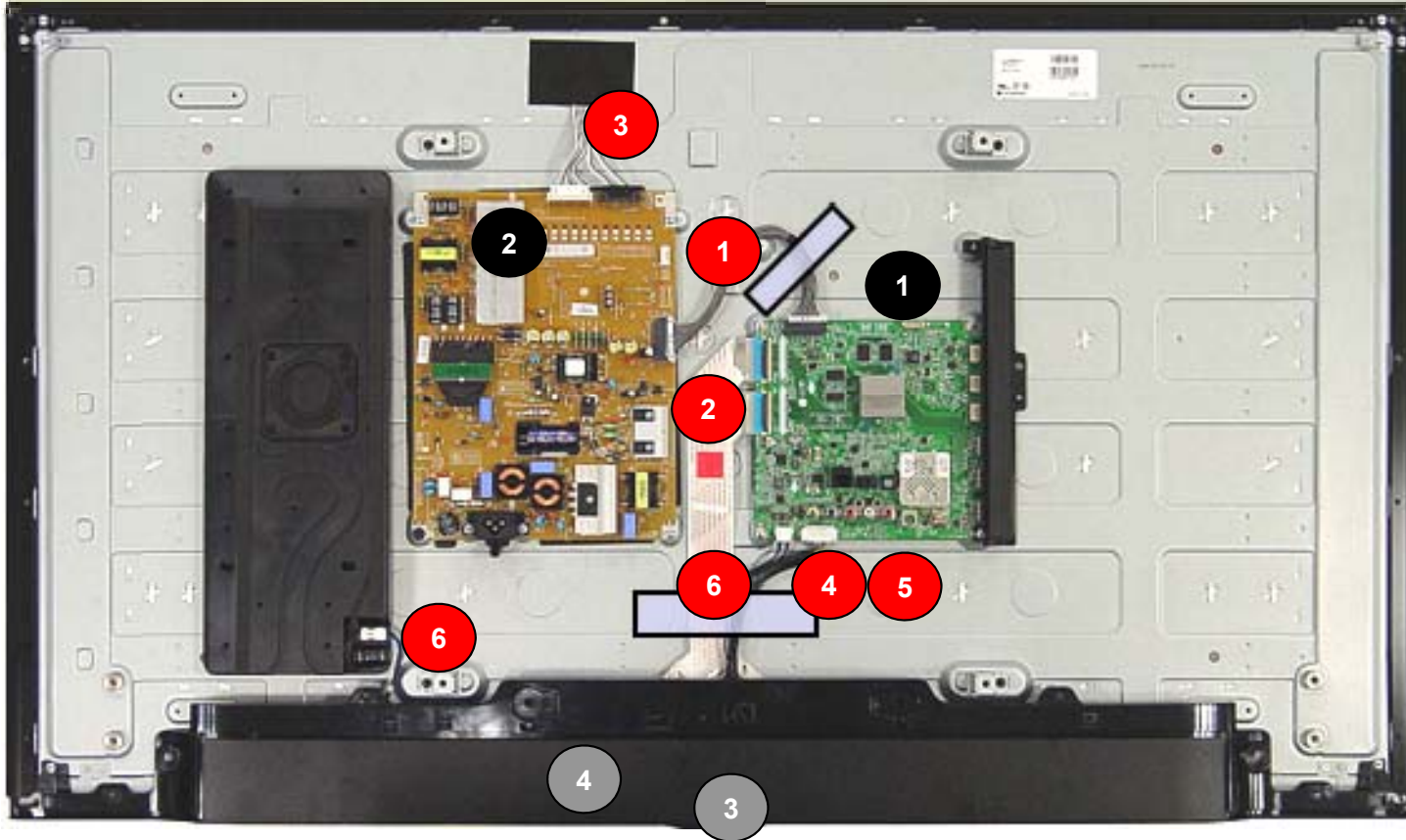

[PCBs]

- 1 Main PCB
- 2 Power Board
- 3 IR / Key Assy
- 4 WIFI/BT Assy

[Cables]

- 1 Main / LPB 24Pin cable
- 2 Main / Module LVDS Cable
- 3 LED driver / PSU
- 4 10Pin IR+key Cable
- 5 8Pin WIFI/BT Assy Cable
- 6 SPK Cable

Interconnection

70LB7100-UC

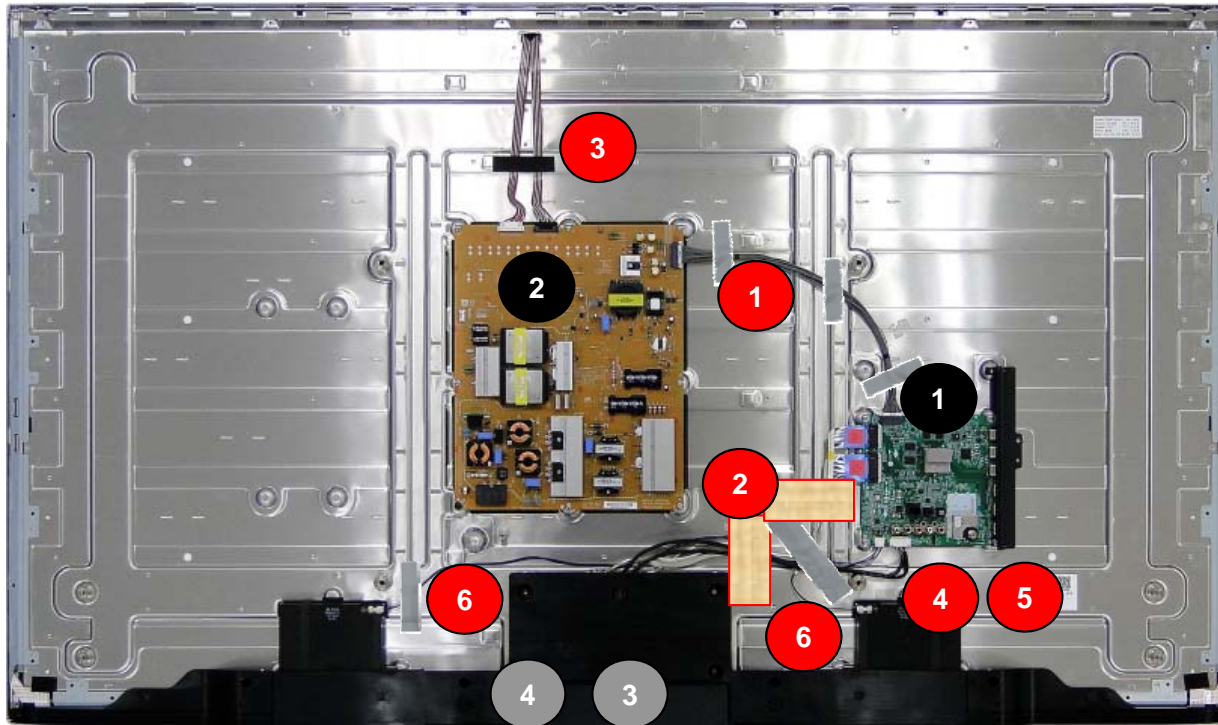

[PCBs]

- 1 Main PCB
- 2 Power Board
- 3 IR / Key Assy
- 4 WIFI/BT Assy

[Cables]

- 1 Main / LPB 24Pin cable
- 2 Main / Module LVDS Cable
- 3 LED driver / PSU
- 4 10Pin IR+key Cable
- 5 8Pin WIFI/BT Assy Cable
- 6 SPK Cable

Interconnection

60LB7100-UT

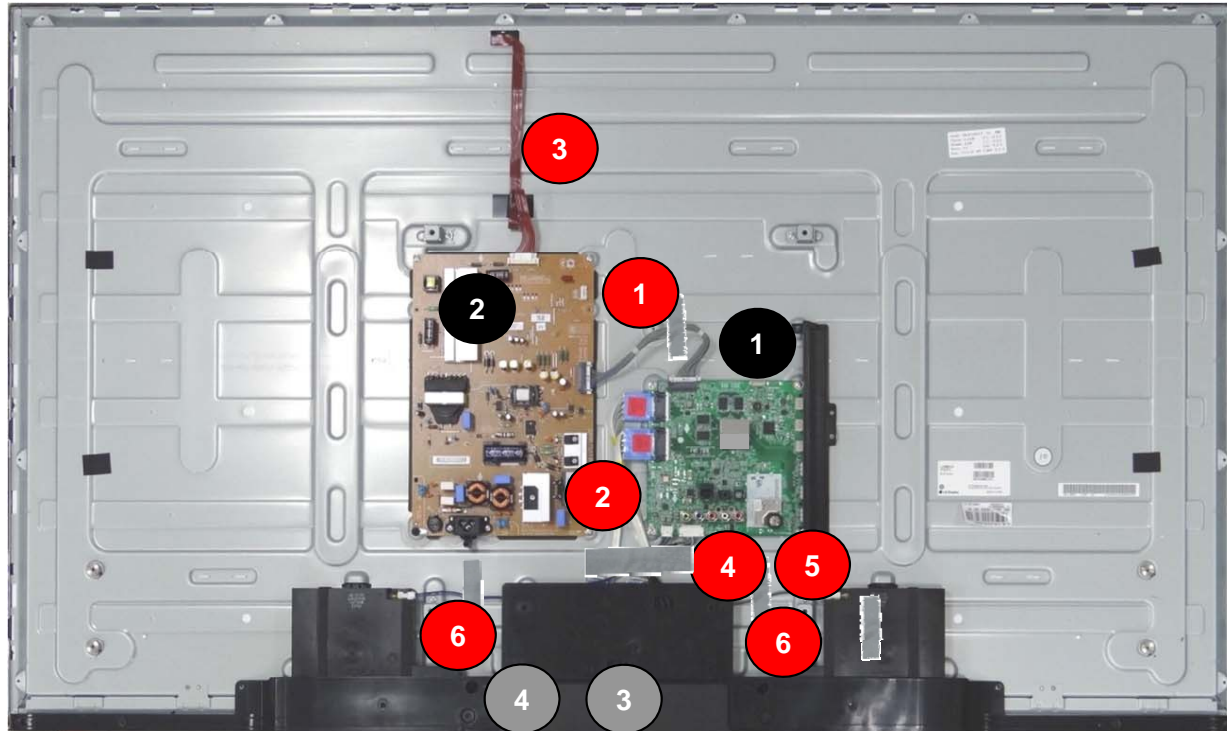

[PCBs]

- 1 Main PCB
- 2 Power Board
- 3 IR / Key Assy
- 4 WIFI/BT Assy

[Cables]

- 1 Main / LPB 24Pin cable
- 2 Main / Module LVDS Cable
- 3 LED driver / PSU
- 4 10Pin IR+key Cable
- 5 8Pin WIFI/BT Assy Cable
- 6 SPK Cable

Interconnection

55LB6500-UM

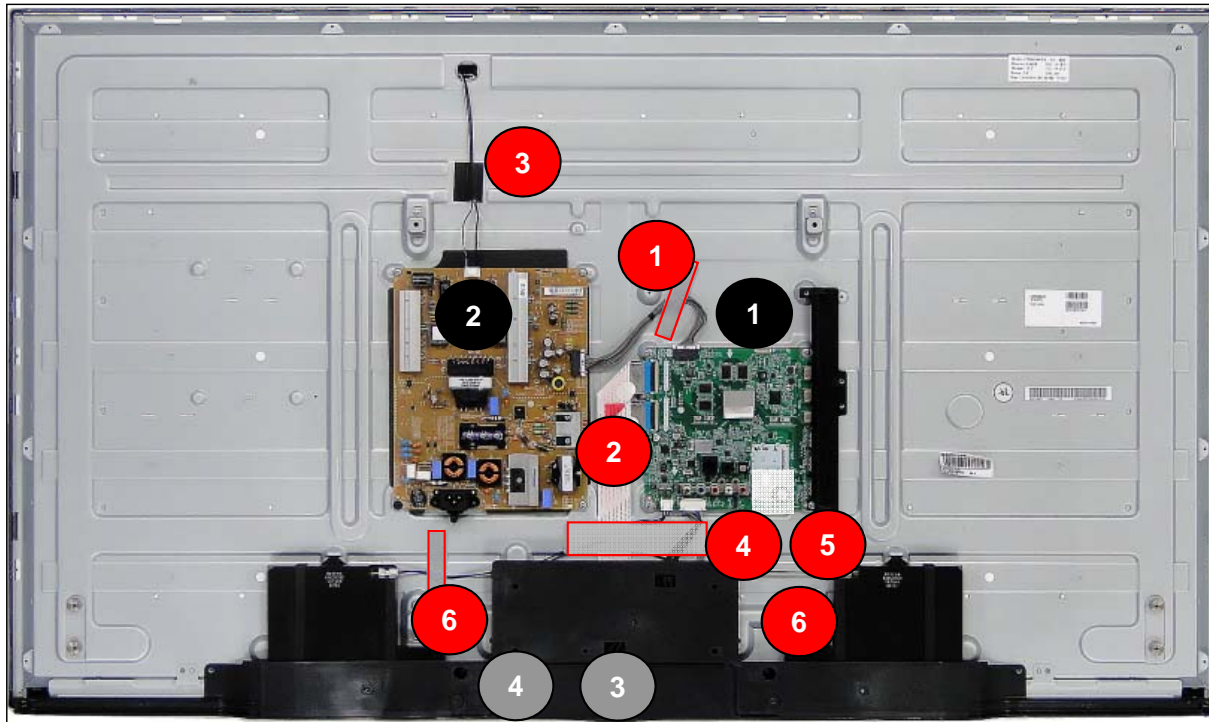

[PCBs]

- 1 Main PCB
- 2 Power Board
- 3 IR / Key Assy
- 4 WIFI/BT Assy

[Cables]

- 1 Main / LPB 24Pin cable
- 2 Main / Module LVDS Cable
- 3 LED driver / PSU
- 4 10Pin IR+key Cable
- 5 8Pin WIFI/BT Assy Cable
- 6 SPK Cable

Interconnection

42LB6500-UM(AUO)

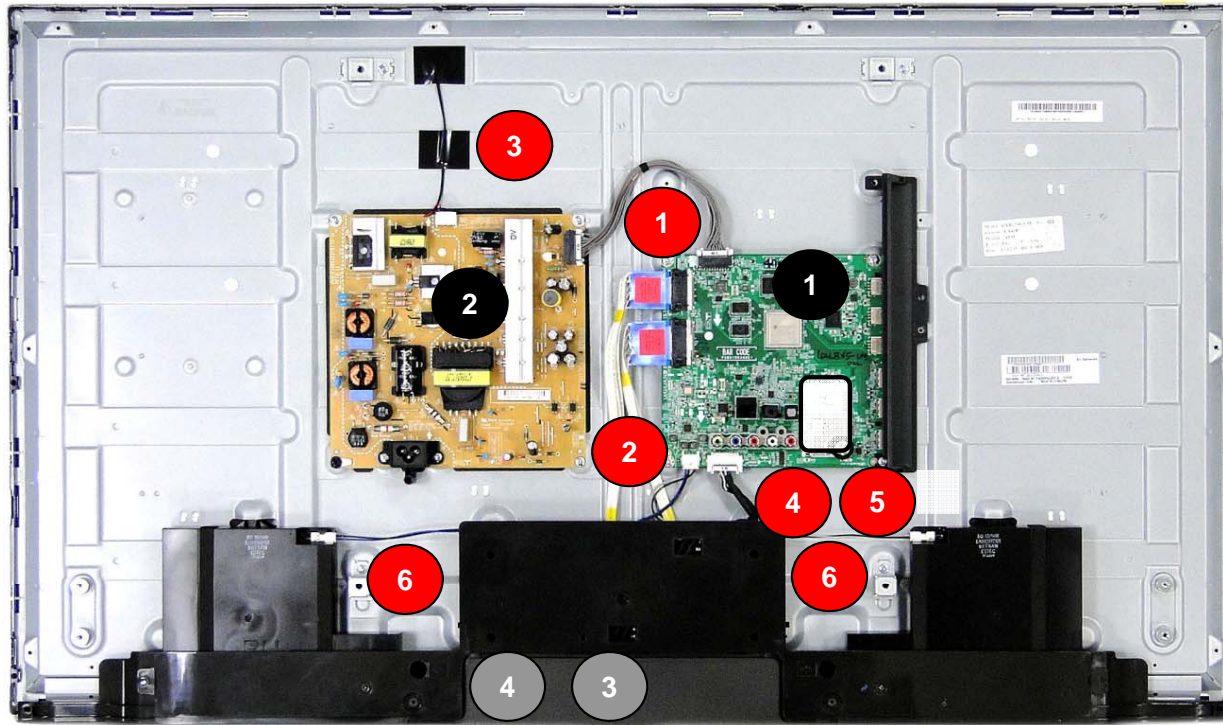

[PCBs]

- 1 Main PCB
- 2 Power Board
- 3 IR / Key Assy
- 4 WIFI/BT Assy

[Cables]

- 1 Main / LPB 24Pin cable
- 2 Main / Module LVDS Cable
- 3 LED driver / PSU
- 4 10Pin IR+key Cable
- 5 8Pin WIFI/BT Assy Cable
- 6 SPK Cable

◆ CONTENT ◆

1. '2014 Product line-up and features
2. Model naming and tool option
3. New features
4. Main PCBs
5. Block Diagrams, IIC Map
6. Structure of TV set and connection of sub ass'ys
- 7. New sub assy's**
 - Instruction of new sub assy's
 - How to use tool
 - Download
8. Repair guide

Introductions of 14Y WIFI / BT built in assy + Magic Remote control

Table of Contents

- 1. System**
- 2. Block diagram**
- 3. Paring method**

1. System

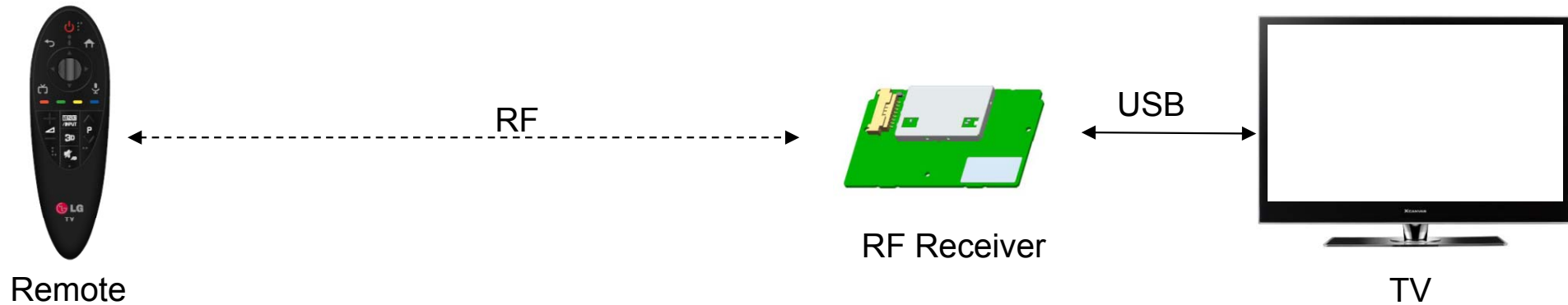

❖ *Pairing Information Transmission (Send to TV after Paired)*

- Static Calibration Data (Bypass only)
- Remote FW ver. (Save also in Receiver)
- BD_ADDR (Save also in Receiver)
- *Pairing Information Transmission Sequence*
 - When it is paired, the remote sends packets(pairing success, F/W version, BD_ADDR) to the receiver.
 - The receiver sends the pairing success packet to TV directly.
 - F/W version and BD_ADDR packets are just saved on the receiver.
 - The receiver sends F/W version or BD_ADDR packet to TV when it is required.

❖ *Motion Data Transmission*

- Period : 7.5msec
- Motion Data : gyro, accelerometer

❖ *Voice Data Transmission*

- Period : 10msec
- Voice sampling : 16khz 16bit

2. MR14 Block Diagram

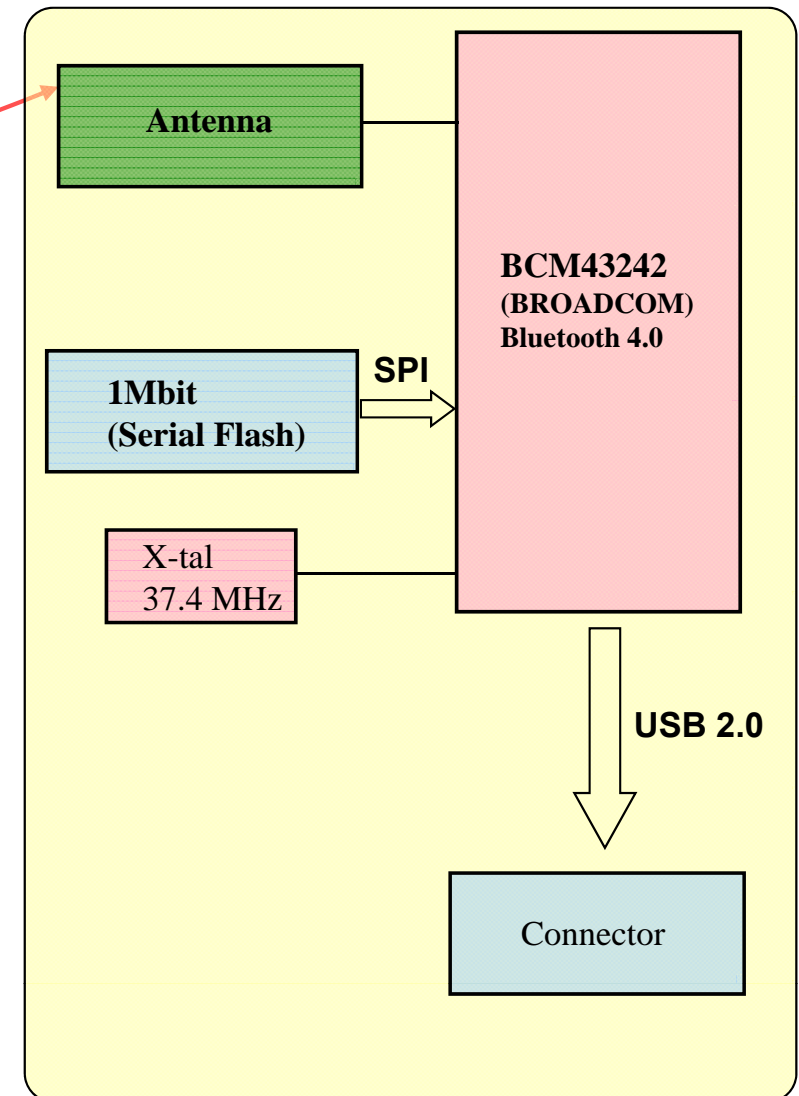
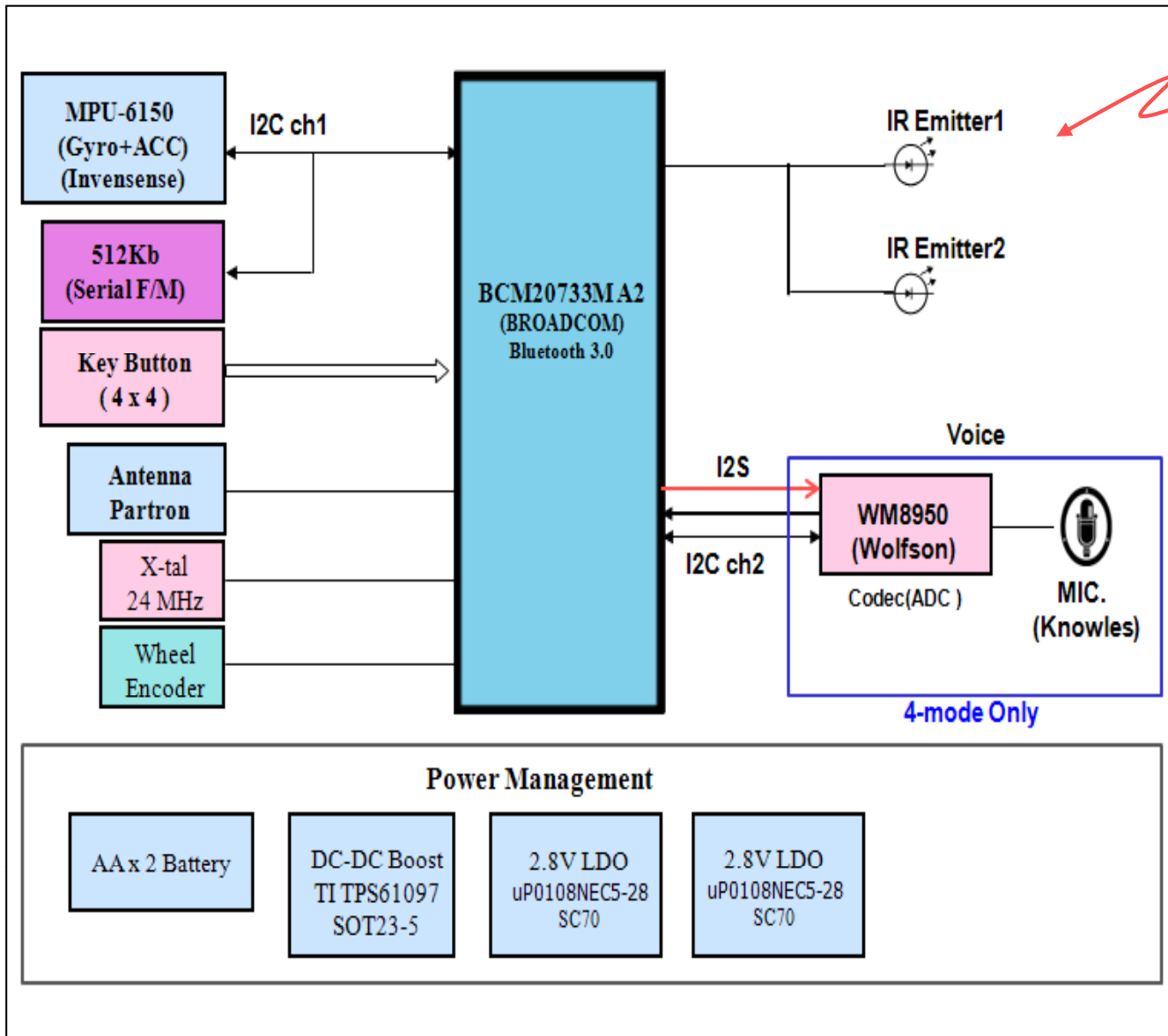

3. RF Pairing / Un-pairing Method

	Method	Description
RF Pairing	<ul style="list-style-type: none"> ❖ Method1 <ul style="list-style-type: none"> – If unpaired, just press Wheel key. – If paired, press Wheel key after unpairing. ❖ Method 2 (Repairing) <ul style="list-style-type: none"> – Press “BACK” button for 5 sec. 	<ul style="list-style-type: none"> • When do pairing, the remote should make pairing request IR signal(0x29) to TV. • When TV receive the IR signal, it should send "pairing request packet" to the RF receiver. • After pairing success, the remote should blink LED for some time and TV send "pairing success packet" back to TV. • When remote try to unpairing, it doesn't care about state of receiver(stand alone).
RF Unpairing	<p>Press “HOME” button and “BACK” button at the same time for 5 sec.</p>	<ul style="list-style-type: none"> • When remote try to unpairing, it doesn't care about state of receiver(stand alone). • After unpairing, all pairing information should be erased. • After unpairing, LED should be blinked for 3sec. • The remote just becomes to IR mode.

WIFI Built in assy feature

Block diagram

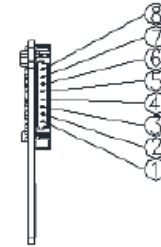

54

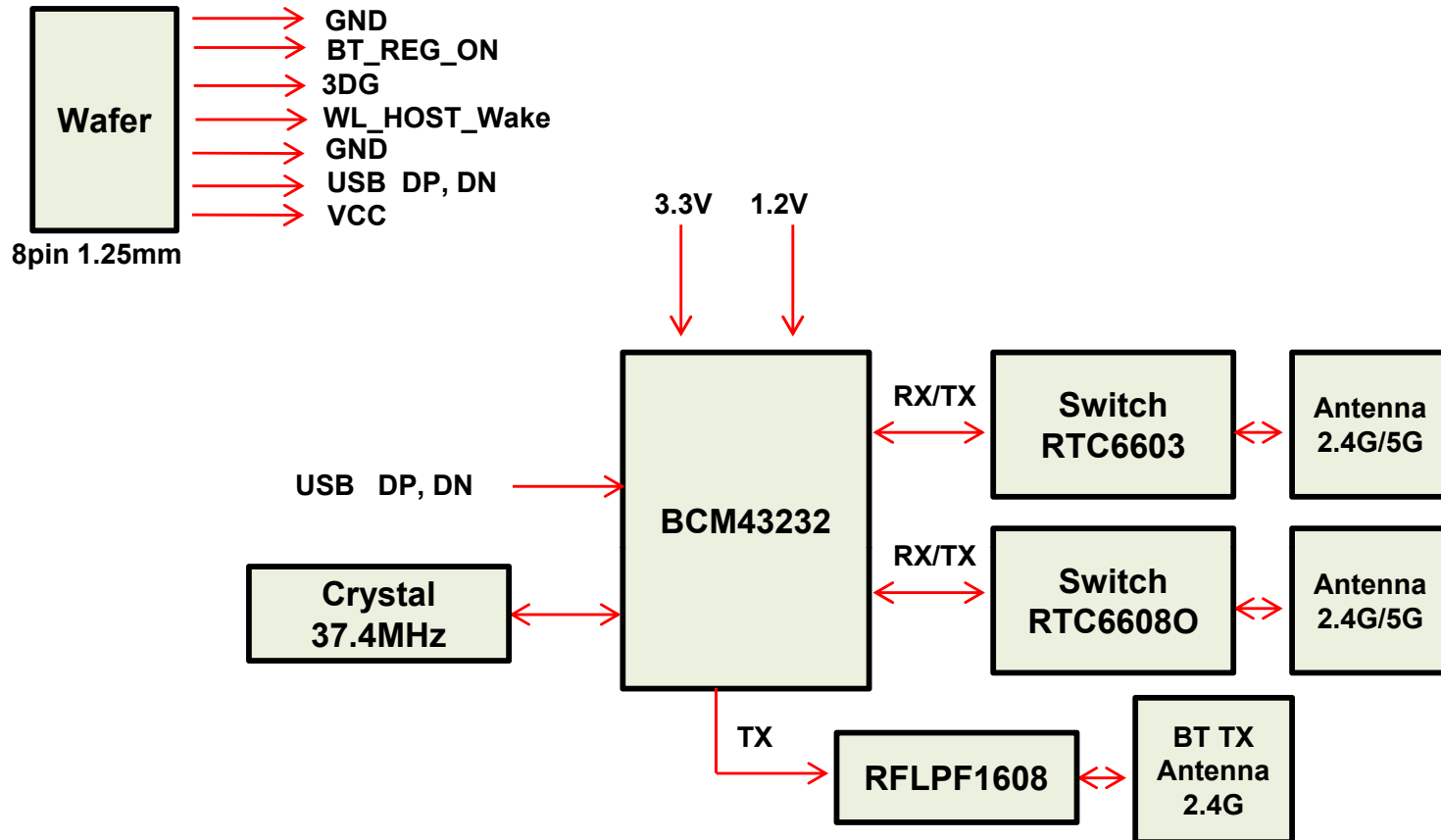

WiFi Built in ass'y Specification

- ◆ Frequency Band:

Draft 802.11n Radio: 2.4 GHz

802.11g Radio: 2.4 GHz

802.11b Radio: 2.4 GHz

USA – FCC

2412~2462MHz (Ch1~Ch11)

Canada – IC

2412~2462MHz (Ch1~Ch11)

Europe – ETSI

2412~2472MHz (Ch1~Ch13)

Japan – STD-T66/STD-33

2412~2484MHz (Ch1~Ch14)

802.11a Radio : 5 GHz

5.150~5.250GHz

5.725~5.850GHz

- ◆ Operating Channels:

IEEE 802.11b/g/n compliant:

11 channels (US, Canada)

13 channels (ETSI)

14 channels (Japan)

- ◆ Transmit Power and Sensitivity:

TX Output Power:(Typical) (Meet emission standard)

11b 17 +/- 2 dBm

11g 14 +/- 2 dBm@54Mbps (Each chain)

11n 13 +/- 2 dBm (Each chain)

Rx Sensitivity:(Typical)

-69dBm at HT20 m7 2.4GHz

-87dBm at HT20 m0 2.4GHz

-69dBm at HT20 m7 5.0GHz

-87dBm at HT20 m0 5.0GHz

- ◆ Modulation

DBPSK @1Mbps

DQPSK@2Mbps

CCK@5.5/11Mbps

BPSK@6/9 Mbps

QPSK@12/18Mbps

16-QAM@24Mbps

64-QAM@48/54Mbps and above

- ◆ Current consumption(5V DC):

Full load: 430mA

- ◆ Operating Temperature: 0 ~ 60 °C ambient

- ◆ Storage Temperature: -20 ~ 60 °C ambient

- ◆ Humidity: under 85% and must be non-condensing

- ◆ Regulation and certification compliance available:

- ◆ CE

- ◆ FCC

- ◆ WiFi



- ◆ WPS



◆ CONTENT ◆

1. '2014 Product line-up and features
2. Model naming and tool option
3. New features
4. Main PCBs
5. Block Diagrams, IIC Map
6. Structure of TV set and connection of sub ass'ys
7. New sub ass'ys
 - Instruction of new sub ass'ys
 - How to use tool
 - Download
- 8. Repair guide**

Contents of LCD TV Standard Repair Process

No.	Error symptom (High category)	Error symptom (Mid category)	Page	Remarks
1	A. Video error	No video/Normal audio	1	
2		No video/No audio	2	
3		Video error, video lag/stop, fail tuning	3, 4	
4		Color error	5	
5		Vertical/Horizontal bar, residual image, light spot, external device color error	6	
6	B. Power error	No power	7	
7		Off when on, off while viewing, power auto on/off	8	
8	C. Audio error	No audio/Normal video	9	
9		Wrecked audio/discontinuation/noise	10	
10	D. Function error	No response in remote controller, key error, recording error, memory error	11	
11		External device recognition error	12	
12	E. Noise	Circuit noise, mechanical noise	13	
13	F. Exterior error	Exterior defect	14	

First of all, Check whether there is SVC Bulletin in GCSC System for these model.

Contents of LCD TV Standard Repair Process Detail Technical Manual

No.	Error symptom	Content	Page	Remarks
1	A. Video error_ No video/Normal audio	Check LCD back light with naked eye	A1	
2		LED driver B+ 24V measuring method		
3		Check White Balance value	A4	
4		Power Board voltage measuring method	A5	
6	A. Video error_ No video/Video lag/stop	TUNER input signal strength checking method	A6	
7		LCD-TV Version checking method	A7	
9	A. Video error_Color error	LCD TV connection diagram	A8	
10		Tuner Checking Part	A9	
11		Check Link Cable (LVDS) reconnection condition		
12		Adjustment Test pattern - ADJ Key	A12	
13		LCD TV connection diagram	A8	
14	A. Video error_Vertical/Horizontal bar, residual image, light spot	Check Link Cable (LVDS) reconnection condition		
15		Adjustment Test pattern - ADJ Key	A12	
16		Exchange T-Con Board (1)	A-1/5	
17	<Appendix> Defected Type caused by T-Con/ Inverter/ Module	Exchange T-Con Board (2)	A-2/5	
18		Exchange LED driver Board (PSU)	A-3/5	
19		Exchange Module itself (1)	A-4/5	
20		Exchange Module itself (2)	A-5/5	

Continue to the next page

LCD TV	Error symptom	A. Video error	Established date	2013. 11 .30	
		No video/ Normal audio	Revised date		1/13

**First of all, Check whether all of cables between board is inserted properly or not.
(Main B/D↔ Power B/D, LVDS Cable,Speaker Cable,IR B/D Cable,,)**

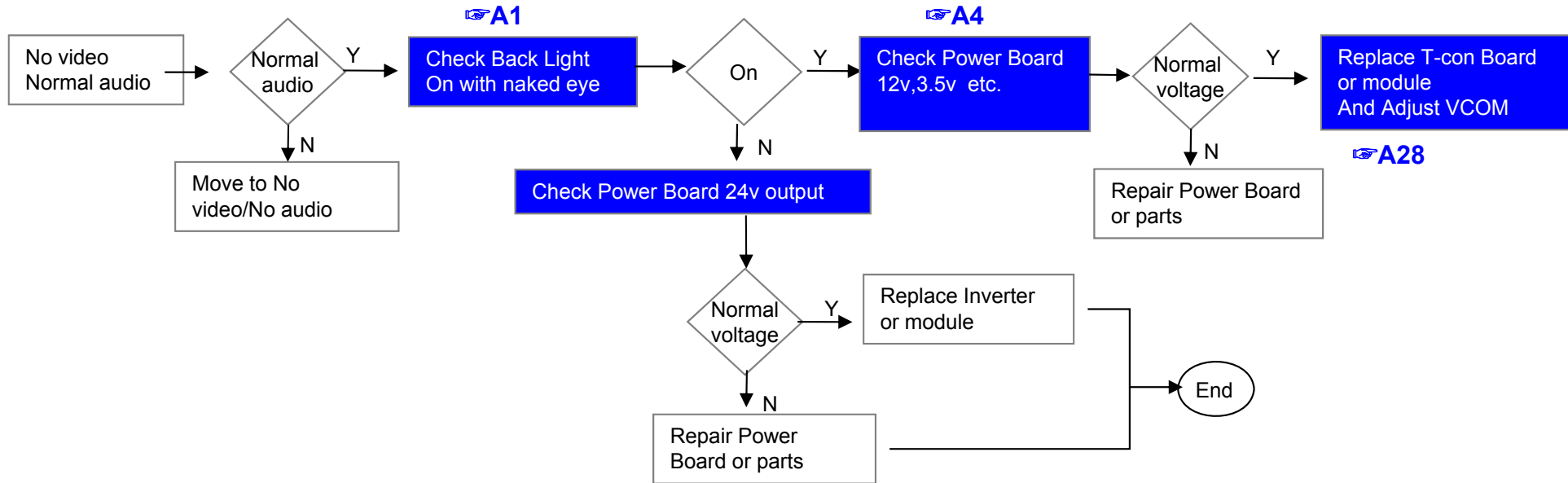

※Precaution **A7**



LCD TV	Error symptom	A. Video error	Established date	2013. 11 .30	
		No video/ No audio	Revised date		2/13

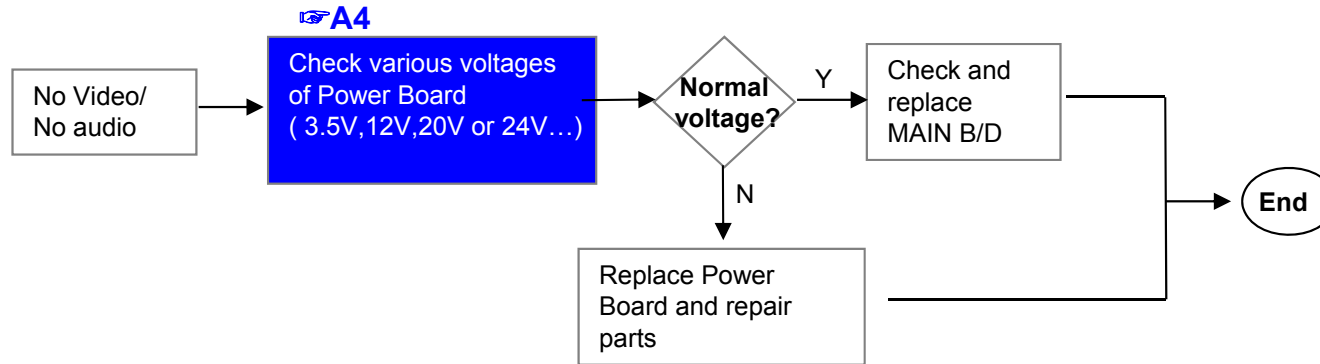

LCD TV	Error symptom	A. Picture Problem	Established date	2013. 11 .30	
		Picture broken/ Freezing	Revised date		3/13

A6

Check RF Signal level

- . By using Digital signal level meter
- . By using Diagnostics menu on OSD
(Menu → Set up → Support → Signal Test)
- Signal strength (Normal : over 50%)
- Signal Quality (Normal: over 50%)

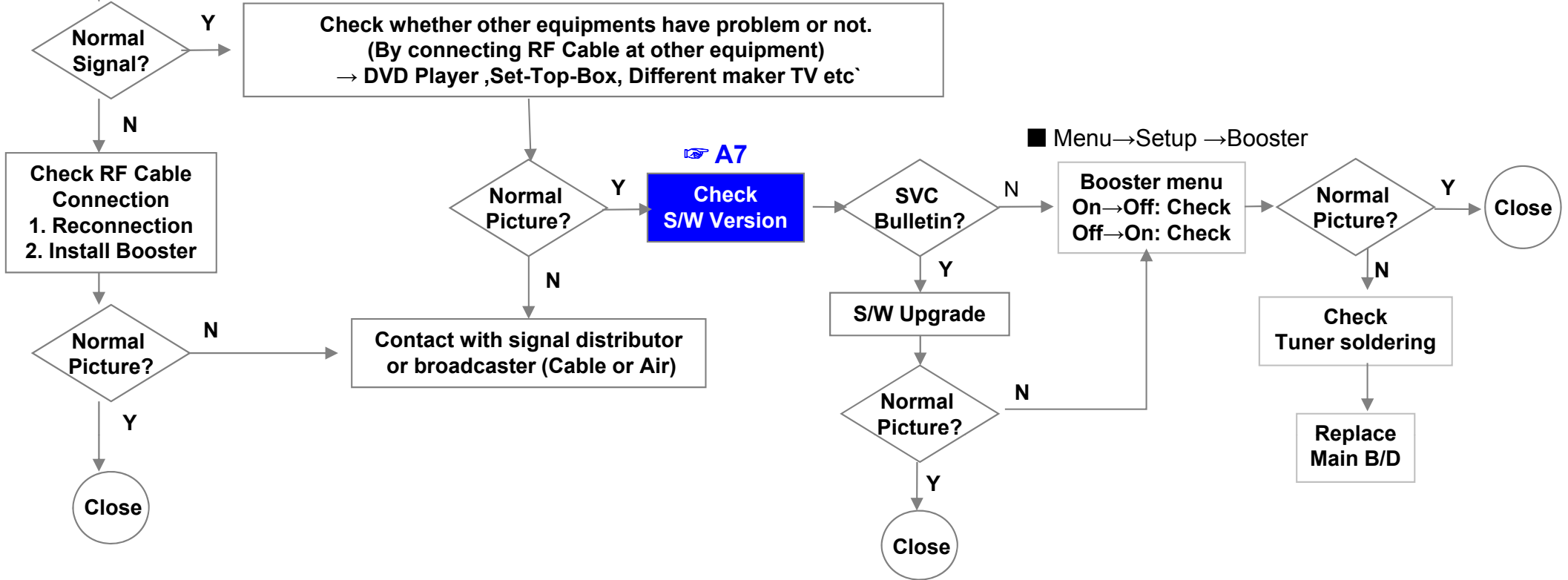

LCD TV	Error symptom	A. Picture Problem (DVB-S/S2)	Established date	2013. 11 .30	
		Tuning fail, Picture broken/ Freezing	Revised date		3/13

A6

Check RF Signal level

Check RF signal cable (DVB satellite signal or not)
 Check whether other equipments have problem or not.
 (By connecting RF Cable at other equipment)
 → Set-Top-Box, Different maker TV etc

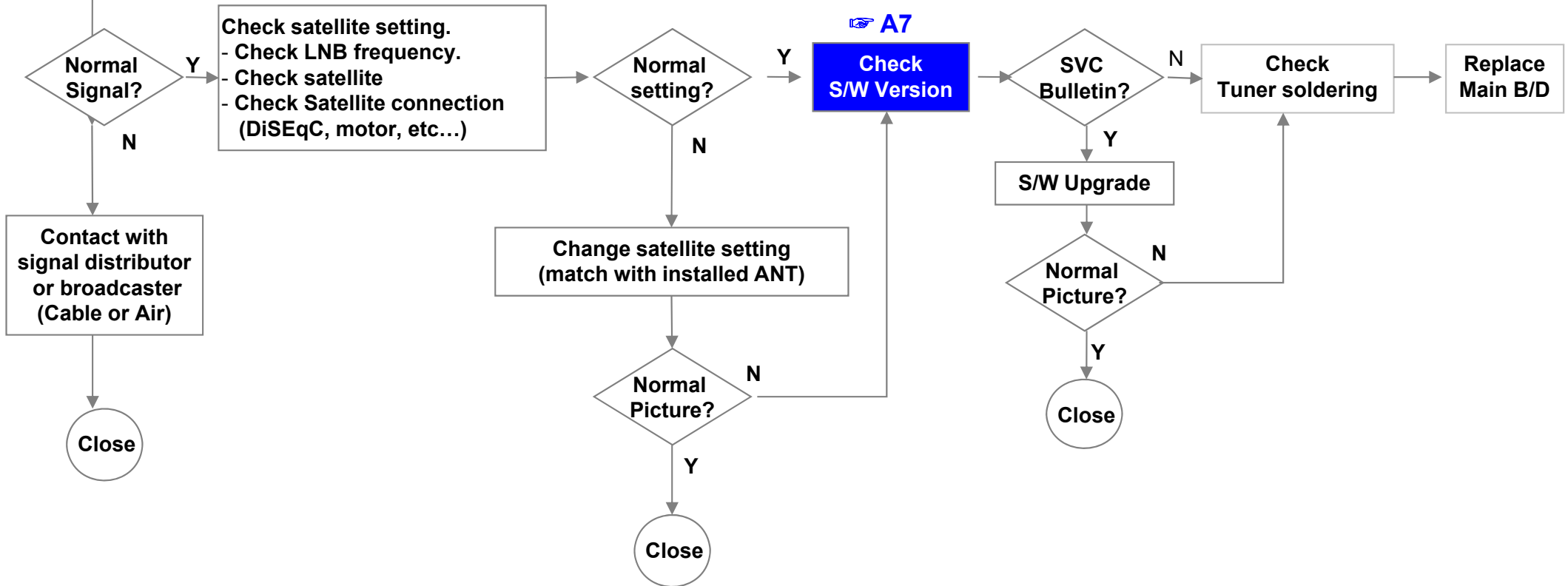

LCD TV	Error symptom	A. Video error	Established date	2013. 11 .30	
		Color error	Revised date		4/13

A8

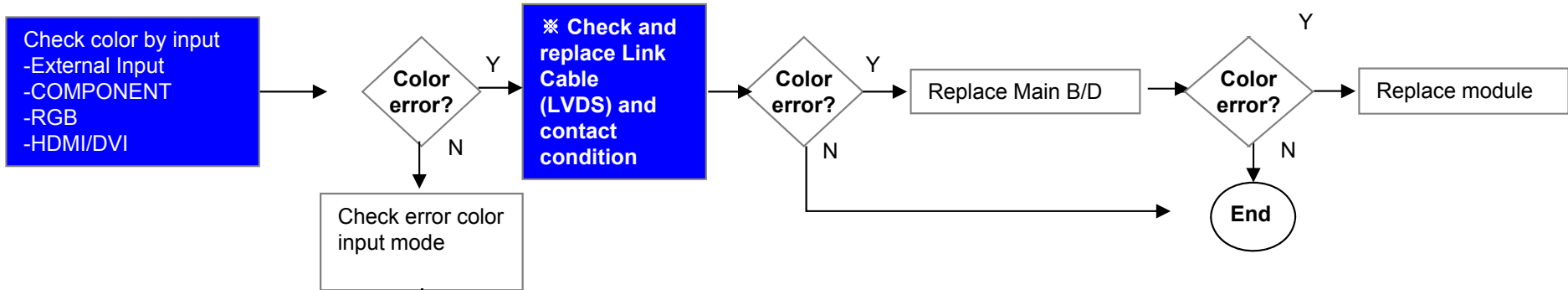

A12

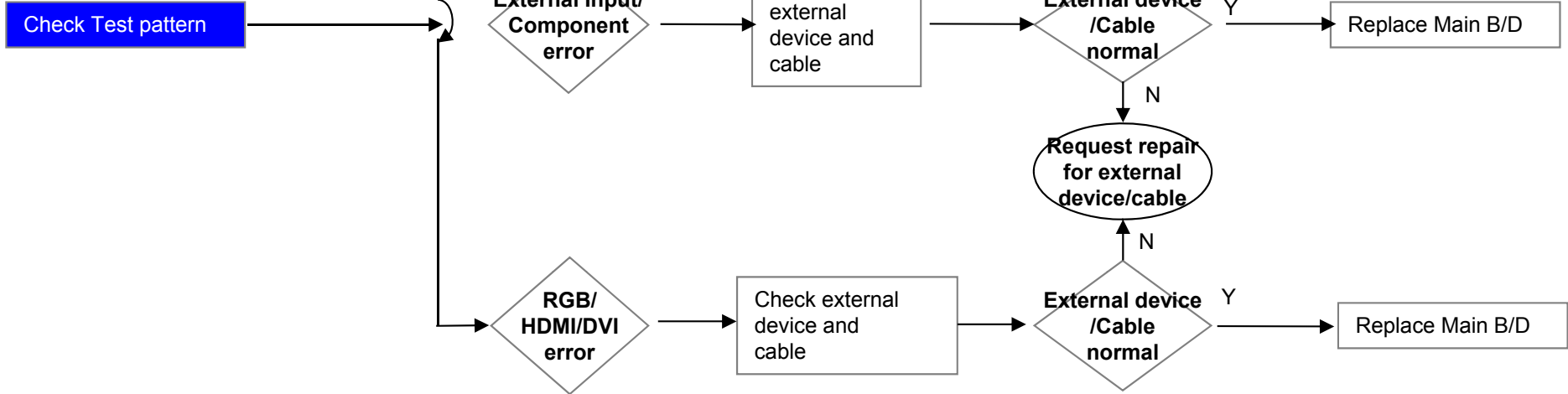

LCD TV	Error symptom	A. Video error	Established date	2013. 11 .30	
		Vertical / Horizontal bar, residual image, light spot, external device color error	Revised date		5/13

Vertical/Horizontal bar, residual image, light spot

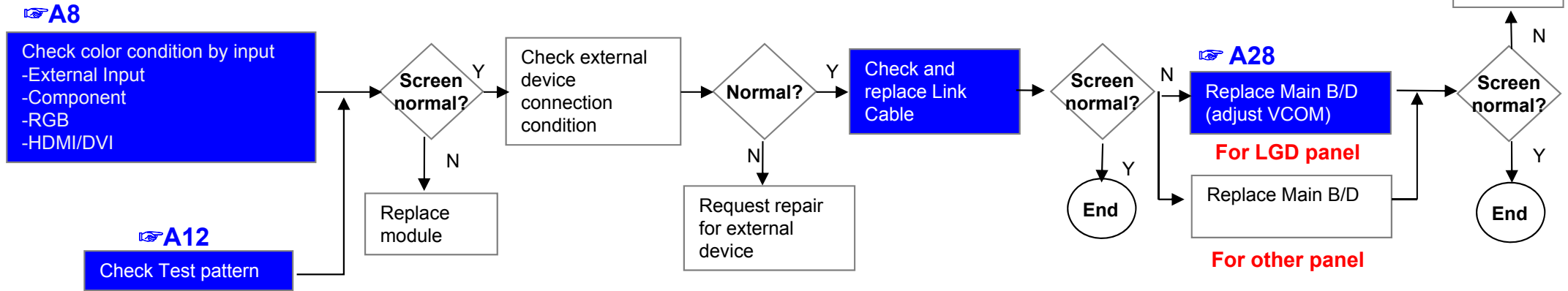

External device screen error-Color error

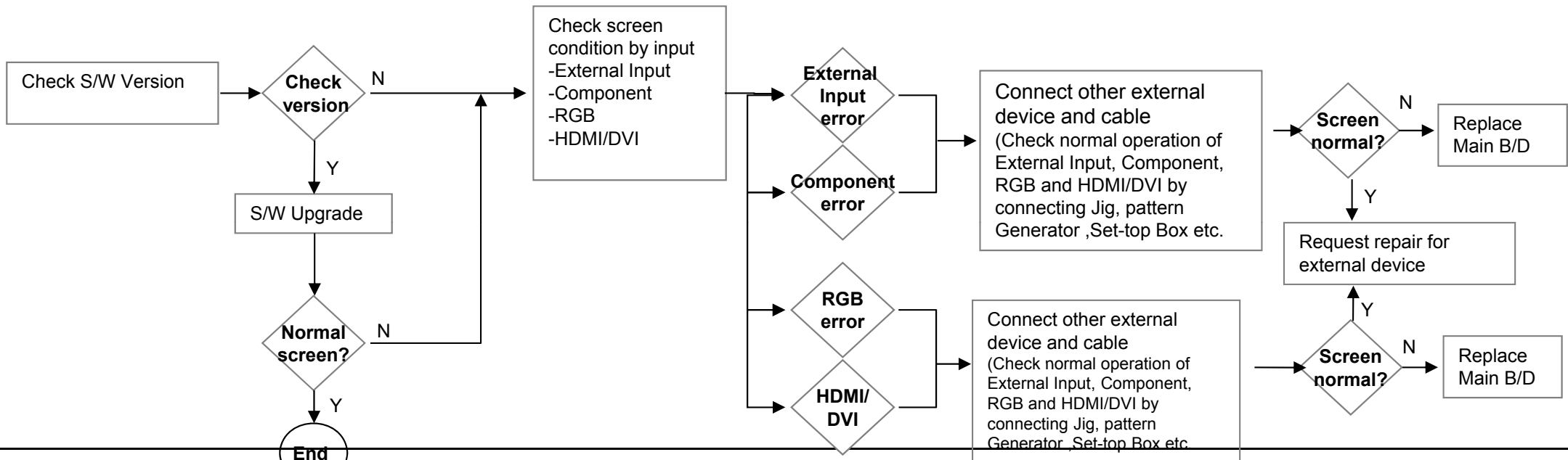

LCD TV	Error symptom	B. Power error	Established date	2013. 11 .30	
		No power	Revised date		6/13

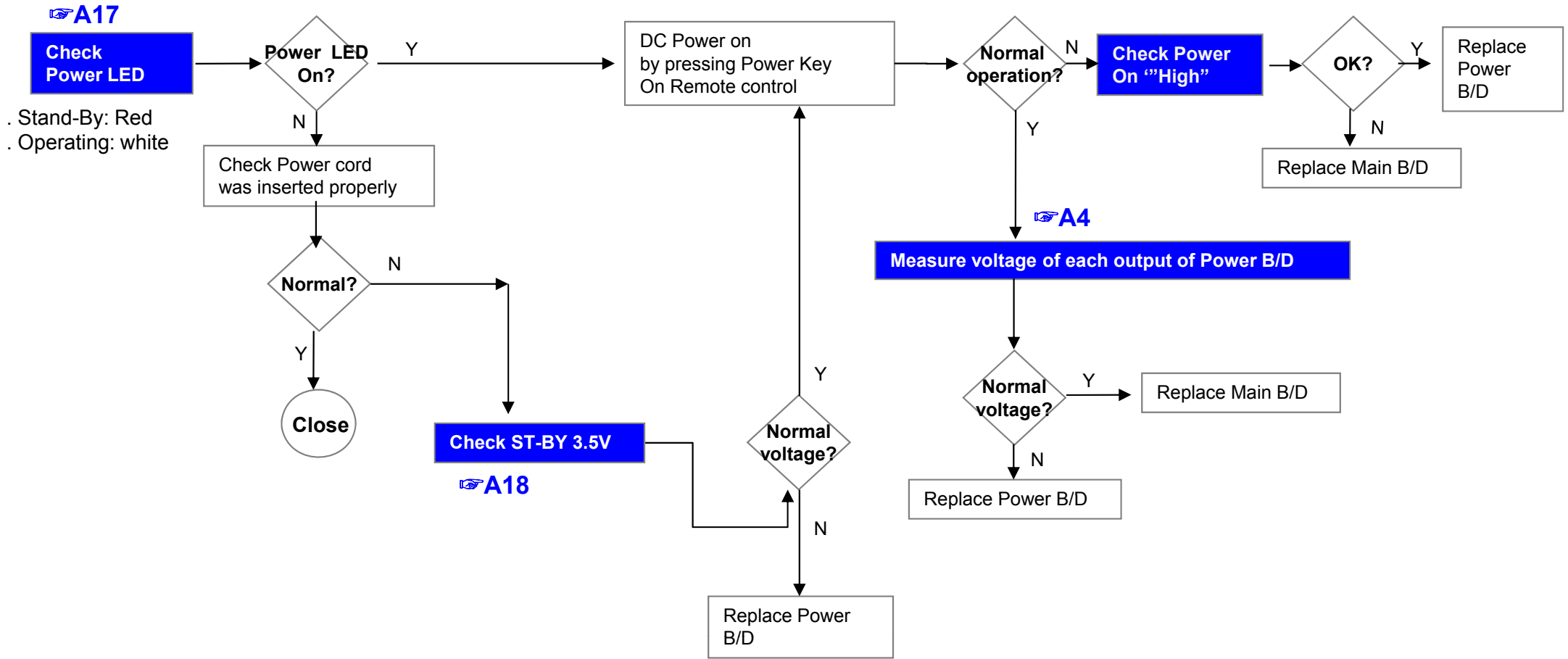

LCD TV	Error symptom	B. Power error	Established date	2013. 11 .30	
		Off when on, off while viewing, power auto on/off	Revised date		7/13

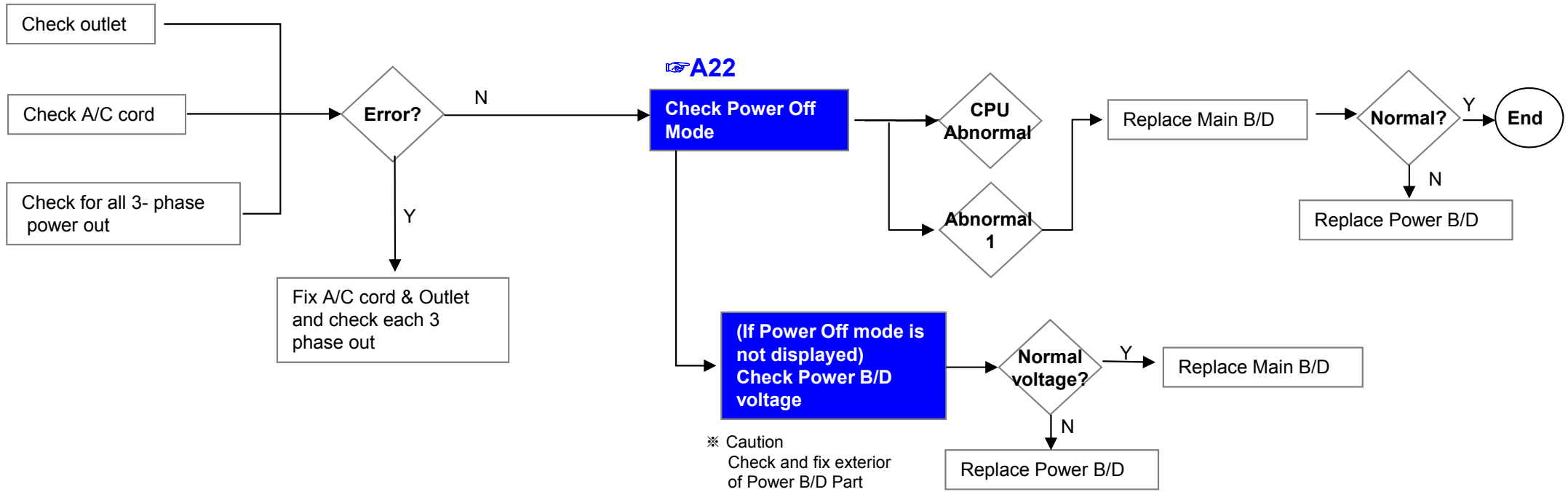

* Please refer to the all cases which can be displayed on power off mode.

Status	Power off List	Explanation
Normal	"POWEROFF_REMOTEKEY"	Power off by REMOTE CONTROL
	"POWEROFF_OFFTIMER"	Power off by OFF TIMER
	"POWEROFF_SLEEPTIMER"	Power off by SLEEP TIMER
	"POWEROFF_INSTOP"	Power off by INSTOP KEY
	"POWEROFF_AUTOOFF"	Power off by AUTO OFF
	"POWEROFF_ONTIMER"	Power off by ON TIMER
	"POWEROFF_RS232C"	Power off by RS232C
	"POWEROFF_RESREC"	Power off by Reserved Record
	"POWEROFF_RECEND"	Power off by End of Recording
	"POWEROFF_SWDOWN"	Power off by S/W Download
	"POWEROFF_UNKNOWN"	Power off by unknown status except listed case
Abnormal	"POWEROFF_ABNORMAL1"	Power off by abnormal status except CPU trouble
	"POWEROFF_CPUABNORMAL"	Power off by CPU Abnormal

LCD TV	Error symptom	C. Audio error	Established date	2013. 11 .30	
		No audio/ Normal video	Revised date		8/13

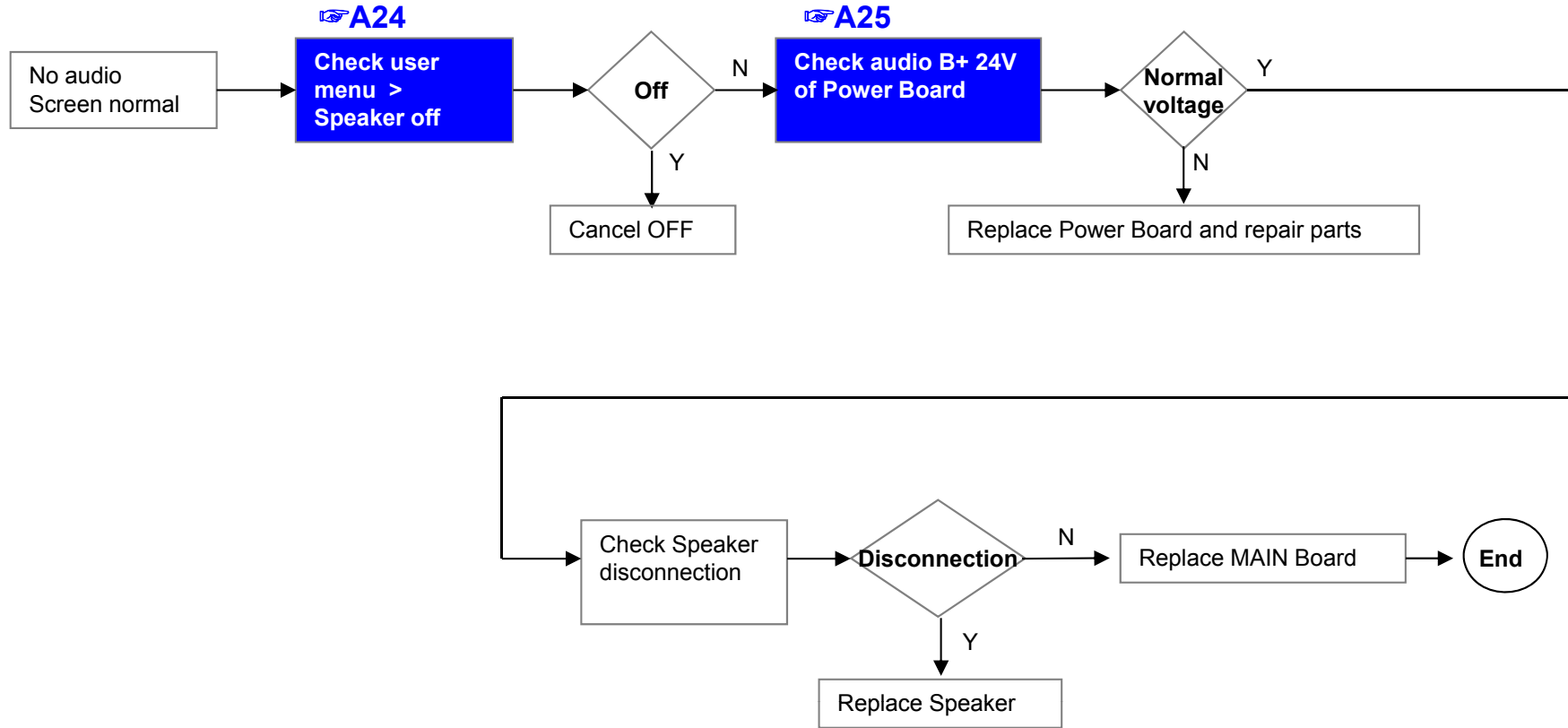

LCD TV	Error symptom	C. Audio error	Established date	2013. 11 .30	
		Wrecked audio/ discontinuation/noise	Revised date		9/13

→ abnormal audio/discontinuation/noise is same after “Check input signal” compared to No audio

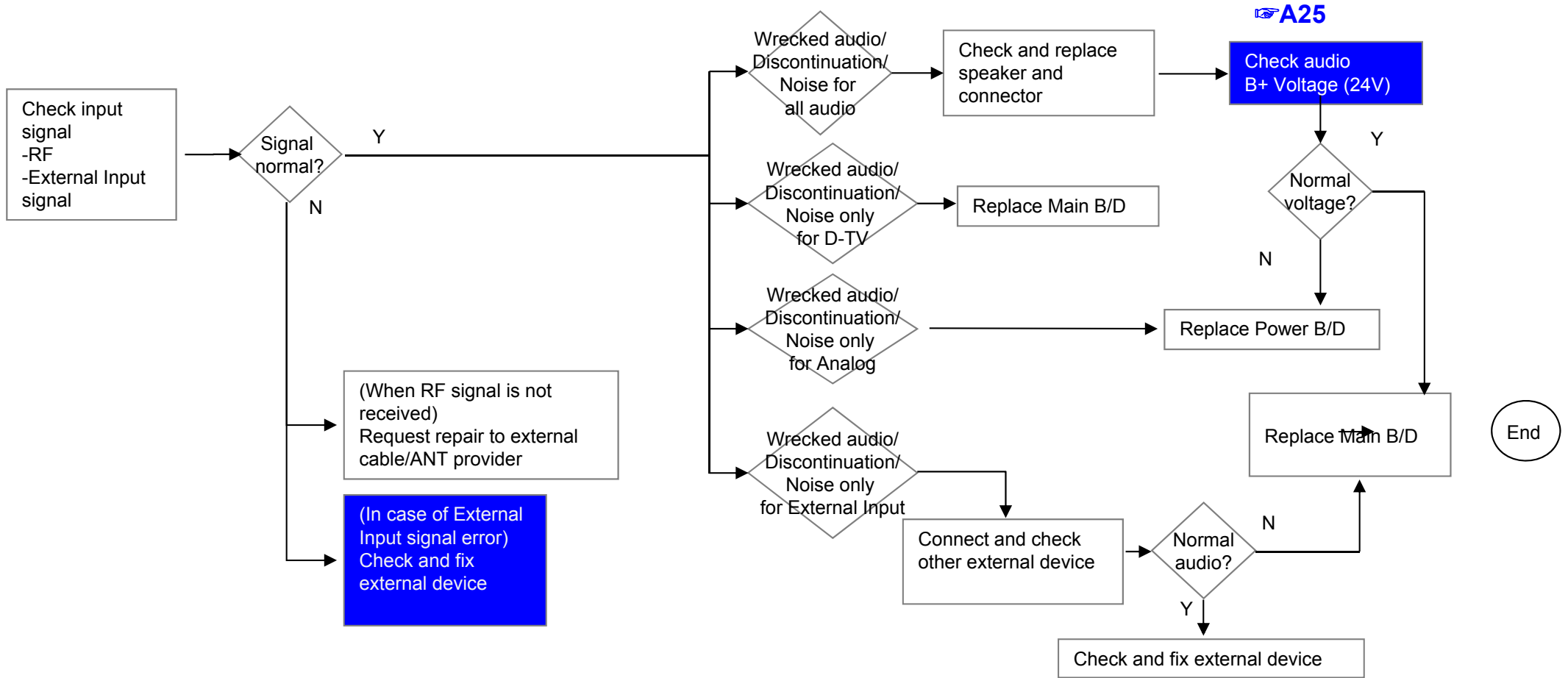

LCD TV	Error symptom	D. General Function Problem	Established date	2013. 11 .30	
		Remote control & Local switch checking	Revised date		10/13

1. Remote control(R/C) operating error

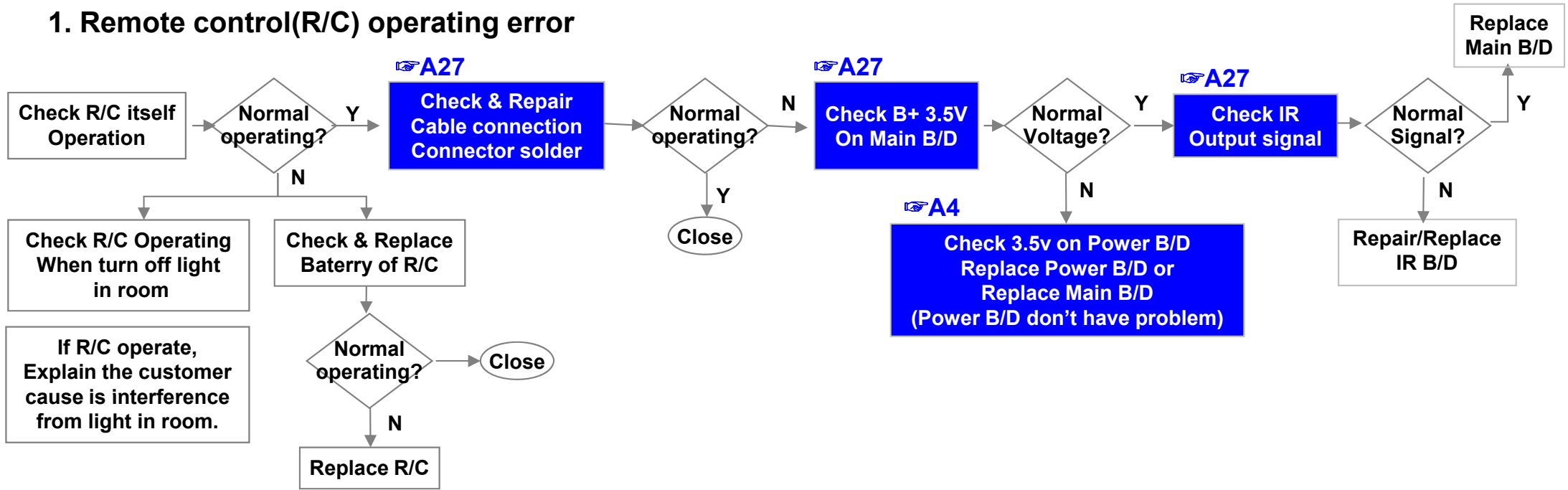

LCD TV	Error symptom	D. Function error	Established date	2013. 11 .30	
		External device recognition error	Revised date		11/13

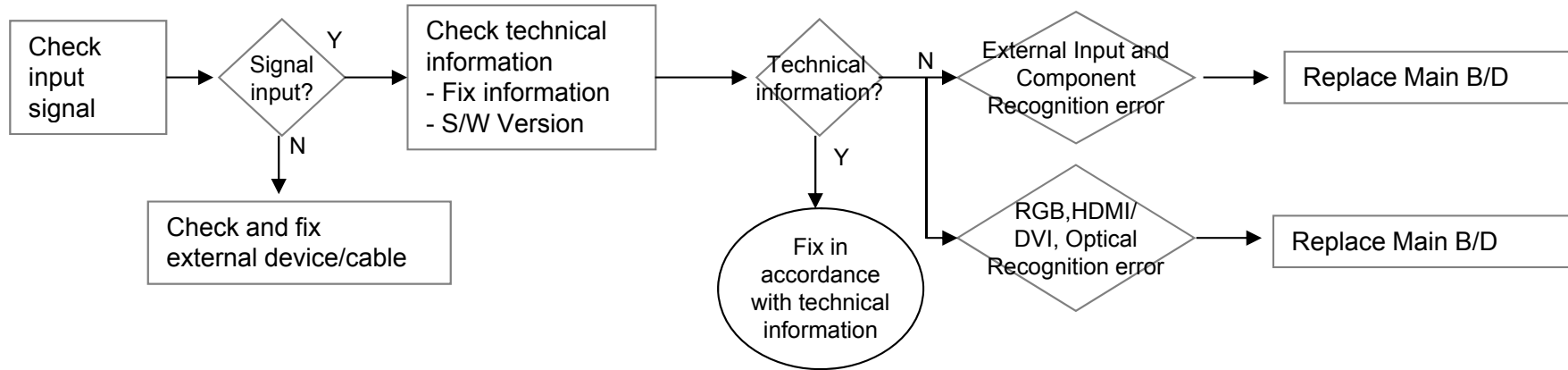

LCD TV	Error symptom	E. Noise	Established date	2013. 11 .30	
		Circuit noise, mechanical noise	Revised date		12/13

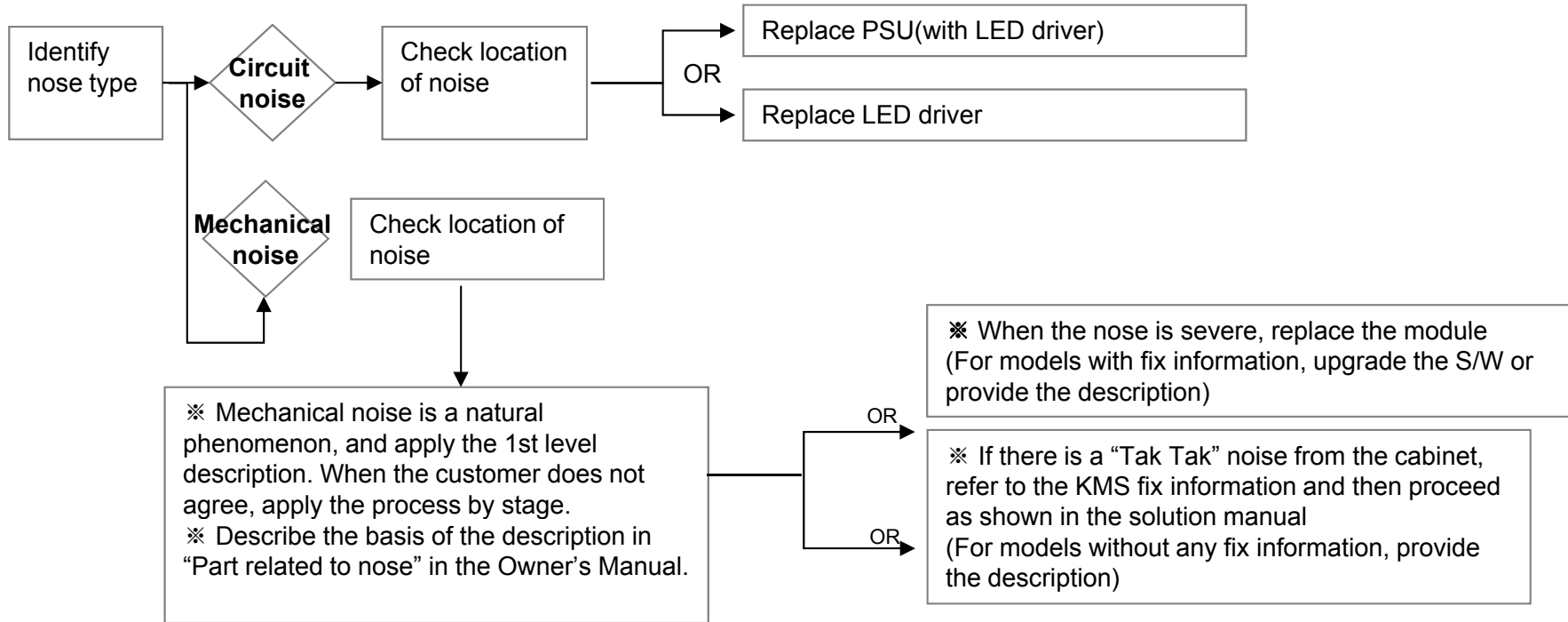

LCD TV	Error symptom	F. Exterior defect	Established date	2013. 11 .30	
		Exterior defect	Revised date		13/13

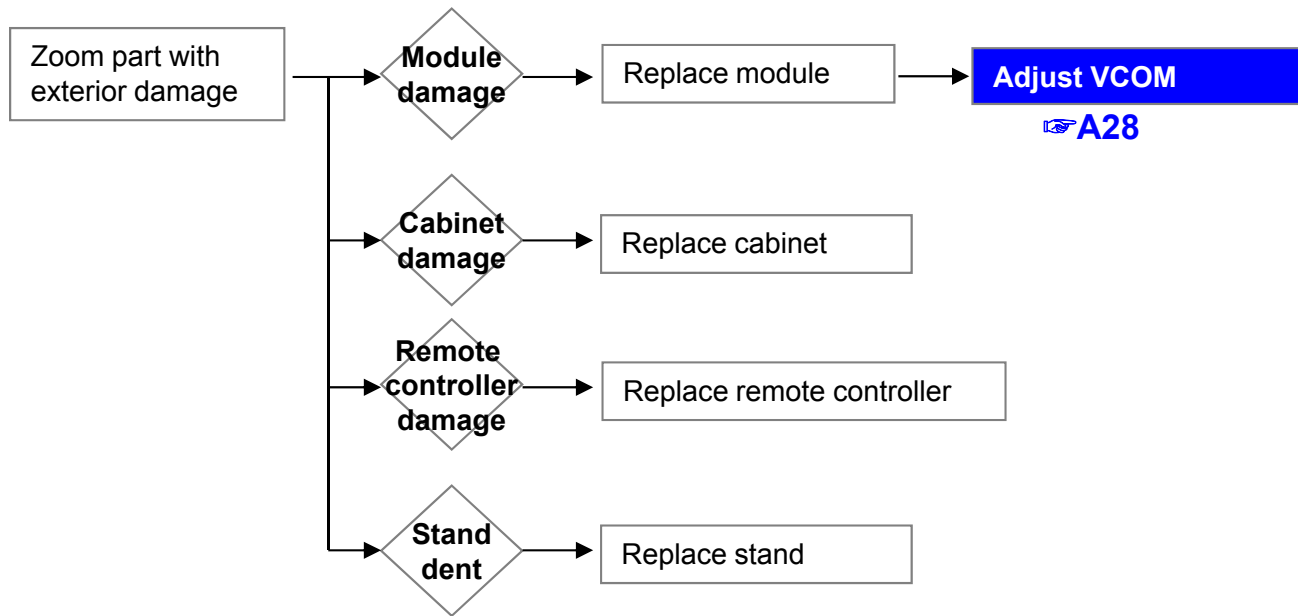

Contents of LCD TV Standard Repair Process Detail Technical Manual

Continued from previous page

No.	Error symptom	Content	Page	Remarks
21	B. Power error_No power	Check front display LED	A17	
22		Check power input Voltage & ST-BY 5V	A18	
23		Checking method when power is ON	A18	
24		POWER BOARD voltage measuring method	A5	
25				
26	B. Power error_Off when on, off while viewing	POWER OFF MODE checking method	A22	
27	B. Power error_Off when on, off while viewing	POWER BOARD PIN voltage checking method	A18	
28	C. Audio error_No audio/Normal video	Checking method in menu when there is no audio	A24	
29		Voltage and speaker checking method when there is no audio	A25	
30	C. Audio error_Wrecked audio/discontinuation	Voltage and speaker checking method in case of audio error	A25	
31	D. Function error_ No response in remote controller, key error	Remote controller operation checking method	A27	
32	D. VCOM Adjustment	Sequence of the Vcom adjustment	A28	

Standard Repair Process Detail Technical Manual

LCD TV	Error symptom	A. Video error_No video/Normal audio	Established date	2013. 11 .30	
	Content	Check White Balance value	Revised date		A4

<ALL MODELS>

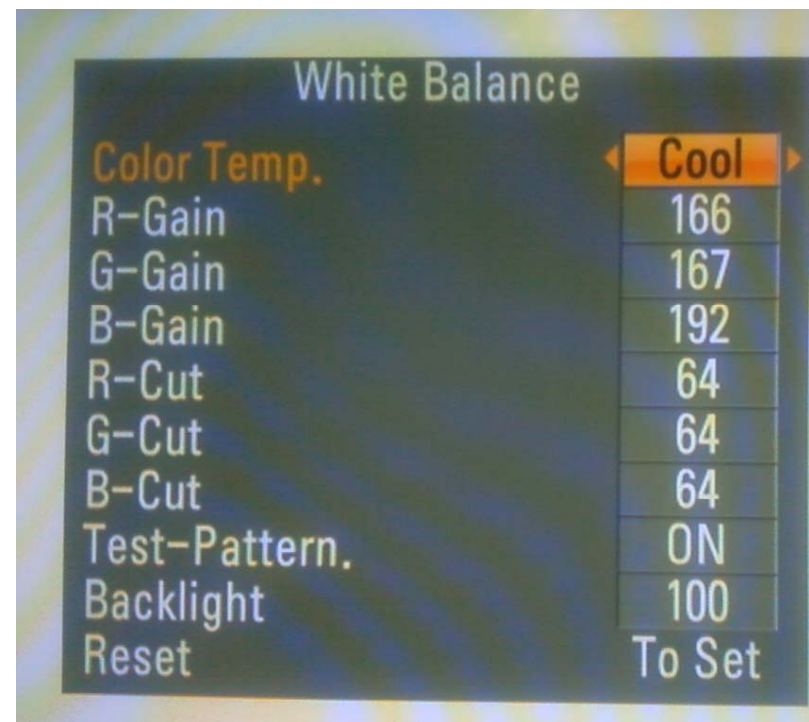
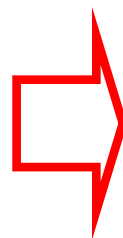
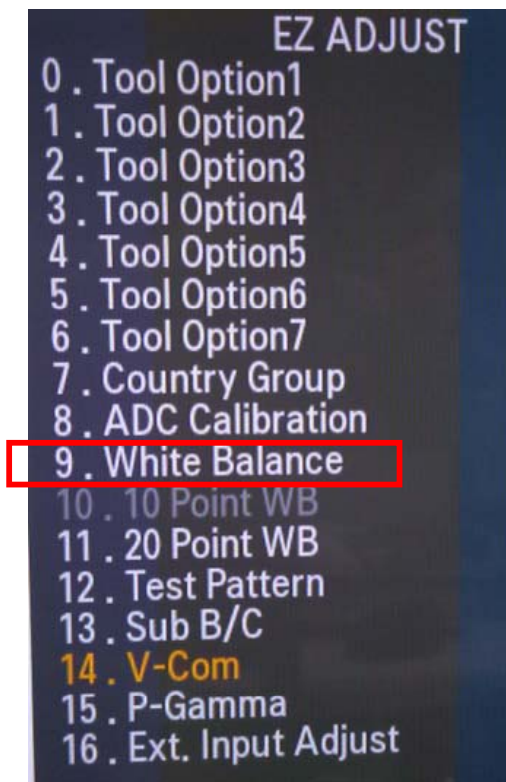

Entry method

1. Press the ADJ button on the remote controller for adjustment.
2. Enter into White Balance of item 9.
3. After recording the R, G, B (GAIN, Cut) value of Color Temp (Cool/Medium/Warm), re-enter the value after replacing the MAIN BOARD.

Standard Repair Process Detail Technical Manual

LCD TV	Error symptom	A. Video error_No video/ Audio	Established date	2013. 11 .30	
	Content	Power Board voltage measuring method	Revised date		A5

Direct LED

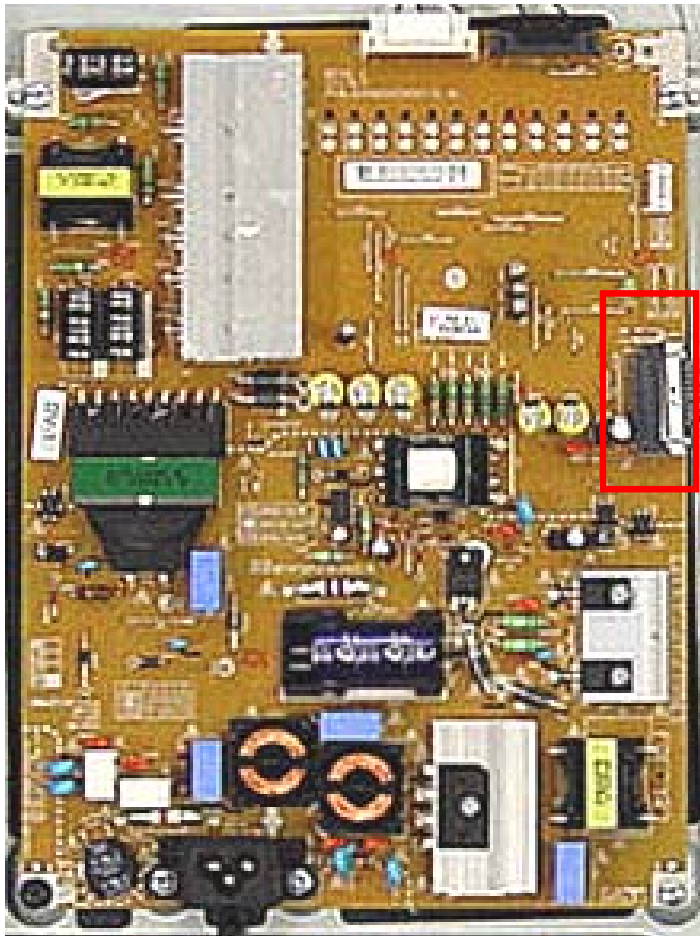

Check the DC 24V, 12V, 3.5V.

24 Pin (Power Board ↔ Main Board) - Common			
SMAW200-H24S5			
1	Power on	2	INV_ON
3	3.5V	4	PDIM #1
5	3.5V	6	3.5V
7	GND	8	PDIM #2
9	24V	10	24V
11	GND	12	GND
13	12V	14	12V
15	12V	16	24V
17	GND	18	GND
19	GND	20	GND
21	GND	22	L/DIM0_VS
23	L/DIM0_MOSI	24	L/DIM0_SCLK

Standard Repair Process Detail Technical Manual

LCD TV	Error symptom	A. Video error_Video error, video lag/stop	Established date	2013. 11 .30	
	Content	TUNER input signal strength checking method	Revised date		A6

<ALL MODELS>

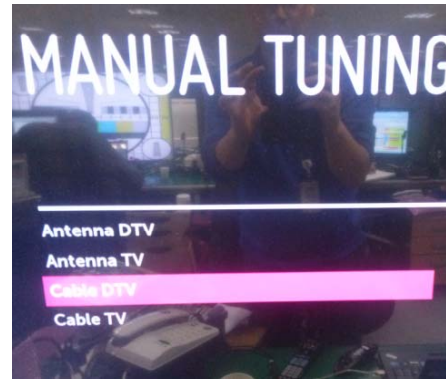

MENU → Channel → Manual → select channel



When the signal is strong, use the attenuator (-10dB, -15dB, -20dB etc.)



Standard Repair Process Detail Technical Manual

LCD TV	Error symptom	A. Video error_Video error, video lag/stop	Established date	2013. 11 .30	
	Content	LCD-TV Version checking method	Revised date		A7

<ALL MODELS>

1. Checking method for remote controller for adjustment

Version



Press the IN-START with the remote controller for adjustment

Standard Repair Process Detail Technical Manual

LCD TV	Error symptom	A. Video error _ Vertical/Horizontal bar, residual image, light spot	Established date	2013. 11 .30	
	Content	LCD TV connection diagram (1)	Revised date		A8

<ALL MODELS>



As the part connecting to the external input, check the screen condition by signal

Standard Repair Process Detail Technical Manual

LCD TV	Error symptom	A. Video error_Video error, video lag/stop	Established date	2013. 11 .30	
	Content	TUNER checking part	Revised date		A9

<ALL MODELS>

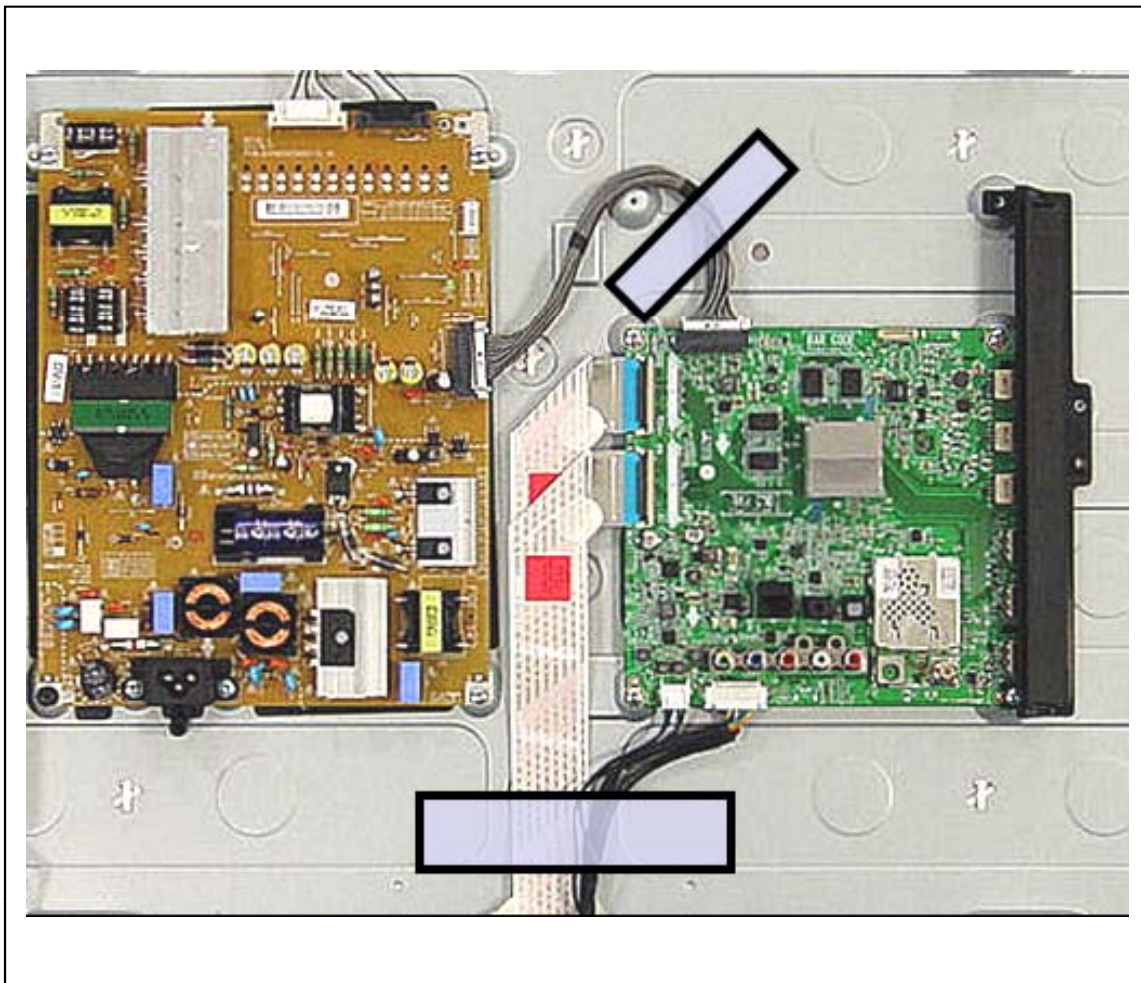

Checking method:

1. Check the signal strength or check whether the screen is normal when the external device is connected.
2. After measuring each voltage from power supply, finally replace the MAIN BOARD.

Standard Repair Process Detail Technical Manual

LCD TV	Error symptom	A. Video error_Color error	Established date	2013. 11 .30	
	Content	Adjustment Test pattern - ADJ Key	Revised date		A12



- EZ ADJUST**
- 0 . Tool Option1
 - 1 . Tool Option2
 - 2 . Tool Option3
 - 3 . Tool Option4
 - 4 . Tool Option5
 - 5 . Tool Option6
 - 6 . Tool Option7
 - 7 . Country Group
 - 8 . ADC Calibration
 - 9 . White Balance
 - 10 . 10 Point WB
 - 11 . 20 Point WB
 - 12 . Test Pattern
 - 13 . Sub B/C
 - 14 . V-Com
 - 15 . P-Gamma
 - 16 . Ext. Input Adjust



You can view 6 types of patterns using the ADJ Key

Checking item : 1. Defective pixel 2. Residual image 3. MODULE error (ADD-BAR,SCAN BAR..) 4.Video error (Classification of MODULE or Main-B/D!)



Solder defect, CNT Broken

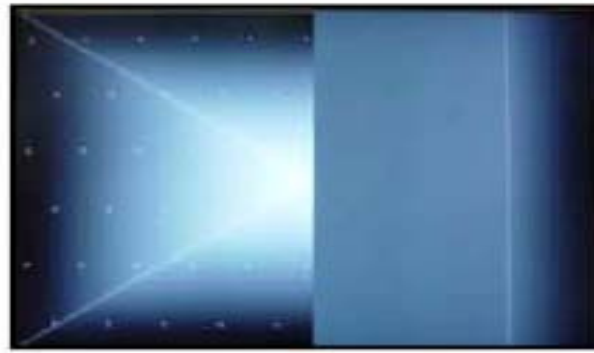

Solder defect, CNT Broken

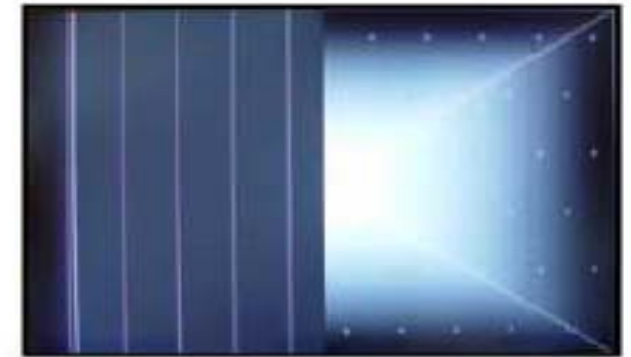

Solder defect, CNT Broken



Solder defect, CNT Broken

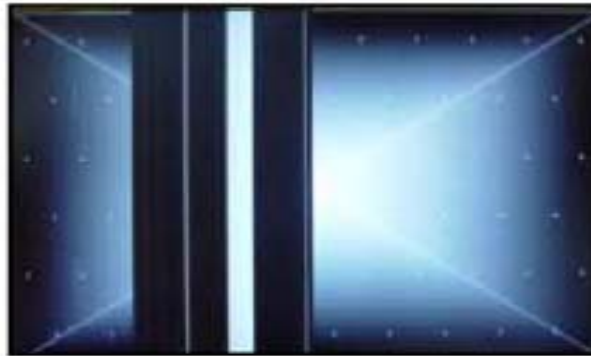

Solder defect, CNT Broken



Abnormal Power Section

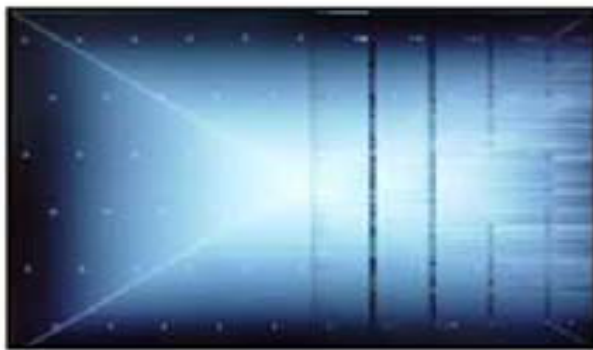

Solder defect, Short/Crack



Abnormal Power Section



Solder defect, Short/Crack



Abnormal Power Section



Abnormal Power Section



Solder defect, Short/Crack



Solder defect, Short/Crack



Fuse Open, Abnormal power section



Abnormal Display



GRADATION



Noise

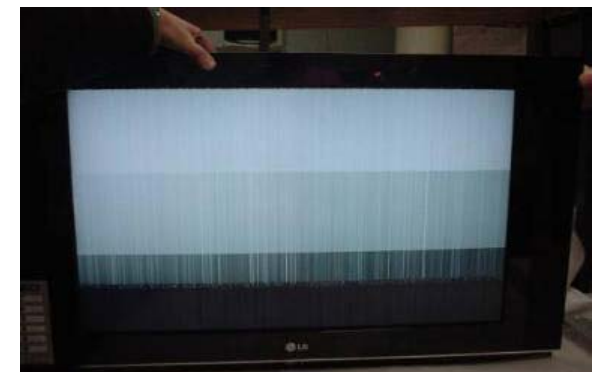

GRADATION



No Light



Dim Light



Dim Light

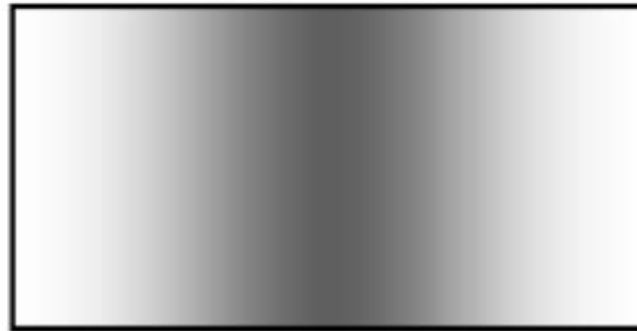

Dim Light



No picture/Sound Ok



Panel Mura, Light leakage



Panel Mura, Light leakage



Press damage

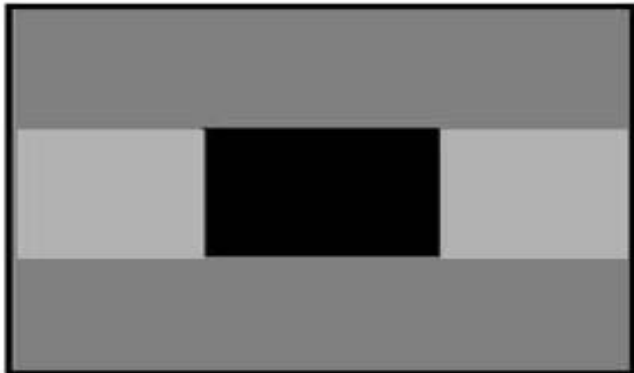

Crosstalk



Press damage



Crosstalk



Press damage

Un-repairable Cases

In this case please exchange the module.

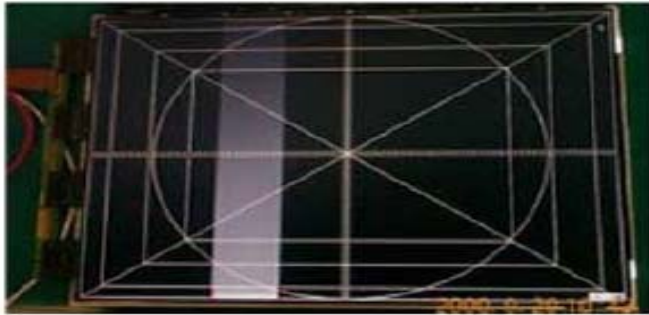

Vertical Block
Source TAB IC Defect



Vertical Line
Source TAB IC Defect



Vertical Block
Source TAB IC Defect



Horizontal Block
Gate TAB IC Defect



Horizontal Block
Gate TAB IC Defect

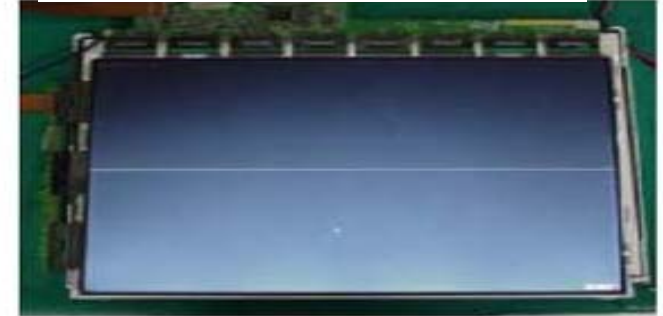

Horizontal line
Gate TAB IC Defect

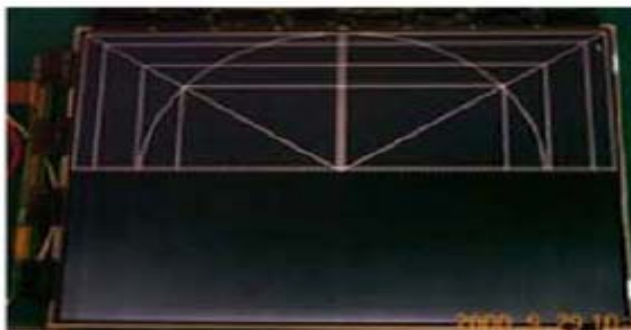

Horizontal Block
Gate TAB IC Defect

Un-repairable Cases
In this case please exchange the module.

Standard Repair Process Detail Technical Manual

LCD TV	Error symptom	B. Power error _No power	Established date	2013. 11 .30	
	Content	Check front display LED	Revised date		A17



ST-BY condition: On
Power ON condition: Off

Standard Repair Process Detail Technical Manual

LCD TV	Error symptom	B. Power error _No power	Established date	2013. 11 .30	
	Content	Check power input voltage and ST-BY 3.5V	Revised date		A18

Checking method when power is ON

When st-by, only 3.5V is normally on.

Direct LED

Check the DC 24V, 12V, 3.5V.

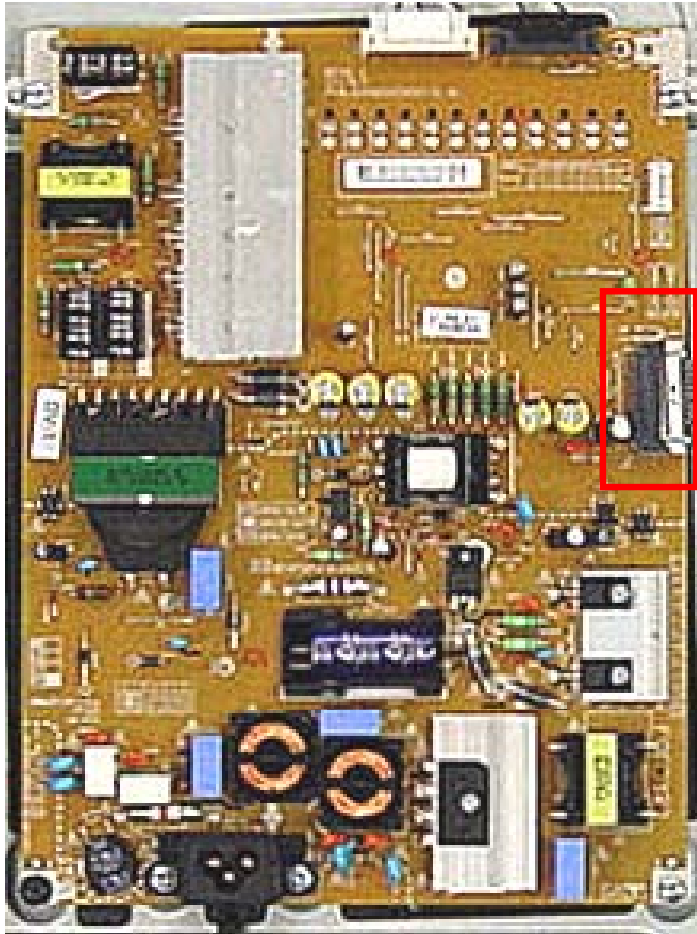

24 Pin (Power Board ↔ Main Board) - Common

SMAW200-H24S5

1	Power on	2	INV_ON
3	3.5V	4	PDIM #1
5	3.5V	6	3.5V
7	GND	8	PDIM #2
9	24V	10	24V
11	GND	12	GND
13	12V	14	12V
15	12V	16	24V
17	GND	18	GND
19	GND	20	GND
21	GND	22	L/DIM0_VS
23	L/DIM0_MOSI	24	L/DIM0_SCLK

Standard Repair Process Detail Technical Manual

LCD TV	Error symptom	B. Power error _Off when on, off whiling viewing	Established date	2013. 11 .30	
	Content	POWER OFF MODE checking method	Revised date		A22

<ALL MODELS>

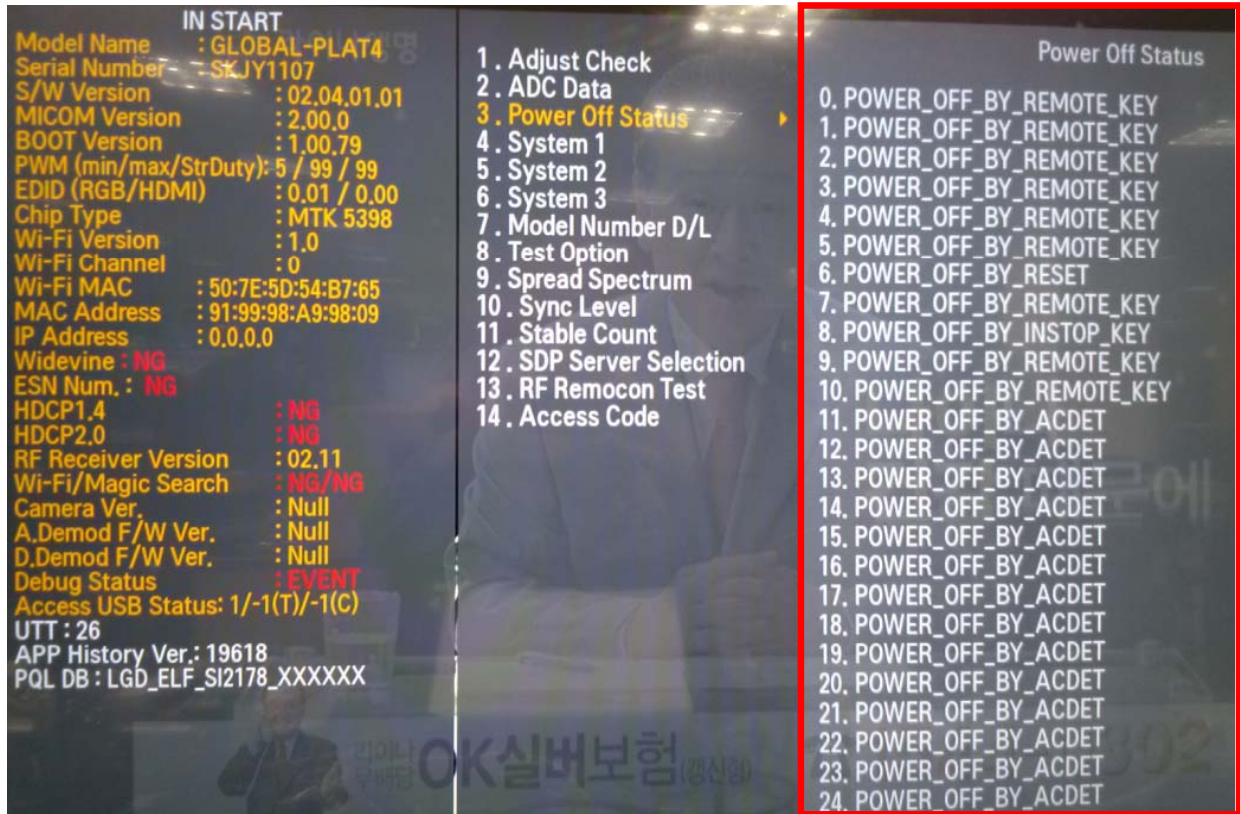

Entry method

1. Press the IN-START button of the remote controller for adjustment
2. Check the entry into adjustment item 3

Standard Repair Process Detail Technical Manual

LCD TV	Error symptom	C. Audio error_No audio/Normal video	Established date	2013. 11 .30	
	Content	Checking method in menu when there is no audio	Revised date		A24

<ALL MODELS>

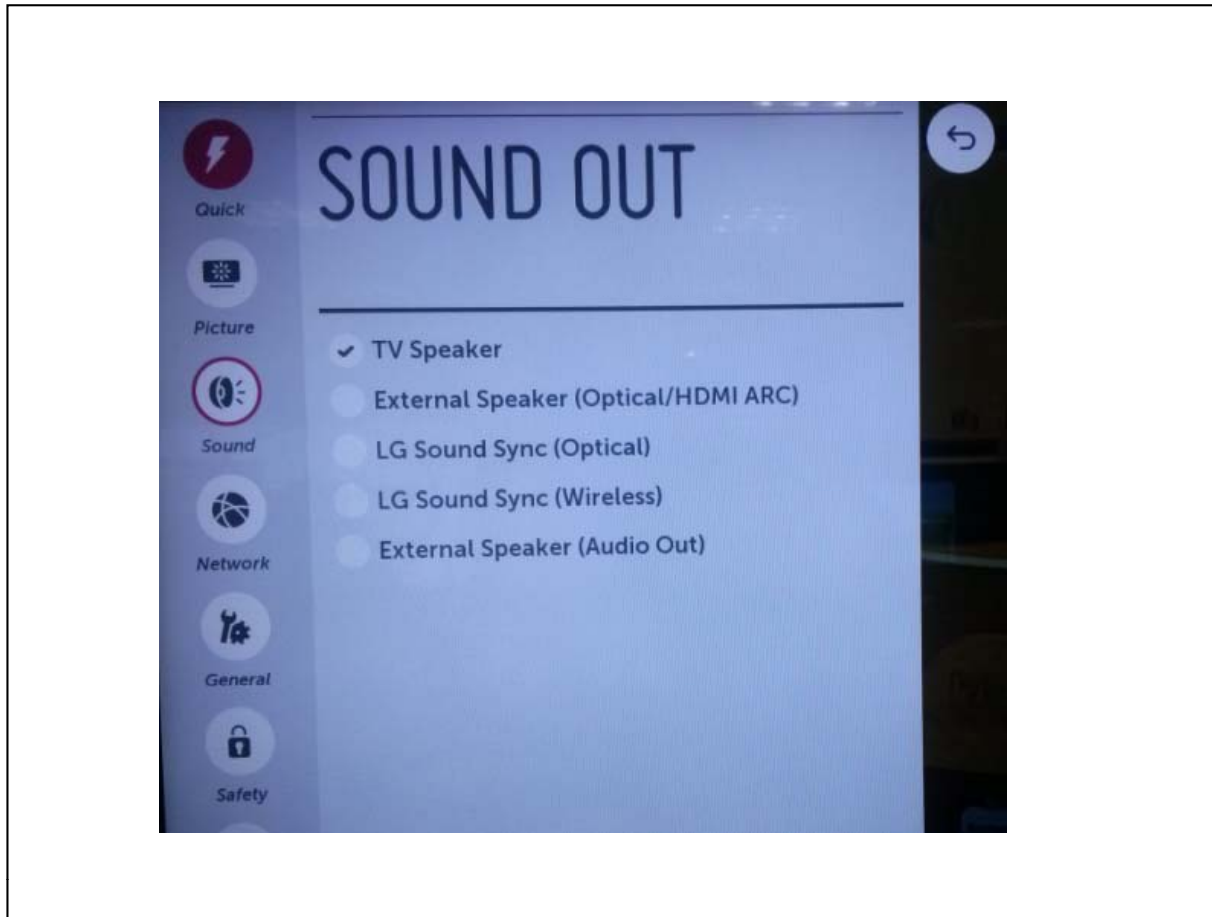

Checking method

1. Press the MENU button on the remote controller
2. Select the AUDIO function of the Menu
3. Select TV Speaker Or Other

Standard Repair Process Detail Technical Manual

LCD TV	Error symptom	C. Audio error_No audio/Normal video	Established date	2013. 11 .30	
	Content	Voltage and speaker checking method when there is no audio	Revised date		A25

<ALL MODELS>



24 Pin (Power Board ↔ Main Board) - 공통			
SMAW200-H24S5			
1	Power on	2	INV_ON
3	3.5V	4	PDIM #1
5	3.5V	6	3.5V
7	GND	8	PDIM #2
9	24V	10	24V
11	GND	12	GND
13	12V	14	12V
15	12V	16	24V
17	GND	18	GND
19	GND	20	GND
21	GND	22	L/DIM0_VS
23	L/DIM0_MOSI	24	L/DIM0_SCLK

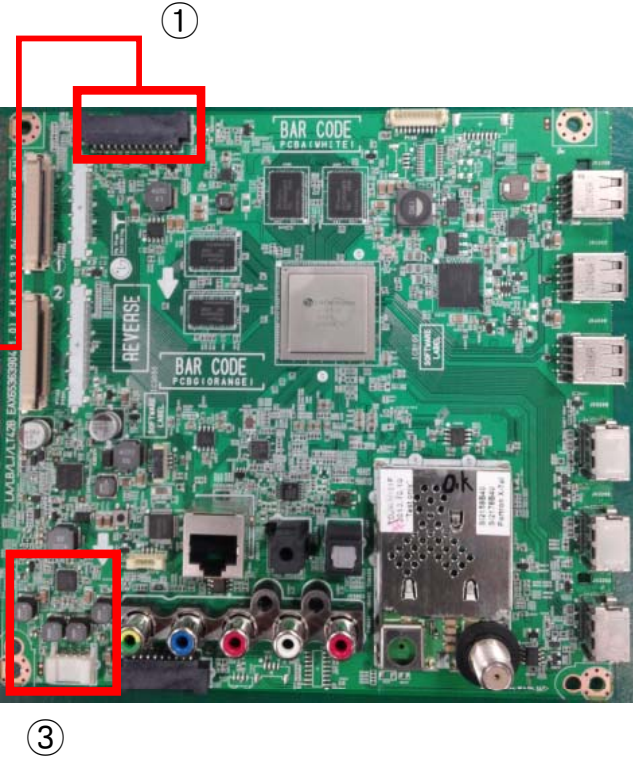

Checking order when there is no audio

- ① Check the contact condition of or 24V connector of Main Board
- ② Measure the 24V input voltage supplied from Power Board
(If there is no input voltage, remove and check the connector)
- ③ Connect the tester RX1 to the speaker terminal and if you hear the "Chik Chik" sound when you touch the GND and output terminal, the speaker is normal.

Standard Repair Process Detail Technical Manual

LCD TV	Error symptom	D. Function error_ No response in remote controller, key error	Established date	2013. 11 .30	
	Content	Remote controller operation checking method	Revised date		A27

<ALL MODELS>



①

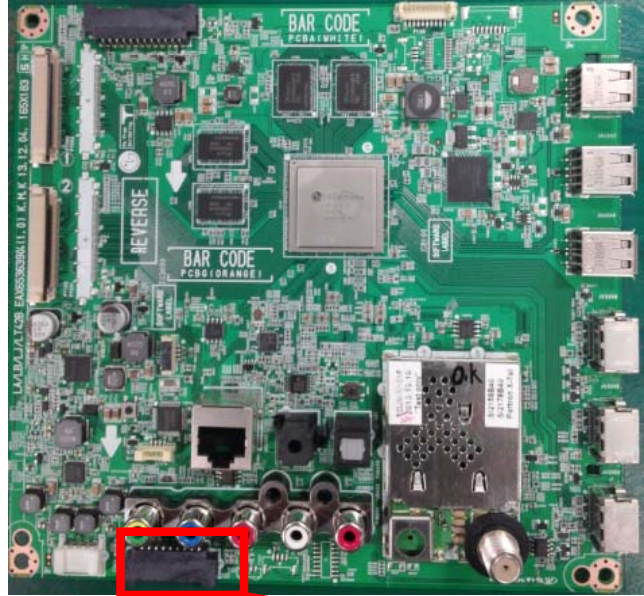

②

④

③

P4000	
1	GND
2	3.5V_WOL
3	BT_RESET
4	USB_DM
5	NC
6	USB_DP
7	WOL
8	GND
9	EYE_SDA
10	GND
11	EYE_SCL
12	KEY1
13	GND
14	KEY2
15	IR
16	3.5V_ST
17	LED_R
18	GND

Checking order

- 1, 2. Check IR cable condition between IR & Main board.
3. Check the st-by 3.5V on the terminal 16.
4. When checking the Pre-Amp when the power is in ON condition, it is normal when the Analog Tester needle moves slowly, and defective when it does not move at all.

Standard Repair Process Detail Technical Manual

LCD TV	Error symptom	D. VCOM Adjustment	Established date	2013. 11 .30	
	Content	Sequence of the Vcom adjustment	Revised date		A28

1. Case

- LCD module change
- T-Con board change

2. Equipment

- Service Remote controller

3. Adjust sequence

- Press the 'adj' key
- select V-COM
- As pushing the right or the left button on the remote controller, And find the V-COM value Which is no or minimized the Flicker.

(If there is no flicker at default value, Press the exit key and finish the VCOM adjustment.)

- Push the OK key to store the value. Then the message "Saving OK" is pop.
- Press the exit key to finish V-COM adjustment.

