

SERVICE MANUAL (TROUBLESHOOTING)

ORIGINAL MANUAL ISSUE DATE: 2023/11

DISCLAIMER: USE AT OWN RISK. SONY AND ITS AFFILIATES ARE NOT LIABLE FOR ANY DAMAGE OR INJURY CAUSED TO ANY DIGITAL ELECTRONIC EQUIPMENT, PERSON, OR PROPERTY, WHICH OCCURS DUE TO USE OF THE TOOLS, PARTS, DOCUMENTATION, OR OTHER MATERIALS HEREIN PROVIDED, WHETHER FOR REPAIR, DIAGNOSIS, MAINTENANCE, MODIFICATION, OR OTHERWISE, INCLUDING BUT NOT LIMITED TO: ANY INDIRECT, INCIDENTAL, SPECIAL, OR CONSEQUENTIAL DAMAGES; ANY LOSS OF DATA, PRIVACY OR PROFITS; OR ANY INABILITY TO USE, OR REDUCED FUNCTIONALITY OF, THE DIGITAL ELECTRONIC EQUIPMENT.

The manual is intended for a trained professional and the use of the manual is at your own risk.

9-888-744-21

LCD TV

SONY®

Sony EMCS (Malaysia) Sdn. Bhd. HES-M

© 2023.11

MODEL LIST

THIS SERVICE MANUAL CONTAINS TROUBLESHOOTING INFORMATION FOR BELOW REGIONS AND MODELS:



MODEL

FW-43BZ35F

FW-49BZ35F

TABLE OF CONTENTS

<u>Section Title</u>	<u>Page</u>
1. SAFETY NOTES	4
2. SELF DIAGNOSTIC FUNCTION	13
3. TROUBLESHOOTING	16
4. DIAGRAMS	79

Please refer Service Manual (Disassembly) for below information:

- Dissassy and Removal Caution
- Wire Dressing
- Circuit Board Location
- Exploded Views and Parts List

Note: Pictures provided in this manual may have difference from actual sets.

SAFETY NOTES

1-1. Warnings and Caution.

- 1) CAUTION :These servicing instructions are for use by qualified service personnel only.
- 2) To reduce the risk of electric shock, do not perform any servicing other than that stated in the operating instructions unless you are qualified to do so.
- 3) WARNING!!: An isolation transformer should be used during any service to avoid possible shock hazard, because of live chassis. The chassis of this receiver is directly connected to the ac power line. The replaceable fuse should be in the neutral of the mains supply. When replacing the fuse, the mains must be disconnected to de-energize the phase conductors. (*Except AC ADAPTOR, because it does not carry out replacing an internal fuse.)
- 4) CARRYING THE TV: be sure to follow these guidelines to protect your property and avoid causing serious injury:
 - Carry the TV with an adequate number of people; larger size TVs require two or more people.
 - Correct hand placement while carrying the TV is very important for safety and to avoid damages.
- 5) SAFETY-RELATED COMPONENT WARNING!!: Components identified by shading and  mark on the exploded views, and in the parts list are critical for safe operations. Replace these components with Sony parts whose part numbers appear as shown in this manual or in supplements published by Sony. Circuit adjustments that are critical for safe operations are identified in this manual. Follow these procedures whenever critical components are replaced, or improper operation is suspected.

6) IMPORTANT REMINDER FOR TV MAIN BOARD REPLACEMENT:

It is mandatory for service centers to confirm the TV's system information after each repair is carried out with Main board replacement. Whenever a TV Main board is replaced, the correct TV Model and Serial number must be reinserted into memory. This is a MANDATORY procedure that each service center must apply.

1-2. Caution Handling of LCD Panel.

When repairing the LCD Panel, make sure you are grounded with a wrist band. When repairing the LCD Panel on the wall, the panel must be secured using the 4 mounting holes on the rear cover.

- 1) Do not press the panel or frame edge to avoid the risk of electric shock.
- 2) Do not scratch or press on the panel with any sharp objects.
- 3) Do not leave the module in high temperature or in areas of high humidity for an extended period.
- 4) Do not expose the LCD panel to direct sunlight.
- 5) Avoid contact with water. It may cause short circuit within the module.
- 6) Disconnect the AC power when replacing the backlight.
- 7) Always clean the LCD panel with a soft cloth material.
- 8) Handle the wires or connectors of the backlight circuit with care. Damaging the wires may cause a short circuit.
- 9) Protect the panel from ESD to avoid damaging the electronic circuit (C-MOS).

SAFETY NOTES

10) During the repair, DO NOT leave the POWER ON or Burn-in period for more than 1 hour while the TV is facing down on a cloth. Refer Figure 1.

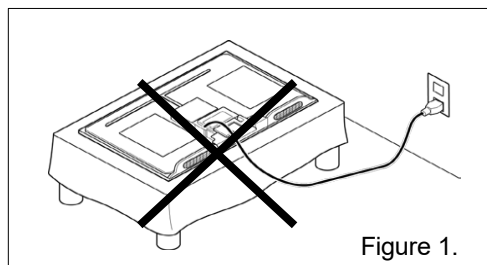

1-3. Caution_for_Board_handling.

The following problems will occur due to handling of the IC mounted on the board

- Solder crack due to substrate handling (stress).
- IC breakdown due to static electricity (ESD).

When repairing the TV at the customer's home or service station or Repair of defect board, please pay attention to the handling of the board.

Substrate that needs attention for handling :

- Main Board (B** Board)
- Backend Board (D** Board)

※ Things to prepare in advance.



※ Caution: ESD wrist-strap to be checked daily.

Use Multi-meter to make sure resistance of ESD wrist-strap is OK.
(R=750K Ohms to 35Mega Ohms)

SAFETY NOTES

ESD cushion / sheet
Please use a bag containing the board or a special seat



1) Caution for Board handling(Stress).Be sure to observe the following contents.

① Hold the board with both hands



② Do not hold/push Heat-Sink



③ Handle with care. Do not swing

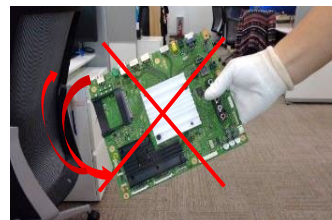

④ Regardless of Good board or Defective board, always put it on ESD cushion / sheet slowly.



⑤ Do not stack up



SAFETY NOTES

- ⑥ Keep vertical position and put in/take out from Box.
Always put into ESD bag then place into Box/Container Box



- ⑦ After take defective board out from TV, put it into ESD bag. Do not place on floor mat/carpet direct and always put it on ESD cushion

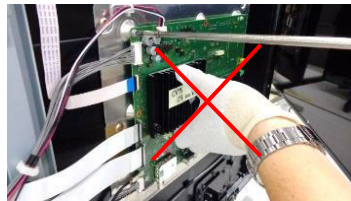
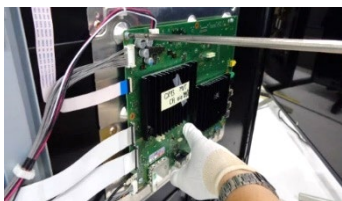

- ① When take off Rear-Cover, do not touch to board



- ② Use ESD wrist-strap



2) Caution for Grounding (ESD) Be sure to observe the following contents

※Installation example of wrist-strap.

Please connect the clip to the metal part of the chassis of the TV with the wristband grounded. Below is a grounding example of each model.

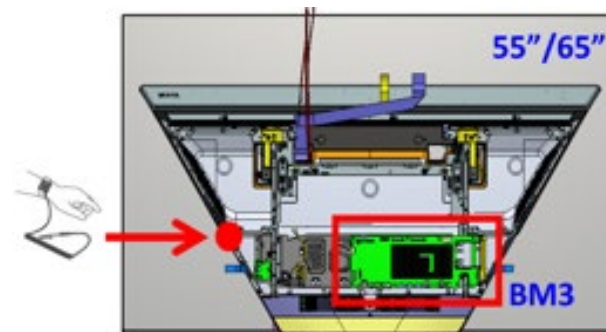

<K*-65Z9F>

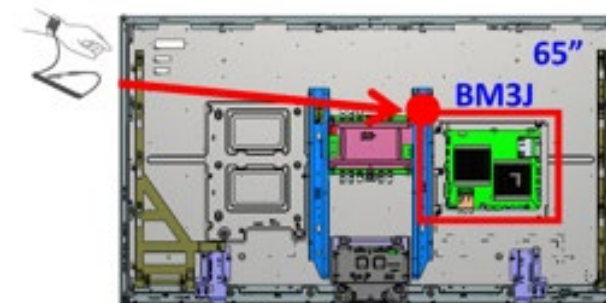

※Caution : ESD wrist-strap to be checked daily.

Use Multi-meter to make sure resistance of ESD wrist-strap is OK.

(R=750K Ohms to 35Mega Ohms)

SAFETY NOTES

- ③ When holding board, do not hit or touch to Plastic part(s)



- ④ After take defective board out from TV, put it into ESD bag.
Do not place on floor mat/carpet direct. And, always put it on ESD cushion



1-4. Caution About the Lithium Battery.

- 1) Danger of explosion if battery is incorrectly replaced.
Replace only with the same or equivalent type.
- 2) Outer case broken battery should not contact to water.

SAFETY NOTES

1-5. Safety Check-Out

After correcting the original service problem, perform the following safety checks before releasing the set to the customer:-

- 1) Check the area of your repair for unsoldered or poorly soldered connections. Check the entire board surface for solder splashes and bridges.
- 2) Check the inter board wiring to ensure that no wires are pinched or contact high-wattage resistors.
- 3) Check all control knobs, shields, covers, ground straps and mounting hardware have been replaced. Be certain you have replaced all the insulators.
- 4) Look for unauthorized replacement parts, particularly transistors that were installed during a previous repair. Point them out to the customer and recommend their replacement.
- 5) Look for parts which show obvious signs of deterioration even though functioning. Point them to the customer and recommend for replacement.
- 6) Check the line cords for cracks and abrasion. Recommend the replacement of any such line cord to the customer.
- 7) Check the antenna terminals, metal trim, metalized knobs, screws and all other exposed metal parts for AC leakage. Check leakage test as described next.
- 8) For safety reasons, repairing the Power board and/or Inverter board is prohibited.

1-6. Leakage Test.

(To protect electric shock when customer touch the terminal.). Leakage current can be measured by V: Voltmeter or oscilloscope (r.m.s or peak reading).

Stabilized power supply instrument and isolated voltage transformer:

Use too much current capacity and isolated voltage transformer does not need to use stabilized power supply equipment.

Specification of RMS voltmeter: Input resistance > 1 Mohm, Input capacitance < 200 pF, Frequency range: 15 Hz – 1MHz . Refer Figure 2. Isolated type voltmeter (FLUKE 8921A etc *1).

*1 Not use FLUKE 8920A that connected to protective earth by diode.

Leakage current of measurement instrument is less than 10µArms when under test equipment AC plug is opened.

Set up the following condition and turn on the set. Applied voltage: Nominal input voltage (Description on Nameplate).

Measure the leakage current between one phase conductor and neutral for terminal A and terminal B.

Read rms value, and then calculate to peak value PEAK VALUE = $\sqrt{2}$ RMS VALUE.

Comply with the following requirement.

Class II equipment (2-pin plug): for each terminal, the worst value of measurement must not exceed AC 350uA peak).

Note: including AC adaptor, AC adaptor/DC operated unit combination.

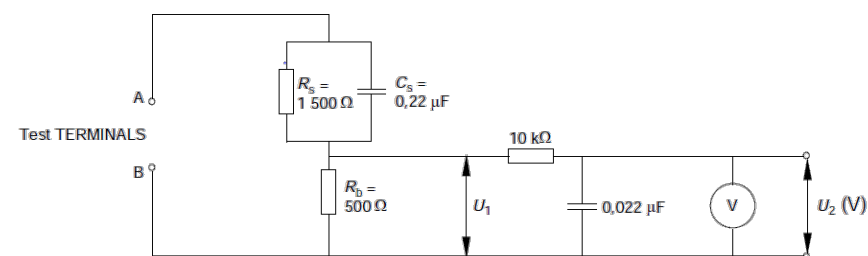

Figure 2 – Measuring network for Leakage Current

IEC 802/98

SAFETY NOTES

1-7. How to Find a Good Earth Ground.

- 1) A cold-water pipe is a guaranteed earth ground; the cover-plate retaining screw on most AC outlet boxes is also at earth ground.
- 2) If the retaining screw is to be used as your earth ground, verify that it is at ground by measuring the resistance between it and a cold-water pipe with an ohmmeter. The reading should be zero ohms.
- 3) If a cold-water pipe is not accessible, connect a 60- to 100-watt trouble-light (not a neon lamp) between the hot side of the receptacle and the retaining screw. Try both slots, if necessary, to locate the hot side on the line; the lamp should light at normal brilliance if the screw is at ground potential (see Figure 3).

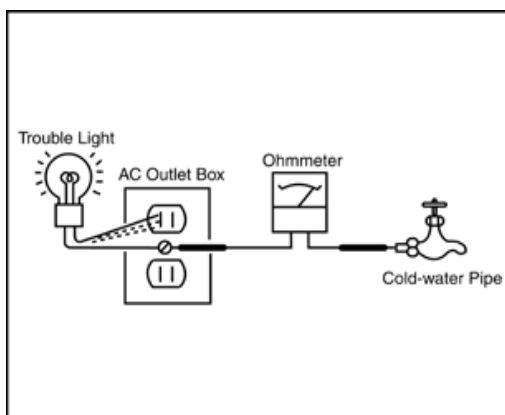

Figure 3. Checking for earth ground.

1-8. Lead Free Information

The circuit boards used in these models have been processed using Lead Free Solder. The boards are identified by the LF logo located close to the board designation.



Figure 4: LF Logo

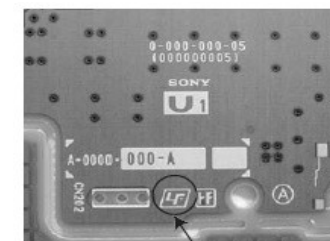

Figure 5: LF logo on circuit board

The servicing of these boards requires special precautions. It is strongly recommended to use Lead Free Solder material in order to guarantee optimal quality of new solder joints.

1-8. FFC Handling Caution

< Application > **WITHDRAWAL OF 41P / 51P FFC CONNECTOR (TYPE1)**

< Connector location > Main board side

< Method > See as follows

< Caution > See as follows

Initial condition

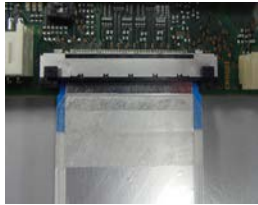

Step 1



Step 2

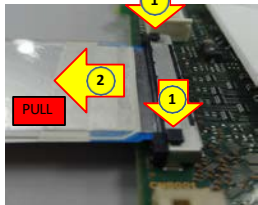

- 1 Press the release lock button downward at same time (highlighted in red).
- 2 Pull FFC in straight direction while pressing both release lock button at the same time.

Note: FFC as in image is only for reference purpose. Actual FFC outlook may vary by each vendor.

< Application > **WITHDRAWAL OF FFC CONNECTOR**

< Connector location > Main board side

< Method > See as follows

< Caution > See as follows

Initial condition



Step 1

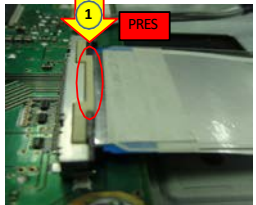

Step 2

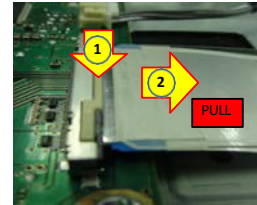

- 1 Press the release lock button downward (highlighted in red).
- 2 Pull FFC in straight direction while pressing release lock button at the same time.

Note: FFC as in image is only for reference purpose. Actual FFC outlook may vary by each vendor.

< Application > **WITHDRAWAL OF 41P / 51P FFC CONNECTOR (TYPE1)**

< Connector location > Main board side

< Method > See as follows

< Caution > See as follows

Initial condition



Step 1

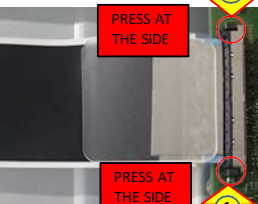

Step 2

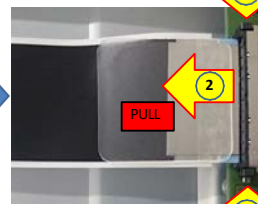

- 1 Press the release lock button sideways at same time (highlighted in red).
- 2 Pull FFC in straight direction while pressing both release lock button at the same time.

Note: FFC as in image is only for reference purpose. Actual FFC outlook may vary by each vendor.

< Application > **WITHDRAWAL OF 51P FFC CONNECTOR**

< Connector location > Panel side

< Method > See as follows

< Caution > See as follows

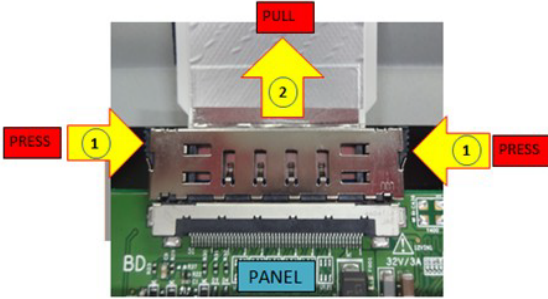

- 1 Please press on both lock release button
- 2 Pull FFC in straight direction while holding both lock release button at the same time

Note: FFC as in image is only for reference purpose. Actual FFC outlook may vary by each vendor.

1-9. Solder-less Tuner Replacement

Solder-less tuner replacement procedure

Mounting Method

- ① The insertion & extraction angle of the module is permitted to specified degree for connector

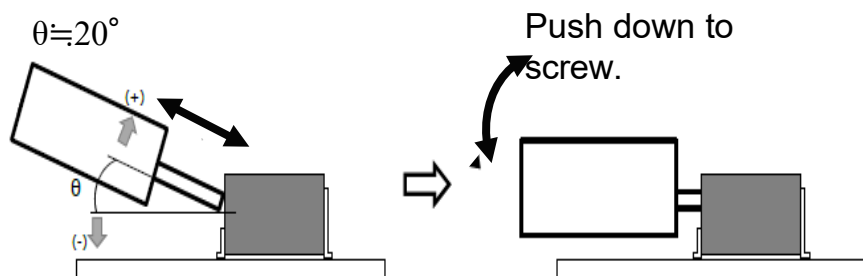

- ② Please insert or extract the module straightly toward the connector. Do NOT insert or extract the module with an angle.

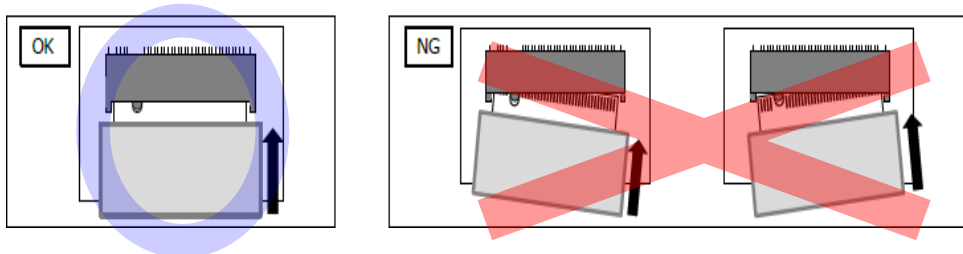

Service manual operation (agreed by service member):
Not using insertion jig. Due quantity not many as production.
SC can control by:
 1) Issue service manual for WW ASC.
 2) Give training/lecture how to assemble tuner. Will be handle by SOEM service PIC.

- For removing Tuner Module, In the case of small type Tuner module. After un screwed, Automatically the Module will float to correct degree. So please extract it with keeping this degree.

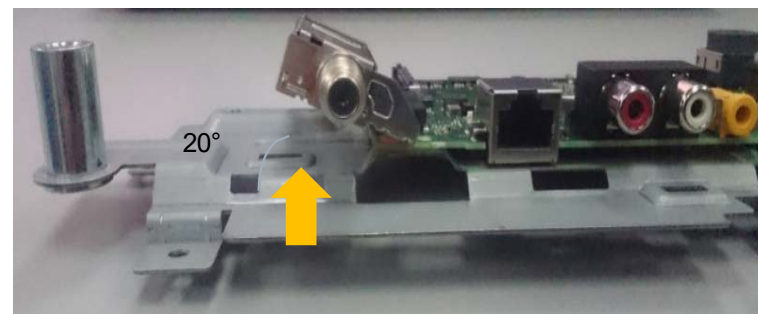

- Please confirms whether no dust and no bend on terminal of connector(CN2800) and card-edge connector
- Attachment order of screw.
 1. Side of antenna terminal (W/BFM board).
 2. Rear side of Tuner module.

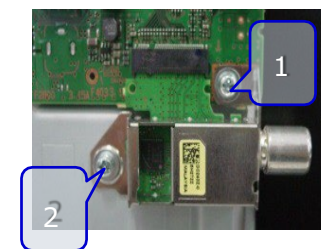

SECTION 2

SELF DIAGNOSTIC FUNCTION

The units in this manual contain a self-diagnostic function. If an error occurs, the Smart Core Red LED will automatically begin to flash.

The number of times the LED flashes translates to a probable source of the problem.

A definition of the Smart Core Red LED flash indicators is listed in the instruction manual for the user's knowledge and reference.

If an error symptom cannot be reproduced, the remote commander can be used to review the failure occurrence data stored in memory to reveal past problems and how often these problems occur.

DIAGNOSTIC TEST INDICATORS

When an error occurs, the Smart Core Red LED will flash a set number of times to indicate the possible cause of the problem.

If there is more than one error, the LED will identify the first of the problem areas.

Result for all of the following diagnostic items are displayed on screen.

If the screen displays a "0", no error has occurred .

Self Diag. Quick Reference (LED blinking)

Smart Core RED LED blinking count	Detection Items
2x	< B/G/A/LD > Main 12V over voltage [MAIN_POWER]
3x	 Main 5.0V failure [DC_ALERT] <B/S> Audio amp. protection [AUD_ERR]
5x	<P/T/G/B/LD> <i>Panel ID EEPROM I2C No ACK (Also panel power failure is a suspect) [P_ID_ERR]</i>
6x	< G/ P/ B/ LD> Backlight failure [BACKLIGHT]
7x	< B> Over temperature protection [TEMP_ERR] Temp. sensor I2C No ACK [TEMP_ERR]
8x	< B> 4KPQ WDT [4KPQ Error] <i>BOOTUP_NOTE low</i>

Blue italic: detect at startup sequence only.
<G>: Power supply board, : Main board, <T>: T-con board,
<LD>: LD board (if AC adapter model, it would power supply for Set), <P>: Panel module, <S>: Speaker, <A>: Power Adapter,
<Tu>: Tuner board, <K> : Audio board

Self Diag. Quick Reference (Not LED blinking [Record Only])

Record Only Item	Detection Items
TU_DEMOD	None
TCON_ERR	<B/T> <i>T-CON device I2C communication failure</i>
FRCTC_I2C	 <i>FRC device is not finished Initial sequence</i> FRC device I2C communication failure
AUD_ERR_I2C	 Audio amp I2C communication failure
4KPQ_ERR_I2C	 4KPQ device I2C communication failure

Blue italic: detect at startup sequence only.

<G>: Power supply board, : Main board, <T>: T-con board, <TE>: Temp Sensor board,

<LD>: LD board (if AC adapter model, it would power supply for Set), <P>: Panel module, <S>: Speaker, <A>: Power Adapter,

<Tu>: Tuner board, <K>: Audio Board

Retry Limitation by Remote/Power Key

Smart Core Red LED blinking count	Error Name	Retry Permission Times *1	Note
2x	MAIN_POWER	STDWN_RTRY_LIMIT_MAINPOWER = 1	
3x	DC_ALERT (5V)	STDWN_RTRY_LIMIT = 2	
	AUD_ERR	STDWN_RTRY_LIMIT = 2	
4x	LD_ERR	STDWN_RTRY_LIMIT = 2	
	BCM_ERR	STDWN_RTRY_LIMIT = 2	
5x	P_ID_ERR	STDWN_RTRY_LIMIT = 2	
6x	BACKLIGHT	STDWN_RTRY_LIMIT = 2	
7x	TEMP_ERR	STDWN_RTRY_LIMIT = 2	
8x	4KBE_ERR	STDWN_RTRY_LIMIT = 2	
	4KPQ_ERR	STDWN_RTRY_LIMIT = 2	

> Number of off/on action for MAIN_POWER shutdown is recorded to $STDWN_OFFON_CNT_MAIN_POWER^{*2}$

Number of off/on action during the error shutdown is recorded to $STDWN_OFFON_CNT^{*2}$

* 1) If $STDWN_OFFON_CNT \leq STDWN_RTRY_LIMIT$, and $STDWN_OFFON_CNT_MAIN_POWER \leq STDWN_RTRY_LIMIT_MAINPOWER$, you can turn the set on by a remote/power key. At this time, if the error occurs again, the $STDWN_OFFON_CNT$ is incremented by 1.

*2) When the main micro operates normally for $STDWN_OFFON_CLR = 60$ minutes, $STDWN_OFFON_CNT$ and $STDWN_OFFON_CNT_MAIN_POWER$ are cleared.

SECTION 3 TROUBLESHOOTING

Triage Chart

Before you make the service call...

1. Confirm the symptom from the customer.
2. Select that symptom from the chart.
3. Bring all the boards and cables listed for that symptom.
4. Follow the troubleshooting charts in the technical guides to isolate the board.
5. Chart Colour Code

RED DOT: Most likely defective part

BLUE TRIANGLE: Secondary possible defective part

BLACK TEXT: Board that may correct the symptom

Reference	Symptoms - Shutdown. Power LED blinking red diagnostics sequences							Symptoms - no shutdown Error log record only					No Power	Video - missing or distorted				Remote	Network	Audio	Smart Core	Bluetooth (BT)
	2	3	4	5	6	7	8	TU_DEMOD	TCON_ERR	FRCTC_I2C	AUD_ERR_I2C	4KPQ_ERR_I2C	No White Power LED & does not respond to remote (Dead Set)	Stationary colored lines or dots	No video One of inputs	NO RF input	No video all Inputs	No Remote Operation	Cannot connect to Wireless Network	No Audio	Smart Core no LED (Set is still alive)	Bluetooth / One Step Remote (OSR) can't connect
Main Board	▲	●		▲	▲	●	●	▲	▲	●	●	●	▲	▲	●	●	●	▲	▲	●	▲	▲
Power Board	●	▲		▲	●								●							▲		
Receiver Board													▲					●		●		
LD* Board					●																	
Speaker		▲																		●		
Tuner board								●							▲	●						
Wi-fi & BT Module																		●				●
V By One FFC				▲					▲					▲			▲					
T-con				●					●					▲			▲					
LCD Panel				▲	●	▲								●			▲					
Problem	Power	Power	LD	Panel (Communication)	Panel (Backlight)	TEMP	4KPQ															
		Audio	BCM																			

1.0 NO POWER-PSU

Overall Flow chart NO POWER G-Board

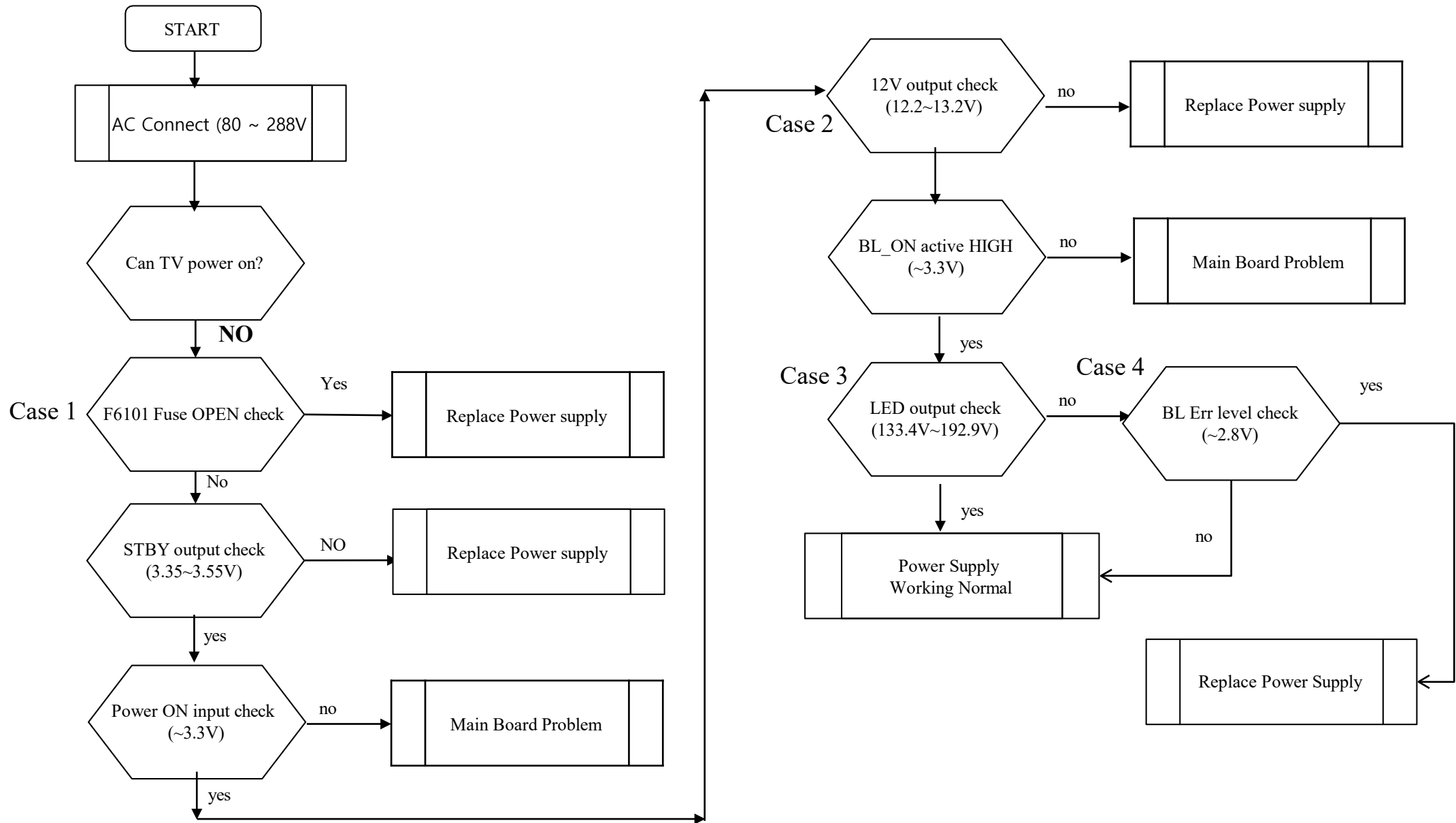

1.2 No Power – μ-Com Failure

P-on u-com control signal path summary

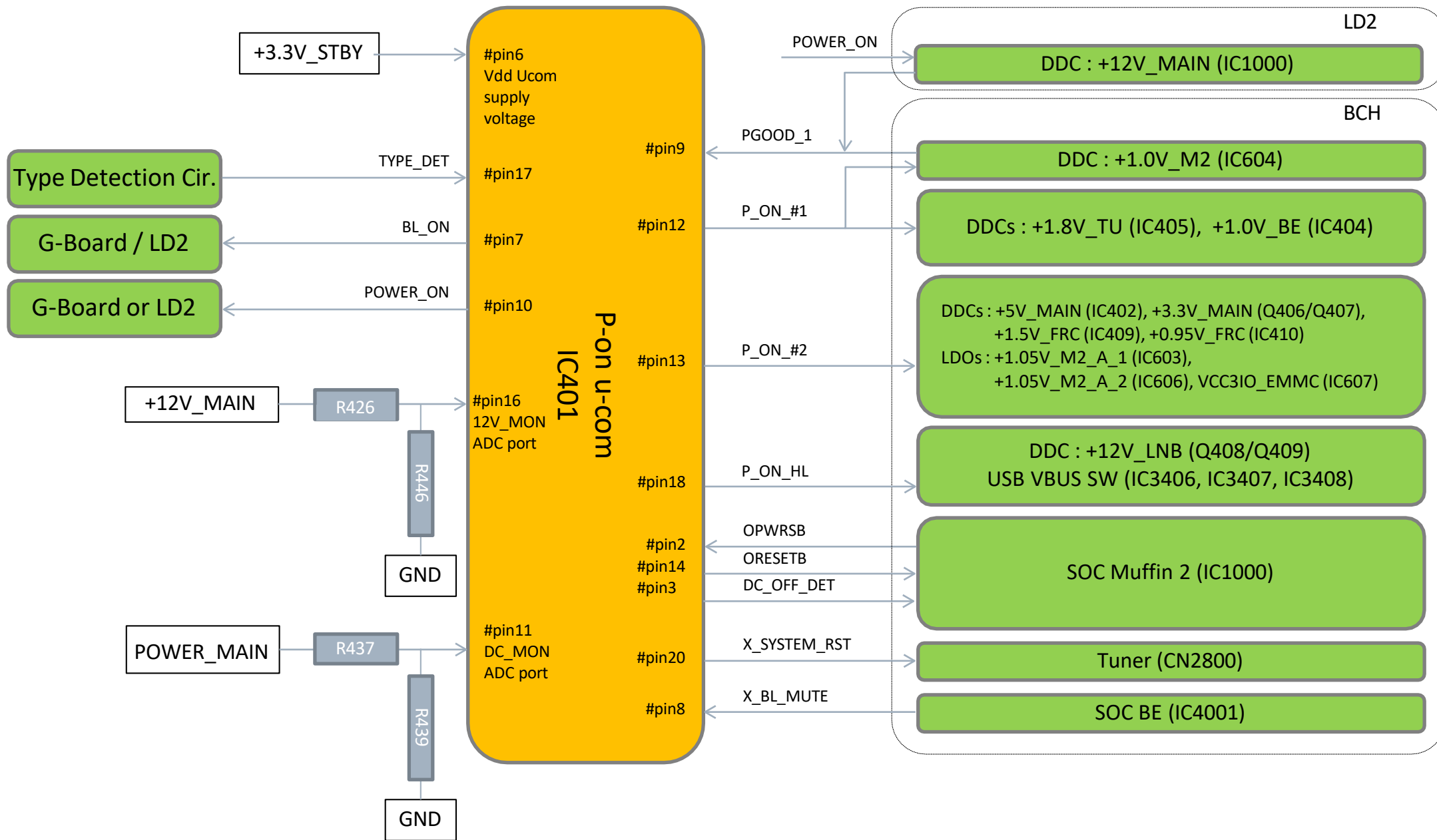

1.2 No Power – μ-Com Failure

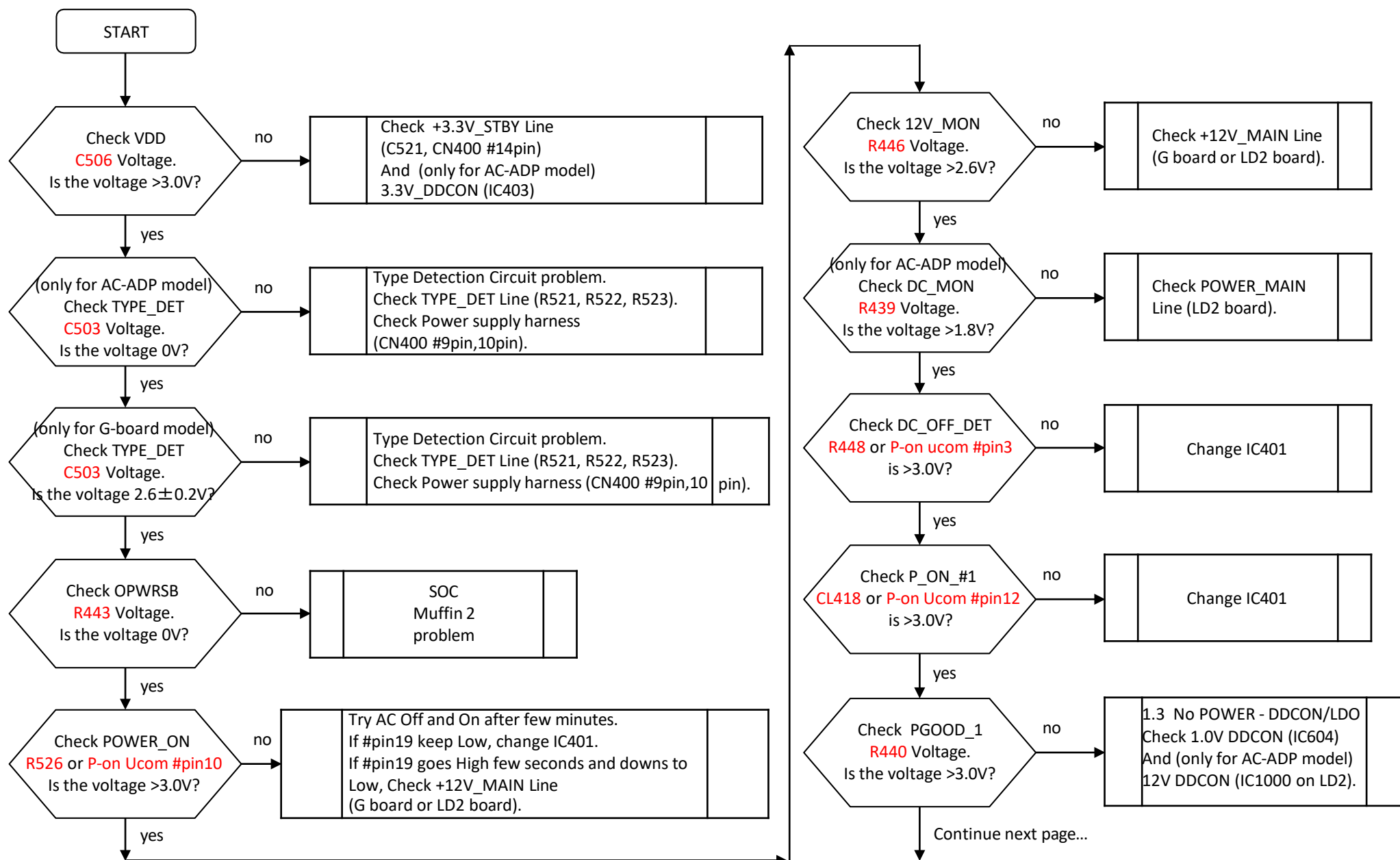

1.2 No Power – μ -Com Failure

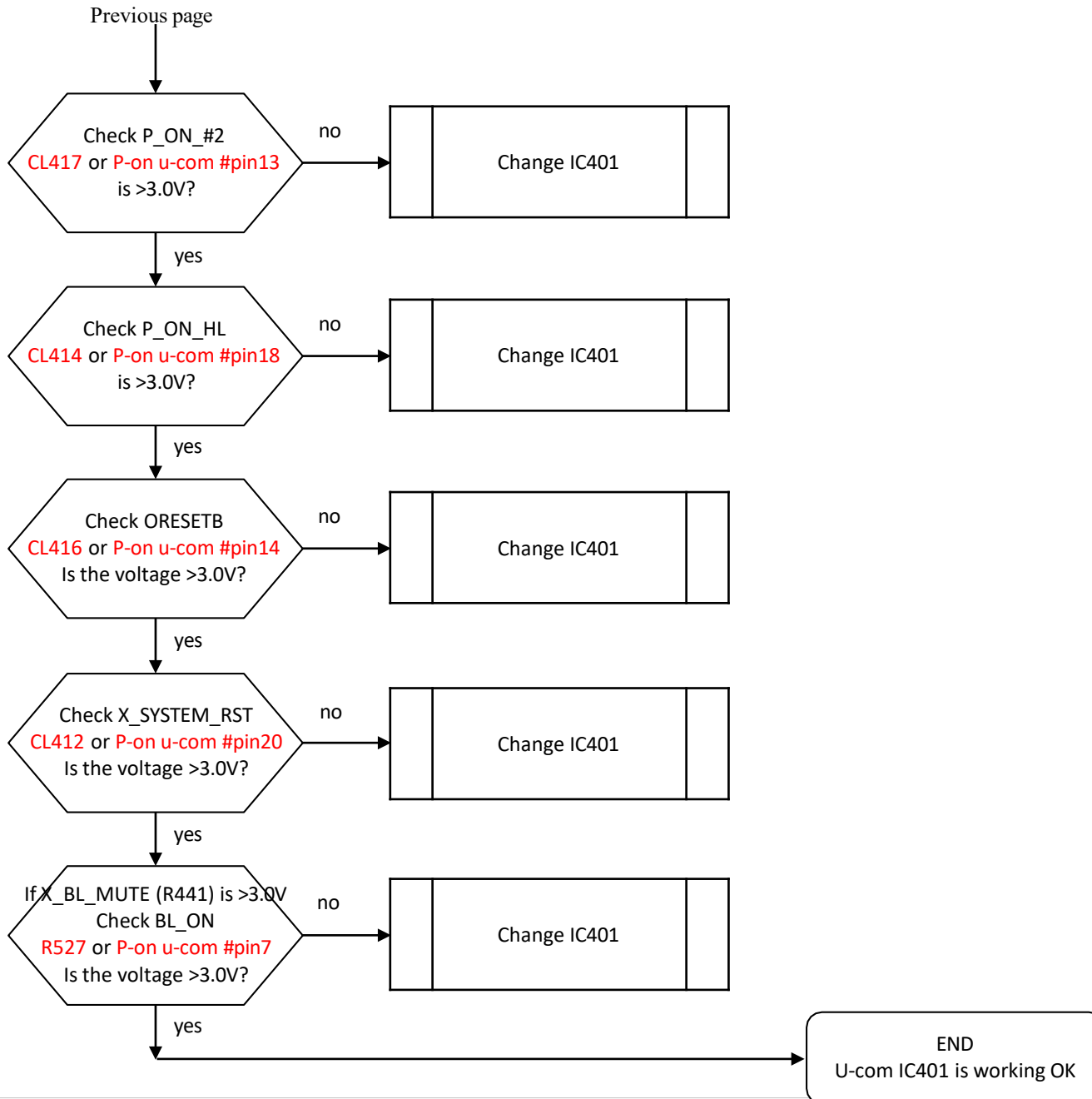

1.3 No Power – DDCON/LDO

Check item summary

Board	IC Ref	Voltage supply	Output ref.	Enable pin	Enable source	Fuse	Vcc ref.
LD2		+12V_MAIN (AC-ADP only)			P-on u-com IC401 #pin10		
BCH	IC402	+5.0V_VBUS/+5V_MAIN	C430	R455	P-on u-com IC401 #pin13	F400	C423
BCH	IC403	+3.3V_STBY (AC-ADP only) /+3.3V_MAIN	C445	R467	R464 (POWER_MAIN)	F401	C436
BCH	Q407	+3.3V_MAIN		Q406	P-on u-com IC401 #pin13		C445
BCH	IC405	+1.8V_TU/+1.8V_BE	C463	IC405 #PIN5	P-on u-com IC401 #pin12	F403	C461
BCH	IC404	+1.0V_BE	C456	R480(No M't)	P-on u-com IC401 #pin12	F402	C454
BCH	IC409	+1.5V_FRC	C478	IC409 #PIN5	P-on u-com IC401 #pin13	F404	C476
BCH	IC410	+0.95V_FRC	C493	R506	P-on u-com IC401 #pin13	F405	C485
BCH	IC601	+1.5V_DDR	C609	C605	R603 (3.3V or 5V)	-	C602
BCH	IC602	+1.05V_M2_STBY	C611	IC602 #PIN3	C610 (+3.3V_STBY)	-	C610
BCH	IC603	+1.05V_M2_A_1	C613	IC603 #PIN3	P-on u-com IC401 #pin13	-	C612
BCH	IC604	+1.0V_M2	C625	R623	P-on u-com IC401 #pin12	F600	C618
BCH	IC605	+1.05V_M2_ST_ET	C631	IC605 #PIN3	M2 IC1000 #AP34	-	C630
BCH	IC606	+1.05V_M2_A_2	C633	IC606 #PIN3	P-on u-com IC401 #pin13	-	C632
BCH	IC607	VCC3IO_EMMC (1.8V)	C635	IC607 #PIN3	P-on u-com IC401 #pin13	-	C634

1.3 No Power – DDCON/LDO

AC-ADP Model

DDCONs check on LD2*

IC Ref	Voltage supply
IC1000	+12V_MAIN

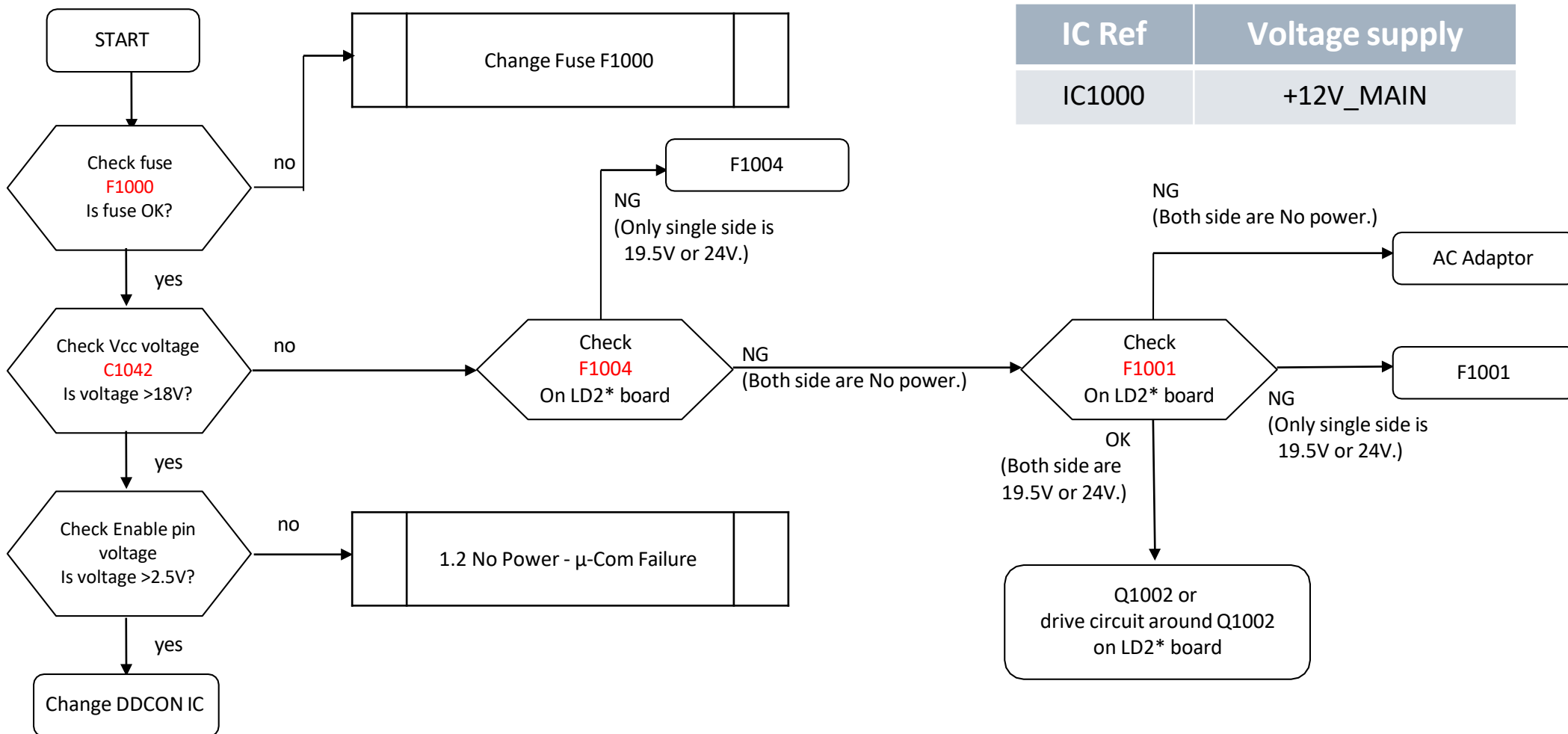

1.3 No Power – DDCON/LDO

DDCON check

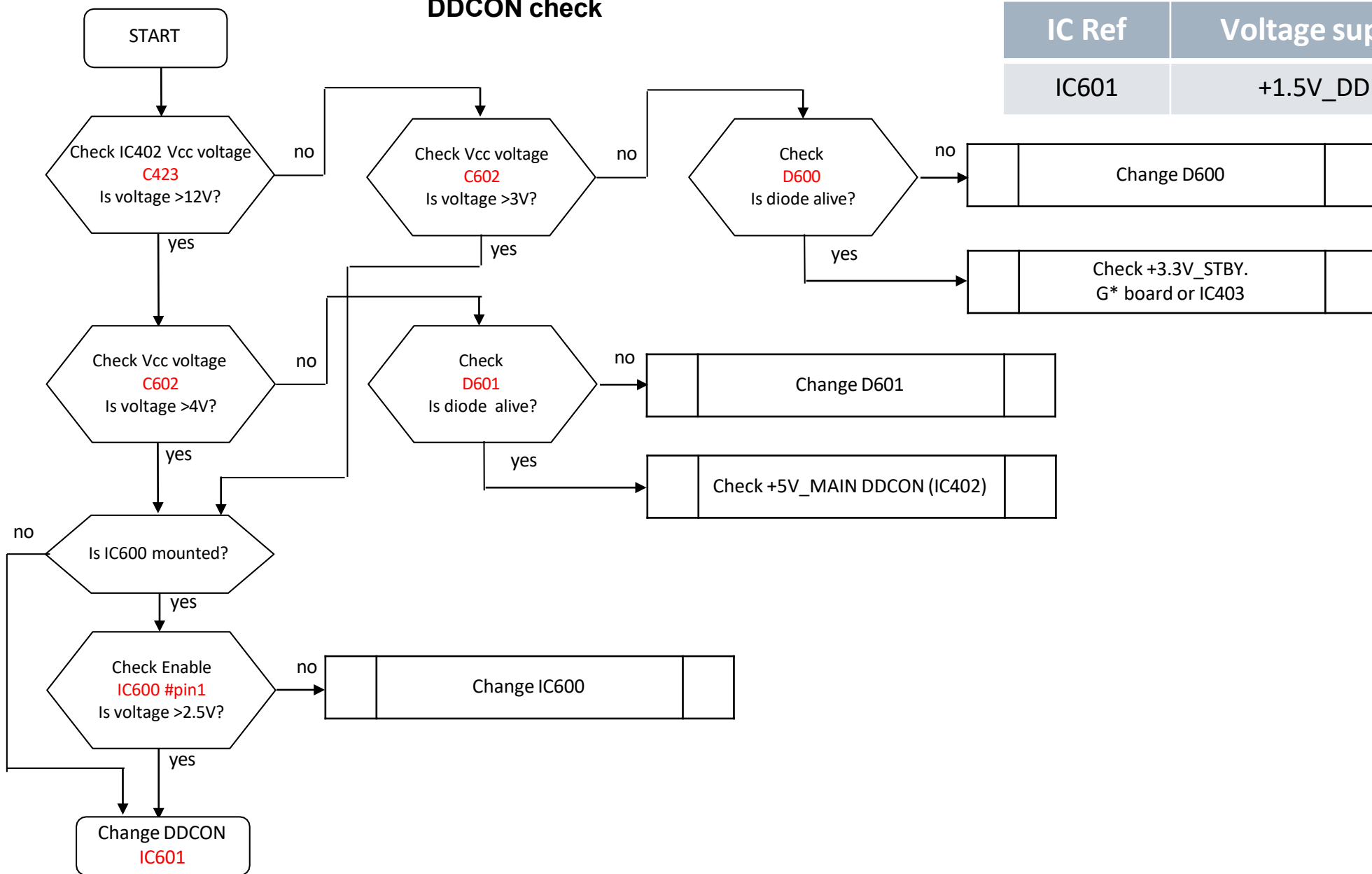

IC Ref	Voltage supply
IC601	+1.5V_DDR

1.3 No Power – DDCON/LDO

DDCONs check

Please refer page 1.3 No Power – DDCON/LDO
Check item summary for Ref number.

IC Ref	Voltage supply
IC402	+5.0V_VBUS/+5V_MAIN
IC403	+3.3V_STBY (AC-ADP only) /+3.3V_MAIN
IC405	+1.8V_TU/+1.8V_BE
IC404	+1.0V_BE
IC409	+1.5V_FRC
IC410	+0.95V_FRC
IC604	+1.0V_M2

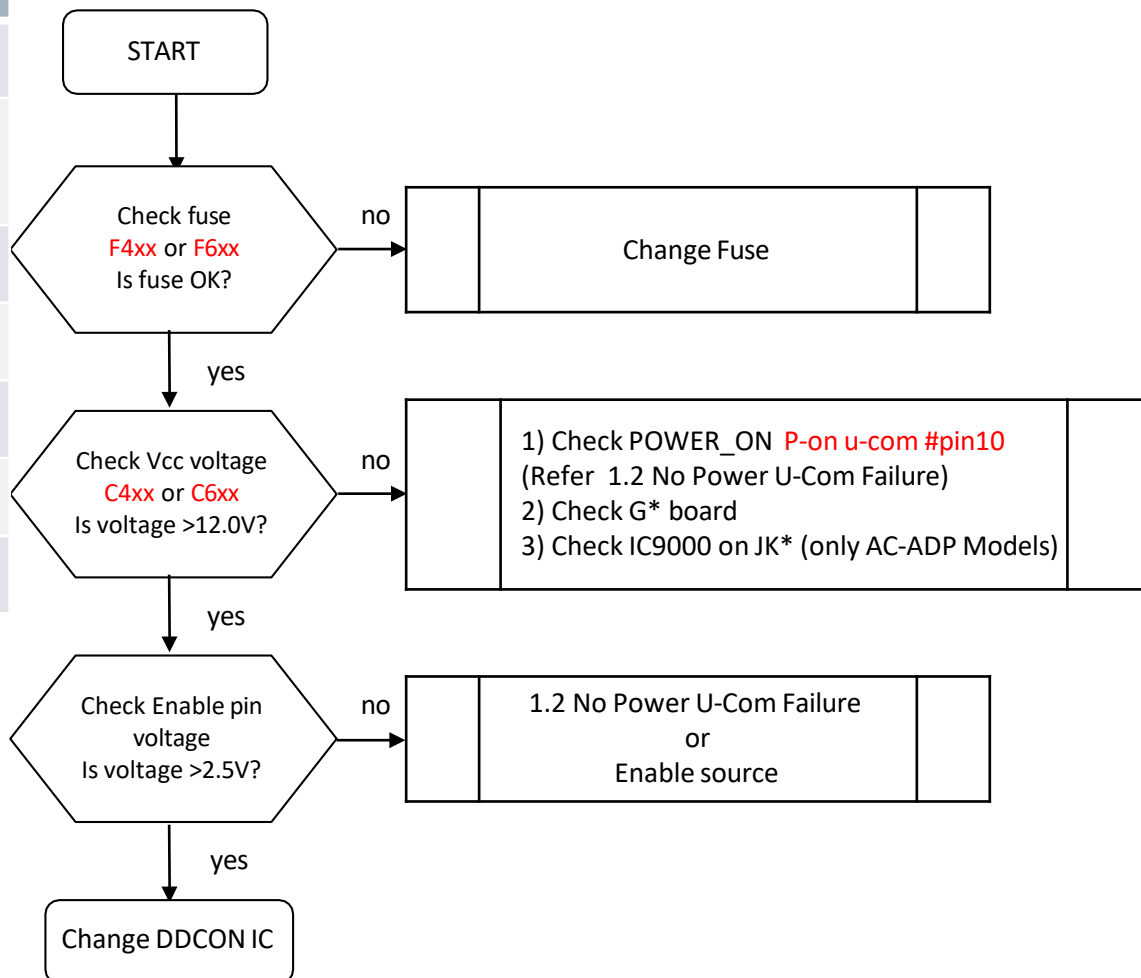

1.3 No Power – DDCON/LDO

Please refer page 1.3 No Power – DDCON/LDO
Check item summary for Ref number.

IC Ref	Voltage supply
IC602	+1.05V_M2_STBY
IC603	+1.05V_M2_A_1
IC605	+1.05V_M2_ST_ET
IC606	+1.05V_M2_A_2
IC607	VCC3IO_EMMC (1.8V)

LDOs check

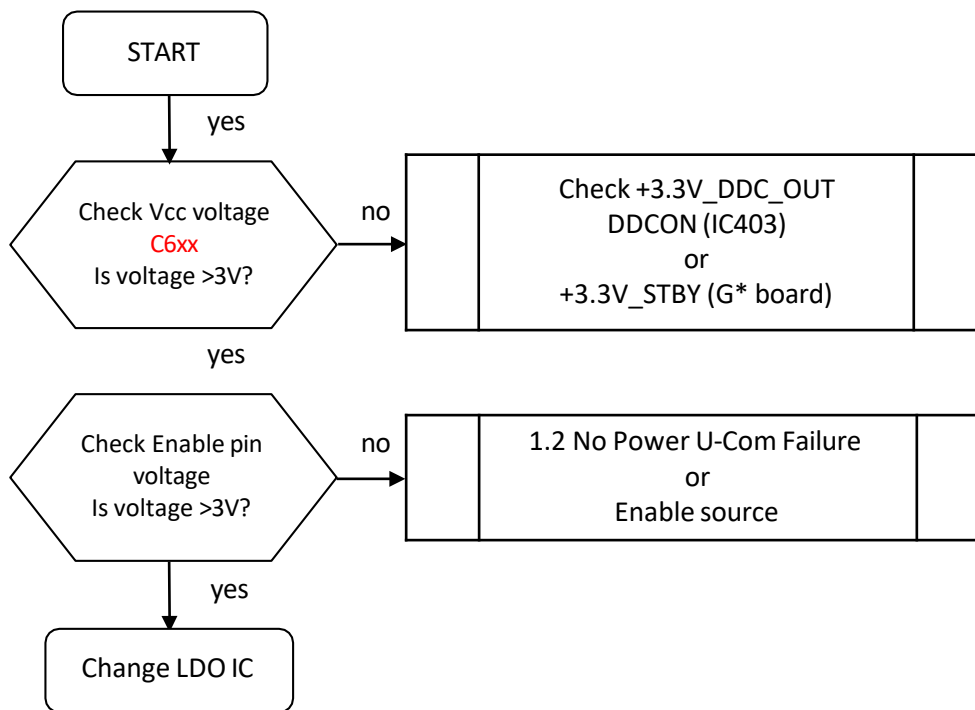

2.0 LED Blinking: 2x (Main Power Error)

BCH (AC adapter model)

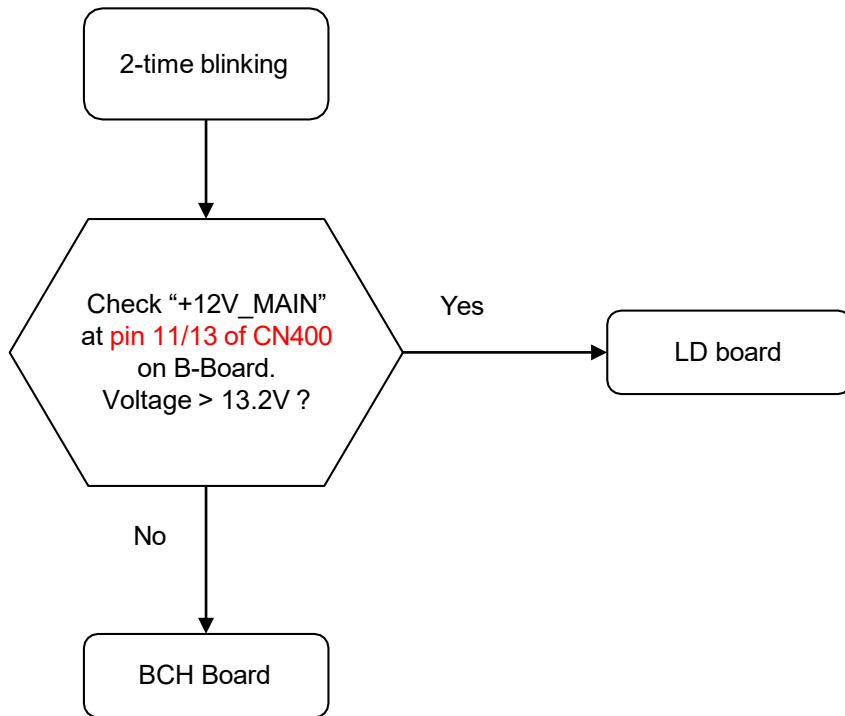

BCH (G-Board model)

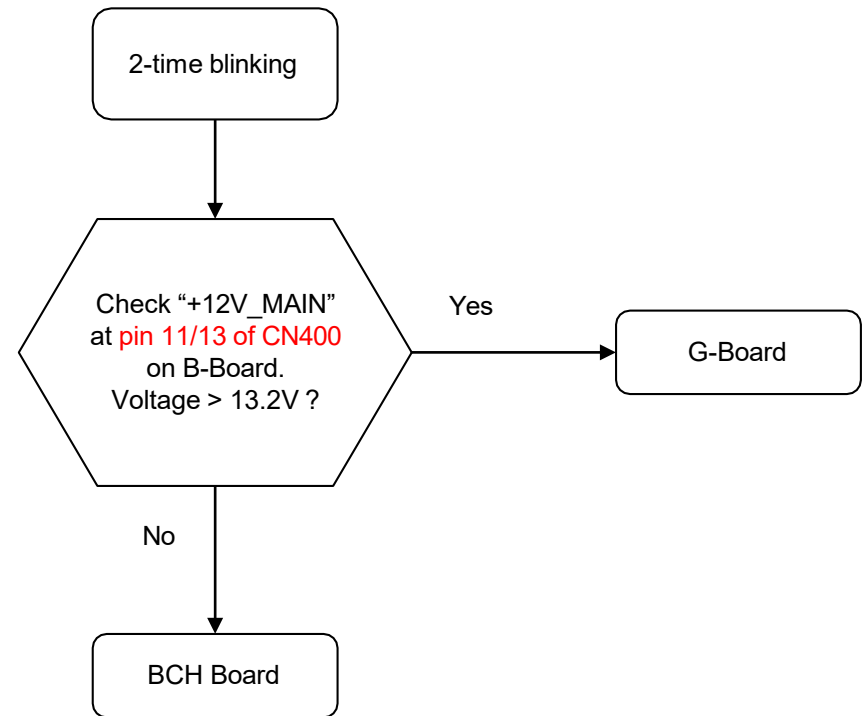

2.0 LED Blinking: 2x (Main Power Error)

Check Point for BCH

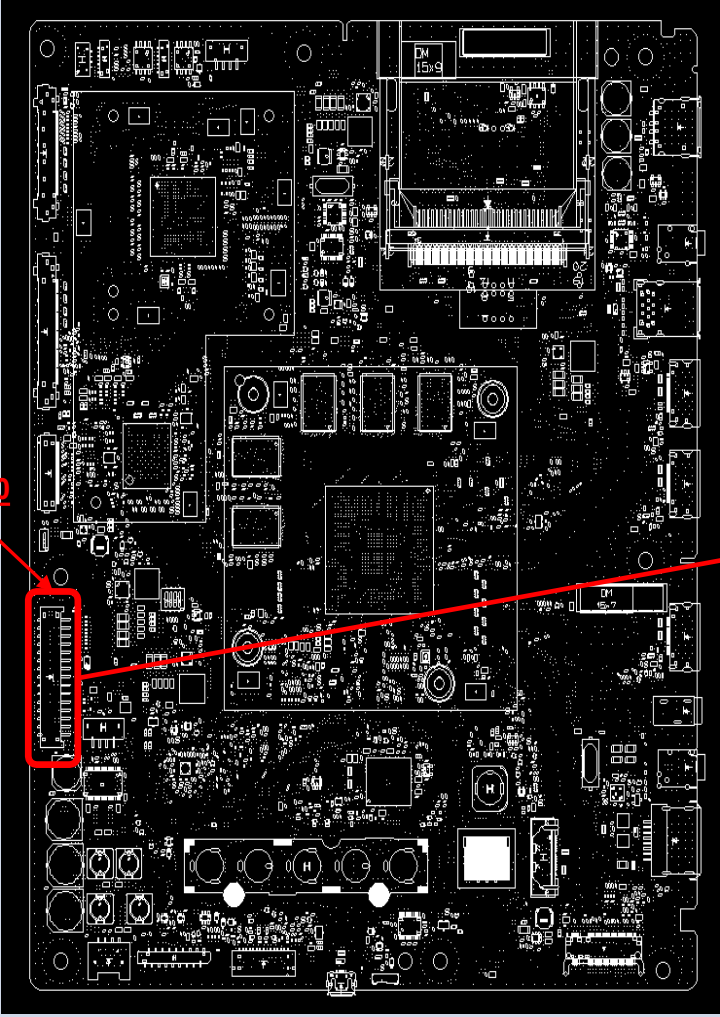
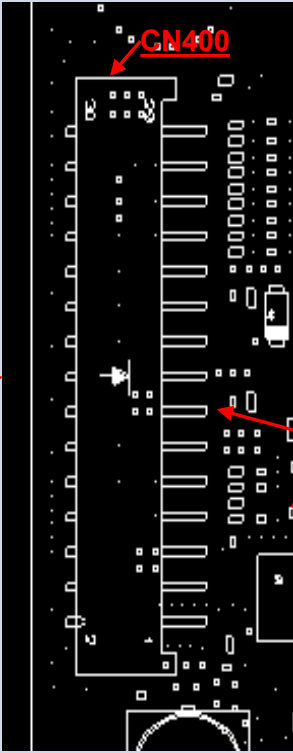
BCH (A side)	Detail
 <p>A top-down view of a black PCB. A red box highlights a connector on the left side, labeled "CN400" with a red arrow pointing to it.</p>	 <p>A detailed view of the CN400 connector. A red arrow points to the top of the connector, labeled "CN400". Another red arrow points to a specific pin, labeled "pin 11/13 '+12V_MAIN'".</p>

2.1 LED Blinking: 3x (DC Alert)

Details of 3x LED blinking

	Error Item	Number of STBY LED flashing	Description
Trinity3	DC_ALERT	3	Main board 5V power rail monitoring
	AUD_ERR	3	Audio amp error detection

Trinity3 Board: BCH

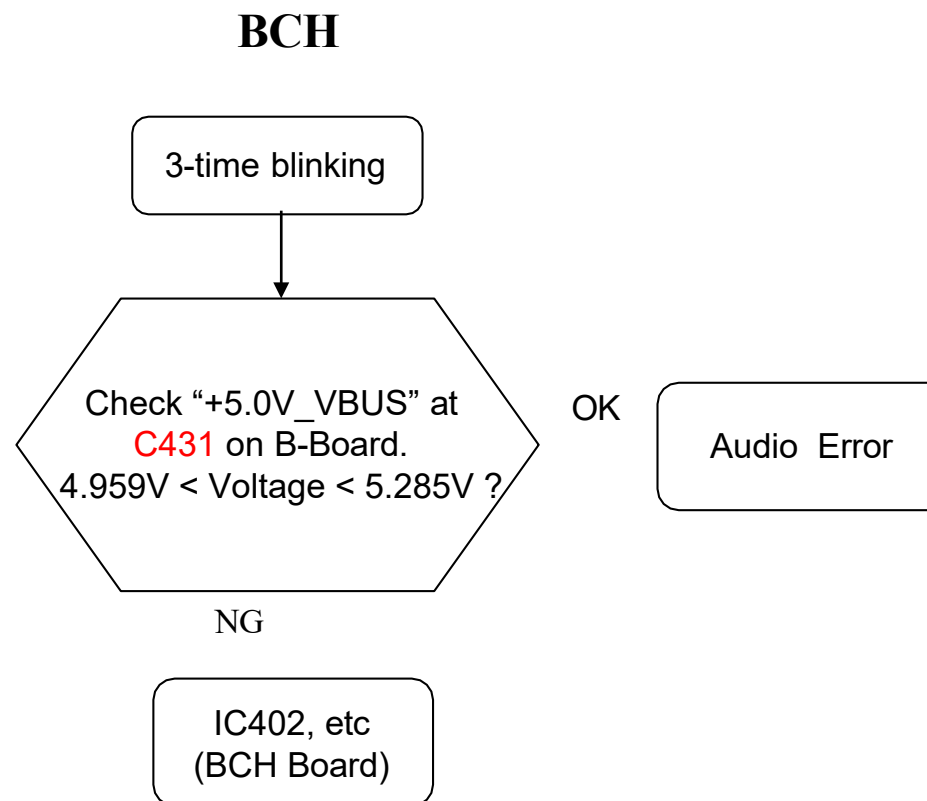

2.1 LED Blinking: 3x (DC Alert)

Check Point for BCH

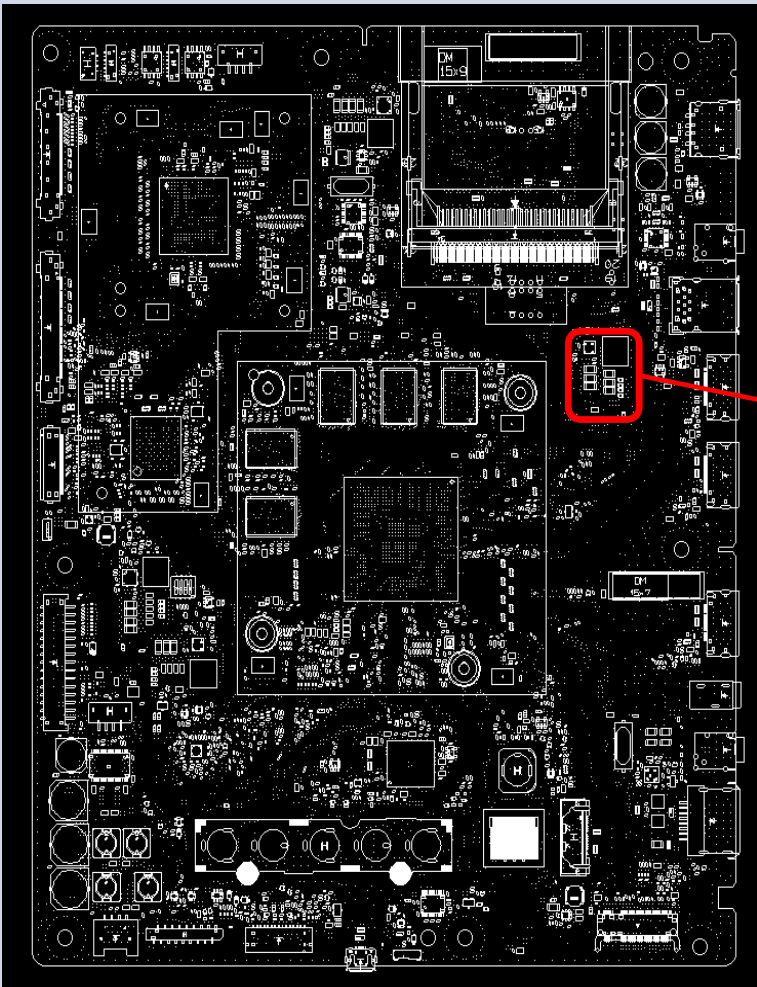
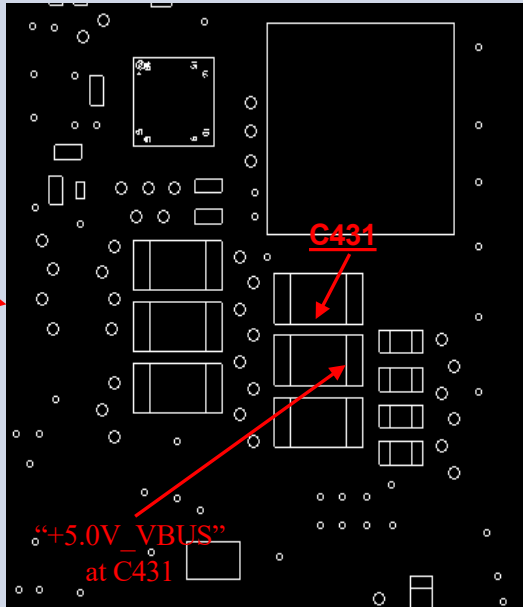
BCH (A side)	Detail
 A high-contrast, black and white image of a printed circuit board (PCB) showing various components. A red rectangular box highlights a specific area on the right side of the board, containing several small components. A red arrow points from this box to the detail view on the right.	 A detailed view of the component area highlighted in the main image. It shows a capacitor labeled "C431" in red text. Below it, another red arrow points to a component labeled "+5.0V_VBUS" at C431. The background is black with white outlines of components and traces.

2.2 LED Blinking: 3x (Audio Error)

Detail of 3x LED Blinking

Error Item	Number of STBY LED flashing	Description
DC_ALERT	3	Main board 5V power rail monitoring
AUD_ERR	3	Audio amp error detection

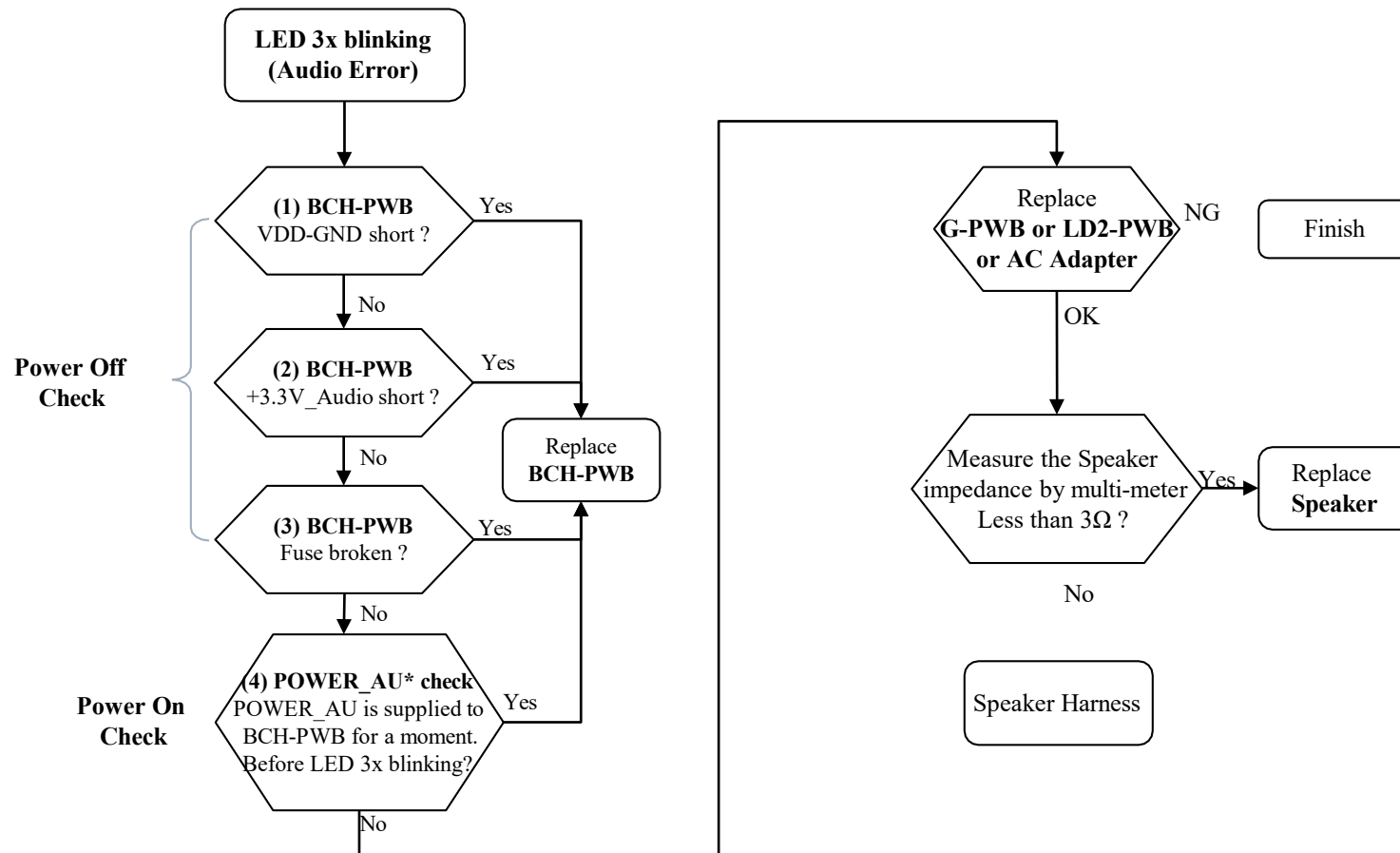

*POWER_AU is same as VDD

2.2 LED Blinking: 3x (Audio Error)

BCH-PWB

(1) VDD-GND short check

Measure impedance between VDD and GND at capacitor C3244.

impedance is $<100\Omega$ → NG

(3) Fuse open check

Measure impedance of fuse F3200 5A (12.5V or 19.5V)

fuse open → NG

(2) +3.3V_Audio short check

Measure impedance between +3.3V and GND at R3242(1).

impedance is $<100\Omega$ → NG

(4) POWER_AU check

Measure voltage at capacitor C3244.

voltage is $<$ → NG

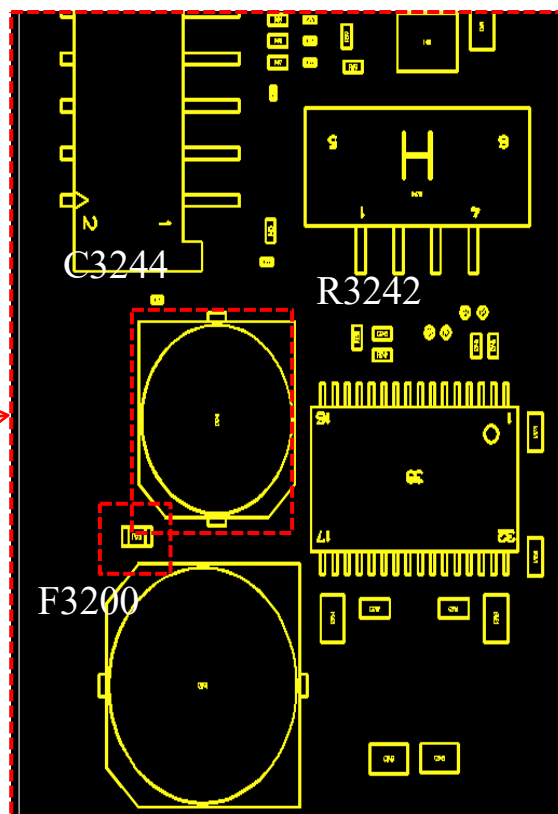
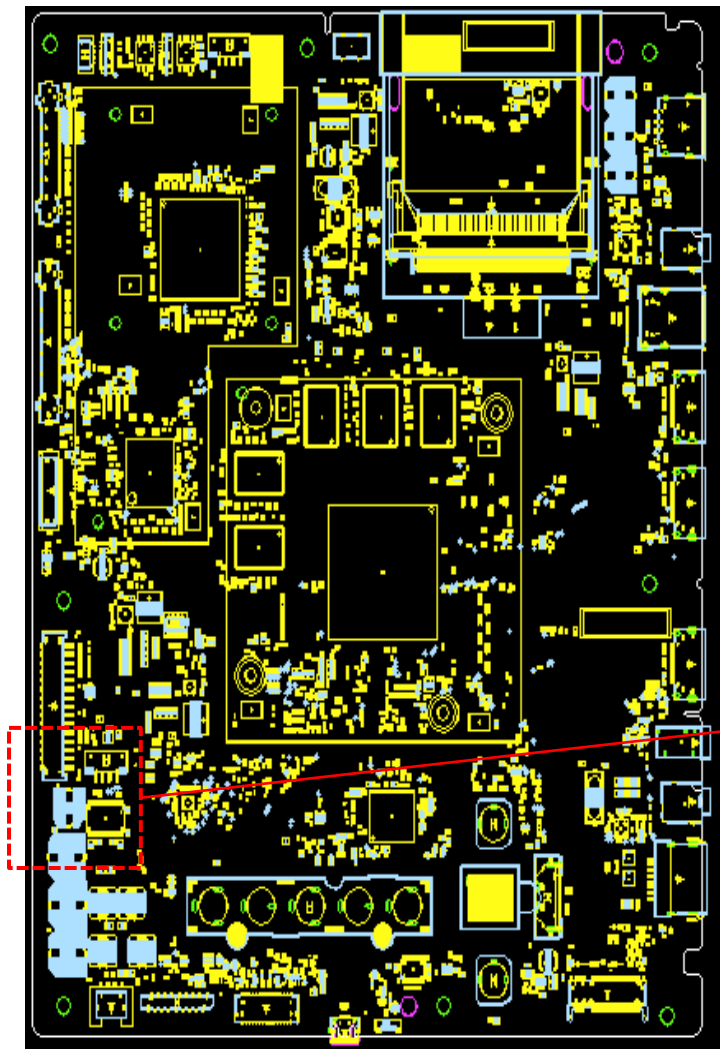

2.5 LED Blinking: 5x (Panel ID Read Error)

LED Blinking: 5x (Panel ID Read Error)

BCH

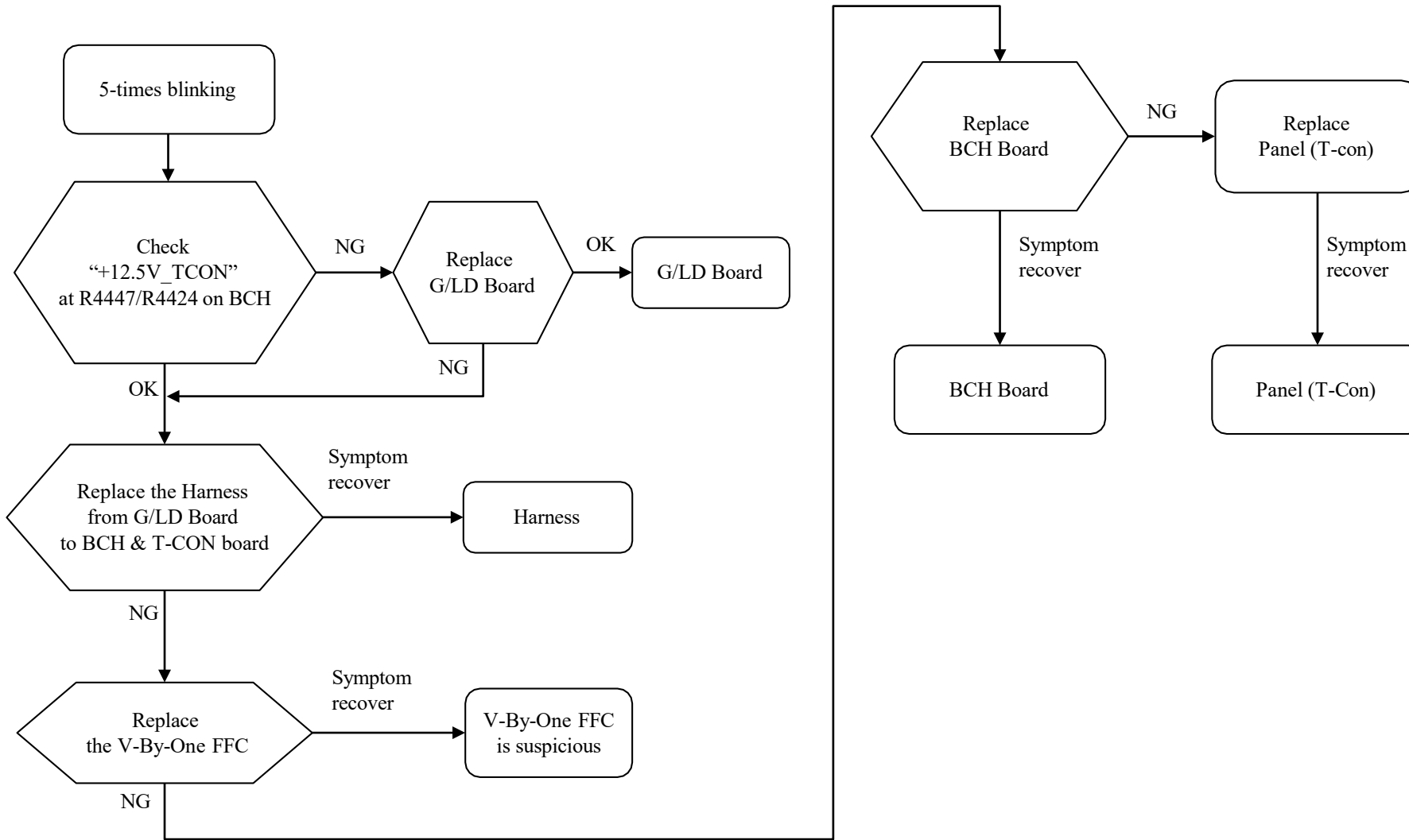

G/LD Board: G board or LD board

2.5 LED Blinking: 5x (Panel ID Read Error)

Check point for BCH

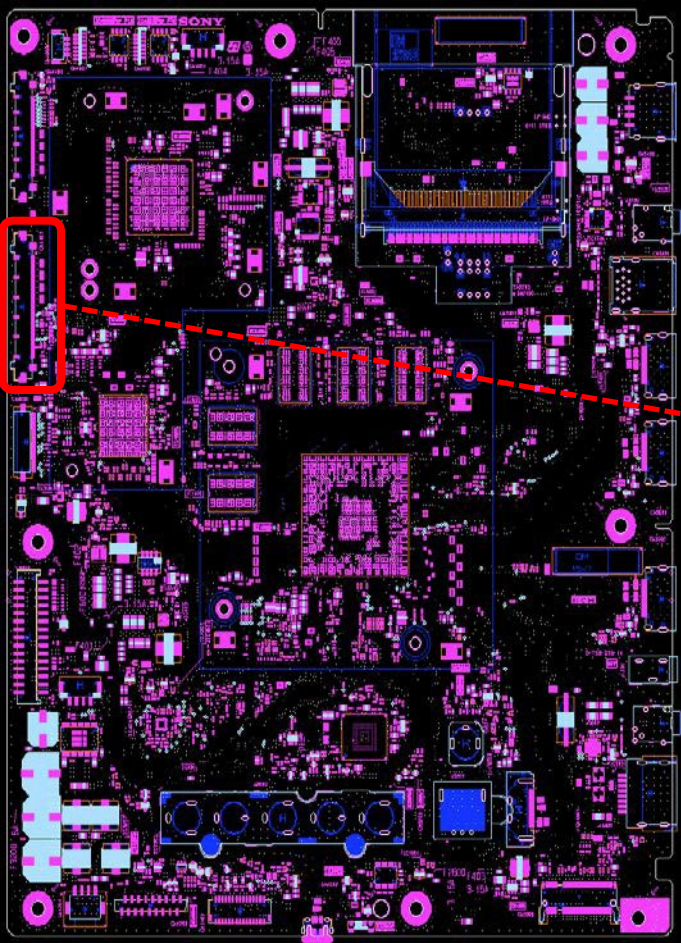
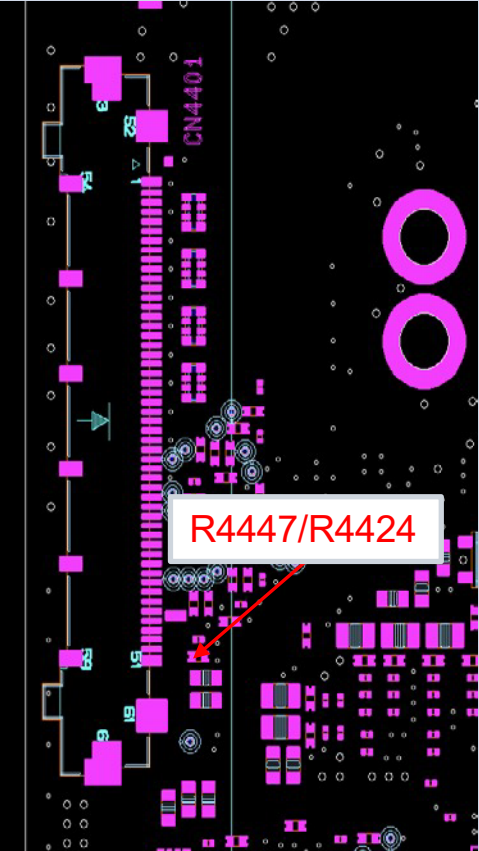
Name	Board PWB (A side)	Detail
<p>BCH</p>		

2.6 LED Blinking: 6x (Panel Backlight Error)

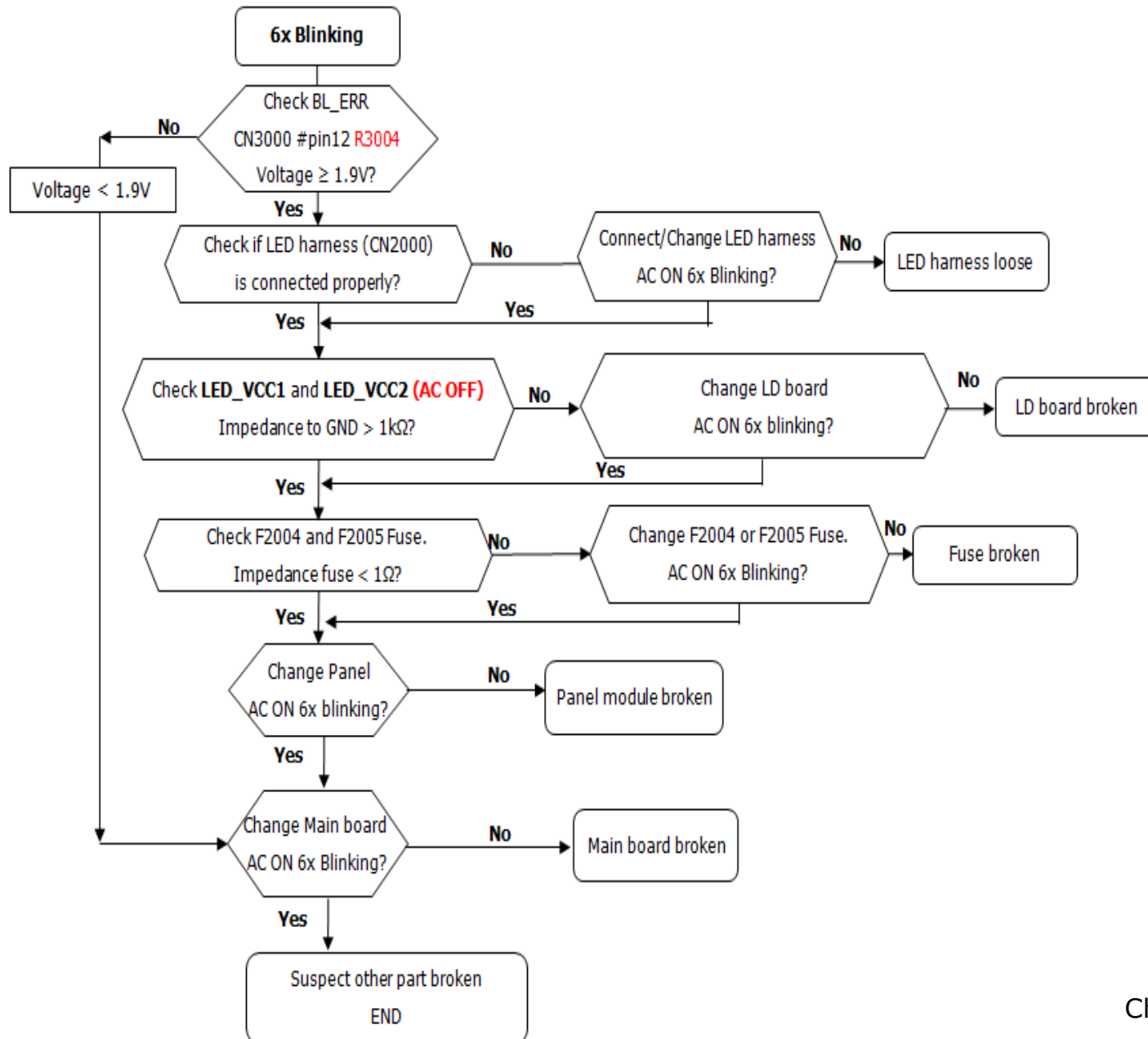

Check point on PWB refer next slide

2.6 LED Blinking: 6x (Panel Backlight Error)

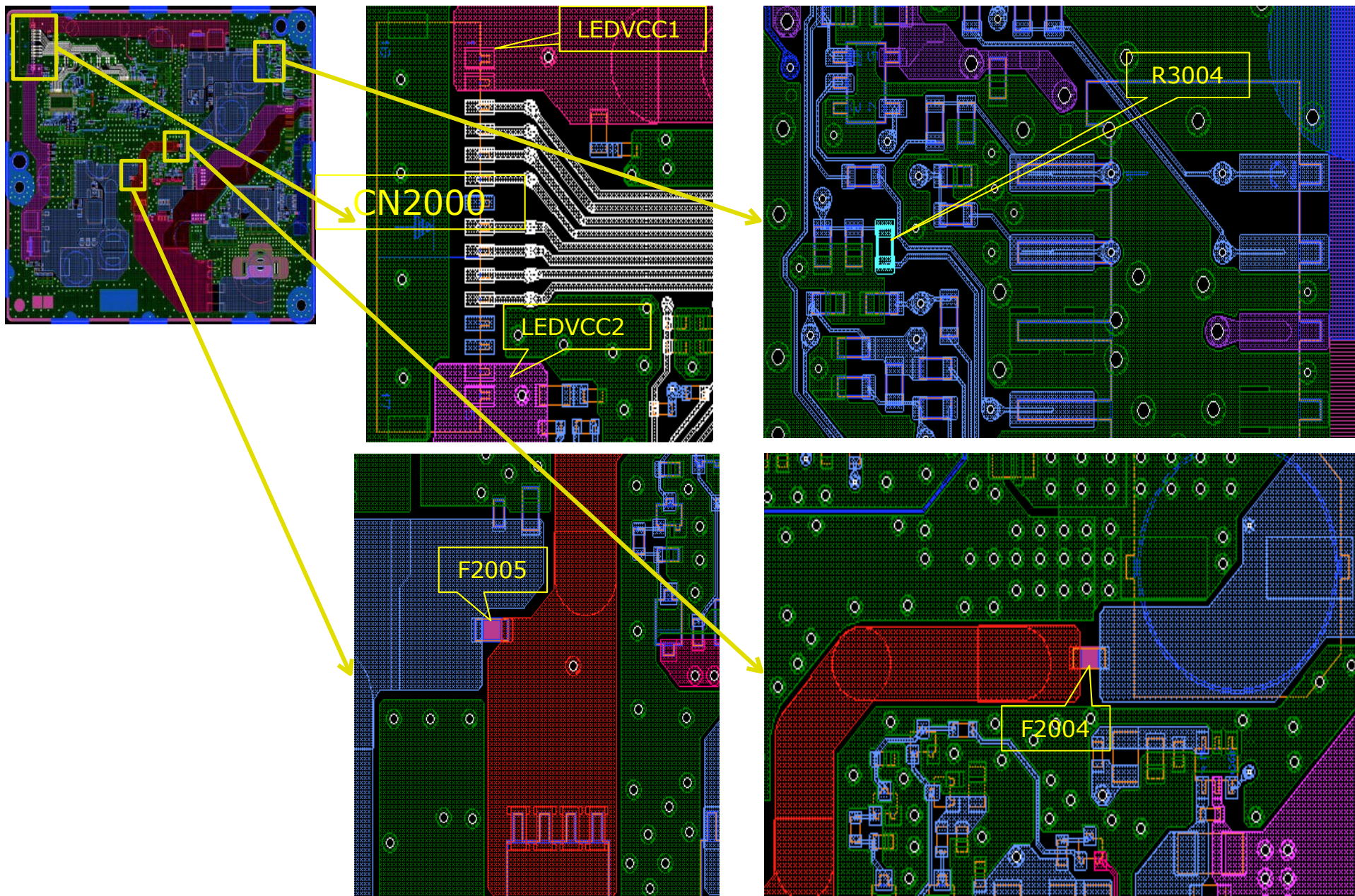

2.7 LED BLINKING: 7x (Temperature Error)

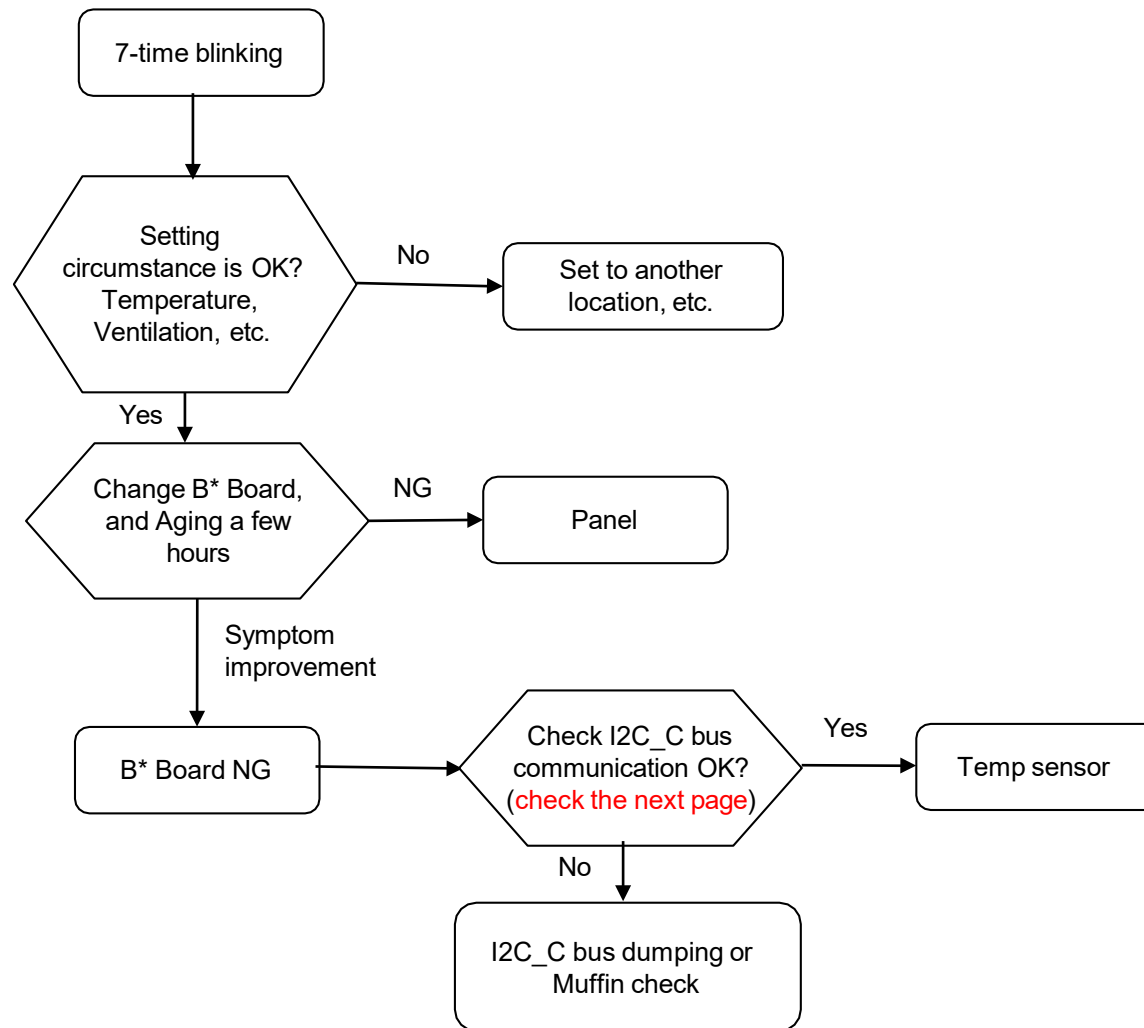

2.7 LED BLINKING: 7x (Temperature Error)

Check point for BCH

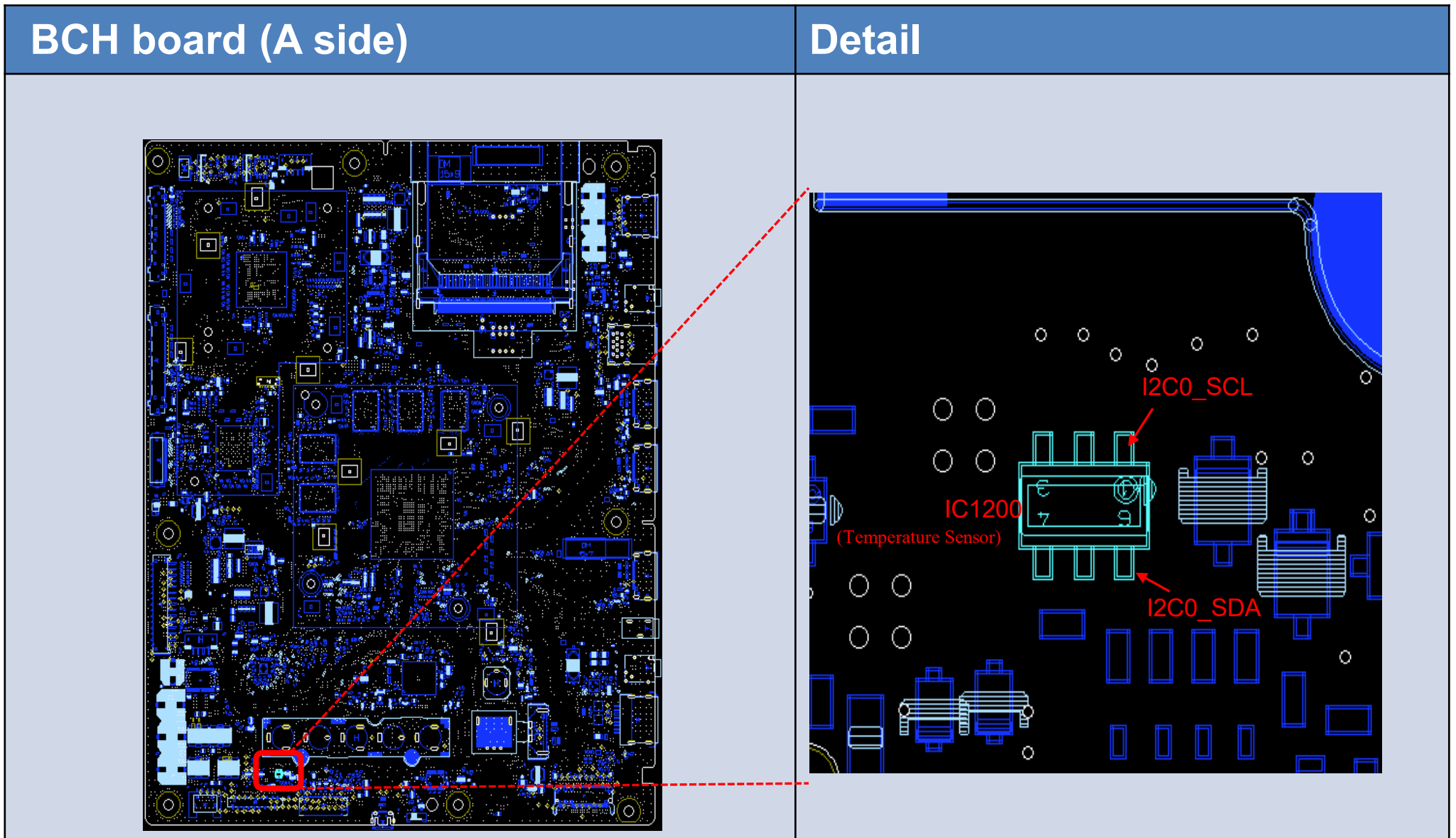

2.8 LED Blinking: 8x (4KPQ/BE Error)

LED Blinking: 8x (4KPQ Error)

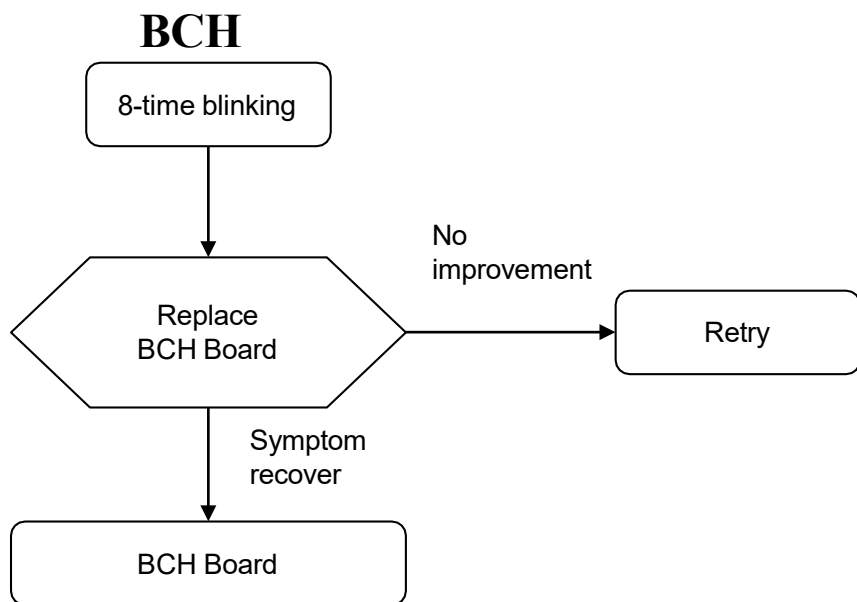

3.0 No Sound

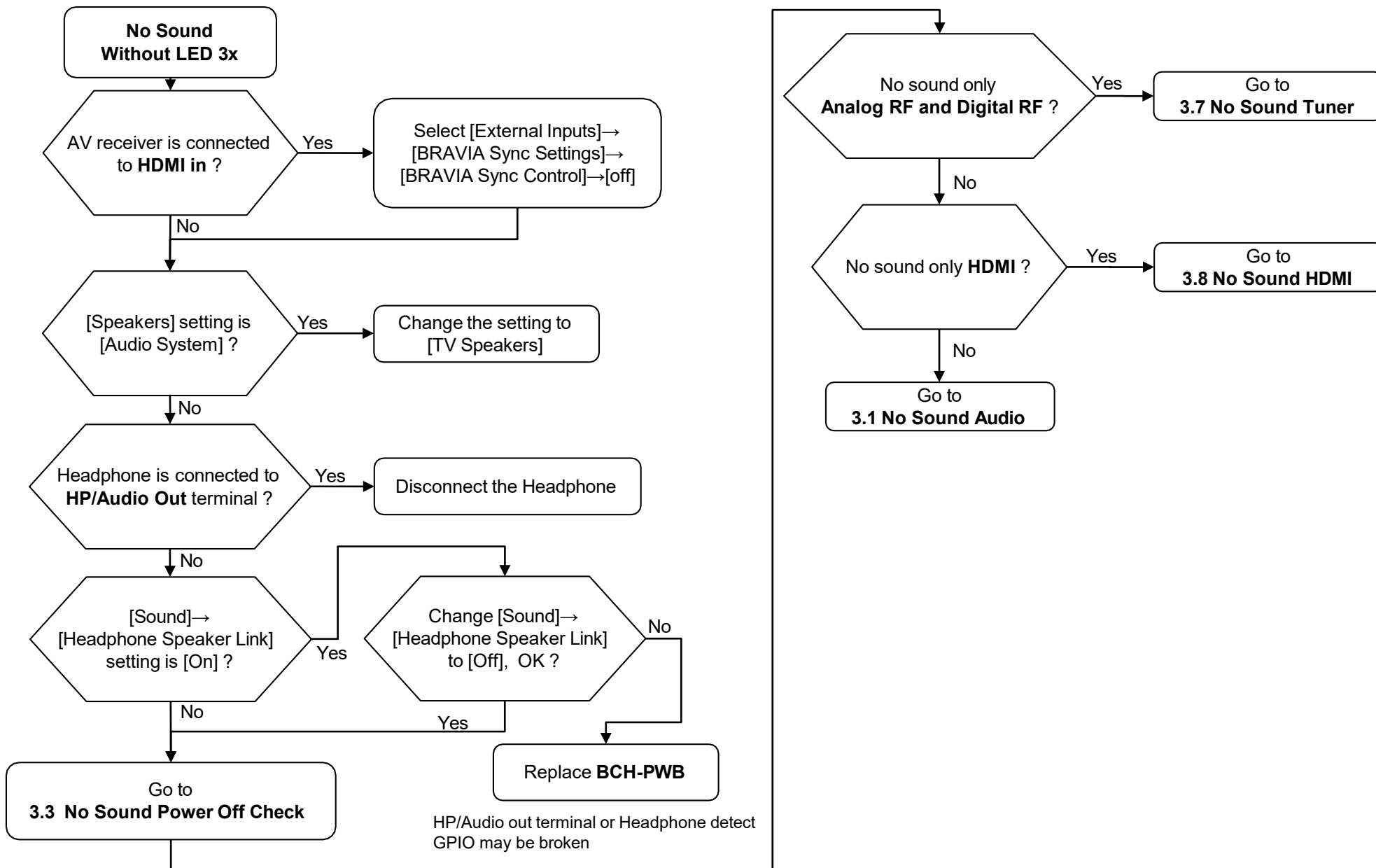

3.1 No Sound Audio

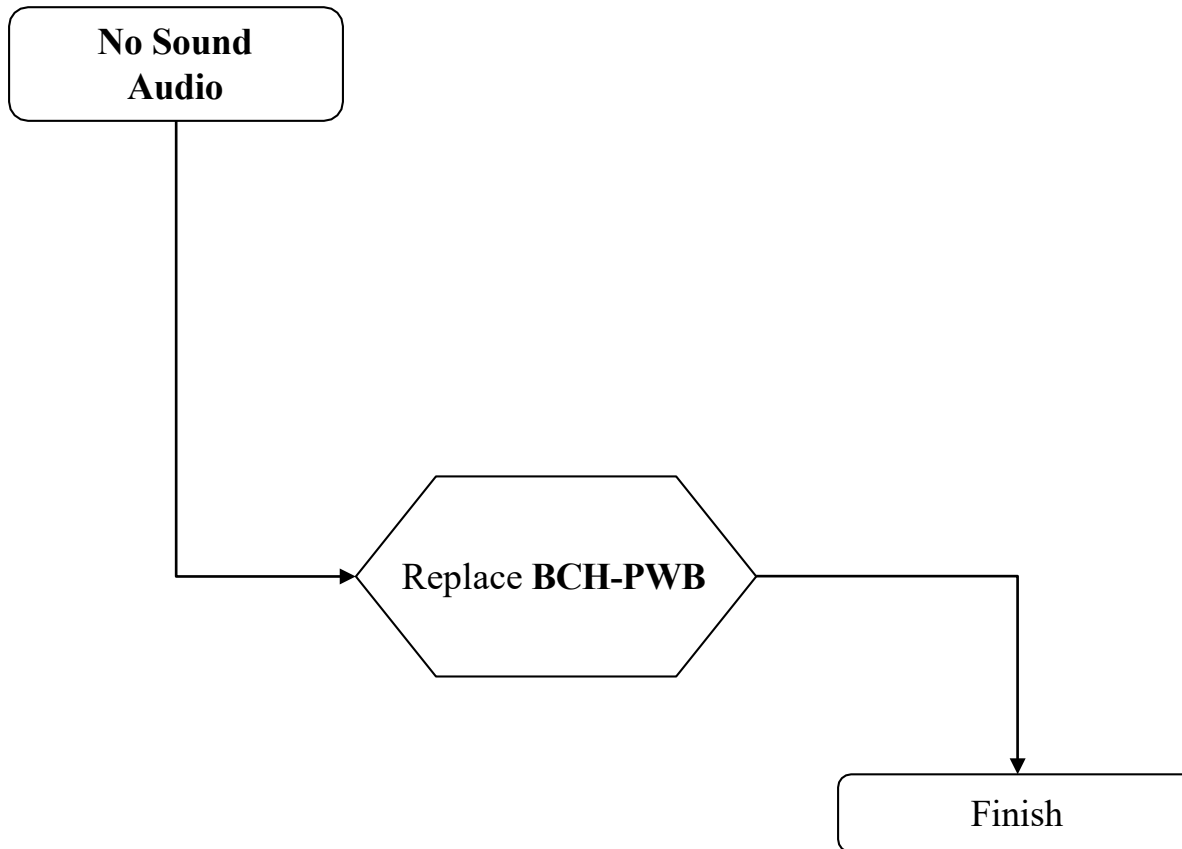

3.3 No Sound Power Off Check

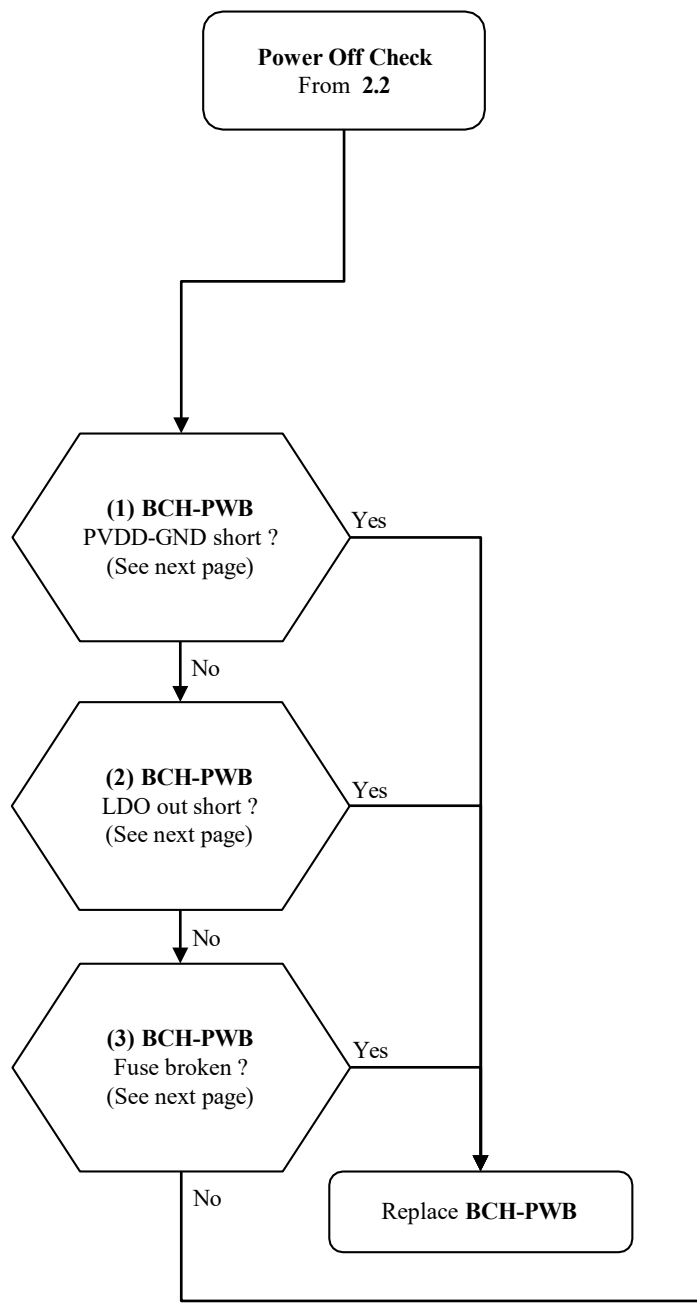

Speaker Impedance

	Rated Impedance	NG Value
KS/KH	8ohm	less than 6.4ohm

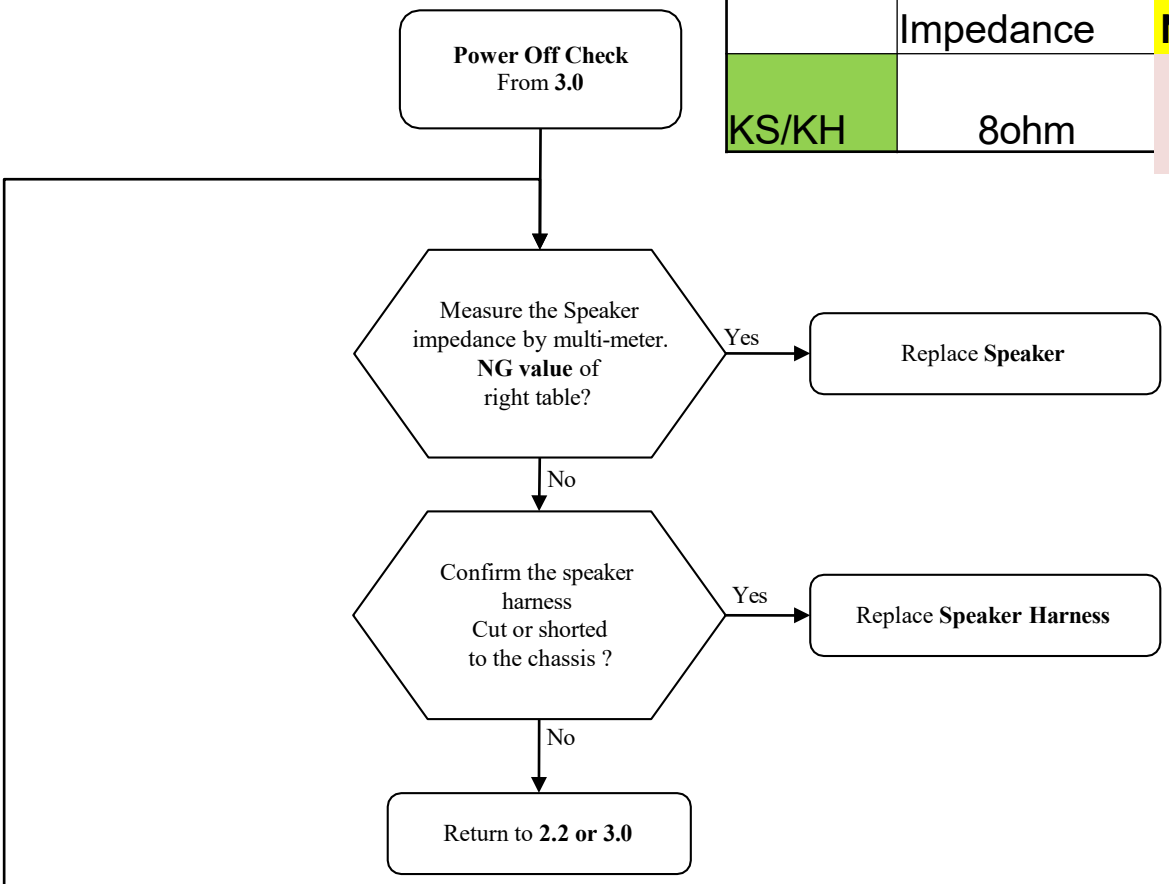

3.3 No Sound Power Off Check

BCH-PWB

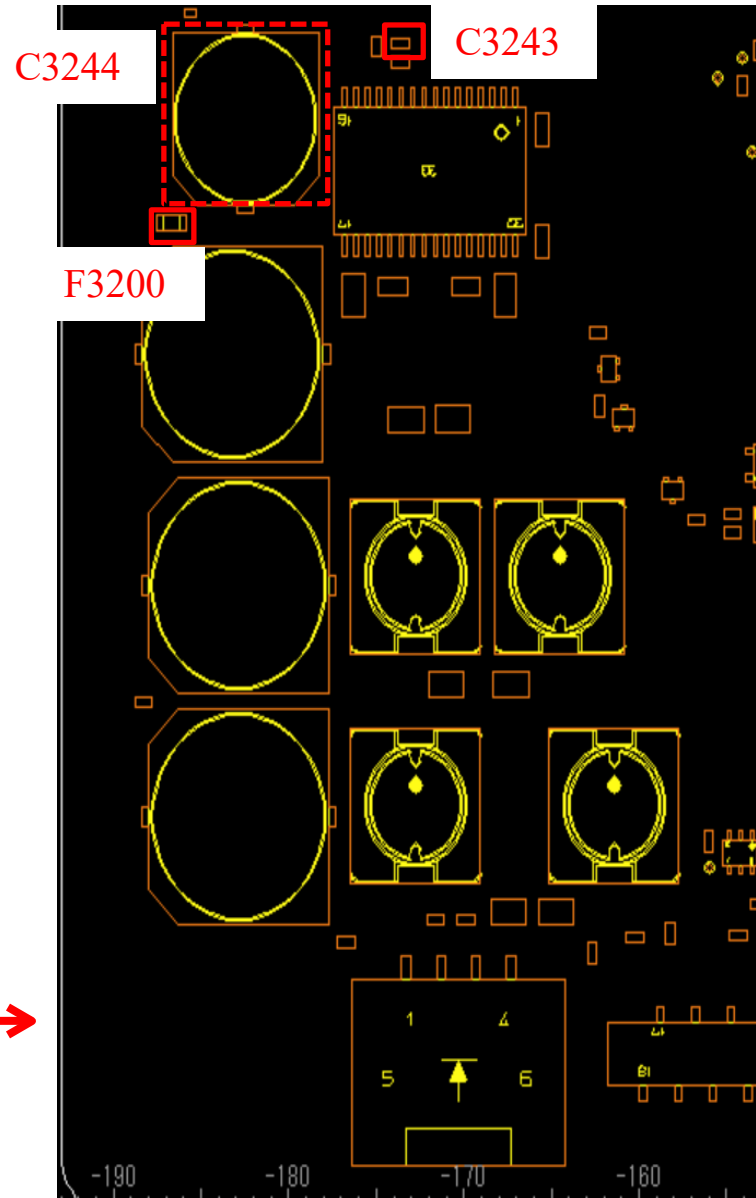
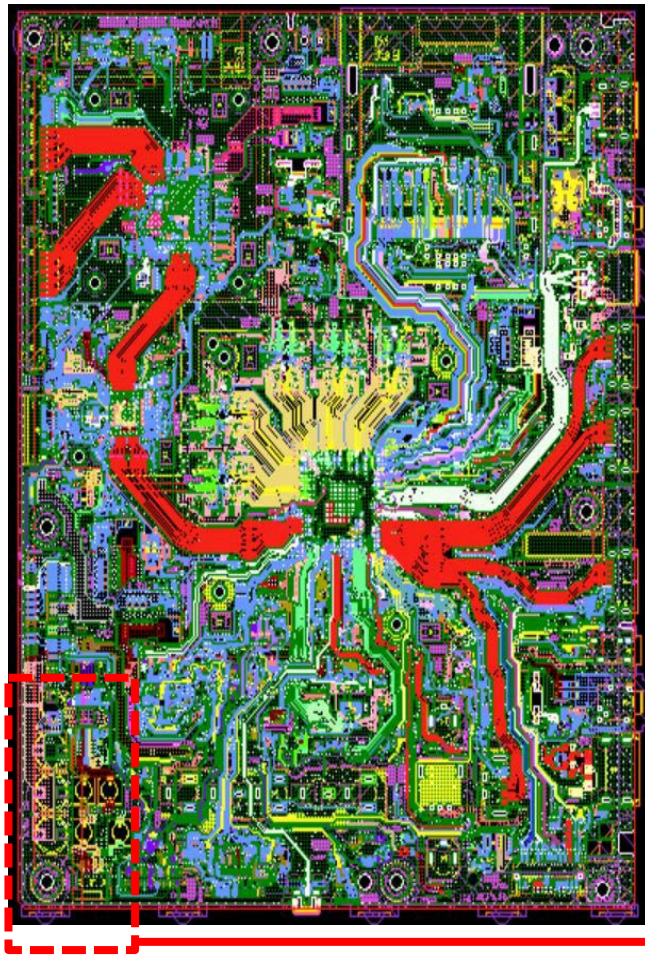

(1) PVDD-GND short check

Measure impedance between PVDD and GND at capacitor C3244.

After a few minutes waiting,
if impedance is $< 100\Omega$ → NG

(2) 3.3V short check

Measure +3.3V voltage at C3243.

If voltage is $< 2.7V$ → NG

(3) Fuse open check

Measure impedance of fuse F3200 5A .

If fuse open → NG

3.4 No Sound Power On Check

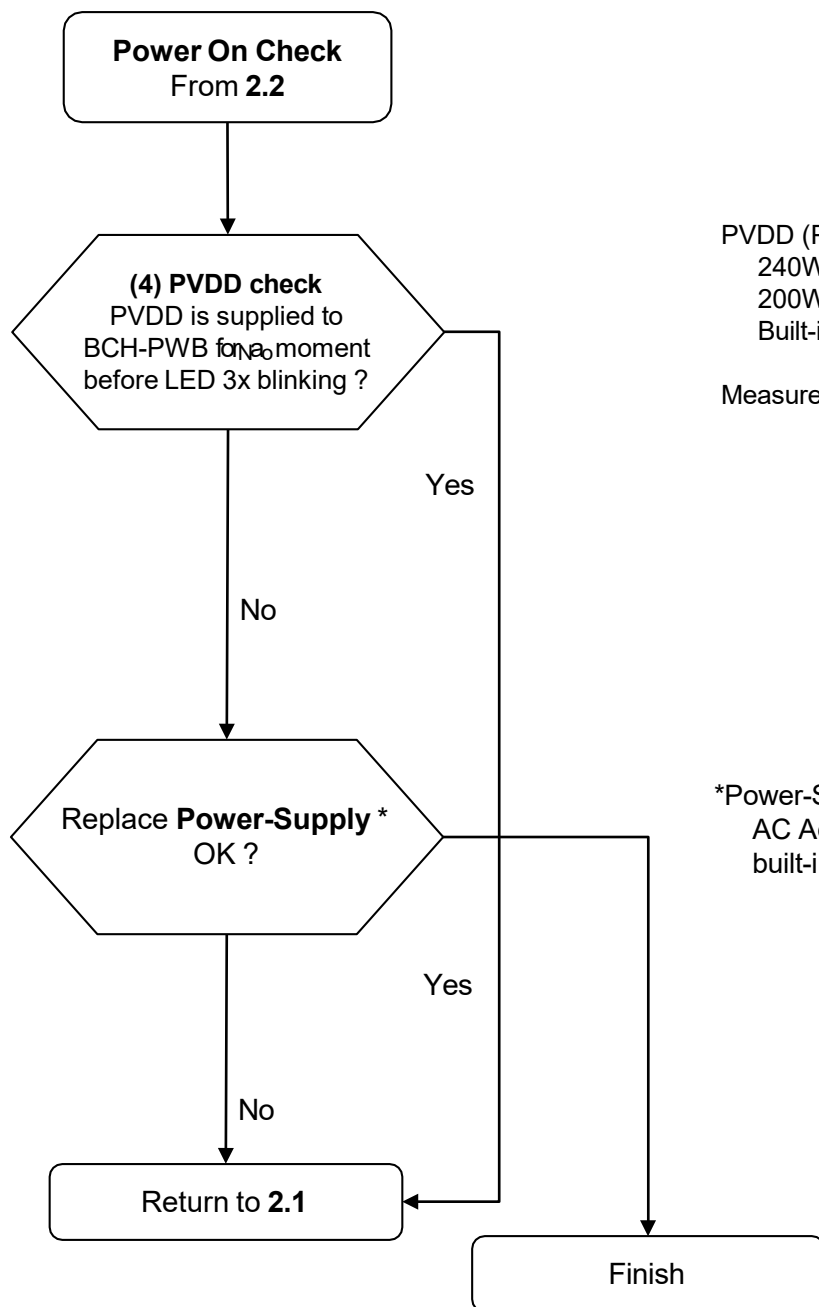

PVDD (POWER_AU) voltage is
 240W AC Adaptor model : 24.0V
 200W AC Adaptor model : 19.5V
 Built-in power supply model : 12.5V

Measurement point is same as **3.3 (1) PVDD-GND short check.**

*Power-Supply is
 AC Adaptor model : LD2-PWB & AC Adaptor
 built-in power supply model : G-PWB

3.5 No Sound Audio HP/Audio out

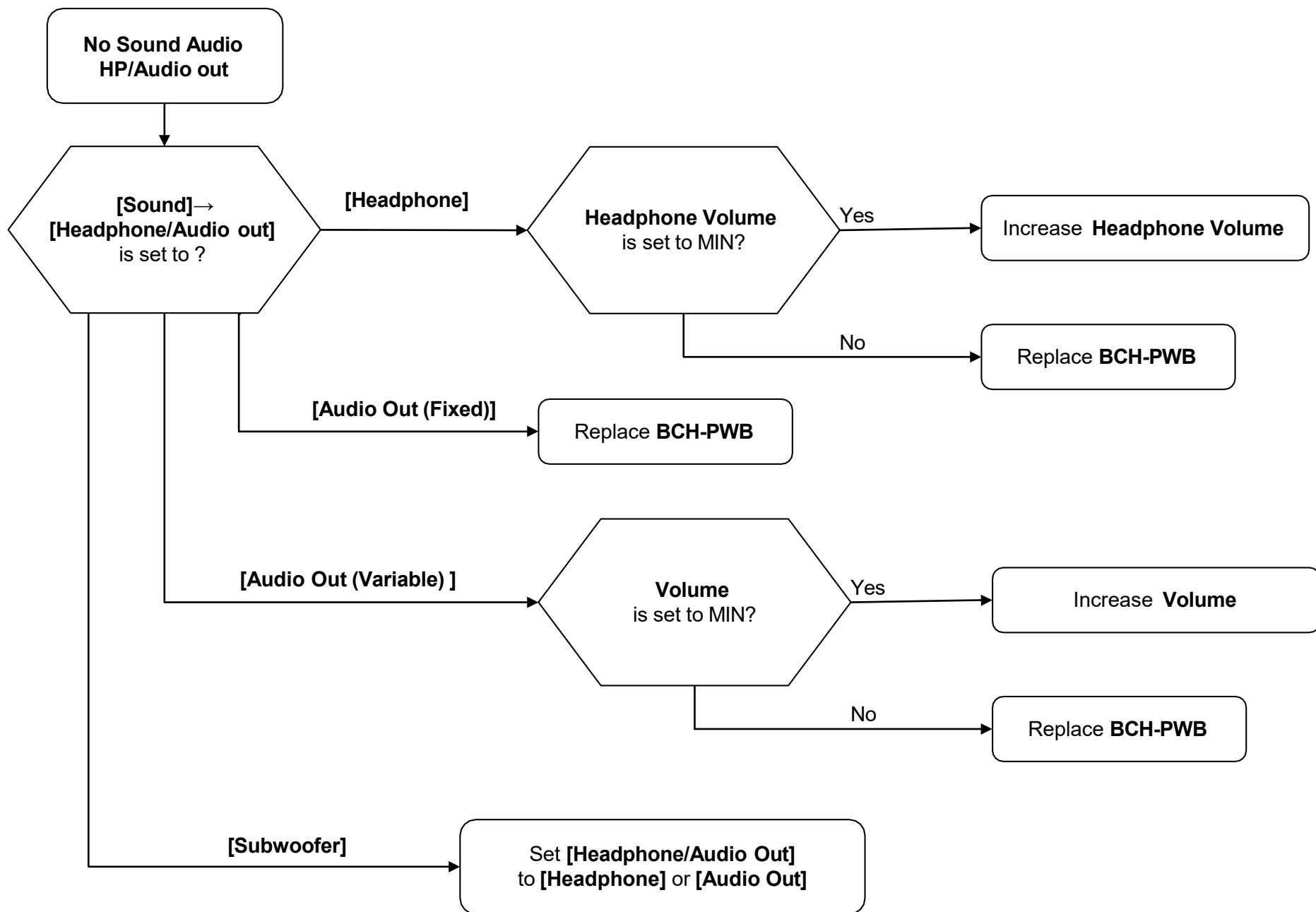

3.7 No Sound Tuner

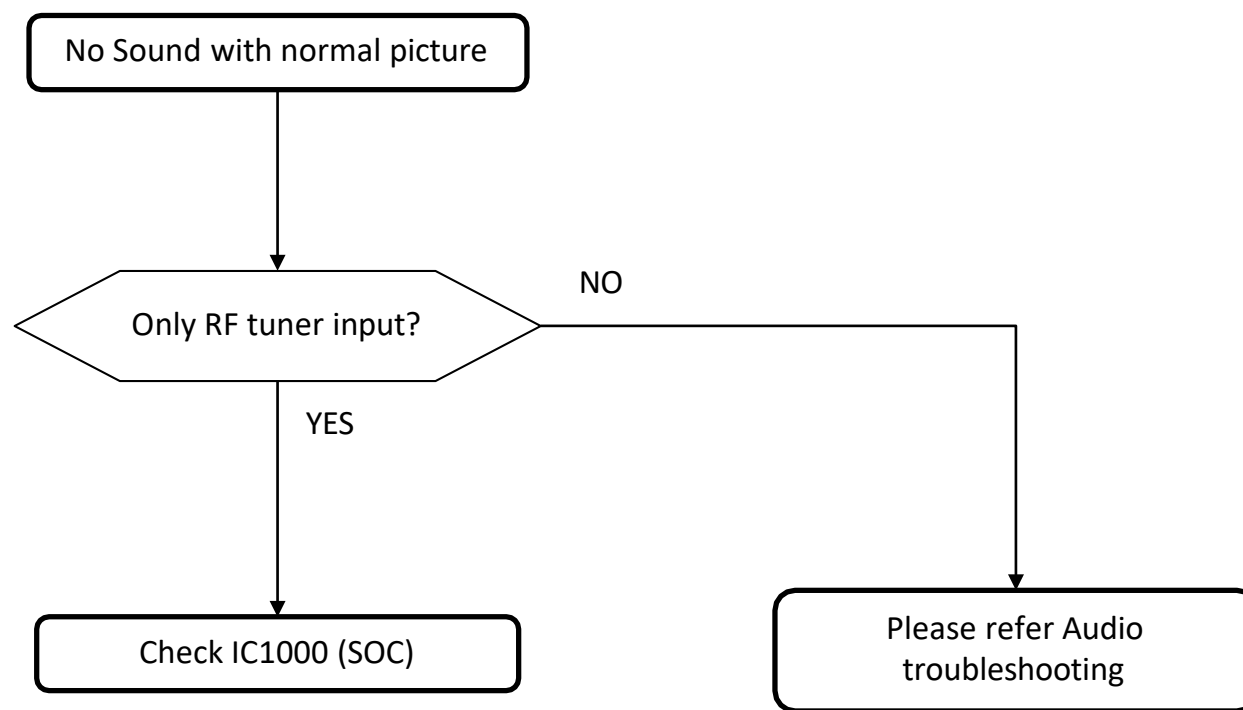

3.8 No Sound HDMI

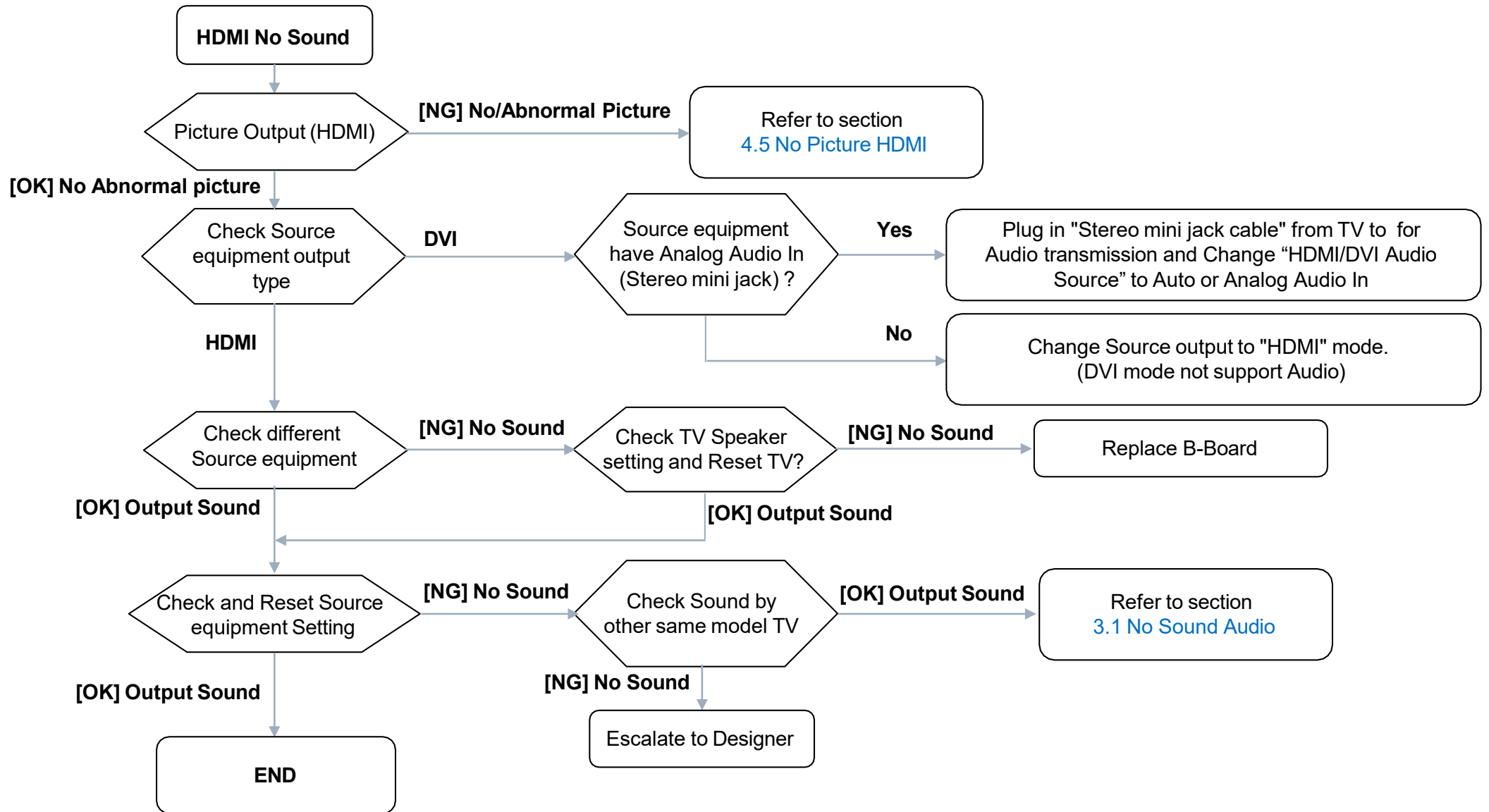

4.0 No Picture

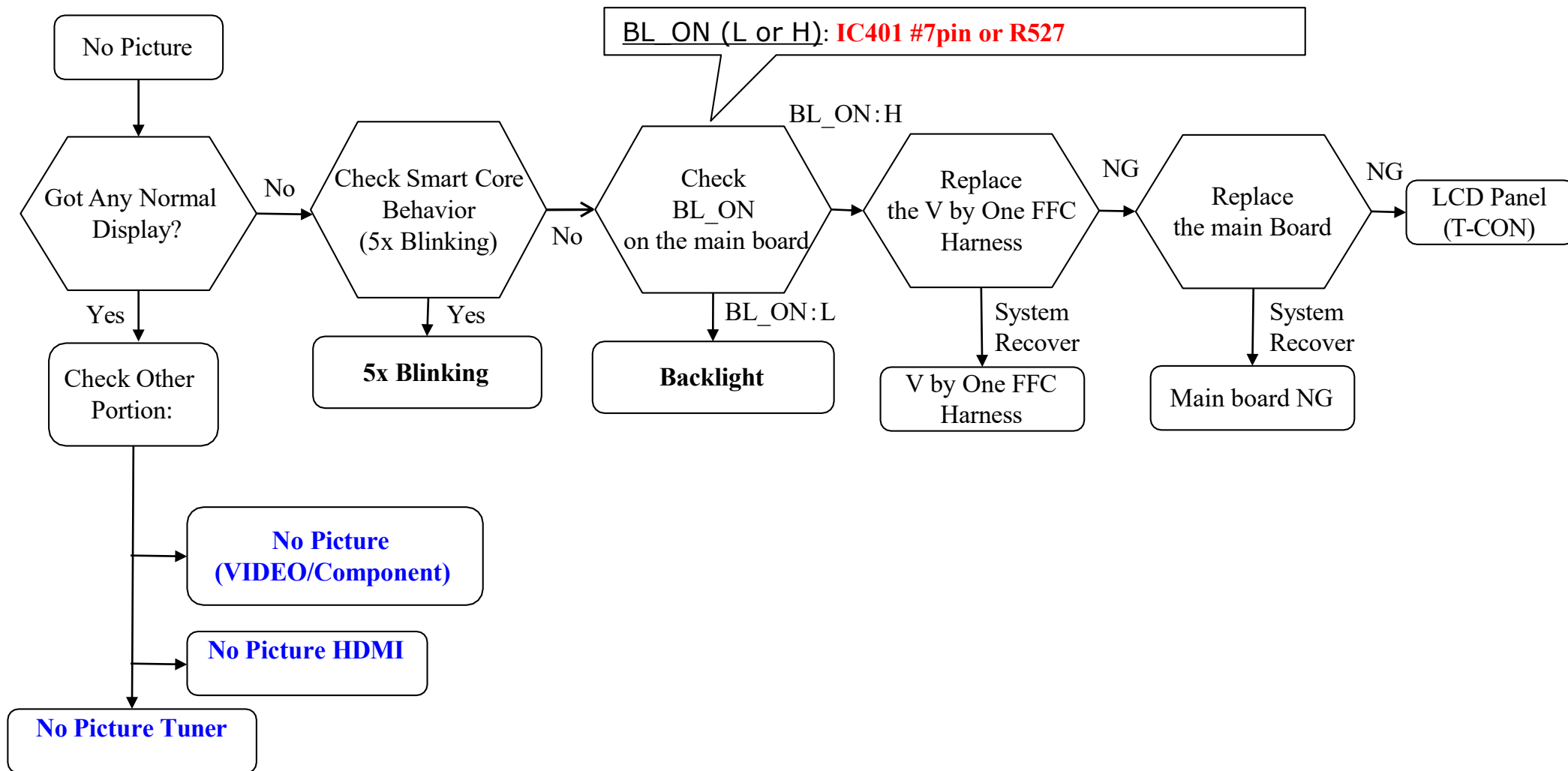

4.0 No Picture

Check point for BCH BL_ON (IC401 #7pin or R527)

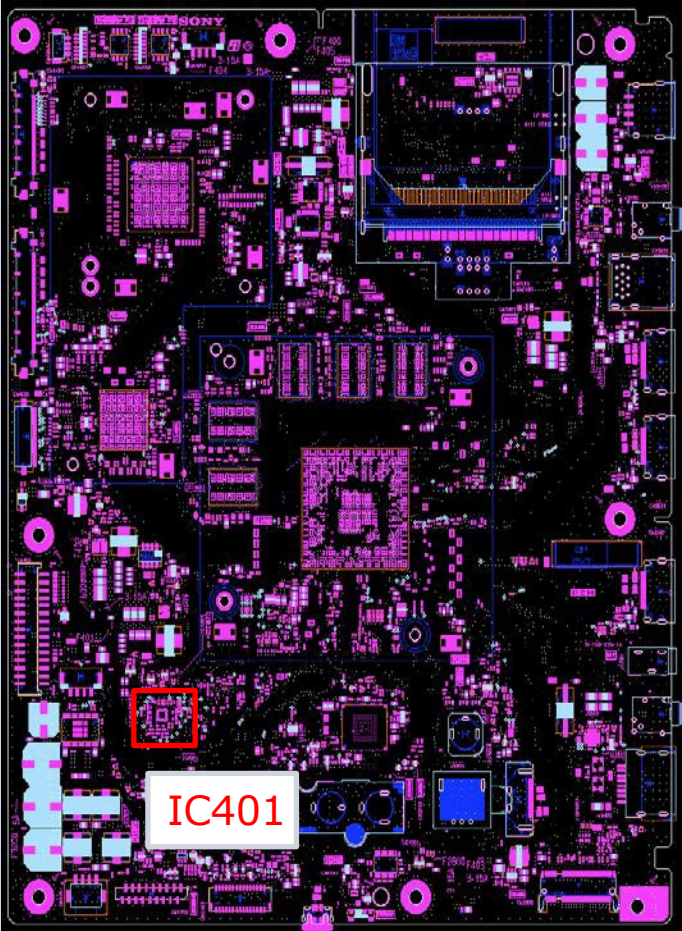
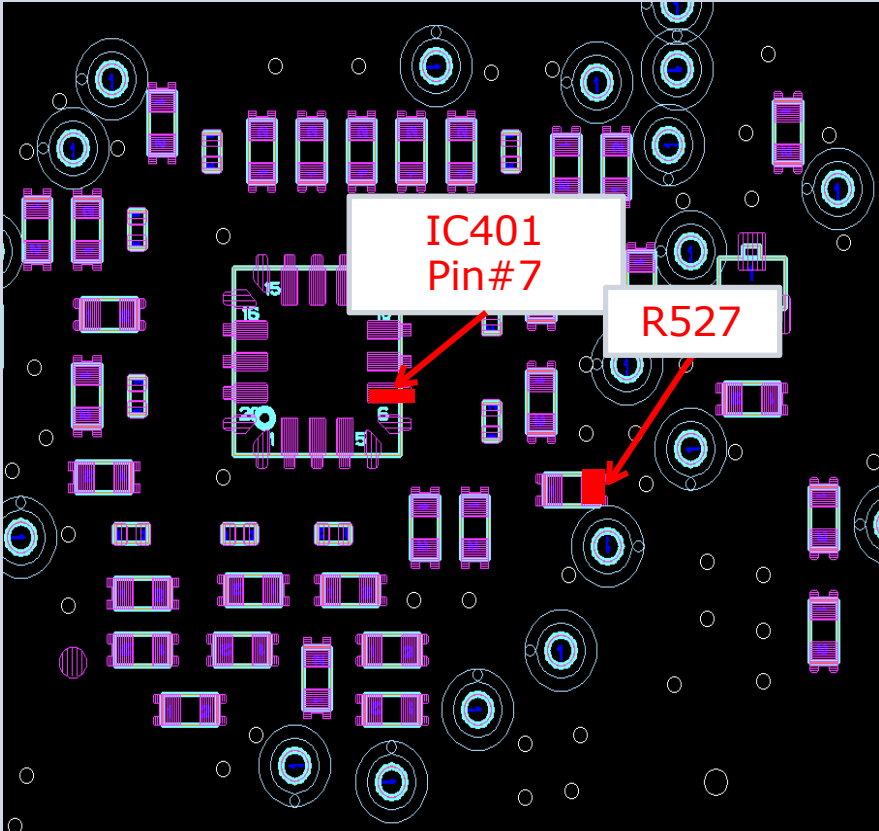
Name	Board PWB (A side)	Detail
BCH		

4.1 Video Analog Signal Path

There is no SCART terminal from FY17

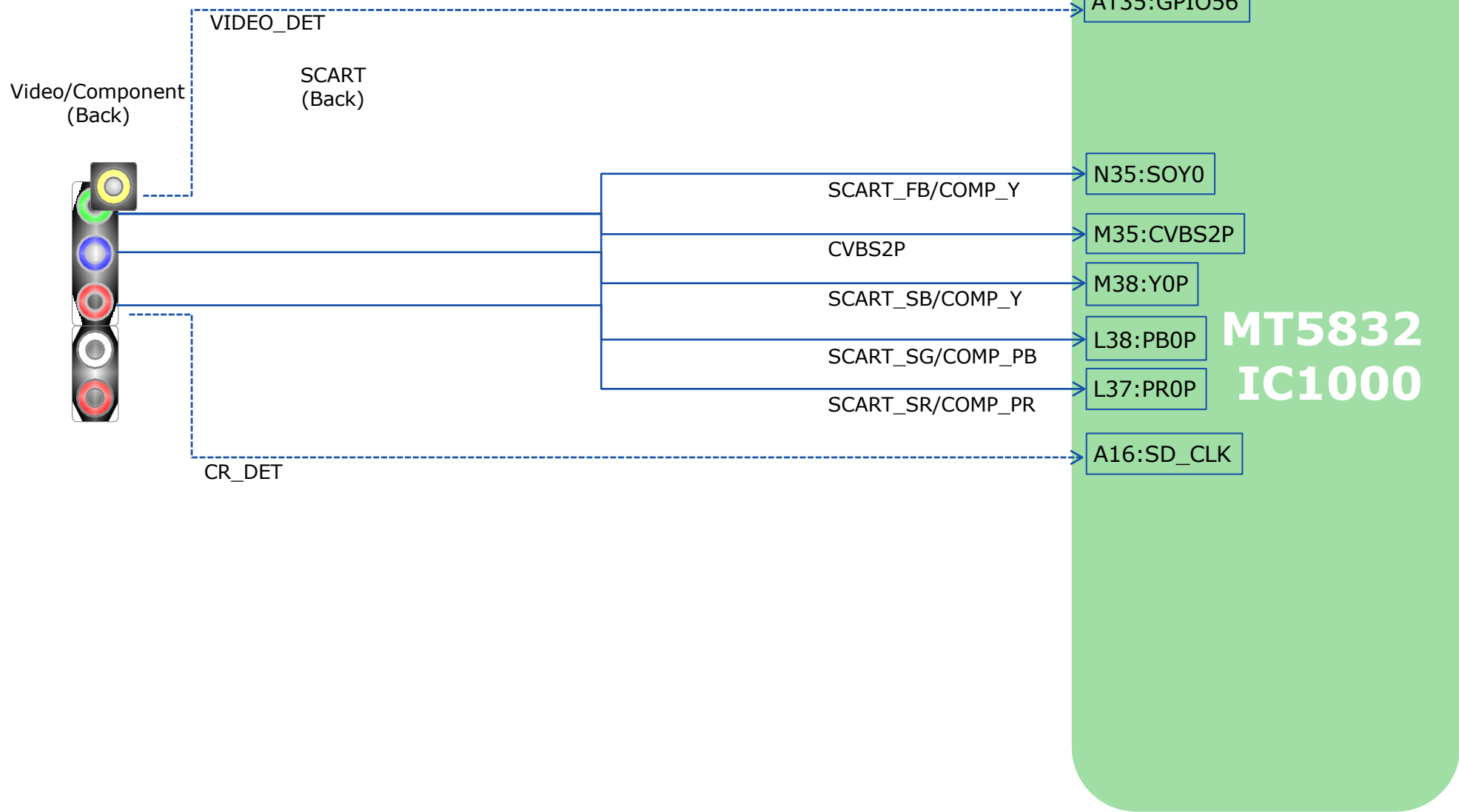

4.2 : No Picture (Component/Video)

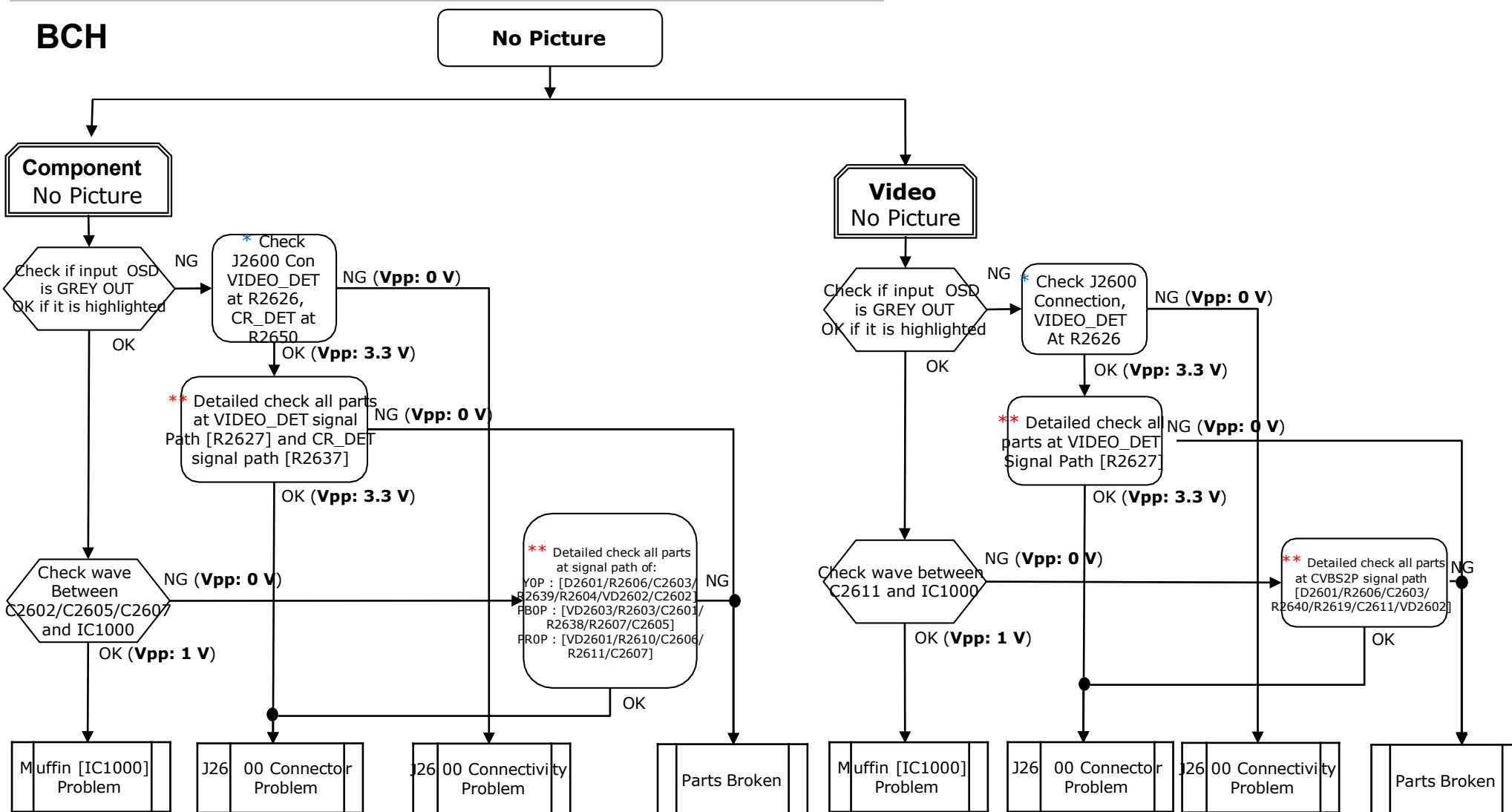

* → OK Condition : No solder splash can be seen
→ NG Condition : Solder splash can be seen

** → OK Condition : No part short-circuited
→ NG Condition : Part short-circuited

[All voltage measurement using Oscilloscope]

4.2 : No Picture (Component/Video)

Condition		Actions to be taken
	Muffin [IC1000] Problem	Refer to IC troubleshooting for further investigation
	J2600 Connector Problem	
	J2600 Connectivity Problem	Change Connector
	Parts Broken	
		Change Part

4.2 : No Picture (Component/Video)

Input Skip function (BCH)

Input	Signal	Non-Detect (Typical)	Detect (Typical)
Component /Video	VIDEO_DET IC1000 AT35-GPIO56	0V	3.3V
	CR_DET IC1000 A16-SD_CLK	0V	3.3V

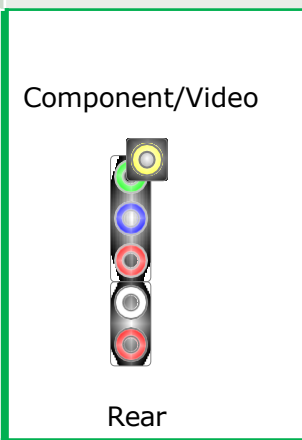

Except AEP

4.4 No Picture Tuner

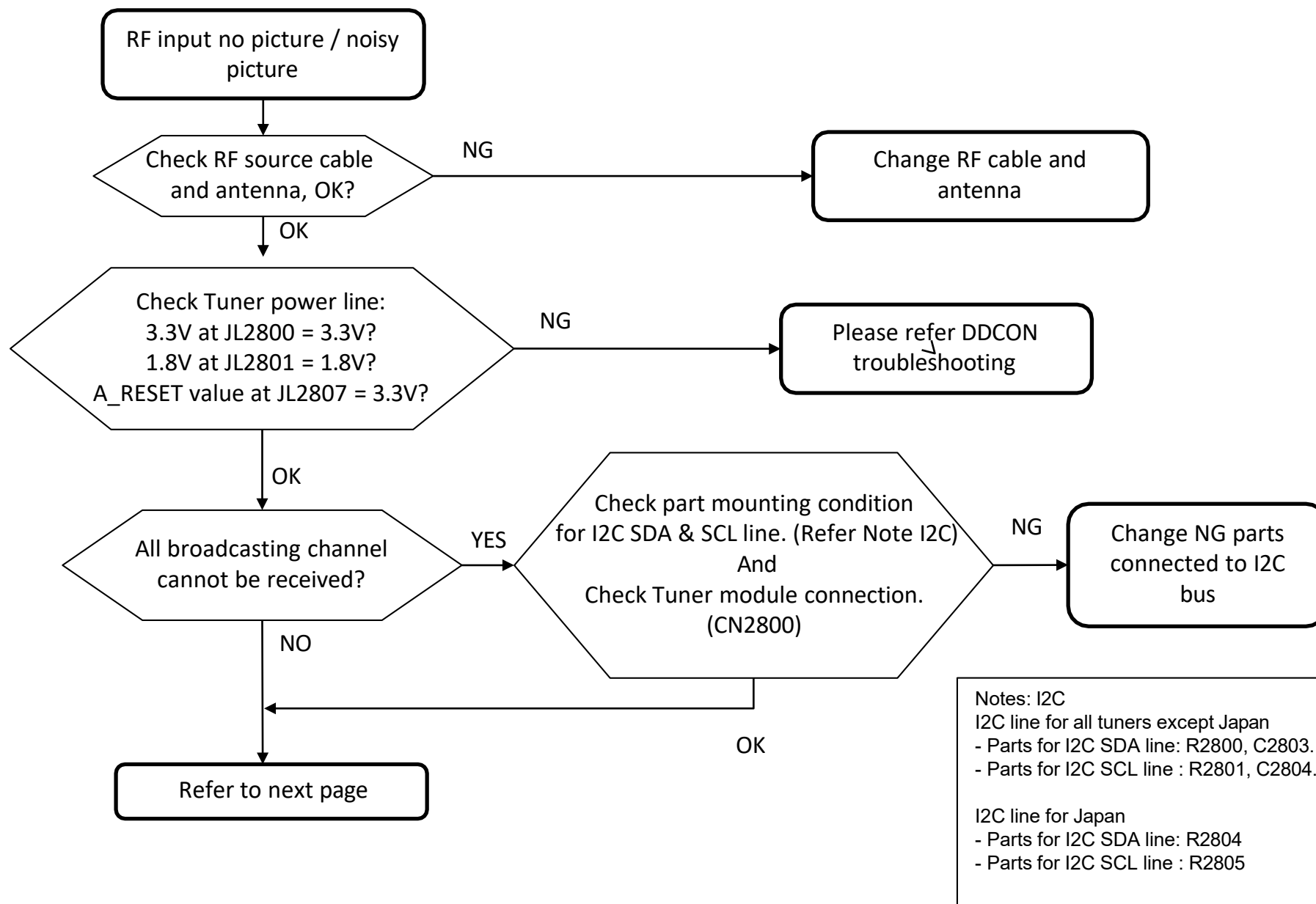

4.4 No Picture Tuner

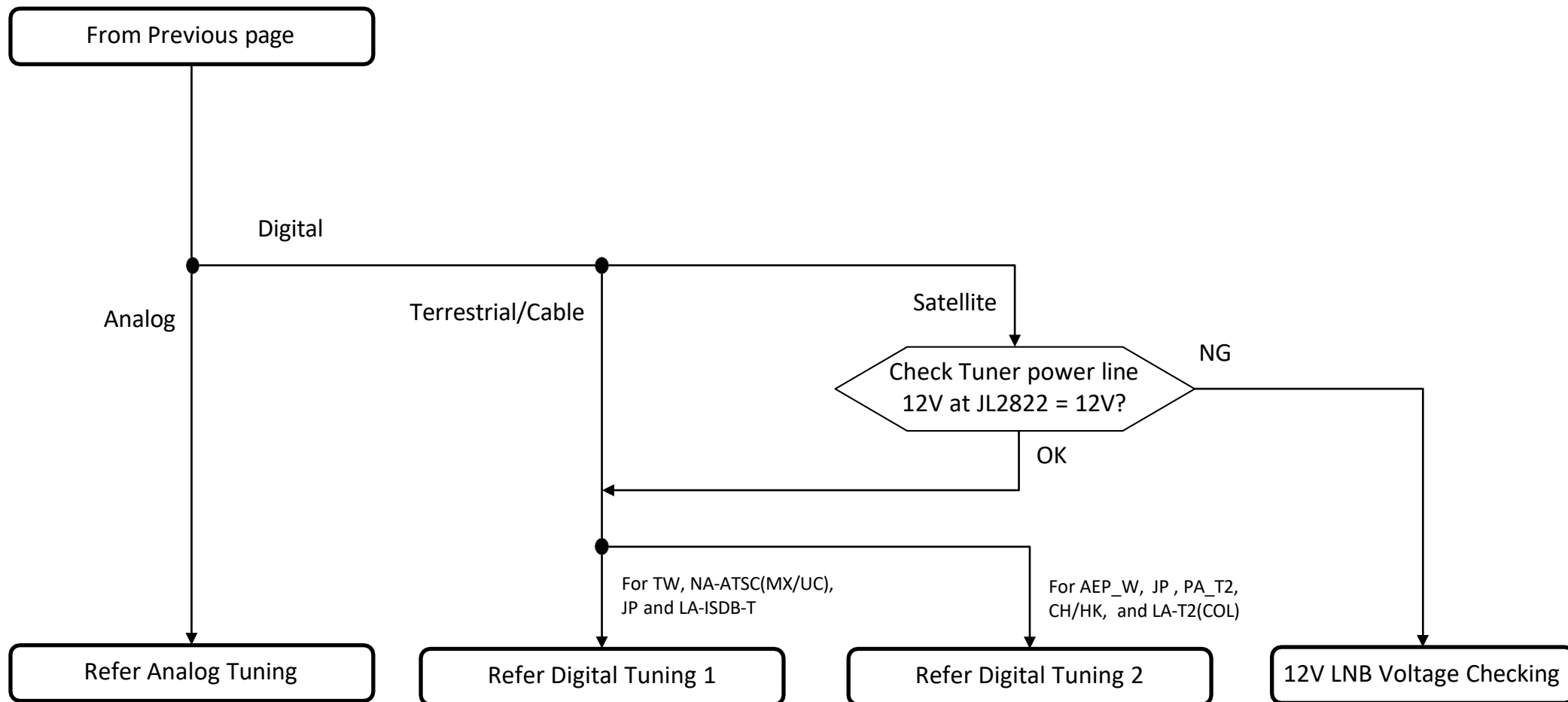

4.4 No Picture Tuner

BCH (Top View) For Tuner Power Lines

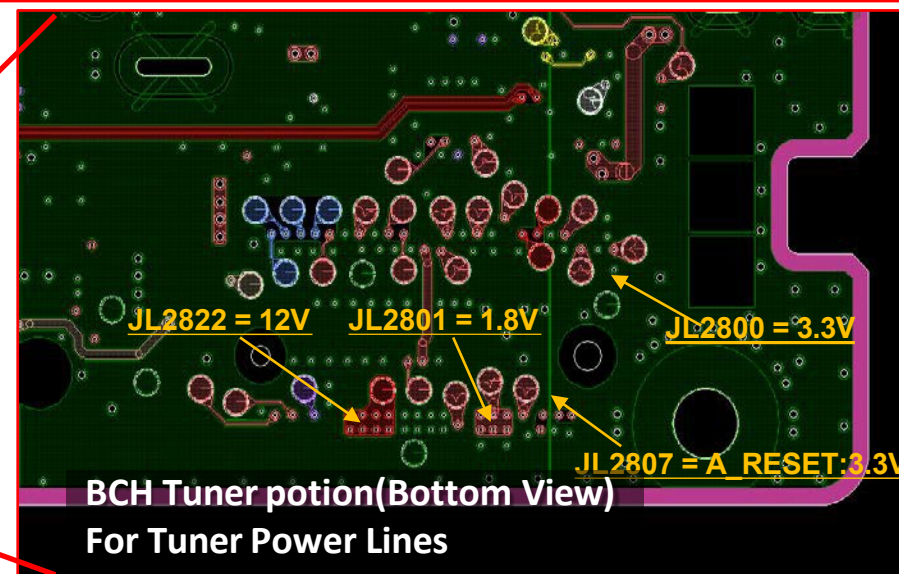
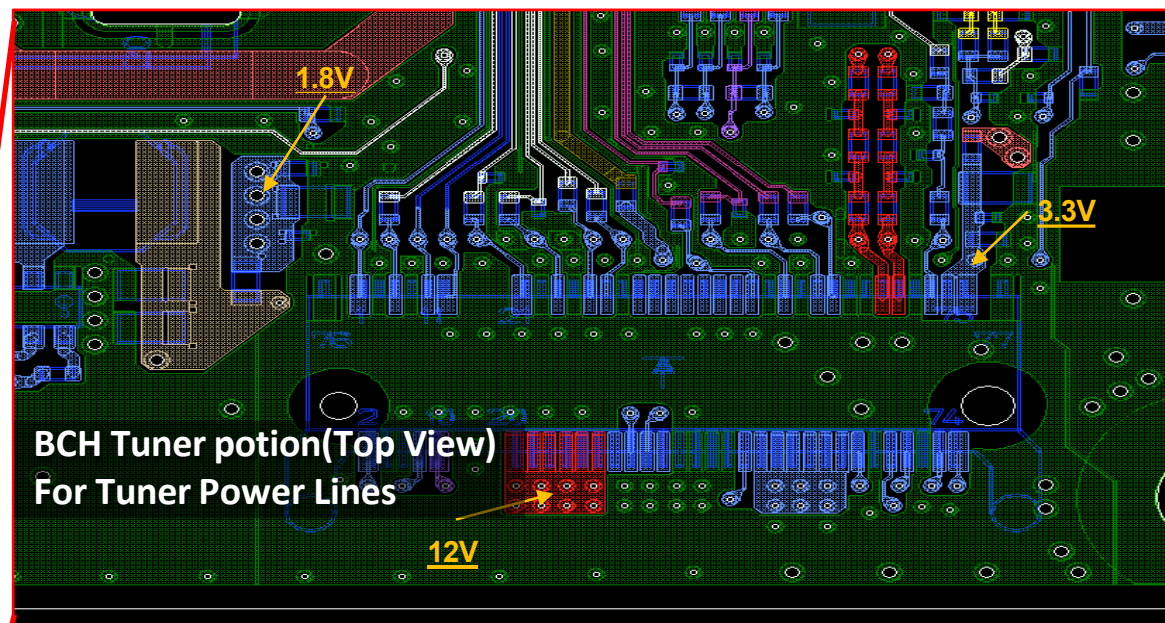
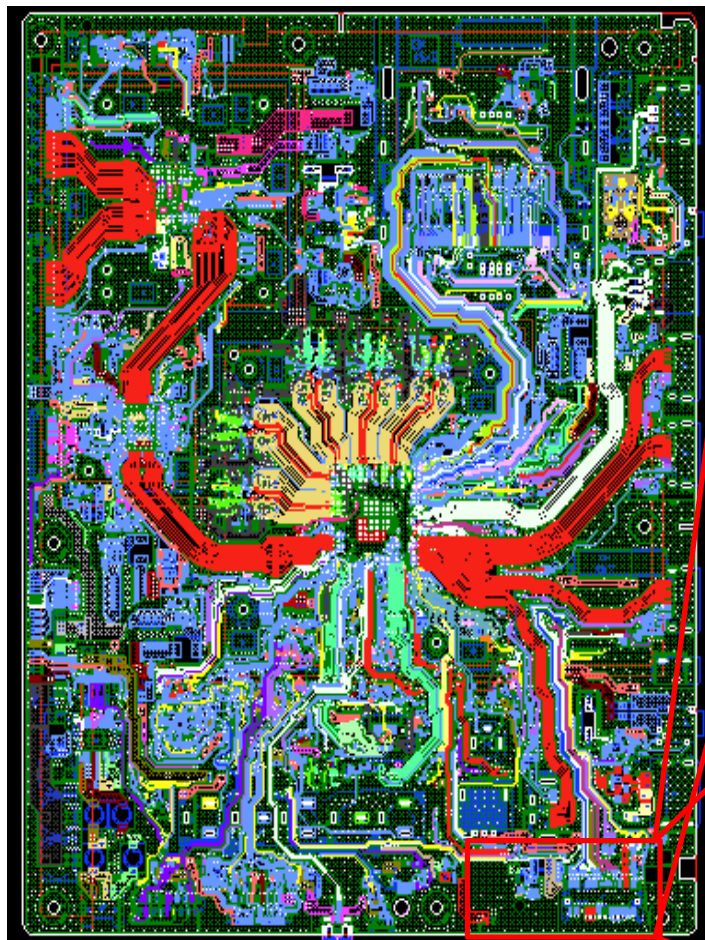

4.4 No Picture Tuner

BCH (Top View) For Tuner I2C line

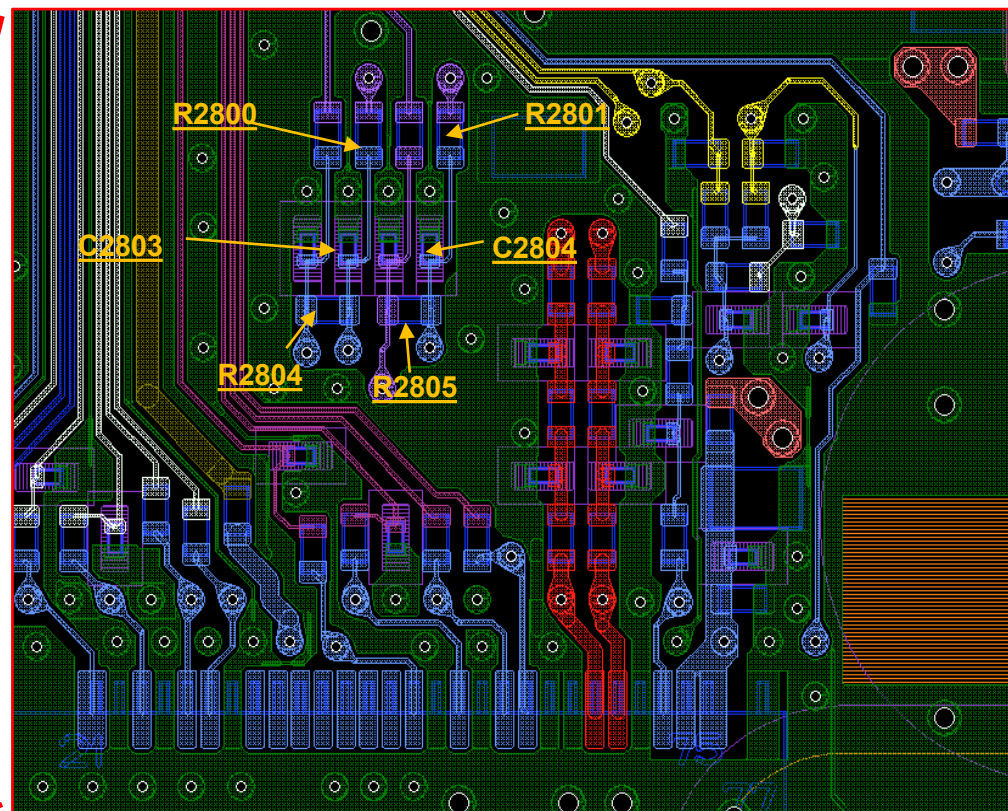
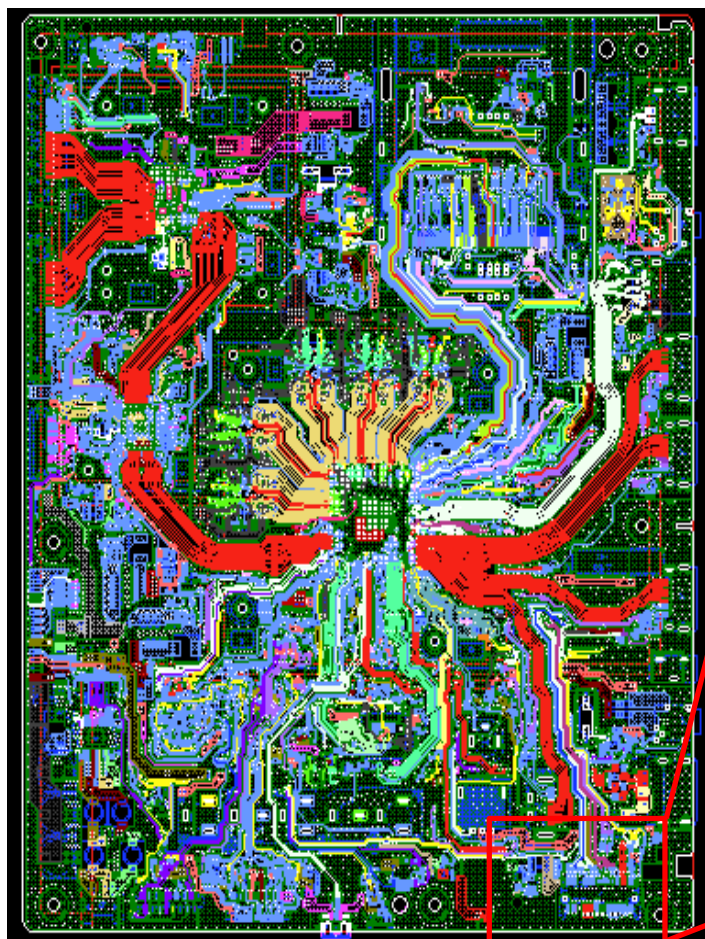

4.4 No Picture Tuner

FOR 12V LNB Voltage Checking: @ AEP_W and JP

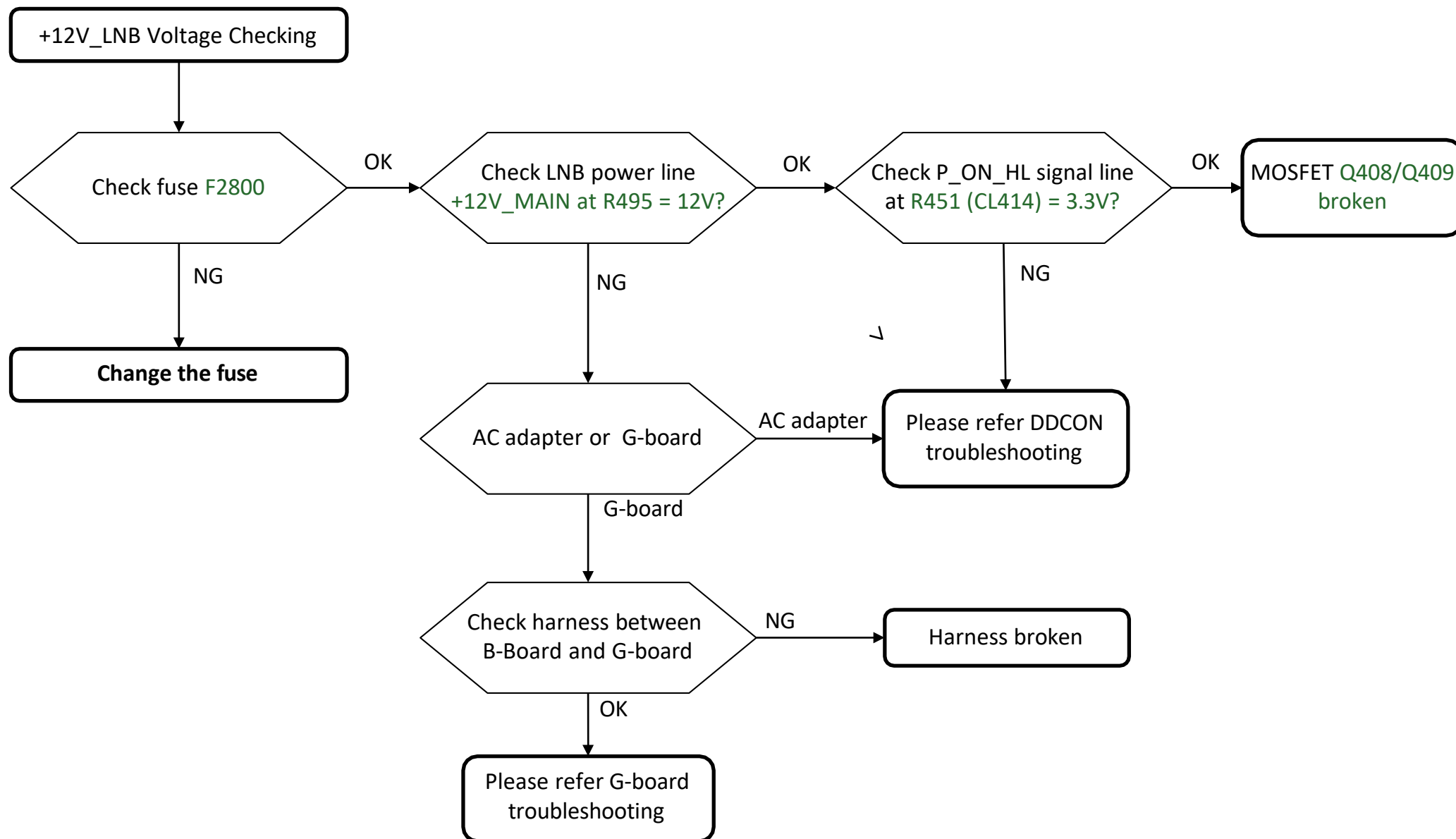

4.4 No Picture Tuner

BCH (Top View) 12V LNB Voltage line

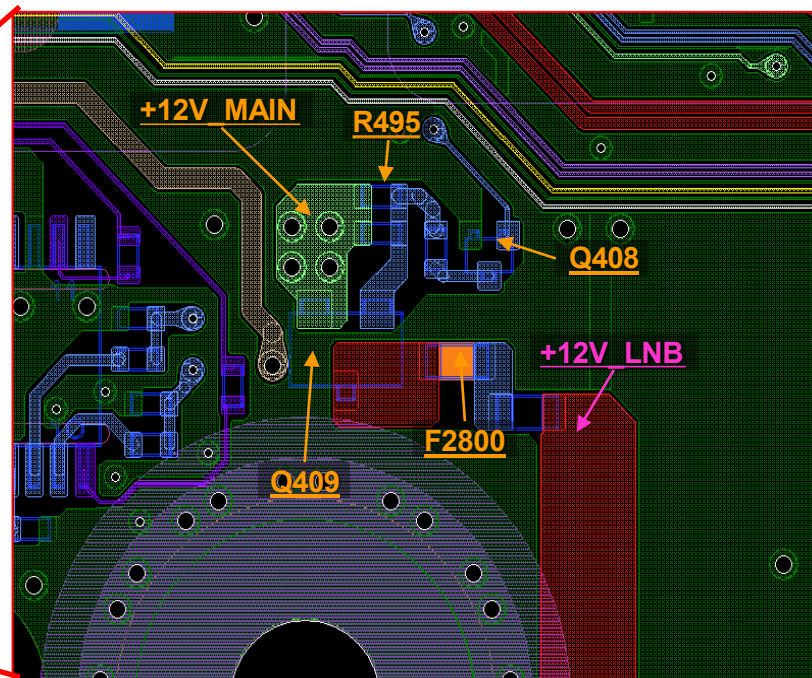
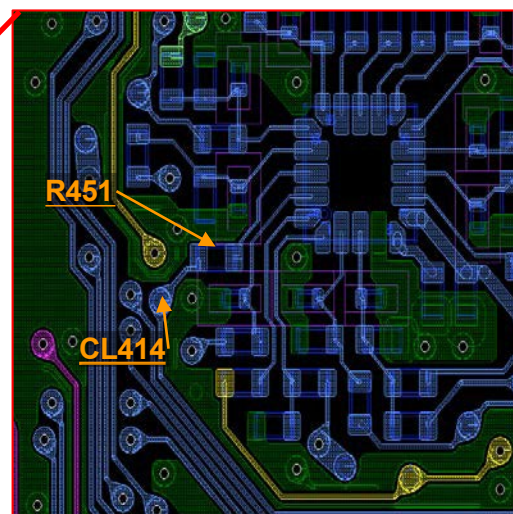
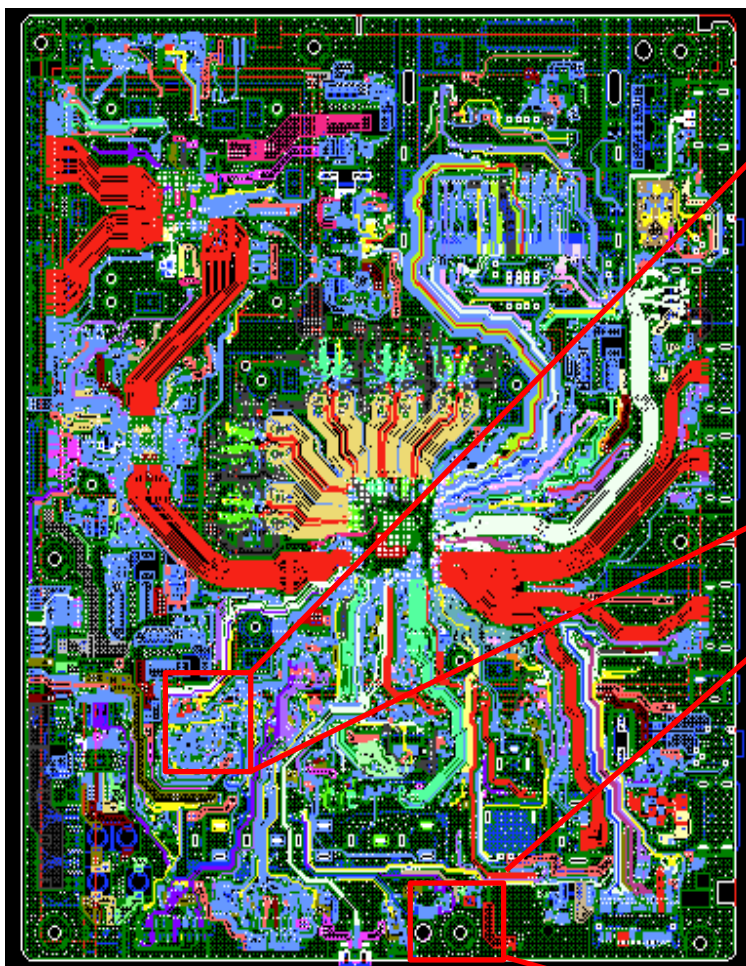

4.4 No Picture Tuner

FOR ANALOG TUNING: @ All destination except JP

Notes:
 - Parts for IFOUT_N line : FB2801, C2807, C2826
 - Parts for IFOUT_P line : FB2802, C2808, C2825
 - Parts for IFAGC line : R2838, C2827

(A) : Insert correct signal in correct terminal.

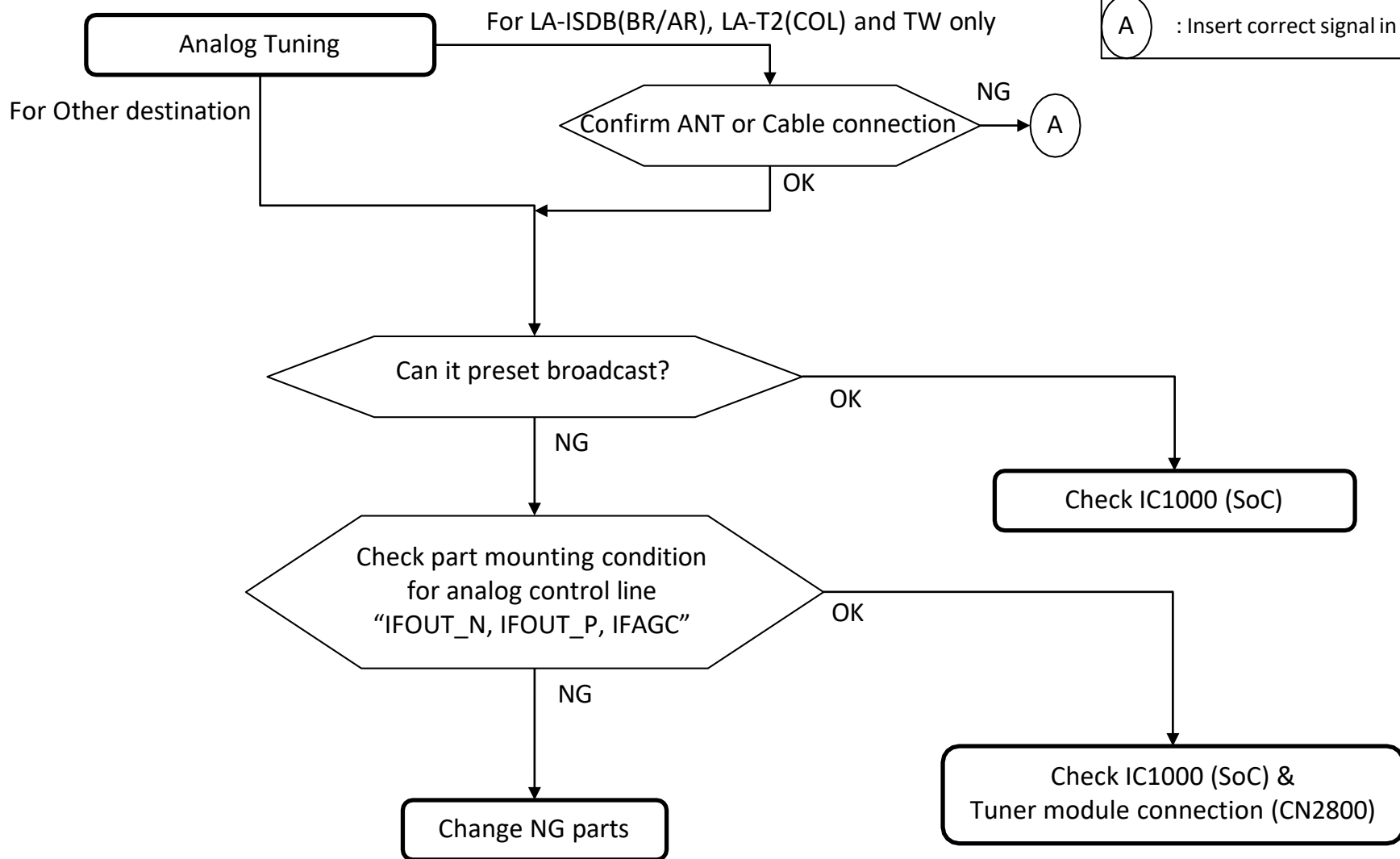

4.4 No Picture Tuner

FOR DIGITAL TUNING 1: @ TW, NA-ATSC(MX/UC), JP and LA-ISDB-T.

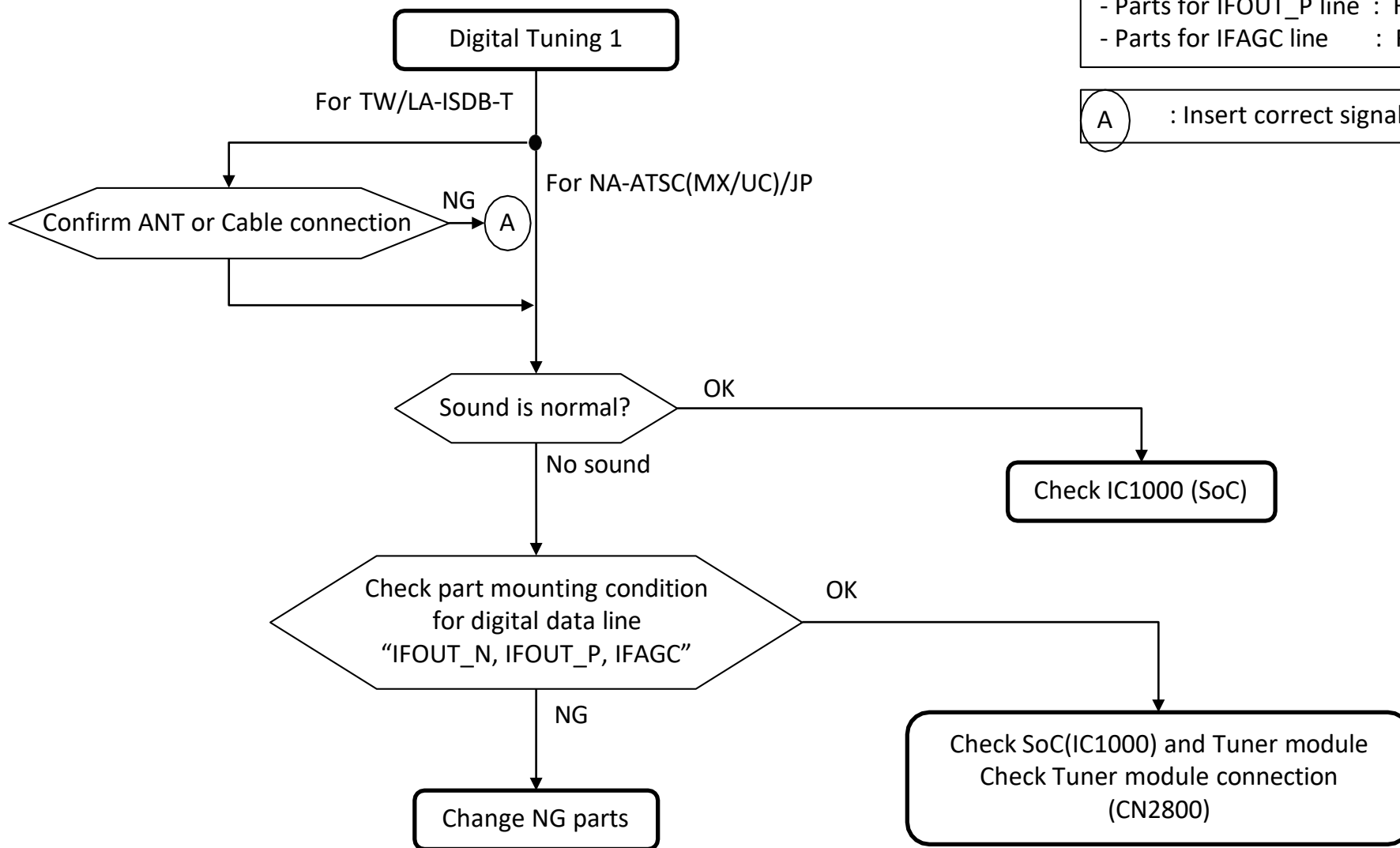

Notes:
 - Parts for IFOUT_N line : FB2801, C2807, C2826
 - Parts for IFOUT_P line : FB2802, C2808, C2825
 - Parts for IFAGC line : R2838, C2827

(A) : Insert correct signal in correct terminal.

4.4 No Picture Tuner

BCH(Top View) IF & IFAGC line

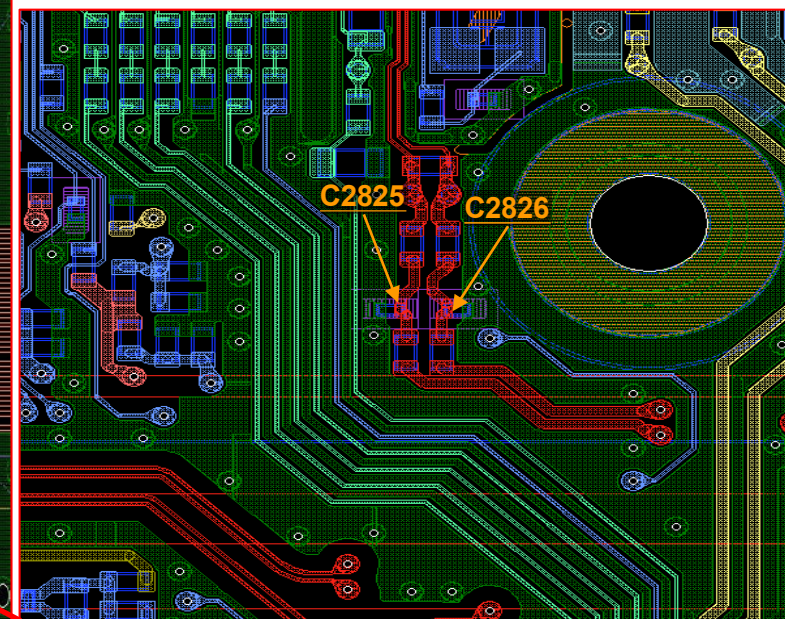
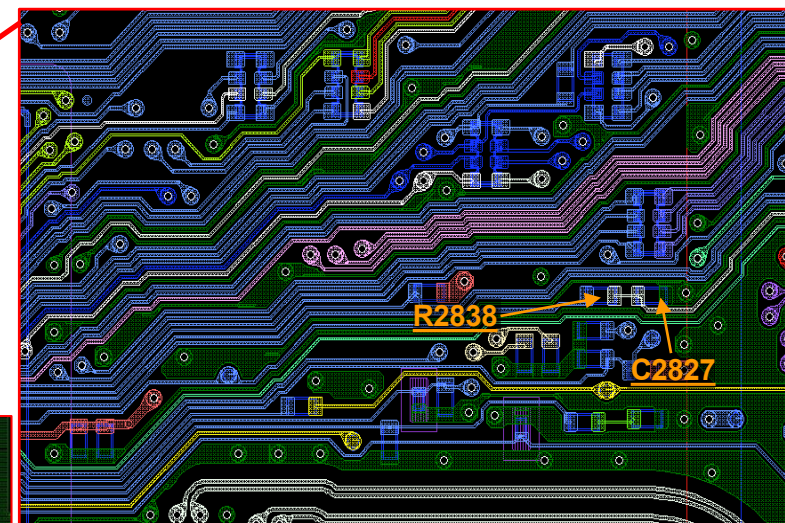
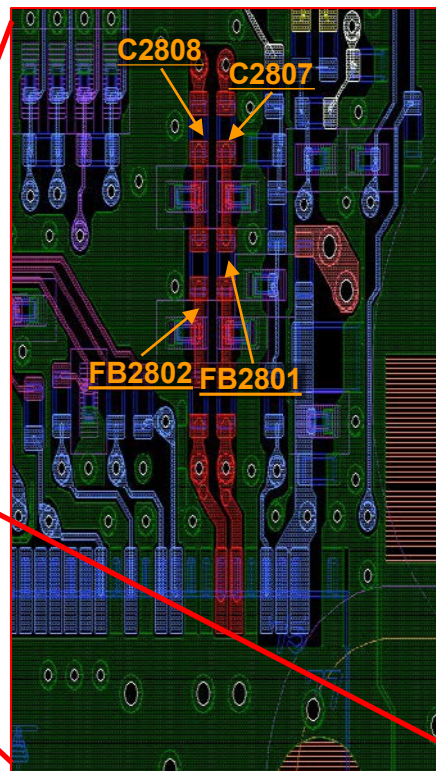
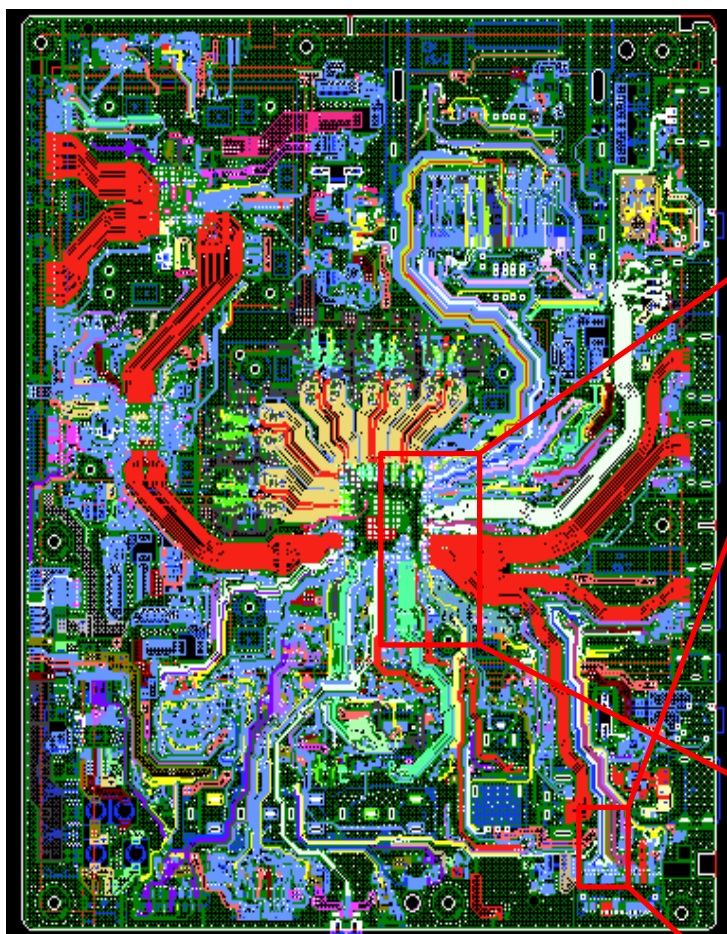

4.4 No Picture Tuner

FOR DIGITAL TUNING 2: @ AEP_W, JP, PA_T2, CH/HK, and LA-T2(COL)

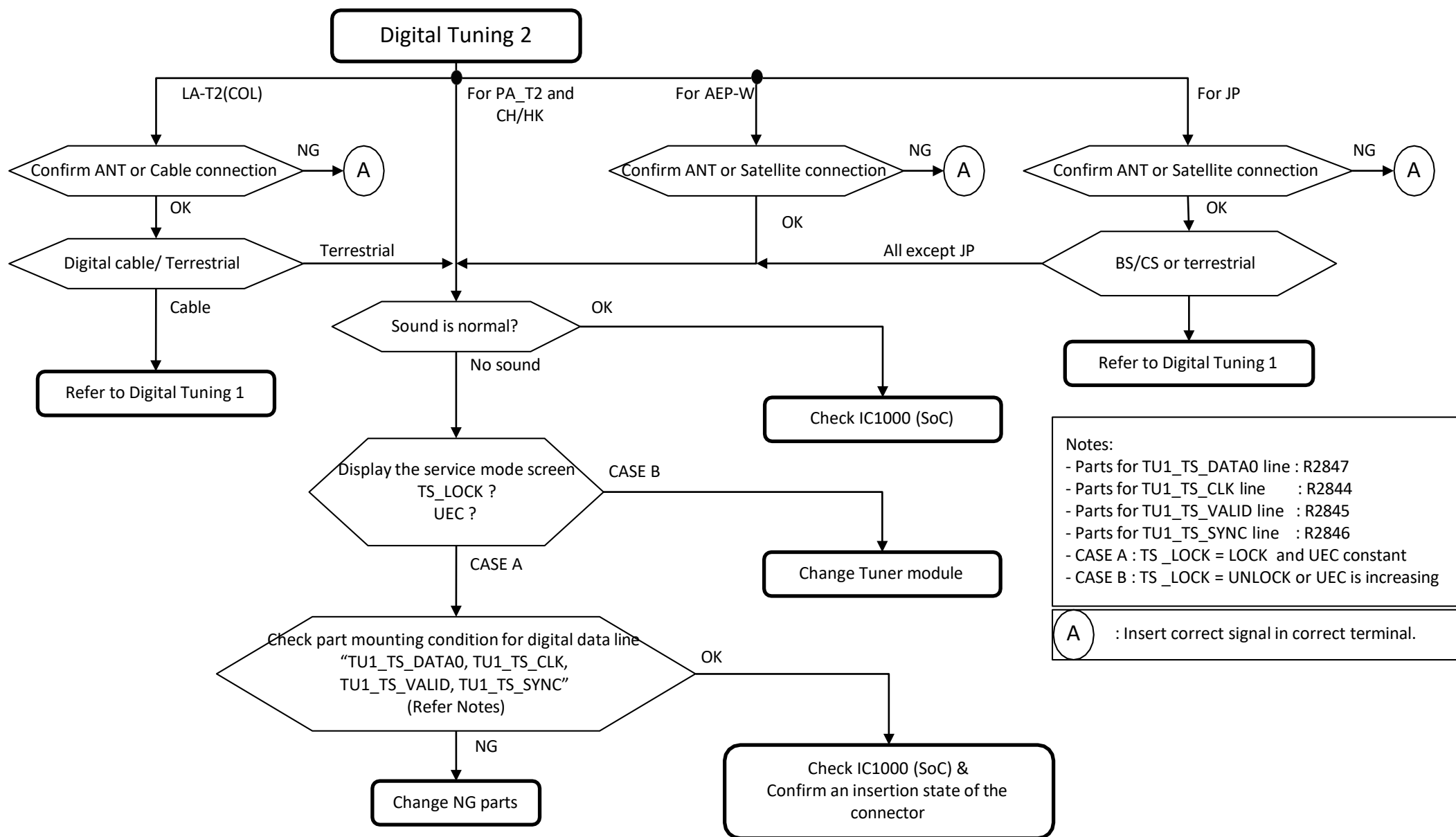

Notes:

- Parts for TU1_TS_DATA0 line : R2847
- Parts for TU1_TS_CLK line : R2844
- Parts for TU1_TS_VALID line : R2845
- Parts for TU1_TS_SYNC line : R2846
- CASE A : TS_LOCK = LOCK and UEC constant
- CASE B : TS_LOCK = UNLOCK or UEC is increasing

(A) : Insert correct signal in correct terminal.

4.4 No Picture Tuner

BCH(Top View) TS1 line

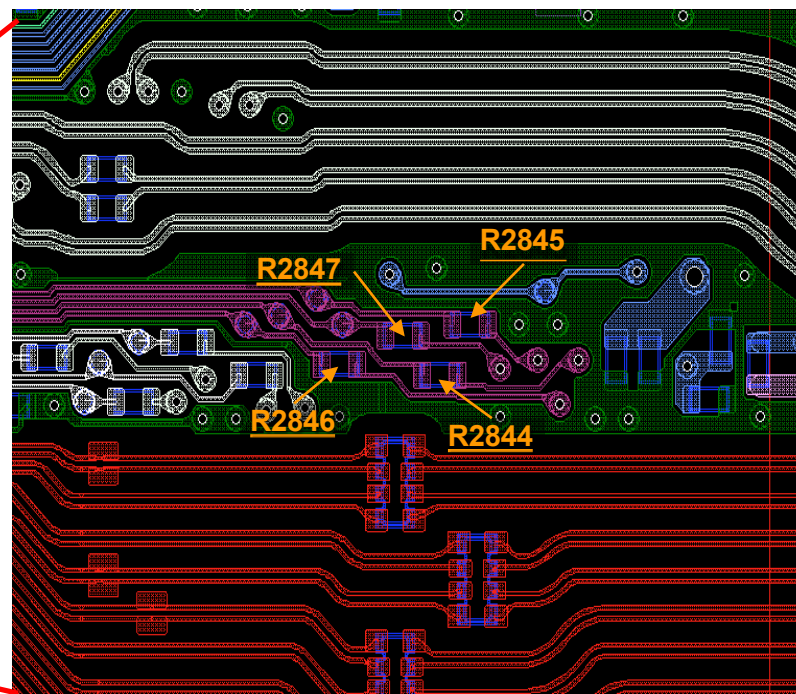
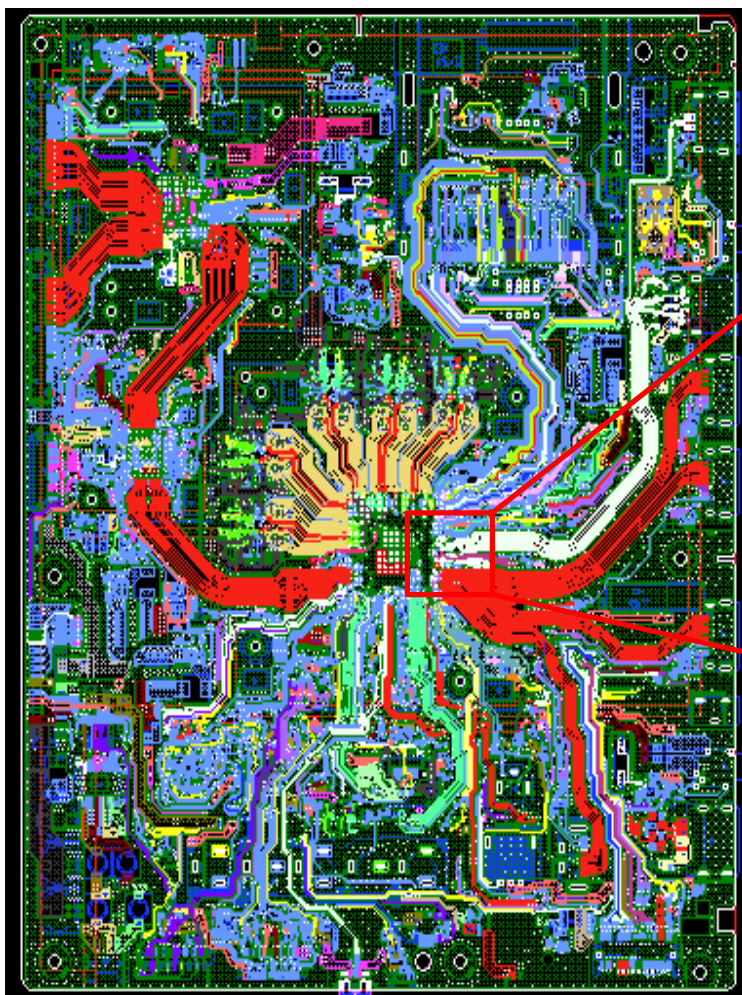

(Under the heatsink)

4.5 NO PICTURE HDMI

Checking condition:
 - TV ON & HDMI Source ON except if the flow mentioned is AC OFF.
 - TV HDMI input connected to HDMI source (Player etc.)
 - TV Input Selection: HDMI

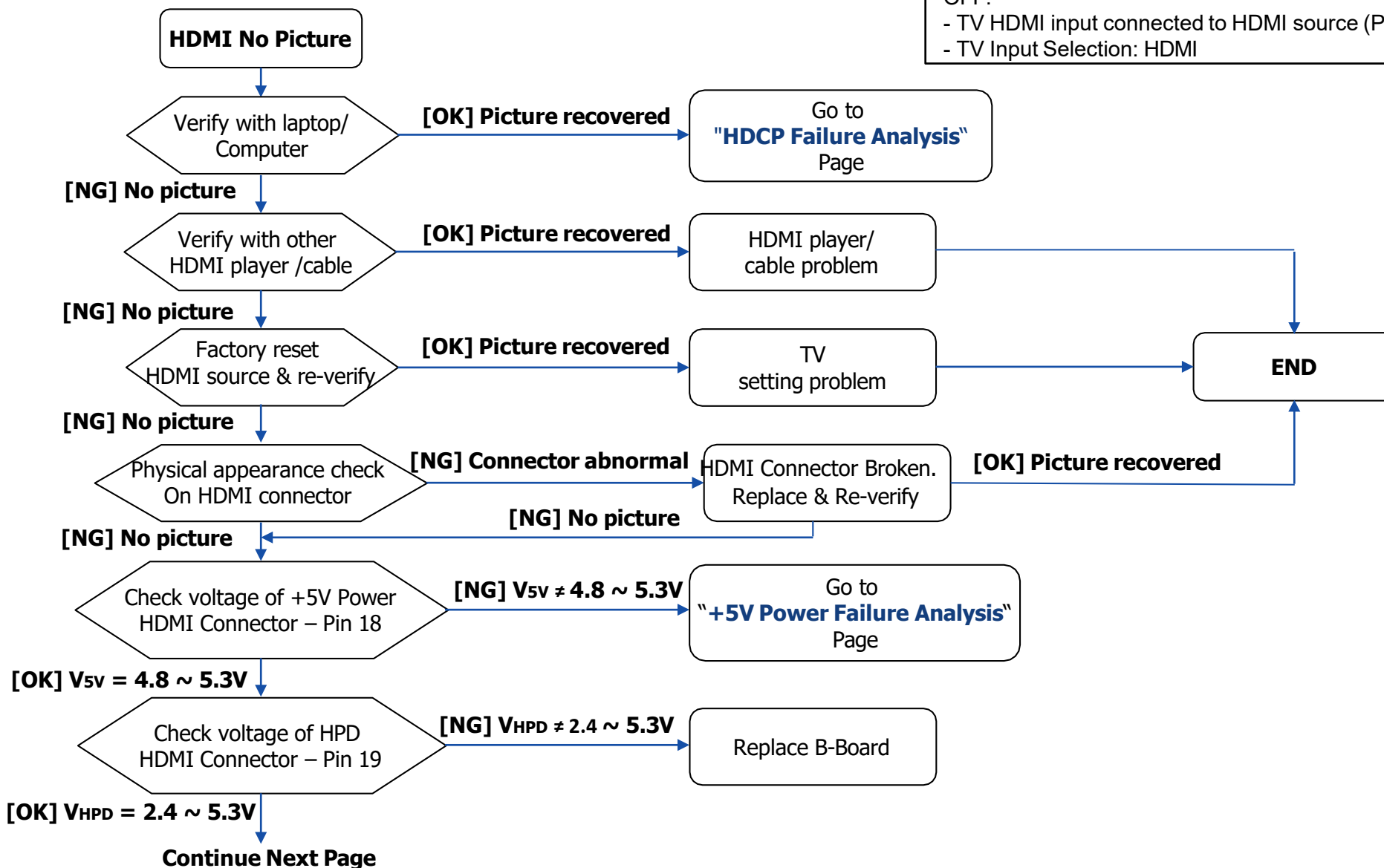

4.5 NO PICTURE HDMI

Checking condition:
 - TV ON & HDMI Source ON except if the flow mentioned is AC OFF.
 - TV HDMI input connected to HDMI source (Player etc.)
 - TV Input Selection: HDMI

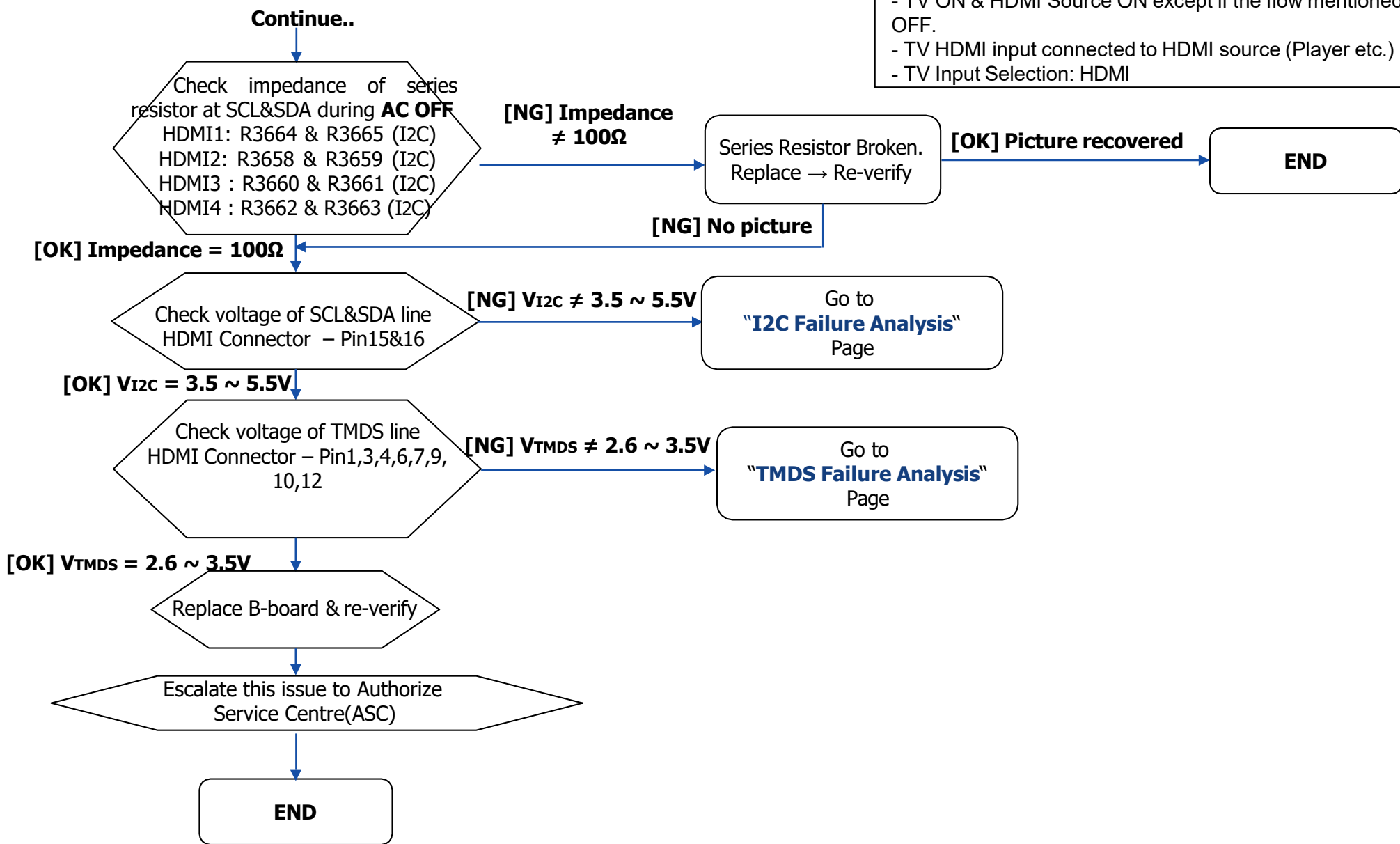

4.5 NO PICTURE HDMI

Checking condition:
 - TV ON & HDMI Source ON except if the flow mentioned is AC OFF.
 - TV HDMI input connected to HDMI source (Player etc.)
 - TV Input Selection: HDMI

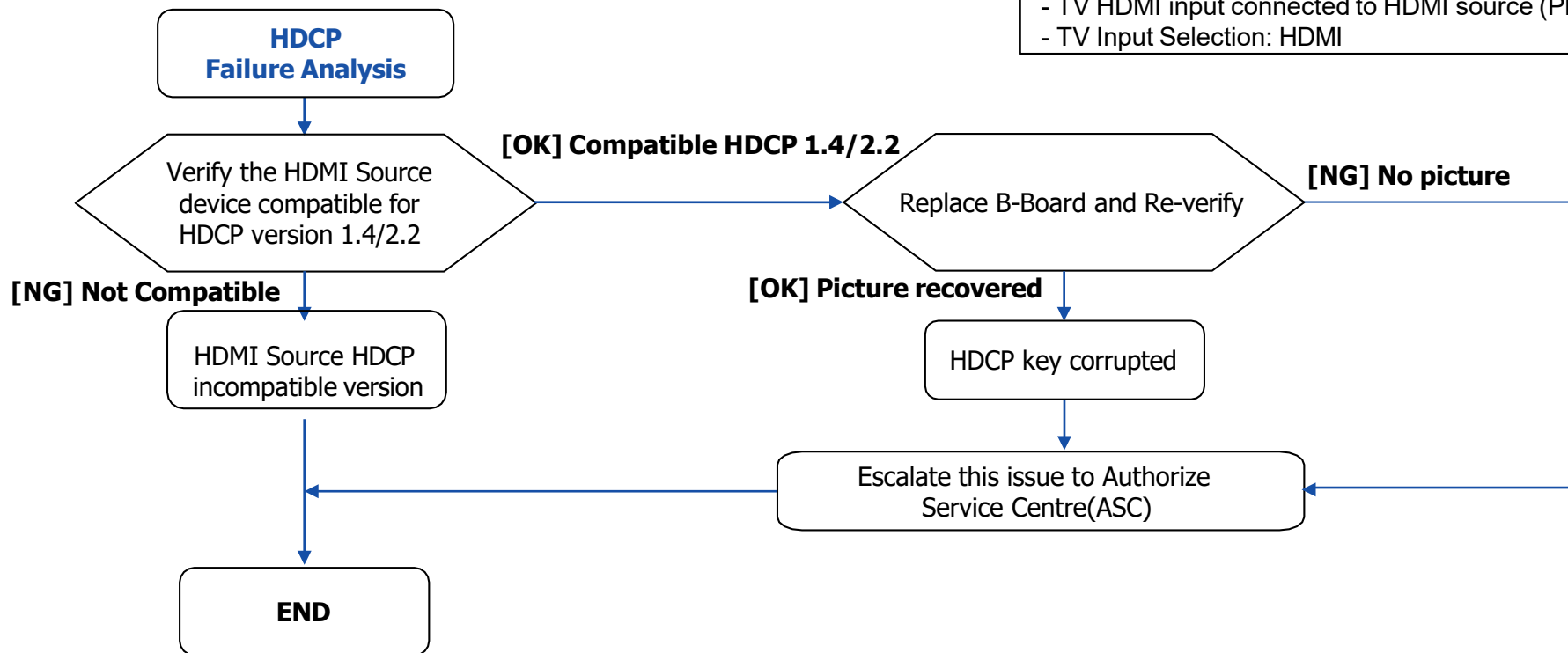

4.5 NO PICTURE HDMI

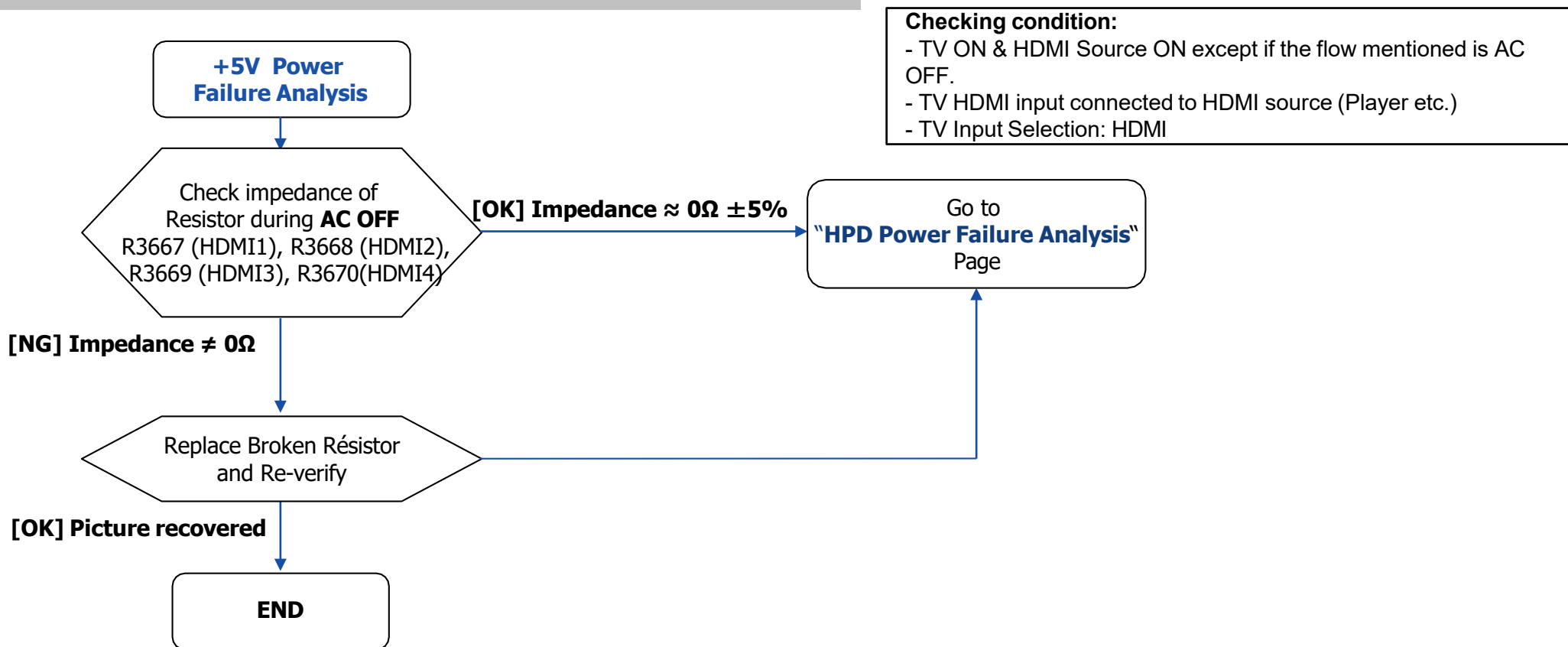

4.5 NO PICTURE HDMI

Checking condition:
 - TV ON & HDMI Source ON except if the flow mentioned is AC OFF.
 - TV HDMI input connected to HDMI source (Player etc.)
 - TV Input Selection: HDMI

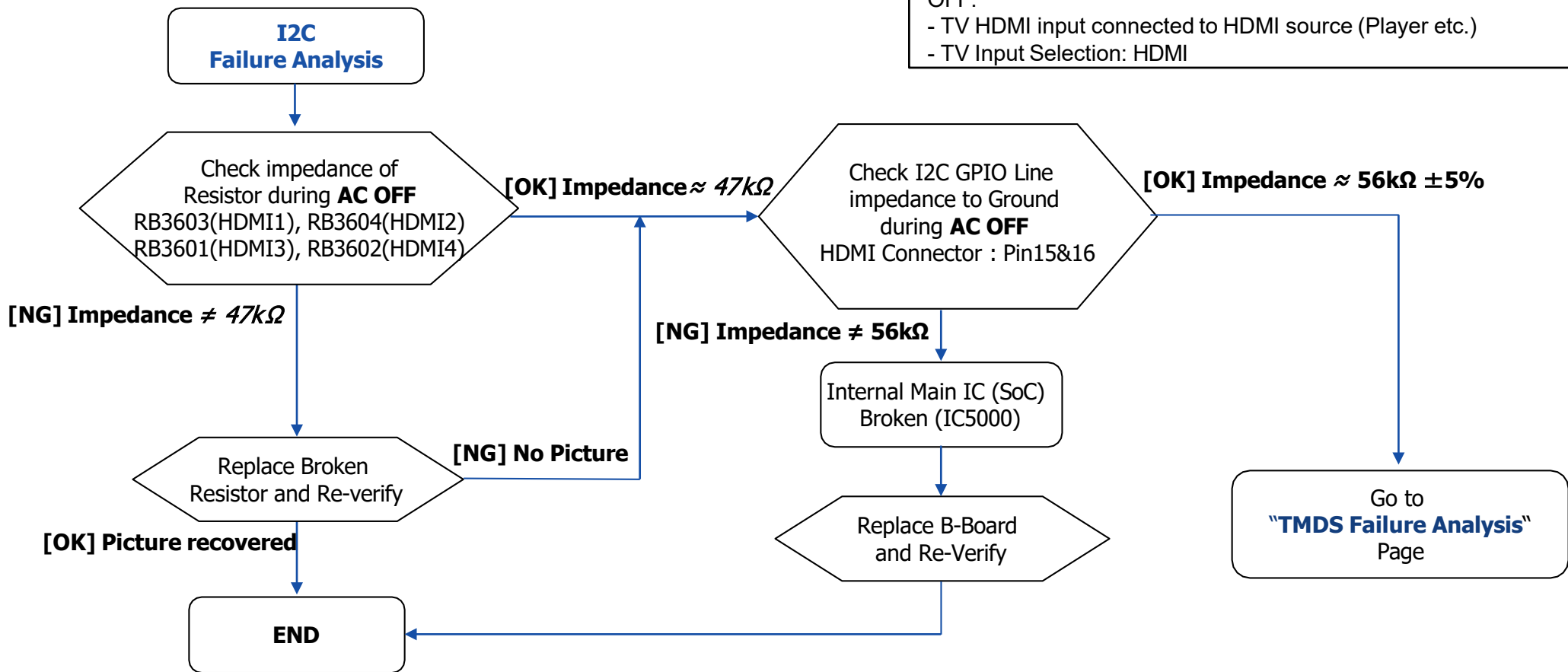

4.5 NO PICTURE HDMI

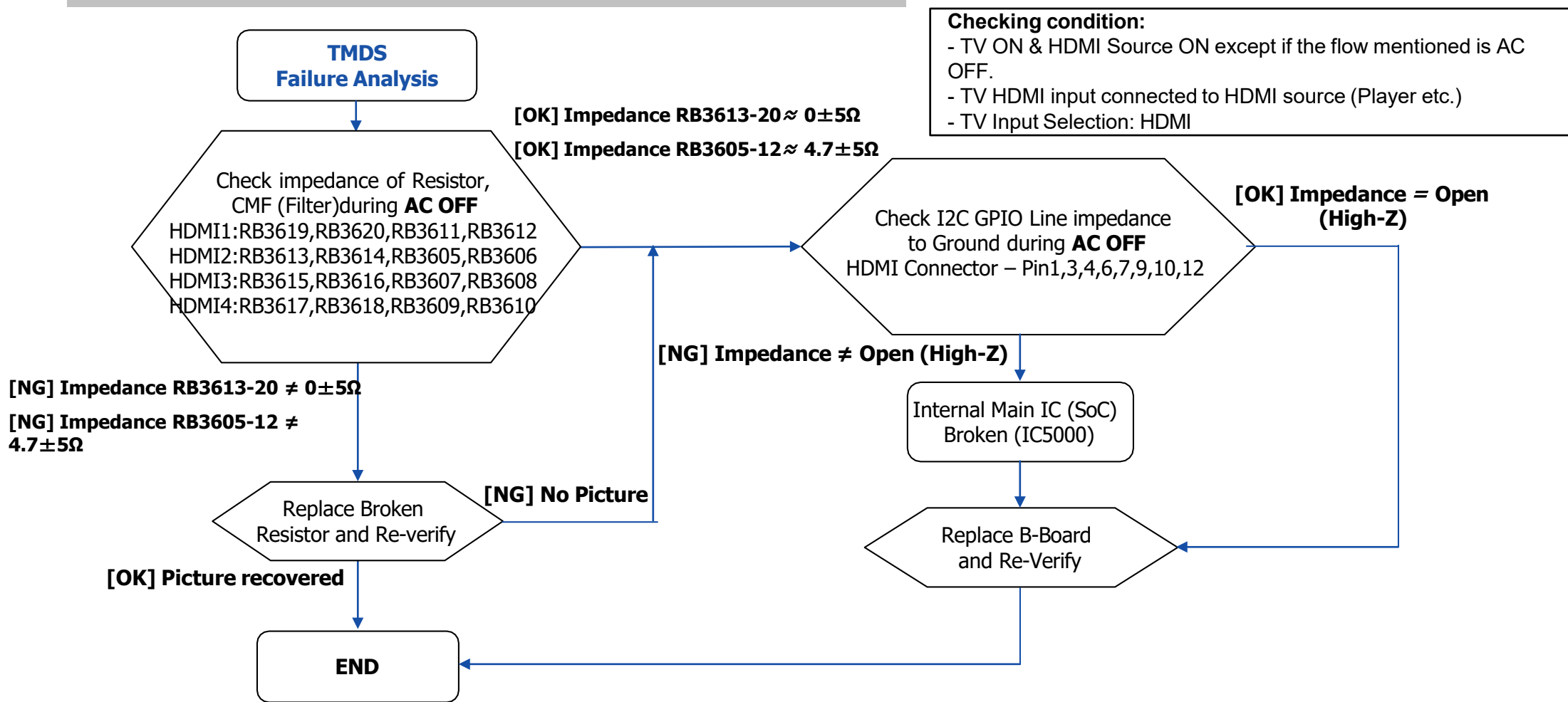

5.0 Key Switch Buttons Error

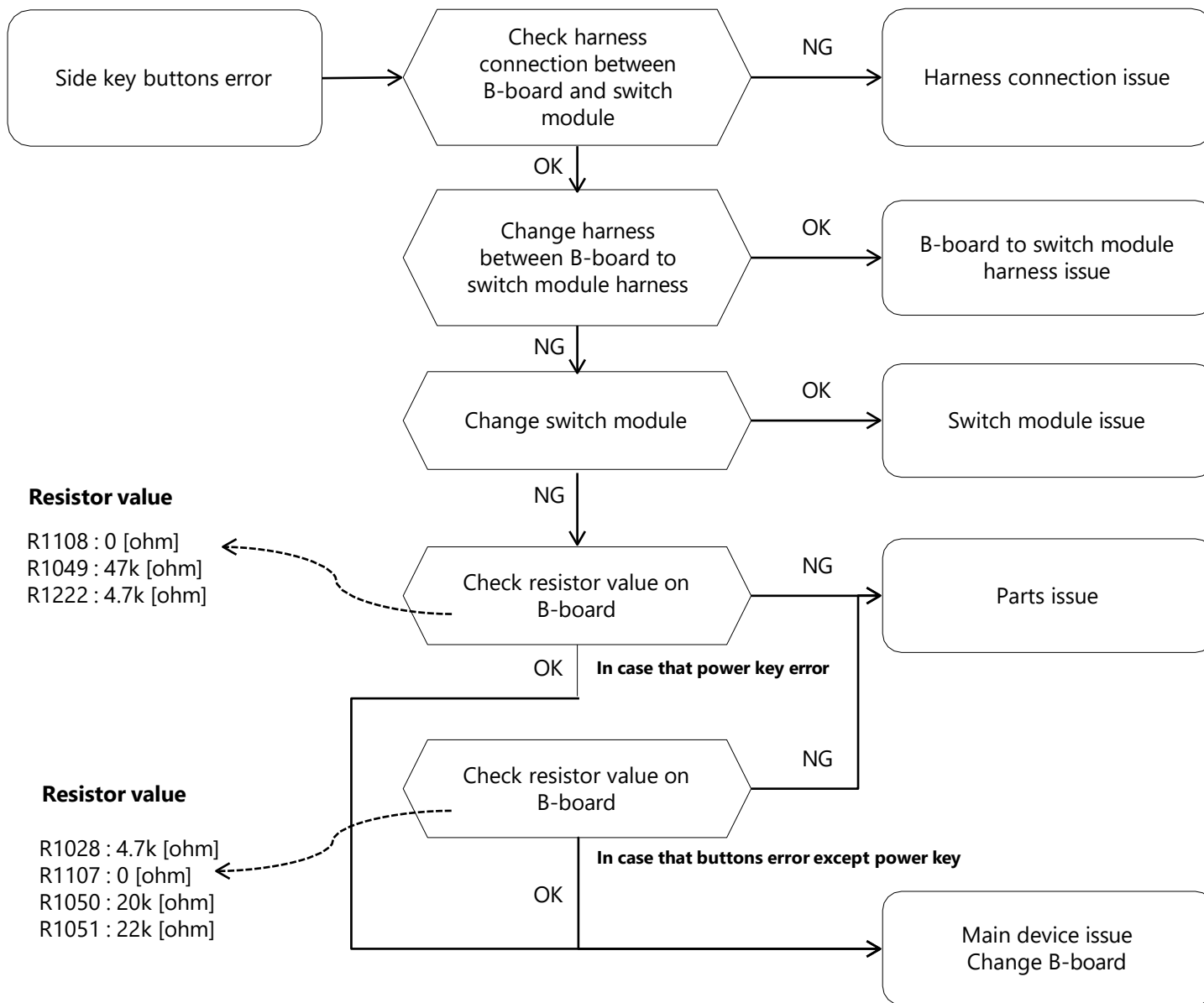

5.1 IR Remote Commander Error

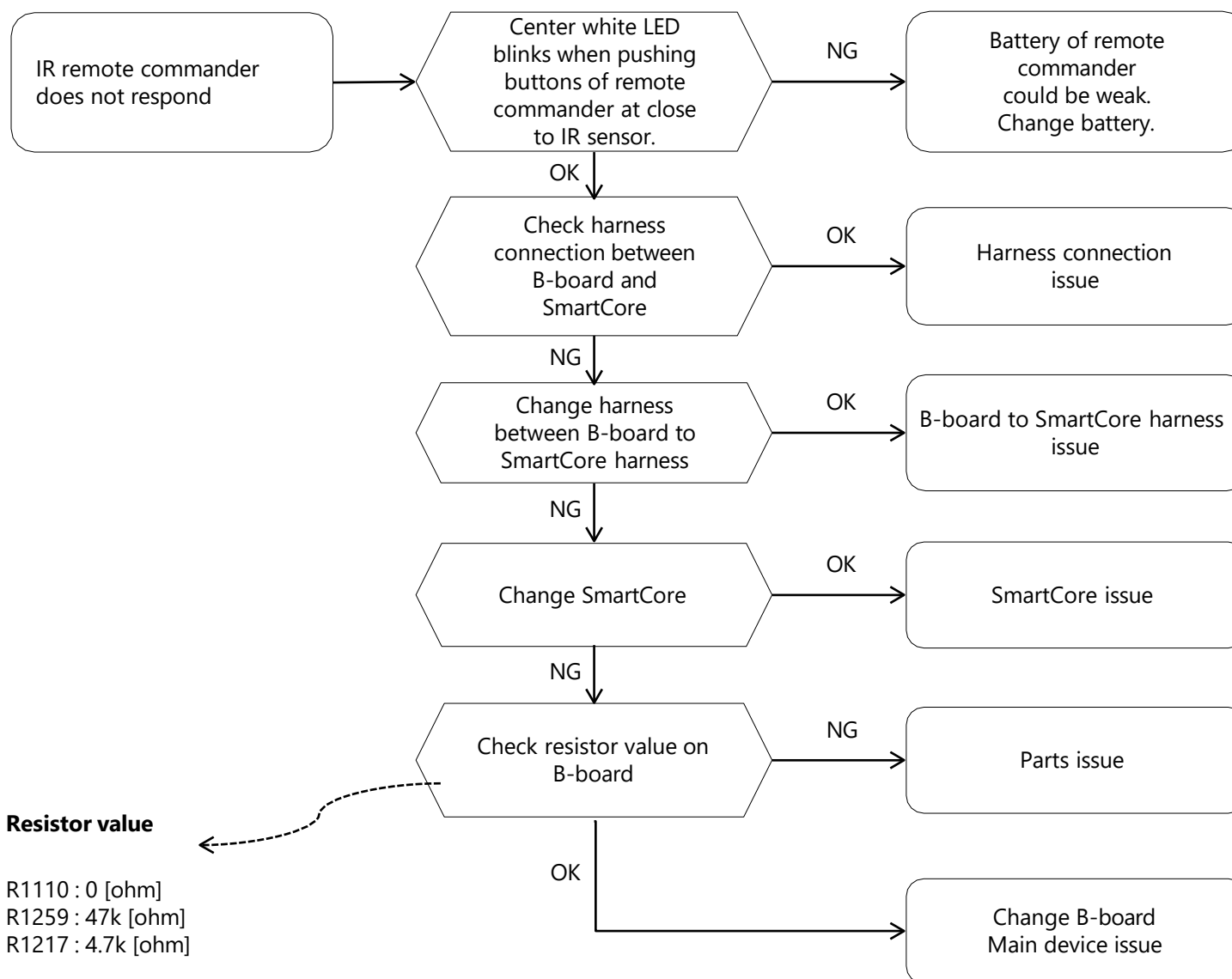

5.2 Light Sensor Error

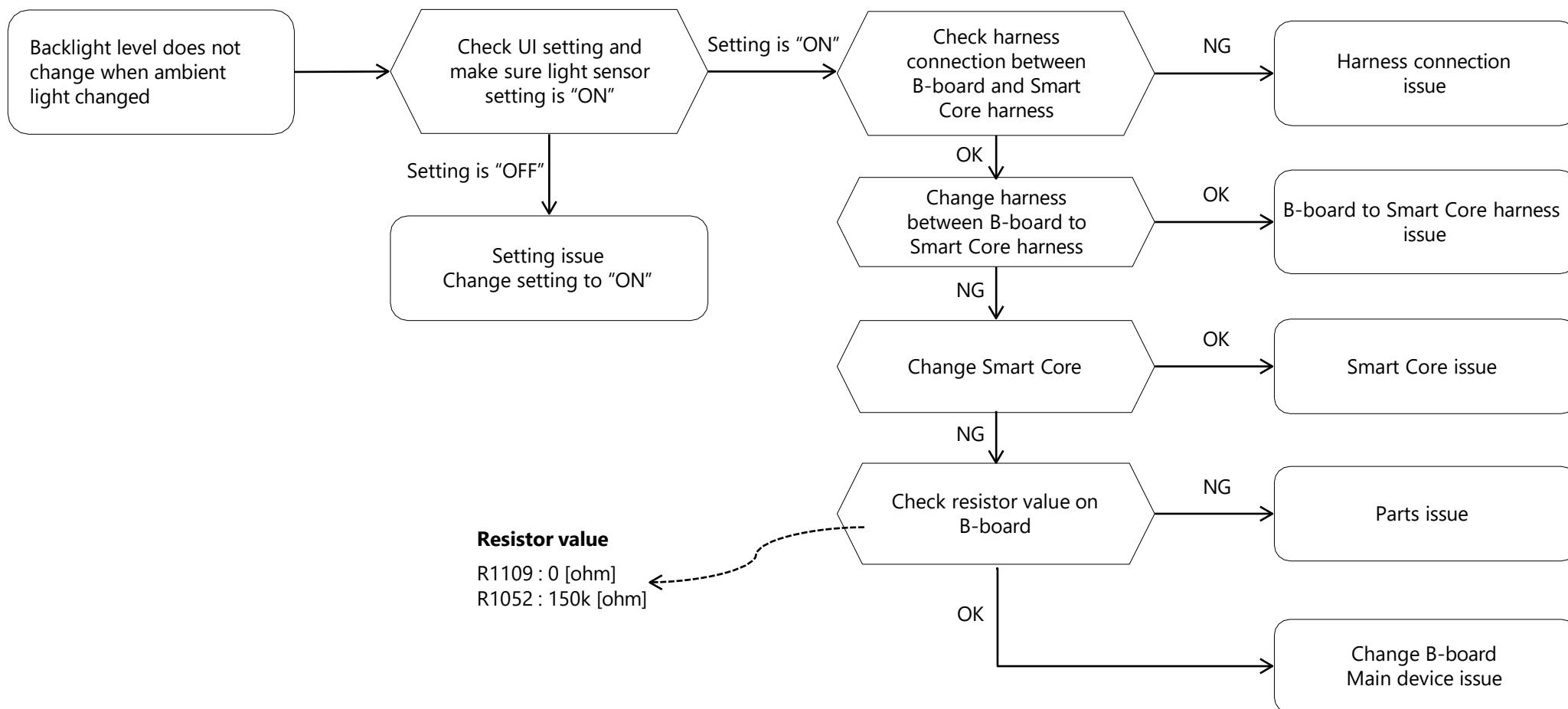

6.0 Network Malfunction: Ethernet (Wired)

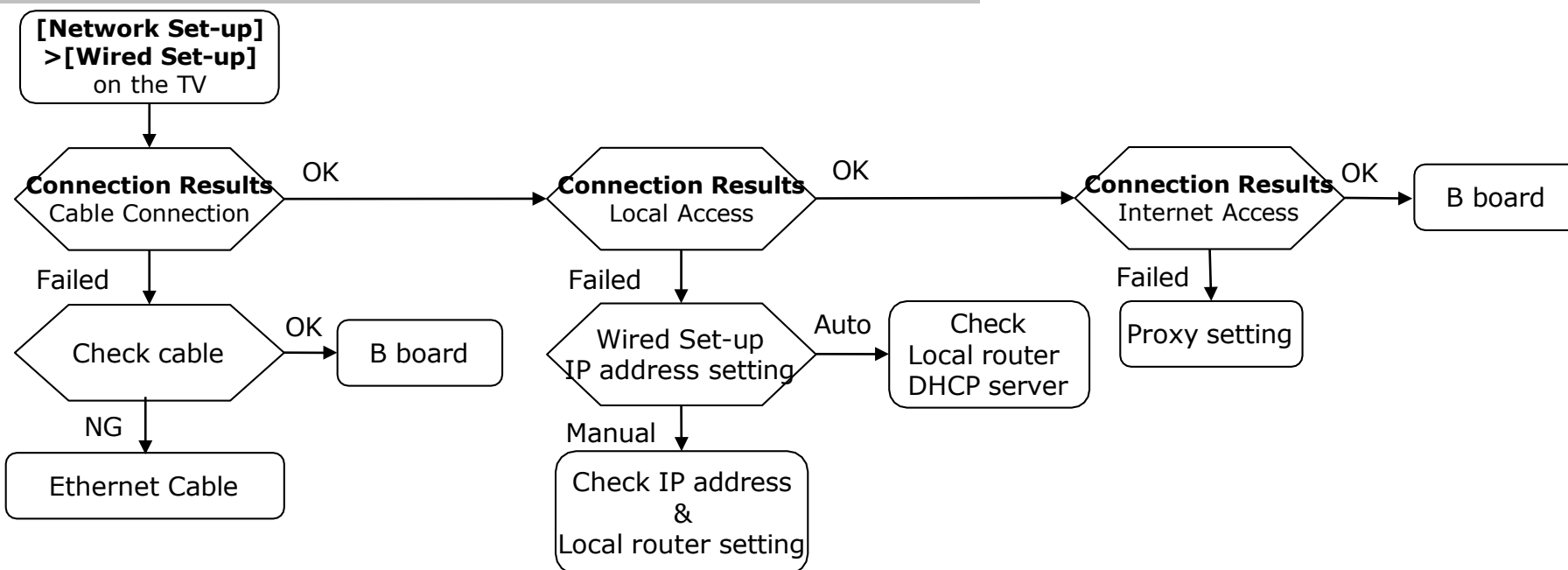

B Board

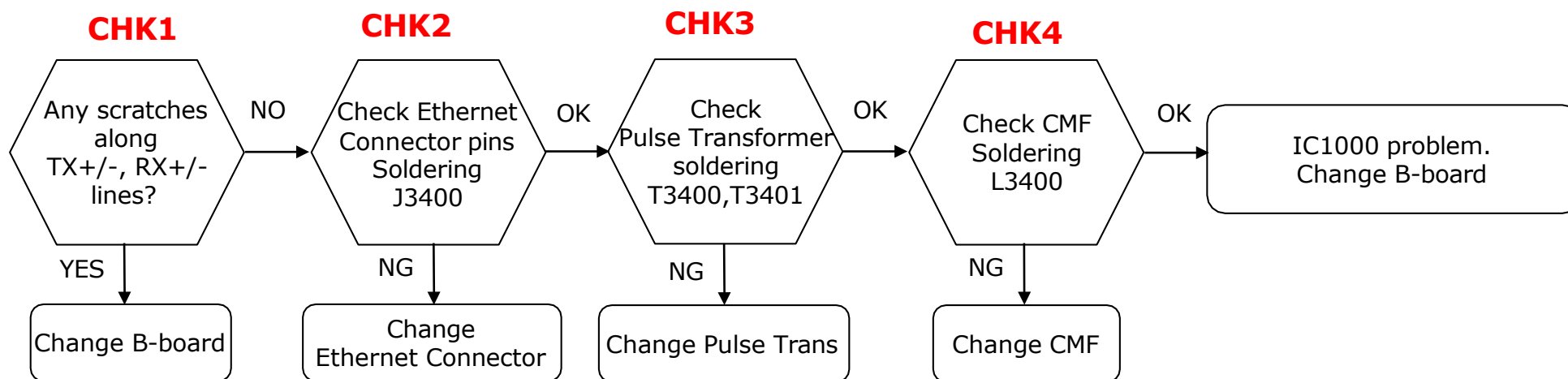

6.0 Network Malfunction: Ethernet (Wired)

Check point for BCH

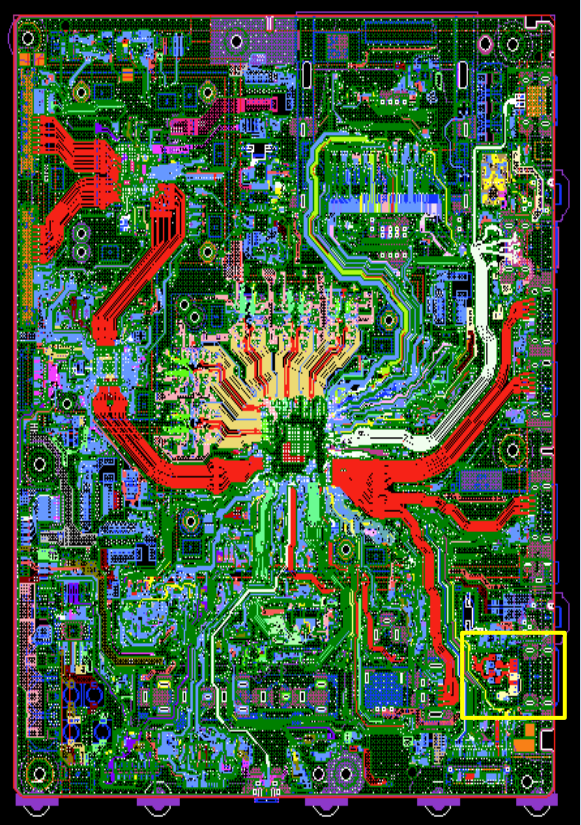
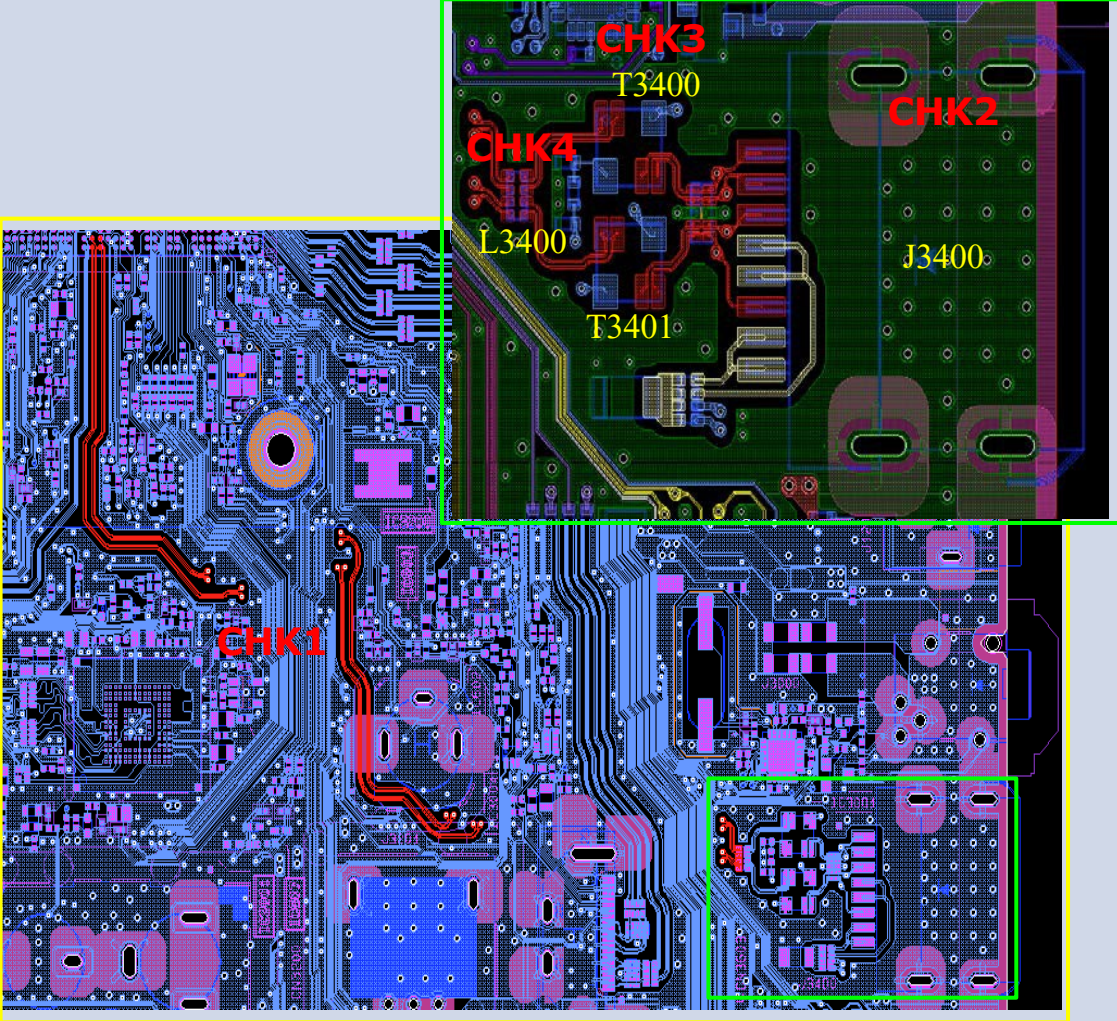
Name	Board PWB (A side)	Detail
BCH		

6.2 Wireless Network malfunction

1) Internal Wireless Network malfunction

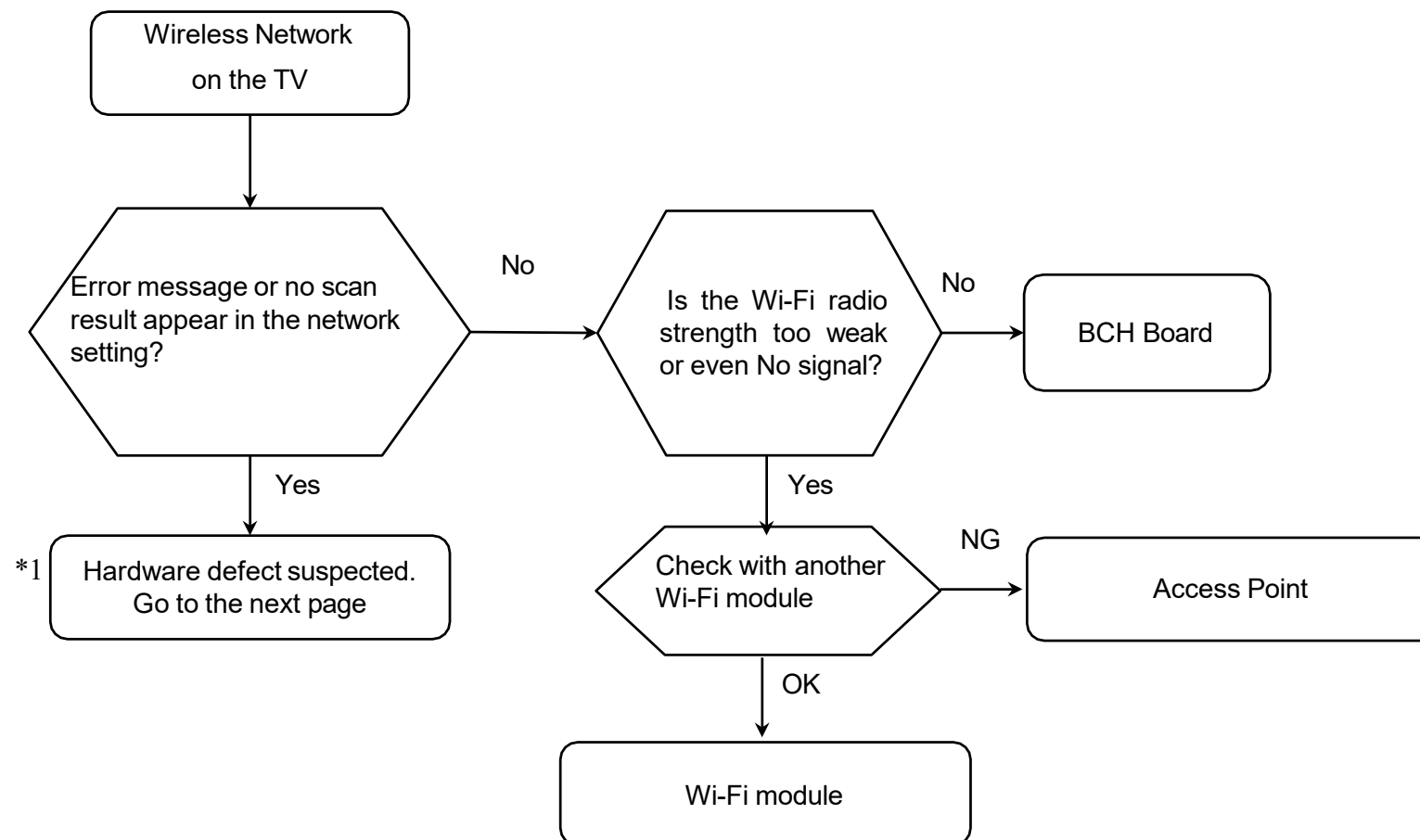

6.2 Wireless Network malfunction

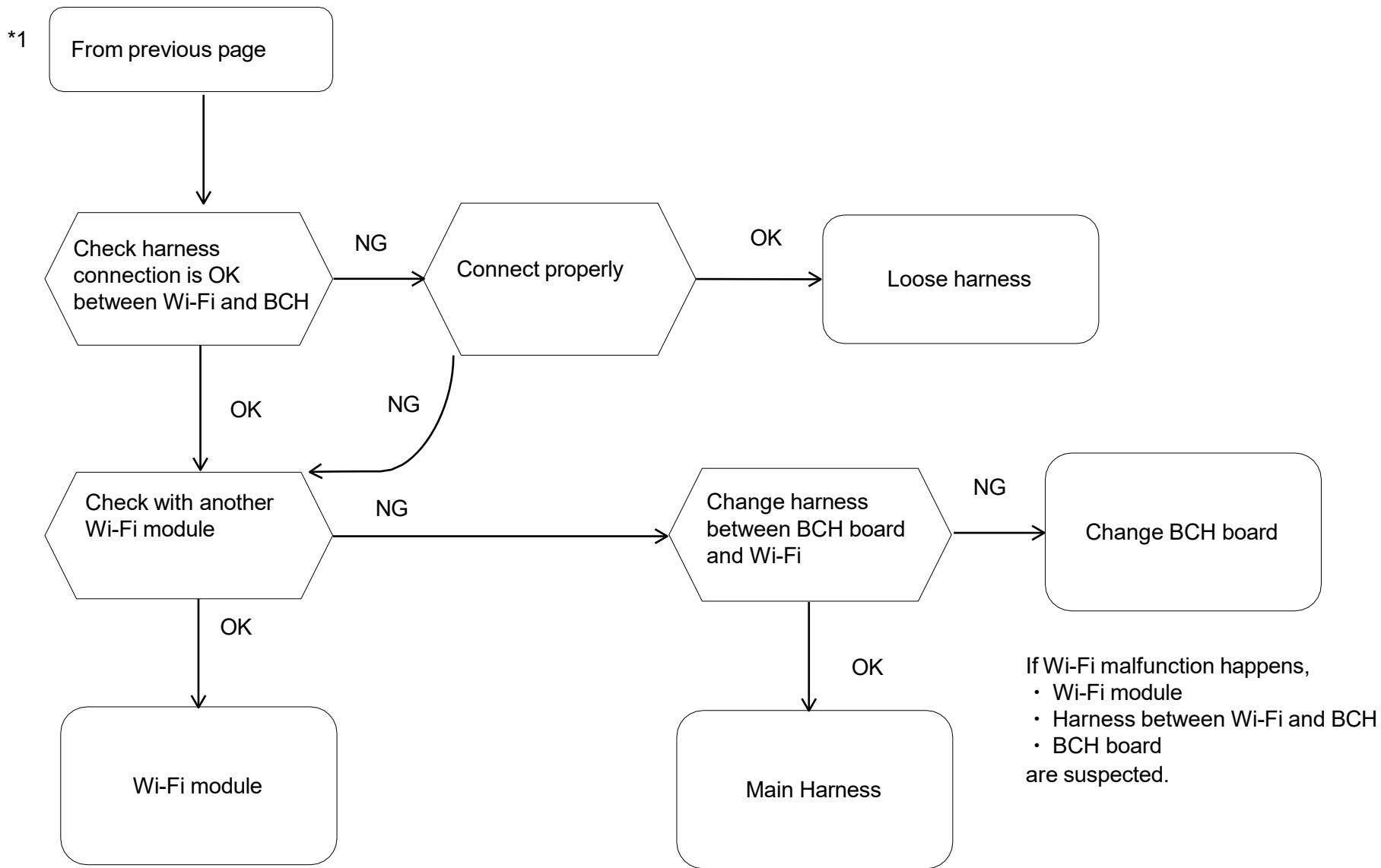

6.3 Bluetooth malfunction

Bluetooth Speaker is supported and 3D-glasses is not supported from FY17

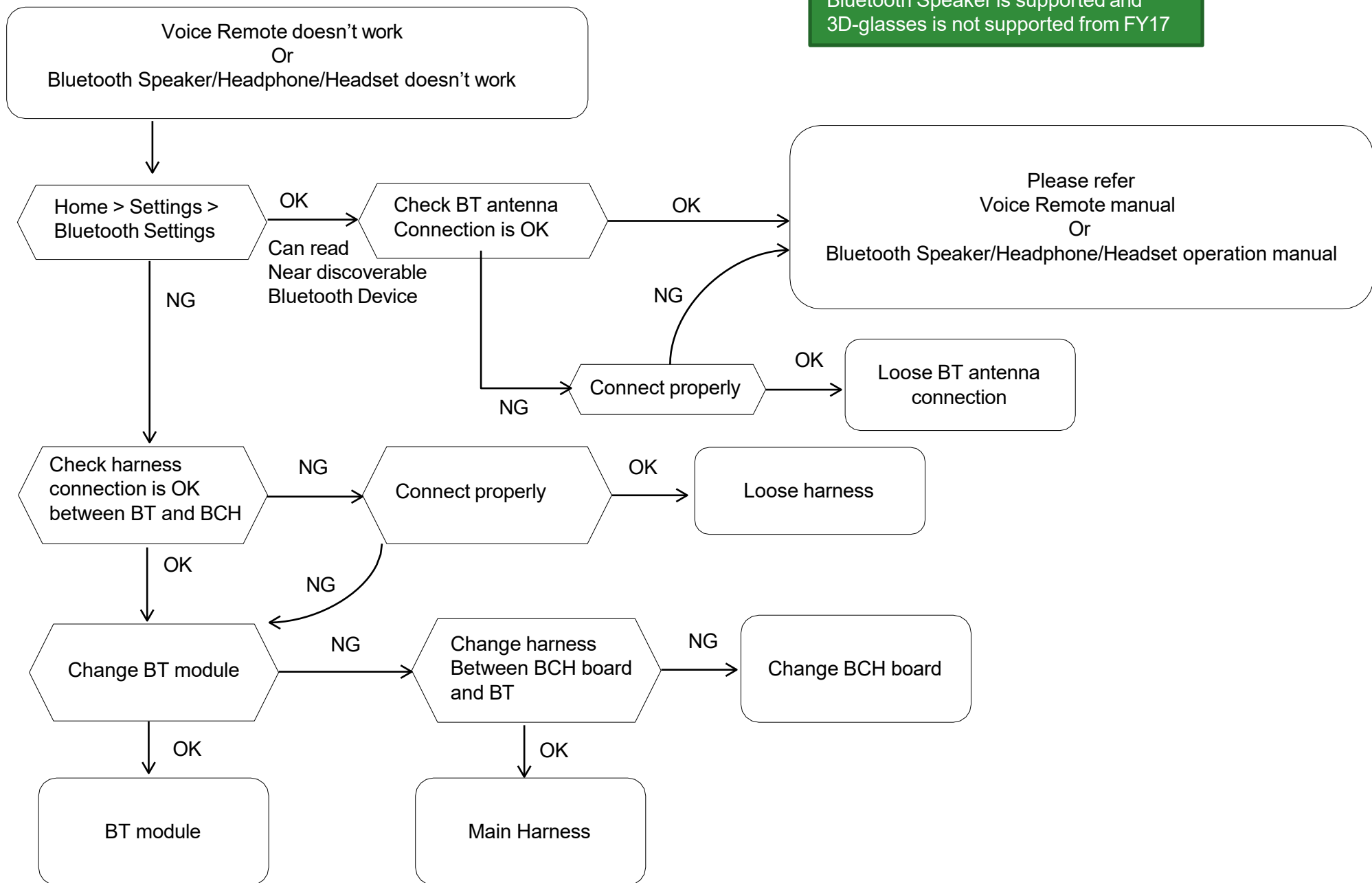

4.2 Connector Diagram

43' inch

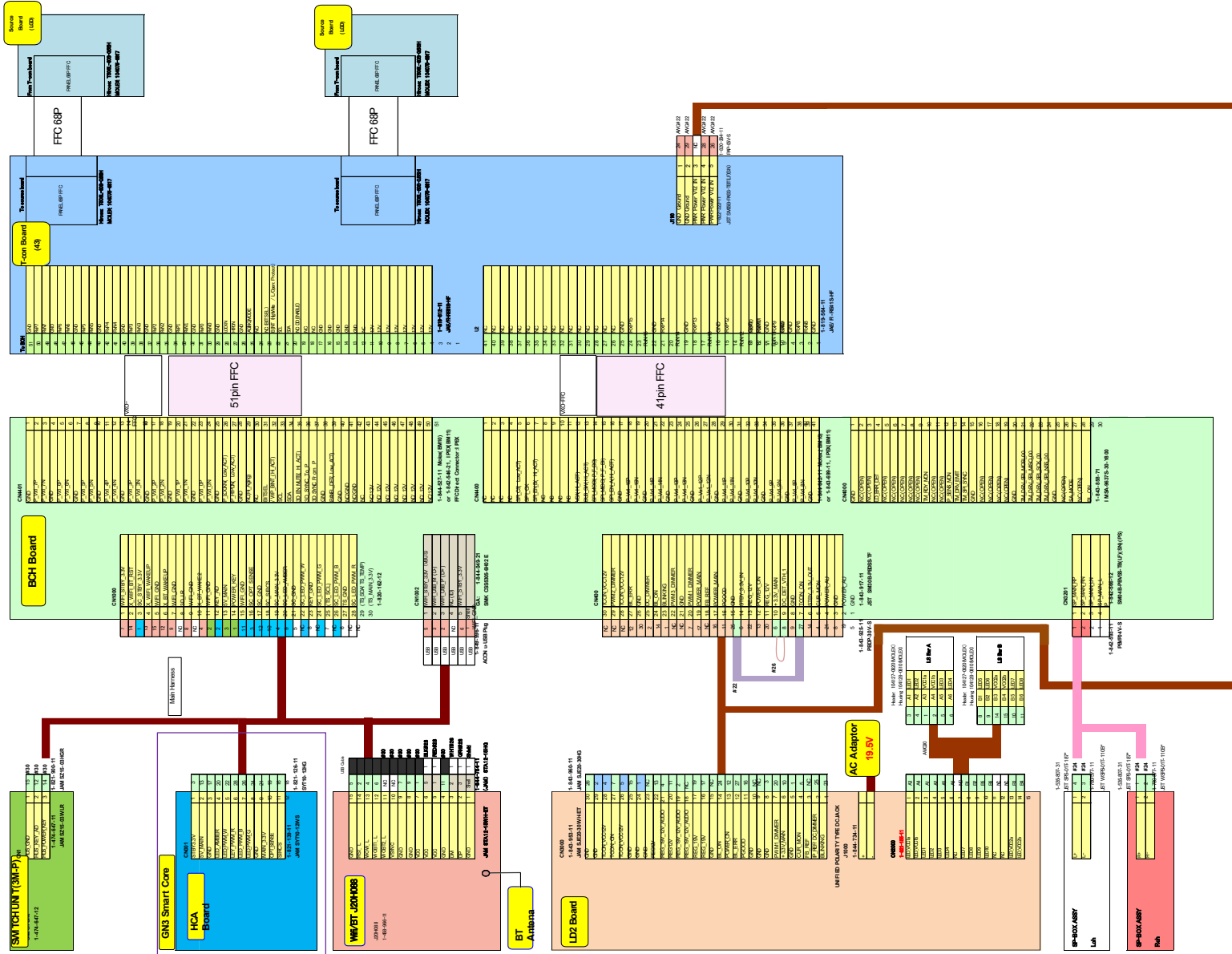

49' inch

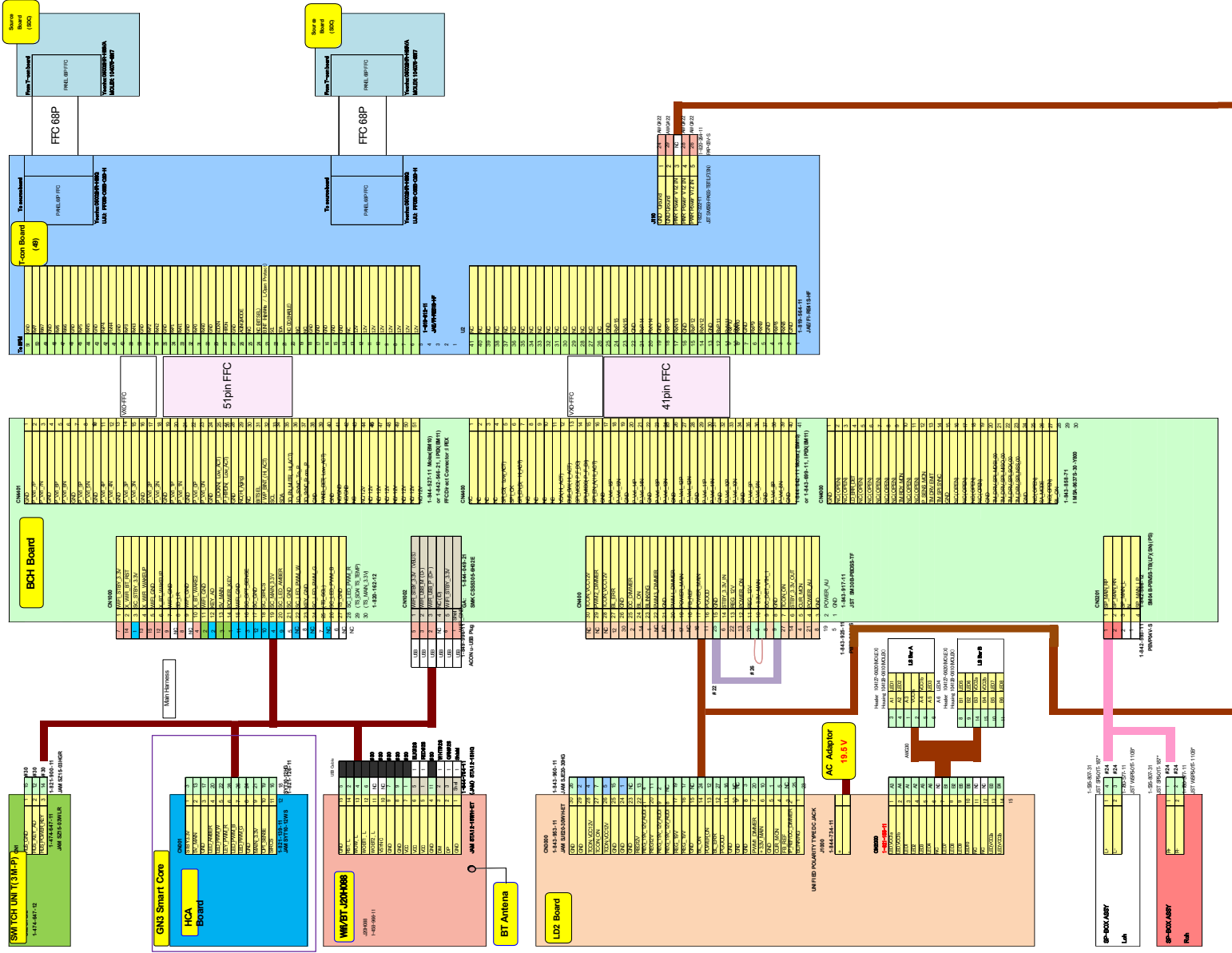



SERVICE MANUAL (DIASSEMBLY)

ORIGINAL MANUAL ISSUE DATE: 2023/11

DISCLAIMER: USE AT OWN RISK. SONY AND ITS AFFILIATES ARE NOT LIABLE FOR ANY DAMAGE OR INJURY CAUSED TO ANY DIGITAL ELECTRONIC EQUIPMENT, PERSON, OR PROPERTY, WHICH OCCURS DUE TO USE OF THE TOOLS, PARTS, DOCUMENTATION, OR OTHER MATERIALS HEREIN PROVIDED, WHETHER FOR REPAIR, DIAGNOSIS, MAINTENANCE, MODIFICATION, OR OTHERWISE, INCLUDING BUT NOT LIMITED TO: ANY INDIRECT, INCIDENTAL, SPECIAL, OR CONSEQUENTIAL DAMAGES; ANY LOSS OF DATA, PRIVACY OR PROFITS; OR ANY INABILITY TO USE, OR REDUCED FUNCTIONALITY OF, THE DIGITAL ELECTRONIC EQUIPMENT.

The manual is intended for a trained professional and the use of the manual is at your own risk.

9-888-744-U1

LCD TV

SONY®

Sony EMCS (Malaysia) Sdn. Bhd. HES-M

© 2023.11

MODEL LIST

<u>MODEL</u>	<u>REMOTE</u>	<u>DESTINATION</u>
FW-43BZ35F	RMT-TB400U	UC2
FW-49BZ35F	RMT-TB400U	UC2

TABLE OF CONTENTS

<u>Section Title</u>	<u>Page</u>
1. SAFETY NOTES	
1-1. How to Remove Rear Cover.....	4
2. DIAGRAMS	
2-1. Circuit Board Location.....	11
2-2. Wire Dressing	13
3. EXPLODED VIEWS AND PARTS List	
3-1. FW-43BZ35F.....	44
3-2. FW-49BZ35F.....	50
3-3. Smart Core.....	56

Please refer Service Manual (Troubleshooting) for below information:

- General Safety Notes
- Self Diagnostic Function
- Triage Chart
- Troubleshooting, Troubleshooting reference
- Diagram: Connector Diagram

Note: Pictures provided in all this manual might have slight difference from the actual sets

SECTION 1 DISASSEMBLY AND REMOVAL CAUTION

Rear Cover Disassemble Method & Caution Notes 43"/49"

Rear Cover disassembly procedure

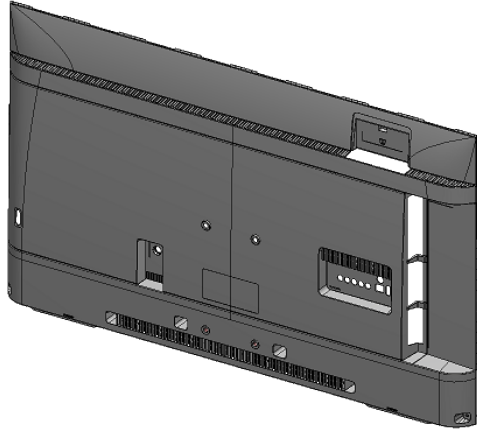

Cover Card disassemble guide (before removing rear cover (RC)) **※EU/JP only**

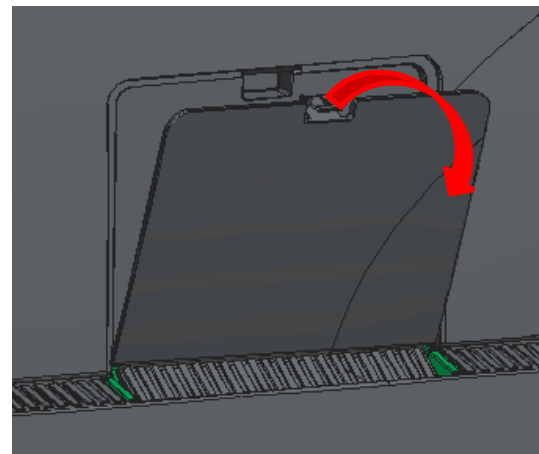
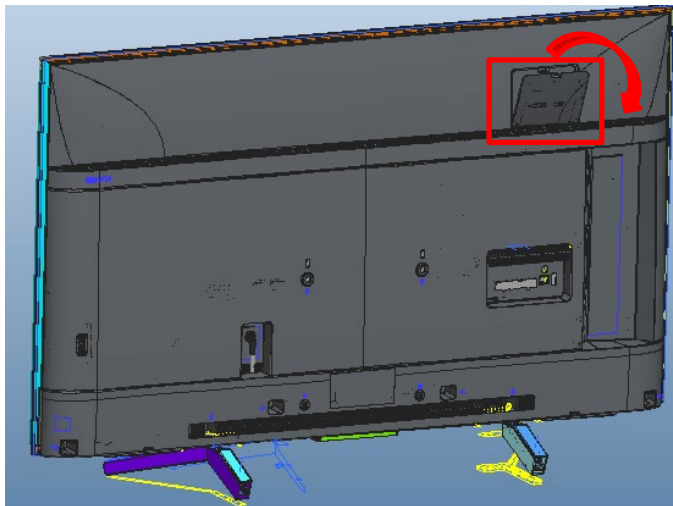

Pull out Cover Card

※ After repairing process complete, please insert back Cover Card

3. Pull up at Screw area on Rear Cover and unhook on Rear Cover.

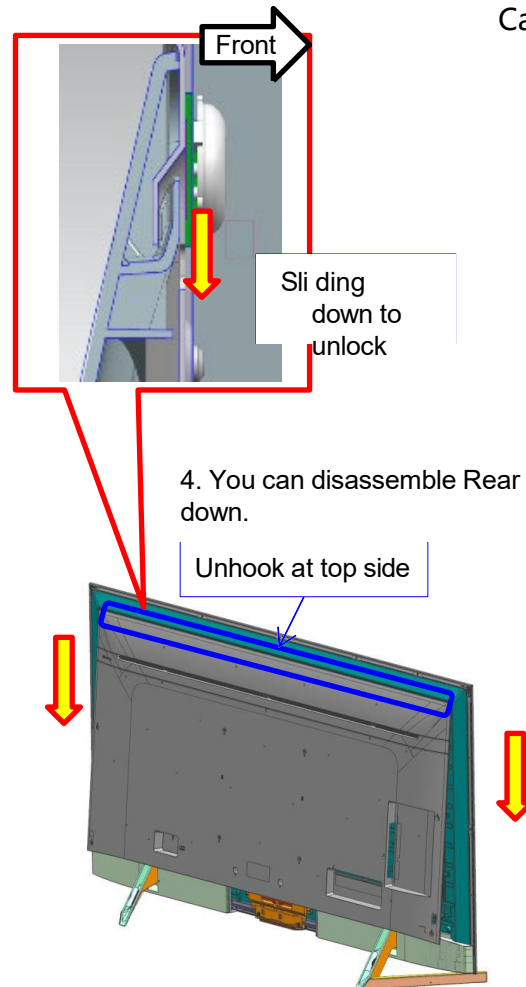
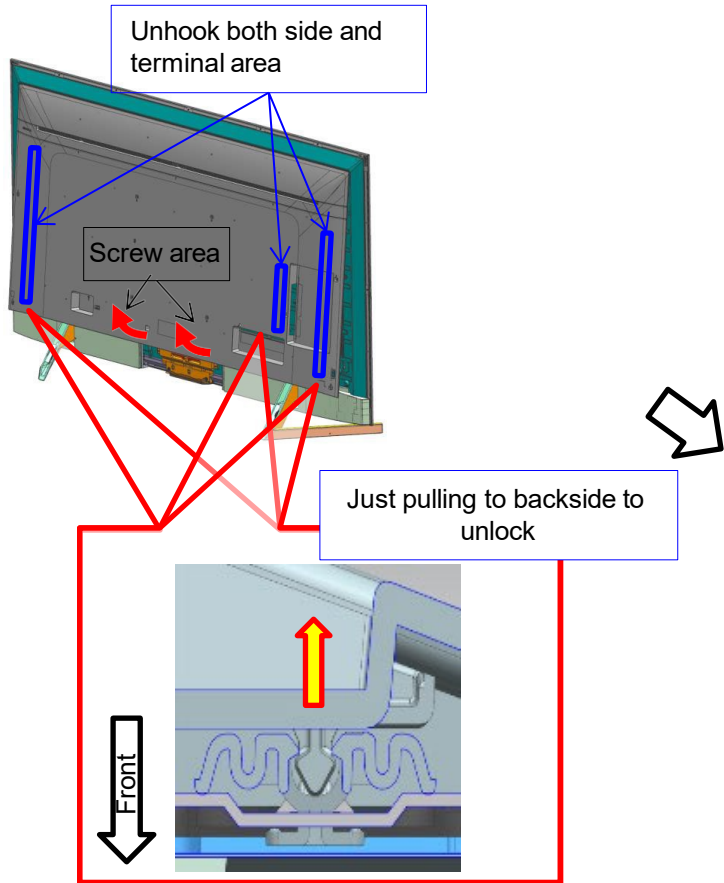

Catcher Position of side terminal

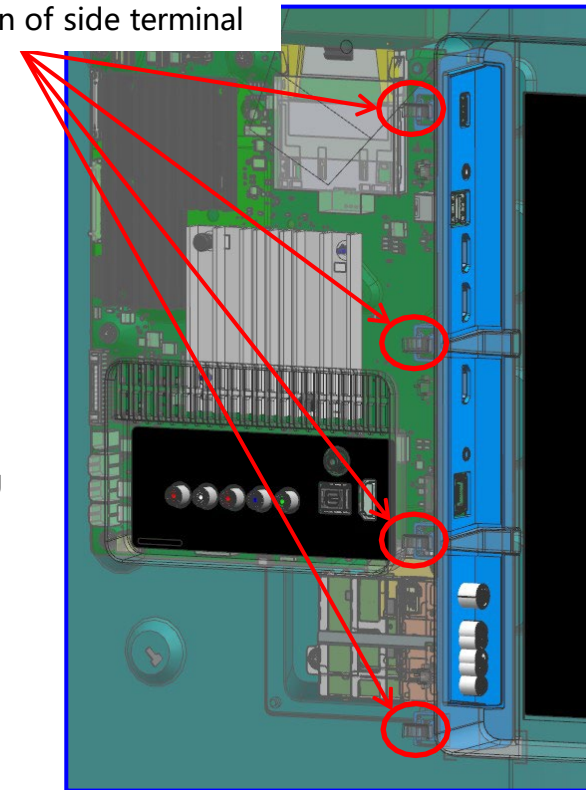

Remove screw

43"/49"

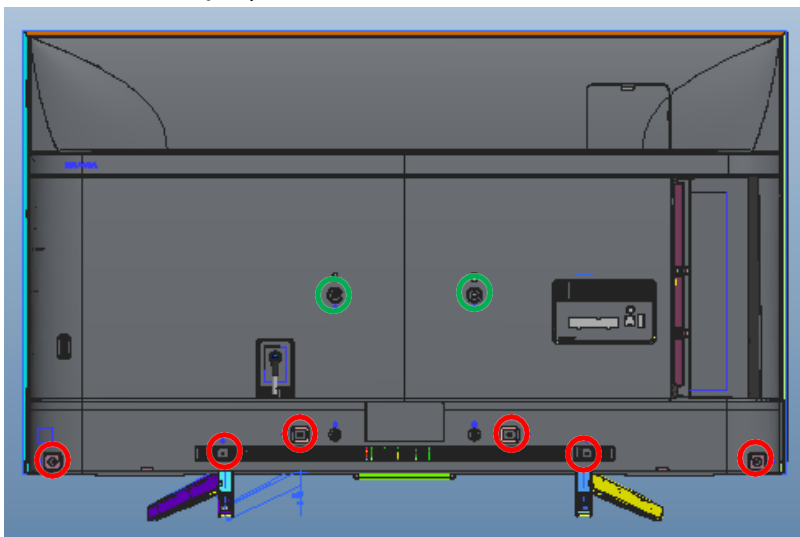

Step 1) Ensure all screws is removed

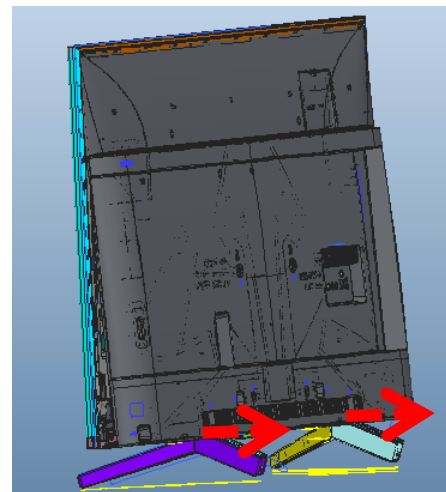

Step 2) Take out Rear Cover.



Screw type and quantity to disassemble Rear Cover

Reference	43	49	Remarks
	6	6	4-167-019-22 SCREW, +PSW M3X8
	2	2	4-268-126-02 SCREW, ORNAMENTAL M6X12

※ RC can be disassembled without detach stand

Rear Cover disassemble

- ① Pull Rear Cover bottom area until back of SP. and confirm release catcher
- ② Slide up Rear Cover (release top hook)

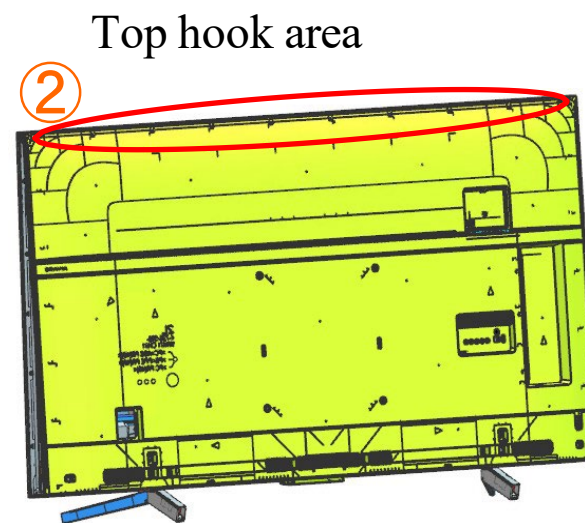
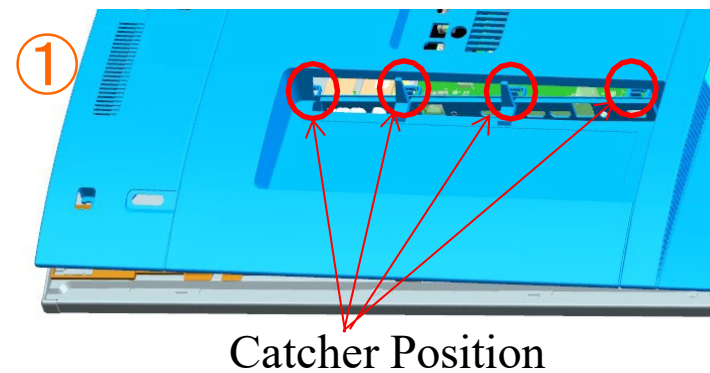
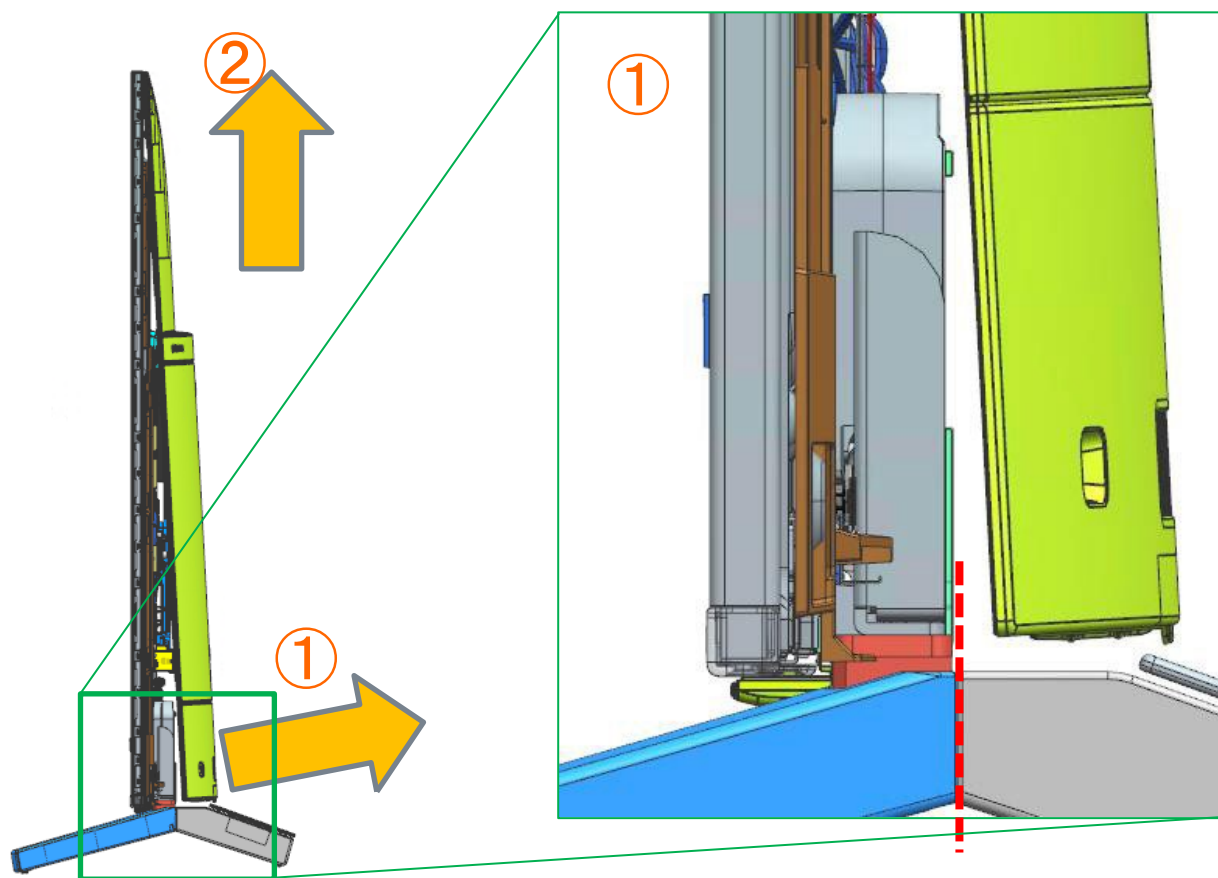

Sharp Edge Information

43"/49"

Caution point:

Please wear glove while removing rear cover to avoid sharp edge at bottom area and hook area as shown in figure below.

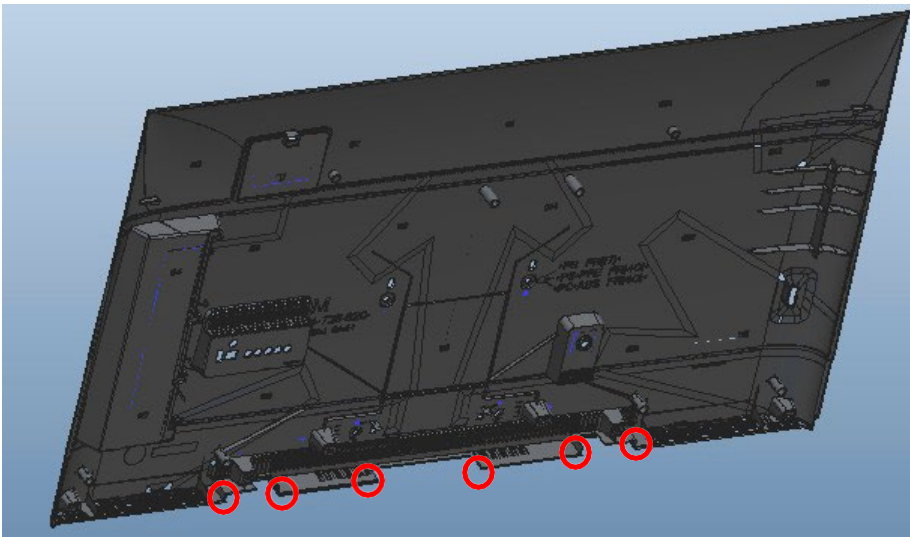

 Sharp edge area

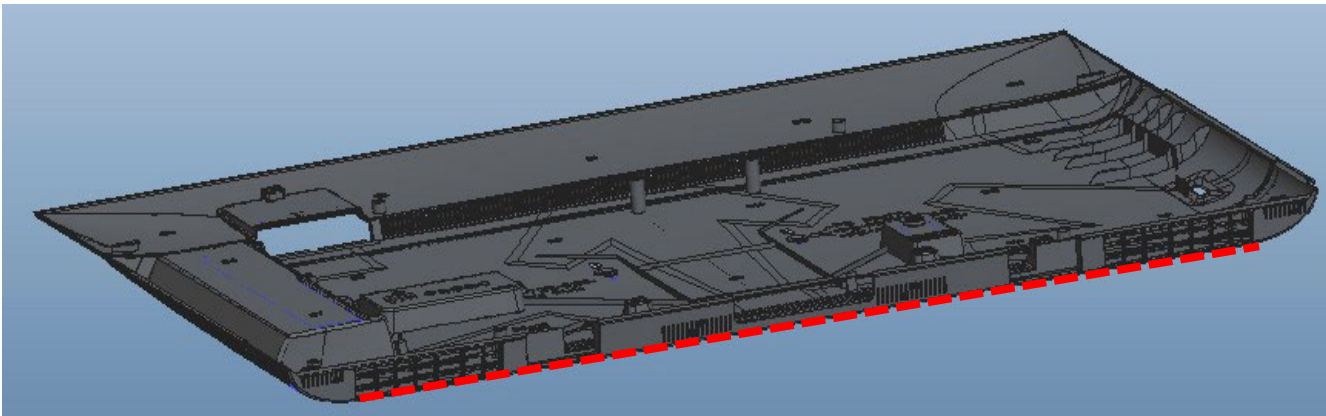

 Sharp edge area

Disassemble Smart Core from Set



1. Remove screw in red box

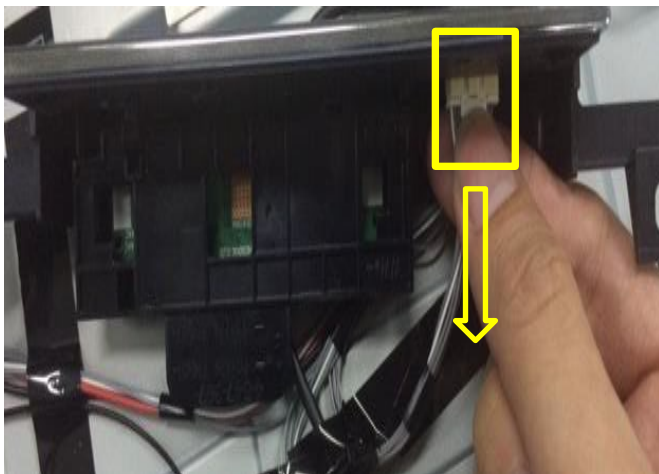

2. Remove harness



FRONT
VIEW



BACK
VIEW

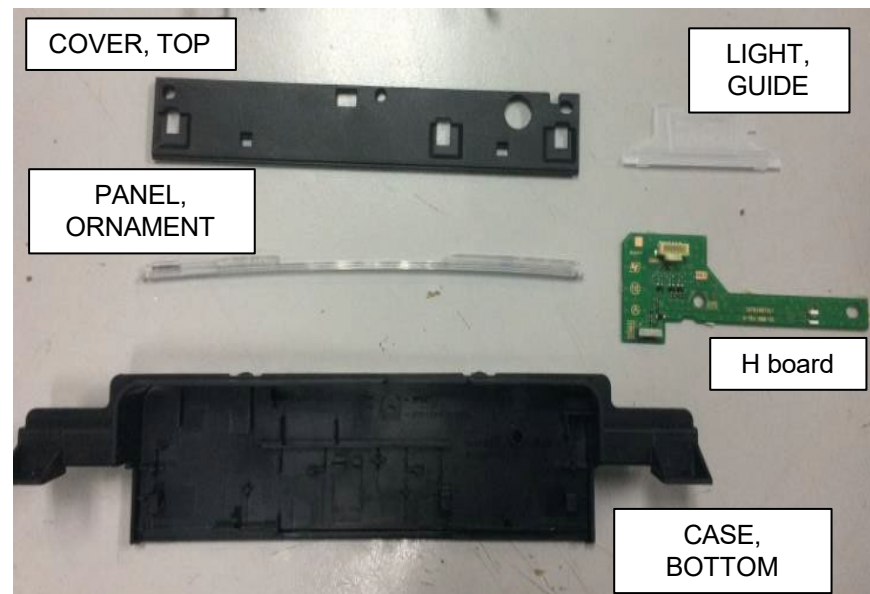

Disassemble Cover Top

Pull up the cover top by the following order

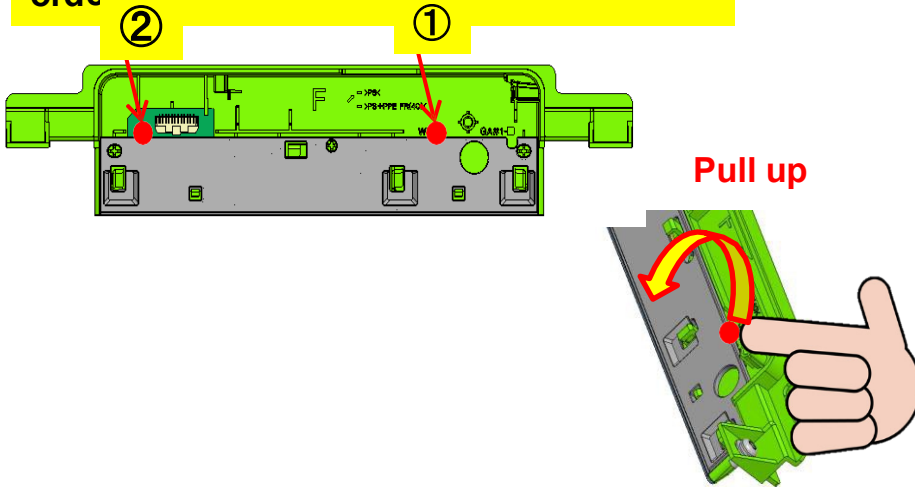

Disassemble Panel Ornament

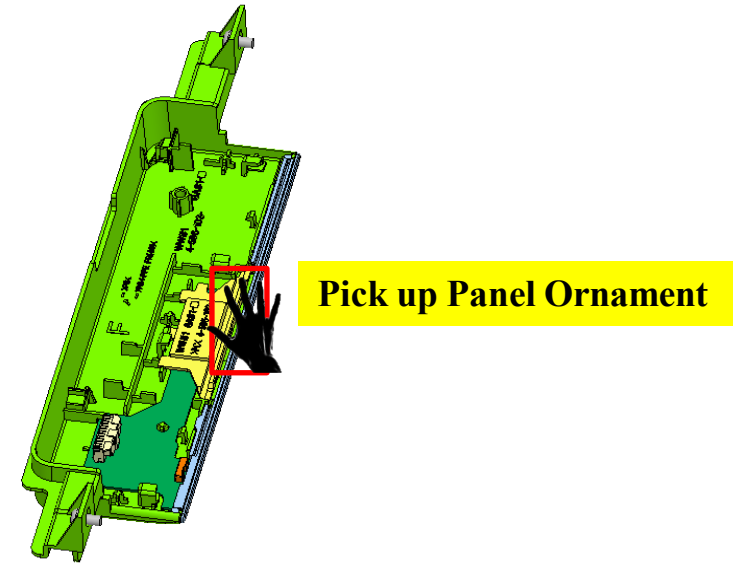

Disassemble Guide Light

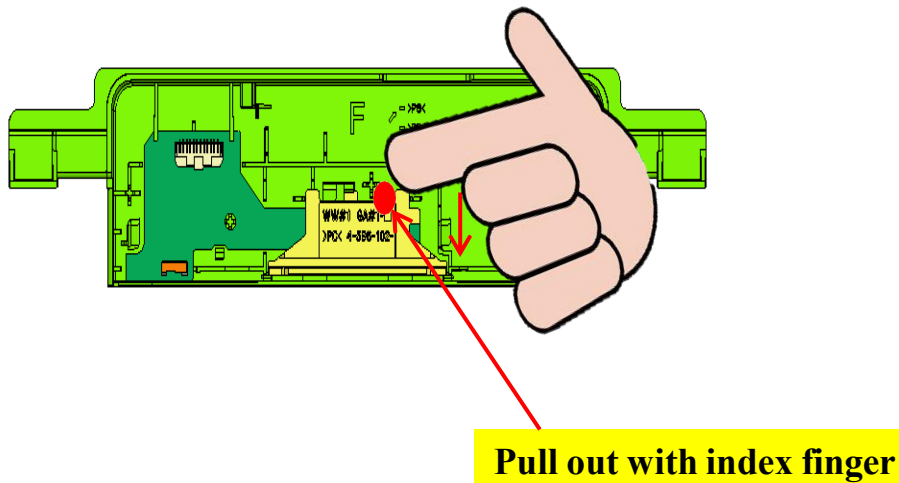

Disassemble H board

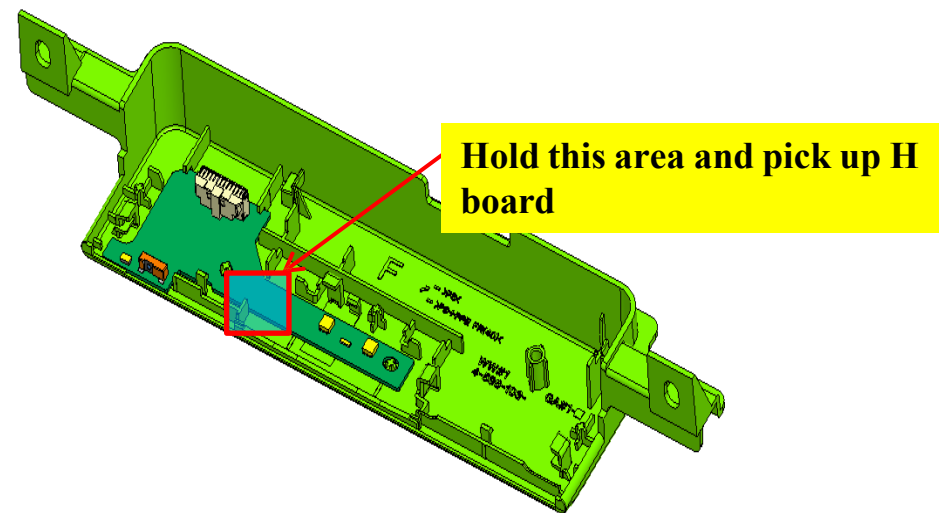

SECTION 2 DIAGRAMS

2.1 Circuit Board Location

2-1-1. 43”

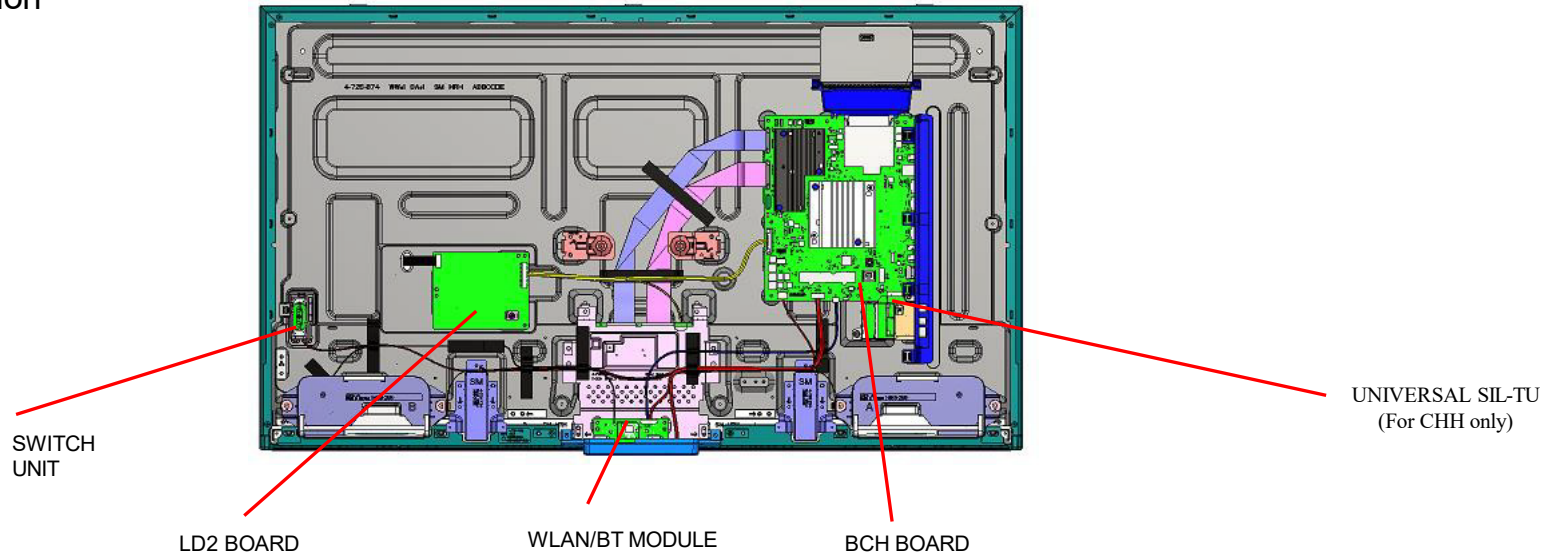

2-1-2. 49”

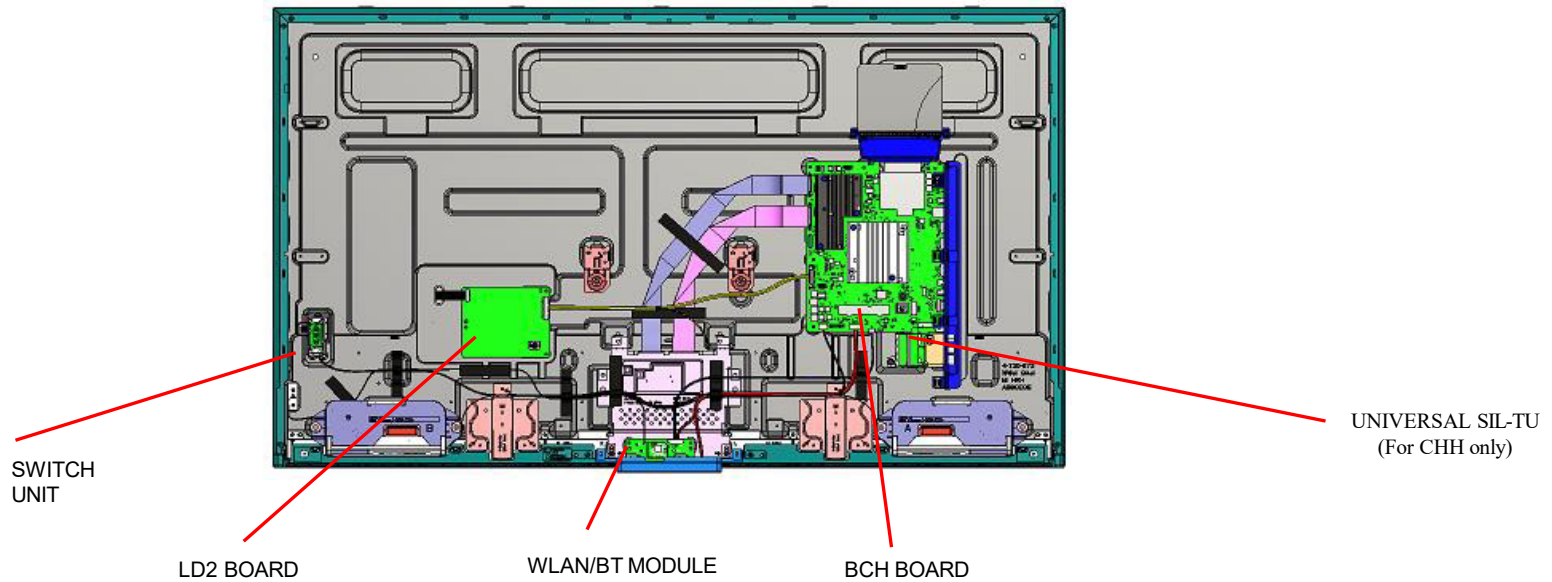

2-1-7. Smart Core

HCA_M2_PONR MOUNT

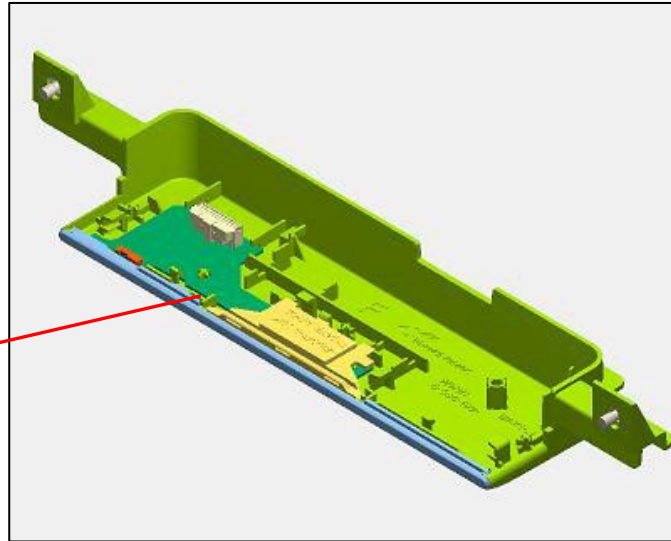

2.2 Wire Dressing : 43”

CONNECT

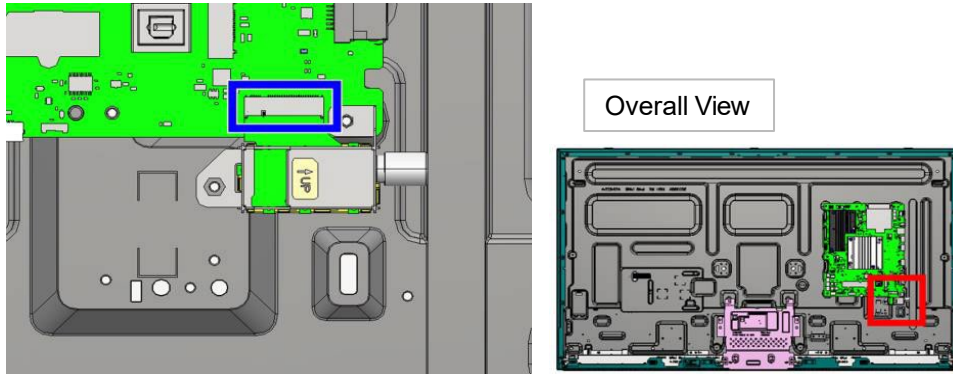

INFORMATION

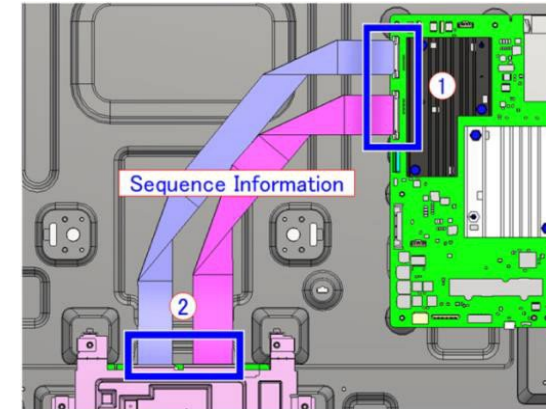

CONNECT 41P

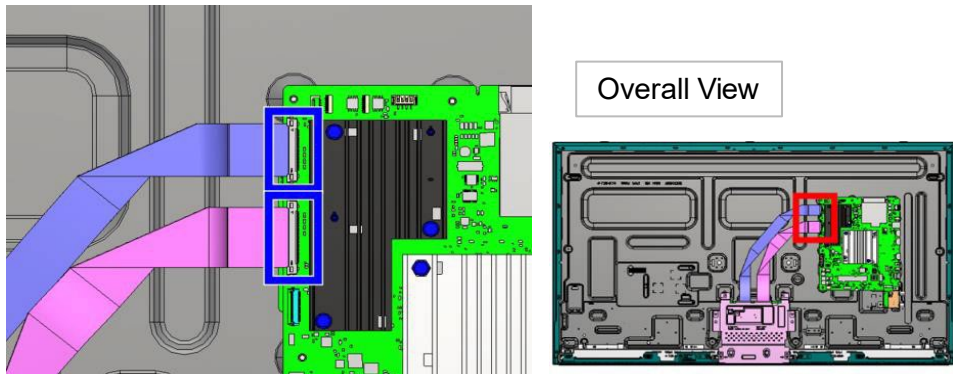

INFORMATION 1

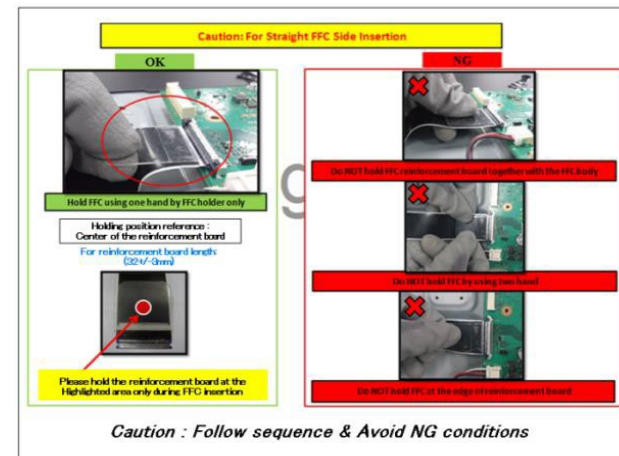

2.2 Wire Dressing : 43”

INFORMATION 2

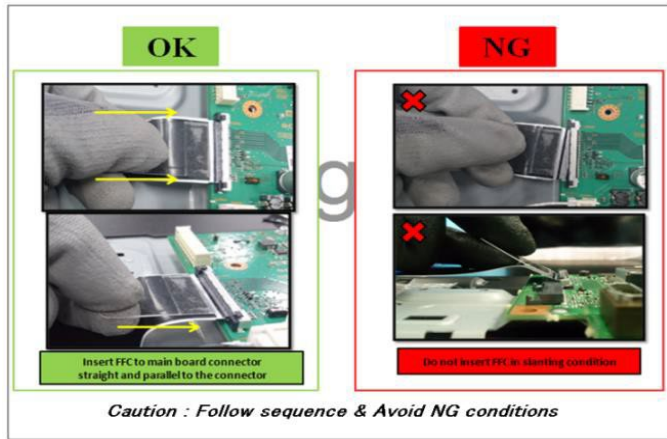

INFORMATION 3

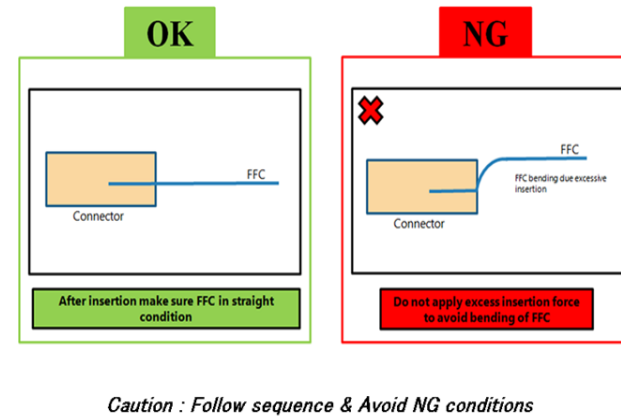

CONNECT 51P

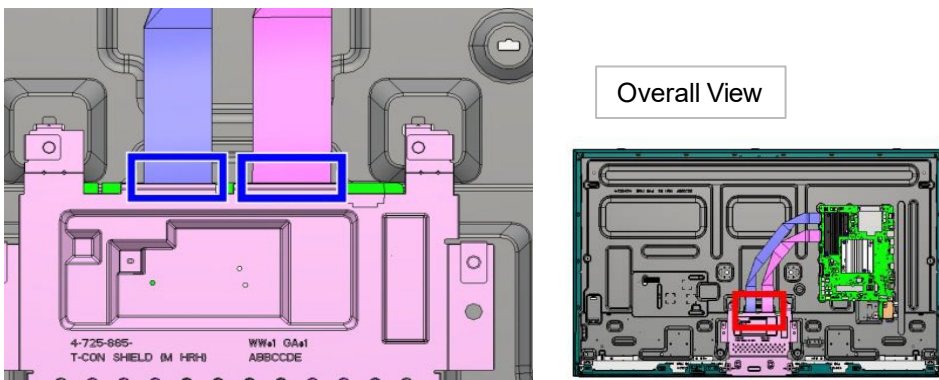

INFORMATION

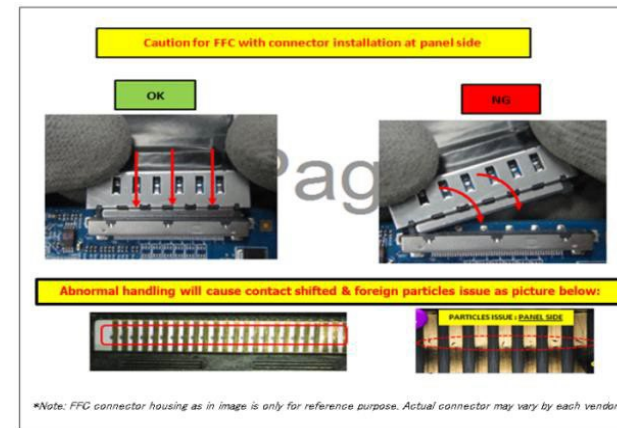

2.2 Wire Dressing : 43”

TAPE

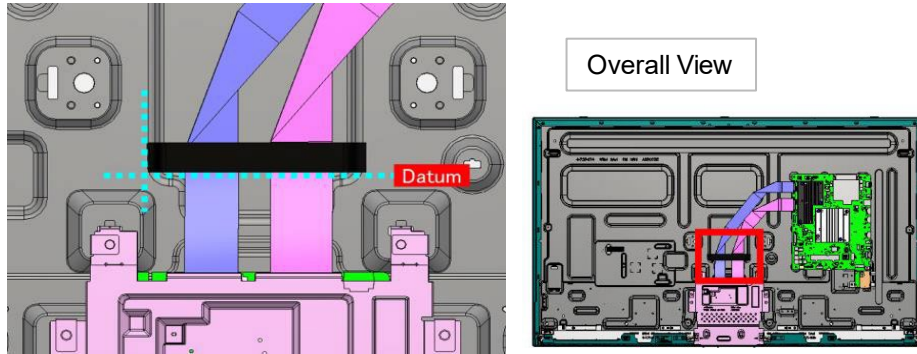

TAPE

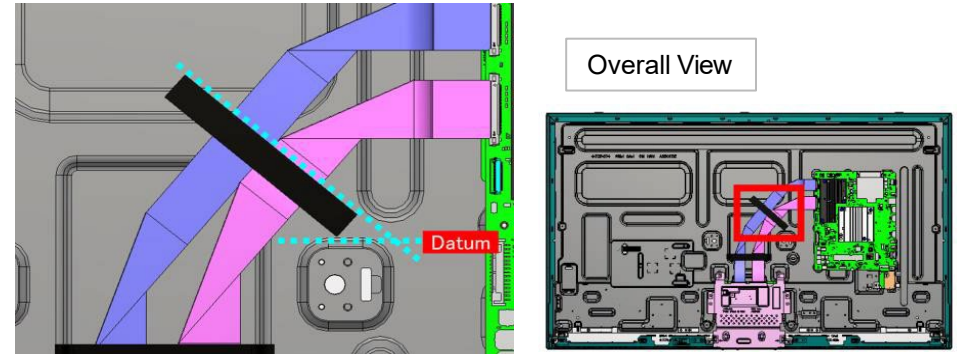

INFORMATION

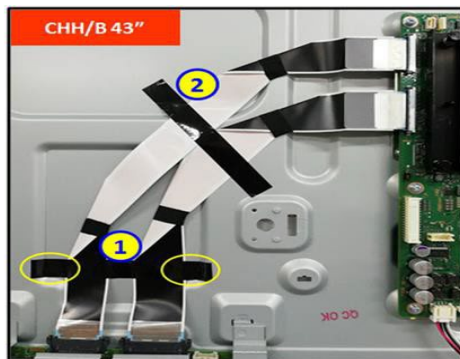

- CAUTION:**
1. Apply rubbing on VA tapes after apply VA tapes on FFC 51P & 41P.
 2. Ensure VA tape (T-CON side) is dressed with equal adhesive area at both ends.

INFORMATION

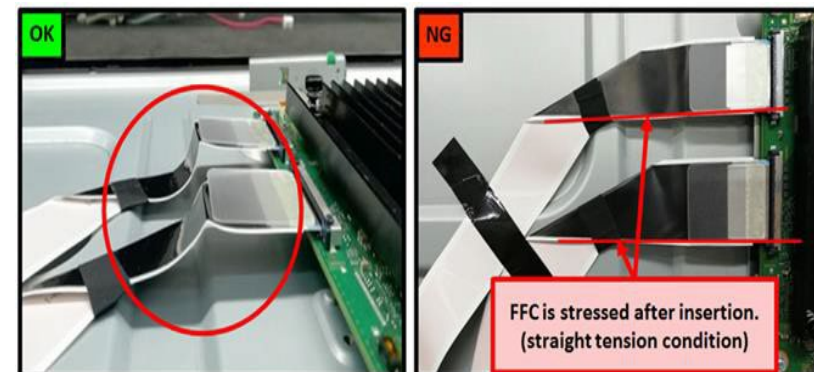

2.2 Wire Dressing : 43"

CONNECT 30P

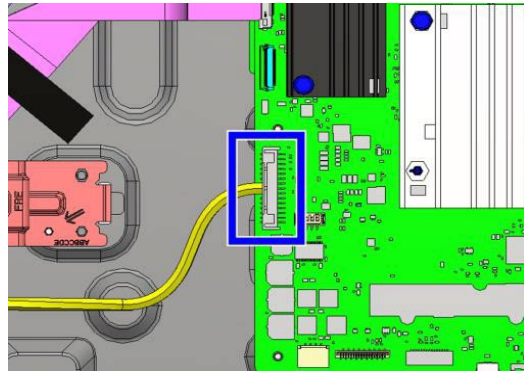

Overall View

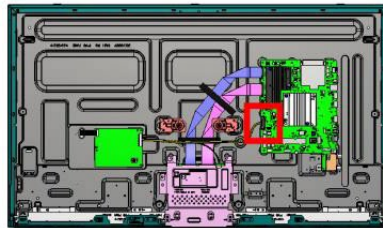

CONNECT

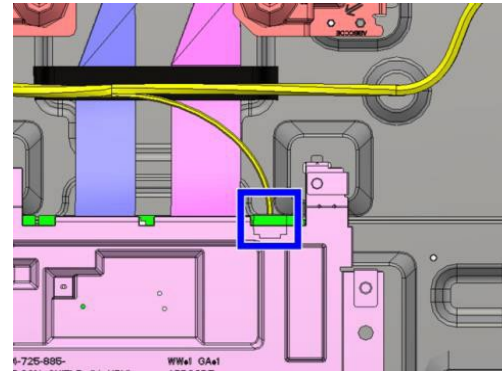

Overall View

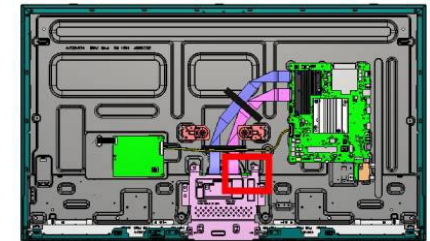

WIRE DRESSING

1

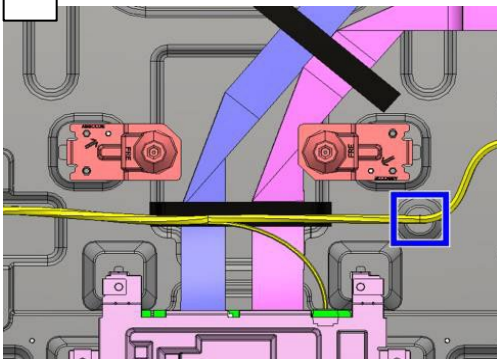

2

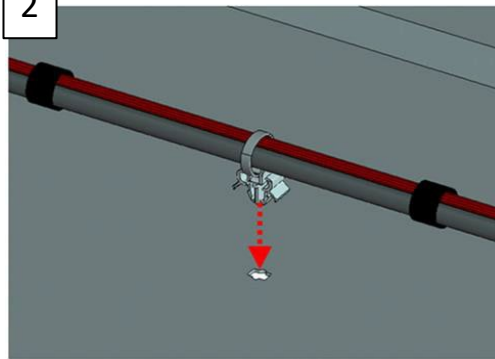

3

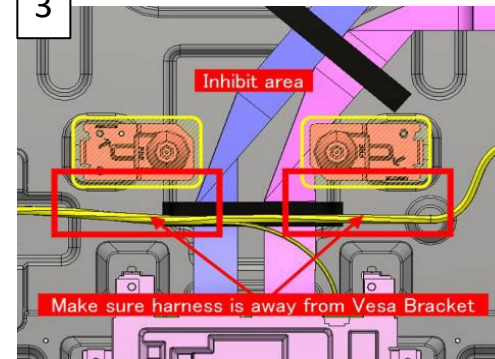

Overall View

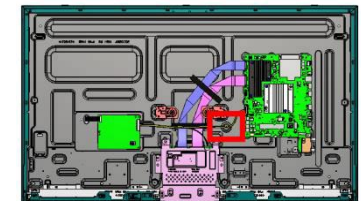

2.2 Wire Dressing : 43”

CONNECT

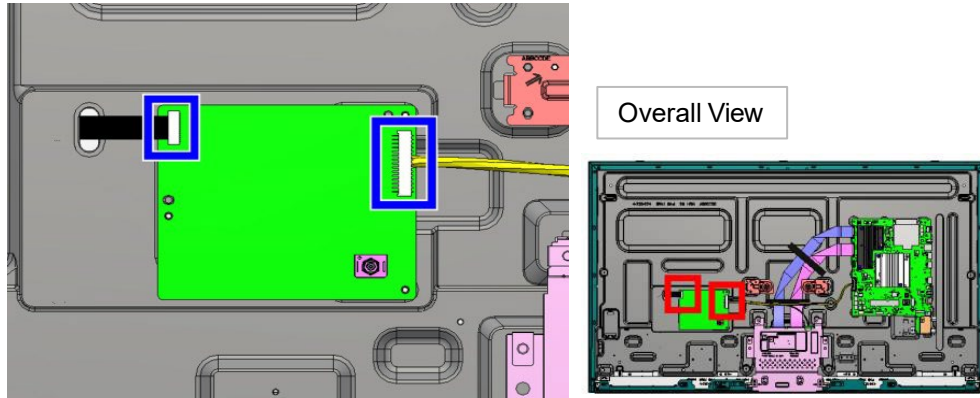

INFORMATION 1

[CHH/B 43"]: SPECIAL HANDLING TO CONTROL CONN ASSY 30P (1/4)

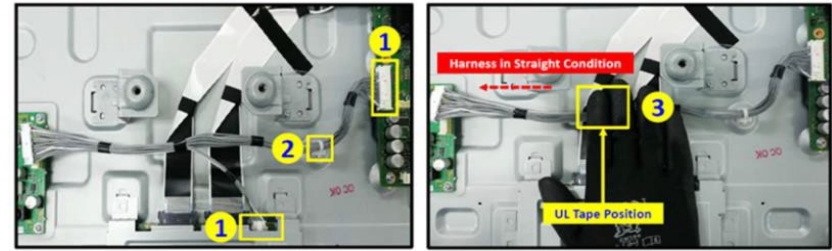

Please follow sequence to connect connectors and cable tie as mentioned below:
 (1) Connect harness connector to Main Board Side & T-Con side.
 (2) Insert cable tie to the hole.

(3) Place your hand on UL Tape position (2nd UL Tape from Power Board).
Caution:
 Before placing harness, ensure wire arrangement is in straight condition and connectors are facing up.

INFORMATION 2

[CHH/B 43"]: SPECIAL HANDLING TO CONTROL CONN ASSY 30P (2/4)

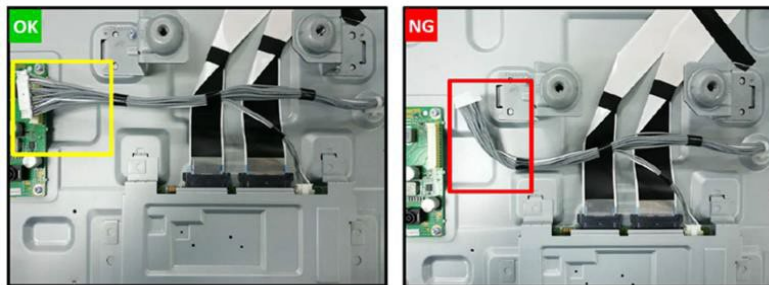

OK Condition:
 Harness is in straight condition and connector is facing up.

NG Condition:
 Harness is not in straight condition and connector is facing down.

INFORMATION 3

[CHH/B 43"]: SPECIAL HANDLING TO CONTROL CONN ASSY 30P (3/4)

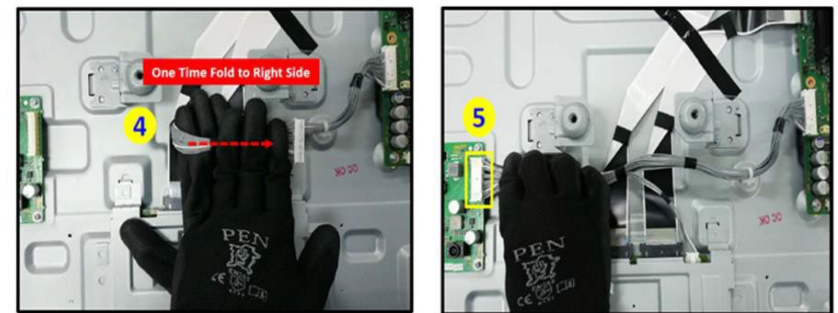

(4) Fold the harness towards right side at one time.

(5) Connect the harness connector to Power Board side.

2.2 Wire Dressing : 43"

INFORMATION 4

[CHH/B 43"] : SPECIAL HANDLING TO CONTROL CONN ASSY 30P (4/4)

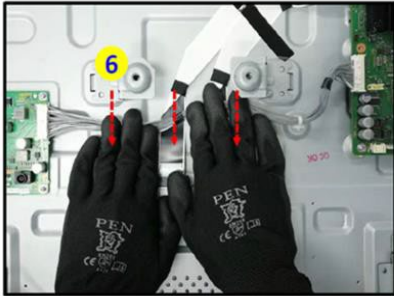

(6) Press harness downwards to back chassis.



Harness will be away from Rear Cover.

CONNECT

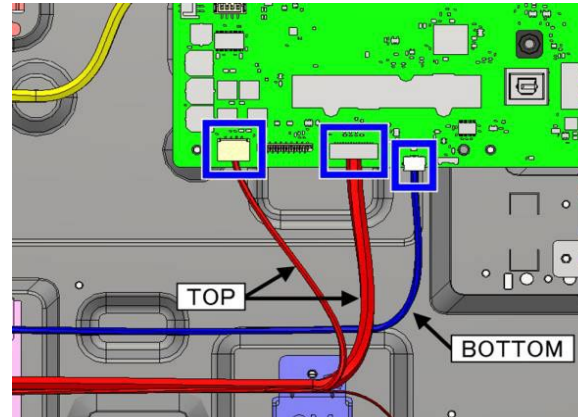

Overall View

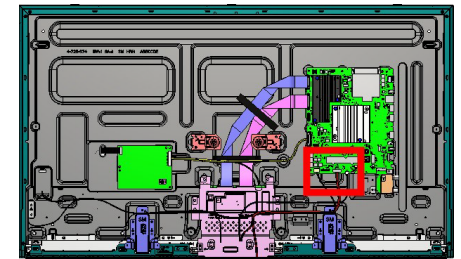

WIRE DRESSING

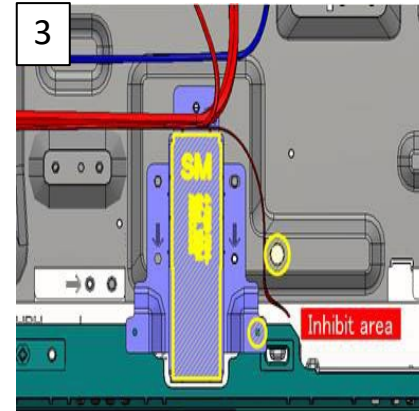
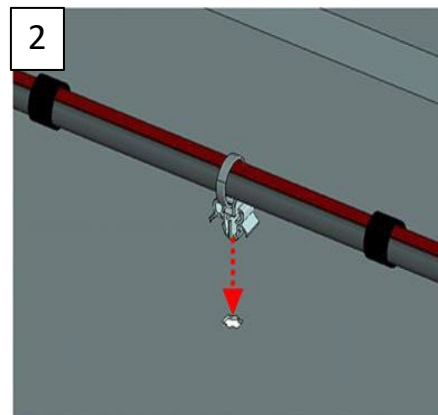
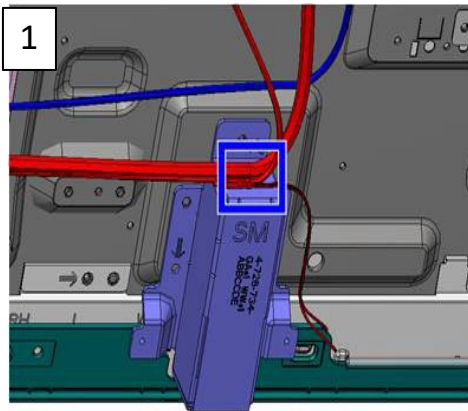

Overall View

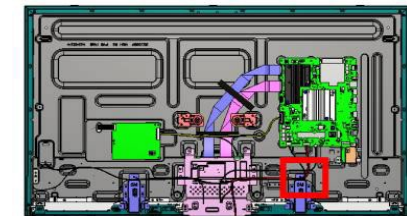

2.2 Wire Dressing : 43”

WIRE DRESSING

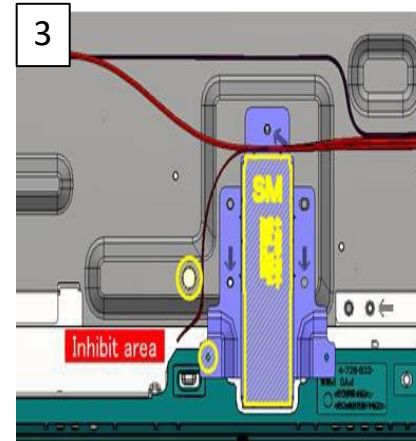
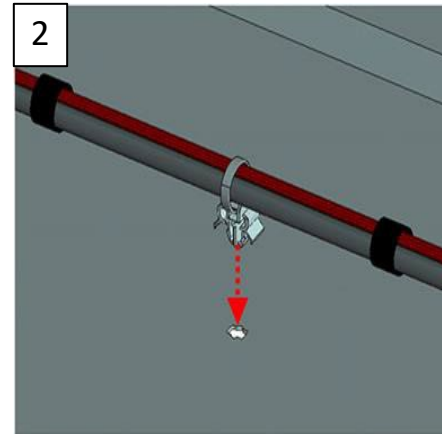
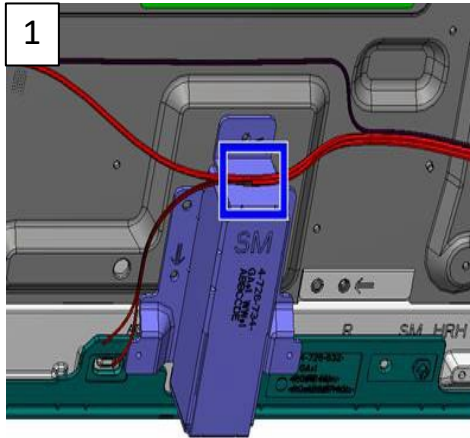

Overall View

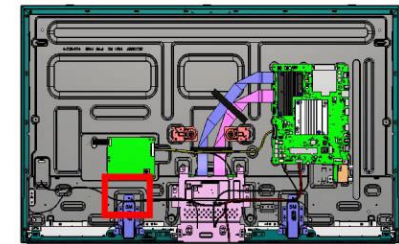

CONNECT

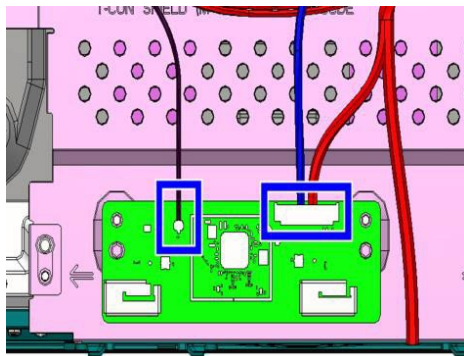

Overall View

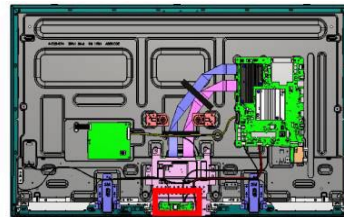

CONNECT

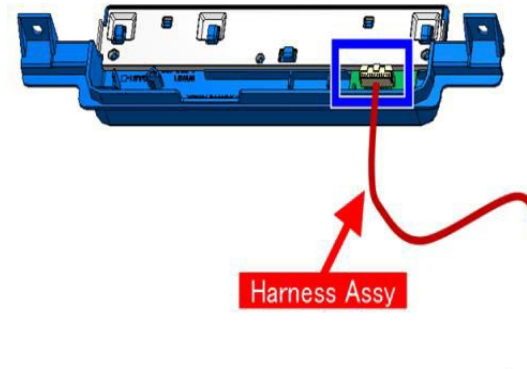

Overall View

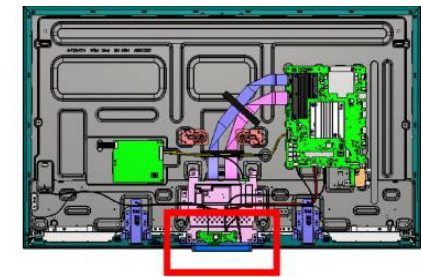

2.2 Wire Dressing : 43”

CONNECT

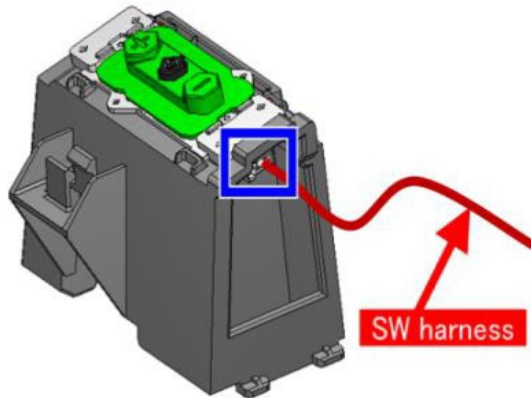

Overall View

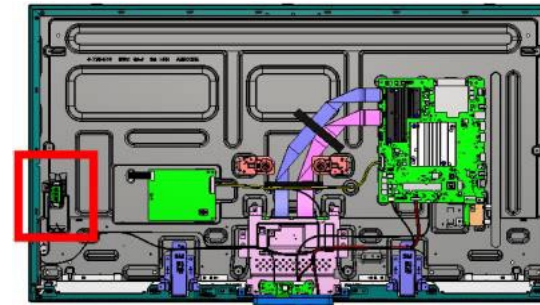

TAPE

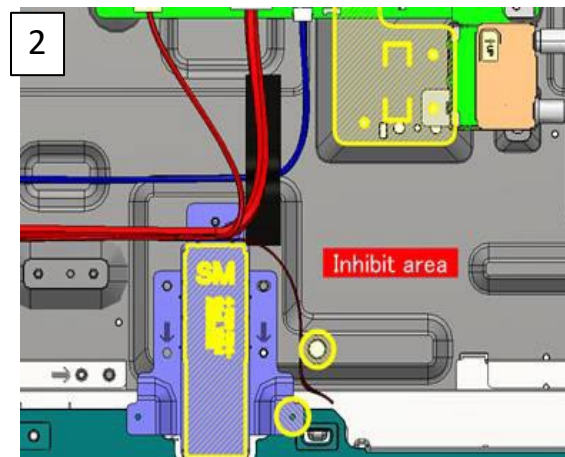
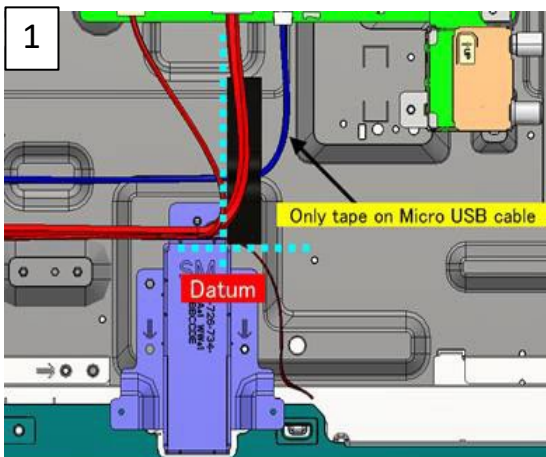

Overall View

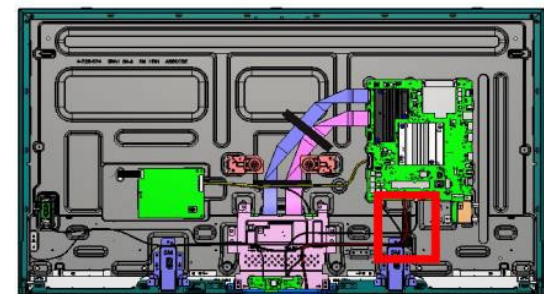

2.2 Wire Dressing : 43”

TAPE

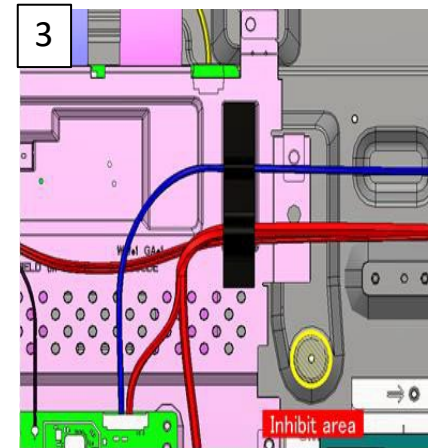
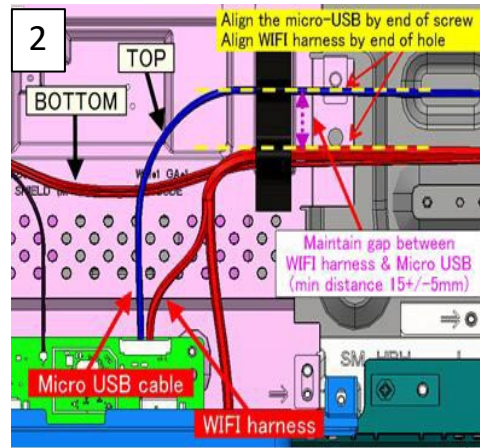
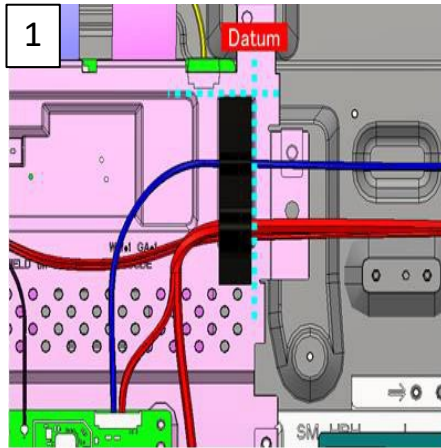

Overall View

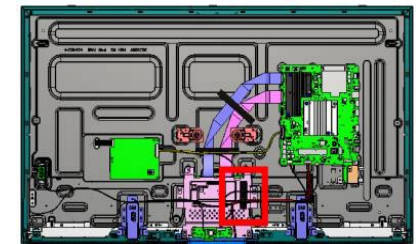

TAPE

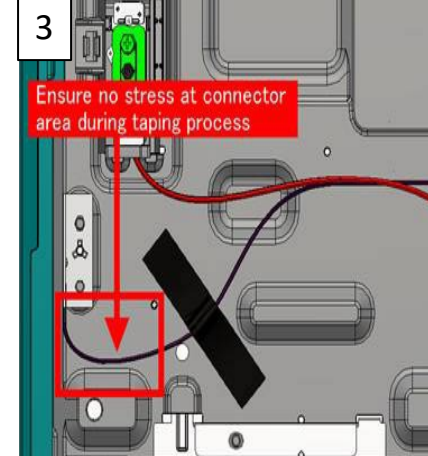
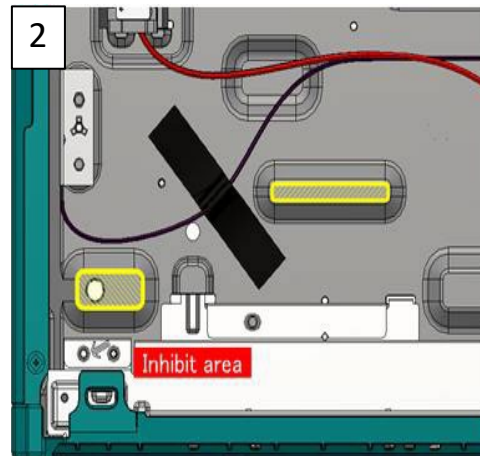
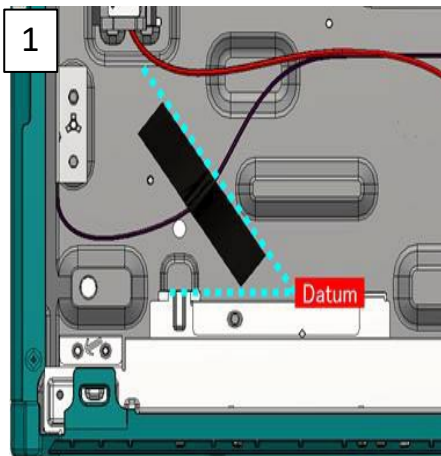

Overall View

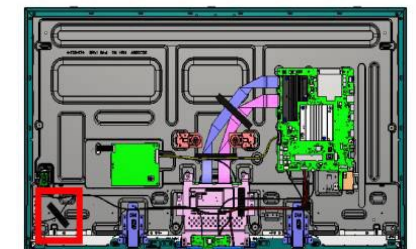

2.2 Wire Dressing : 43”

TAPE

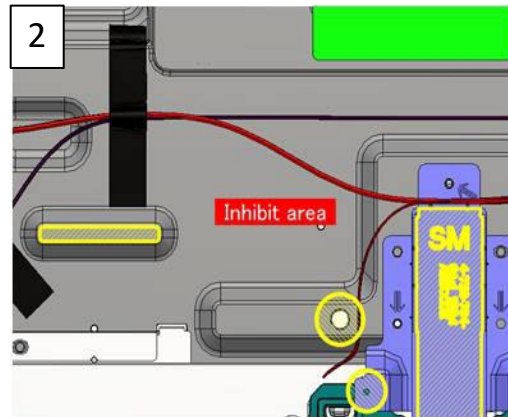
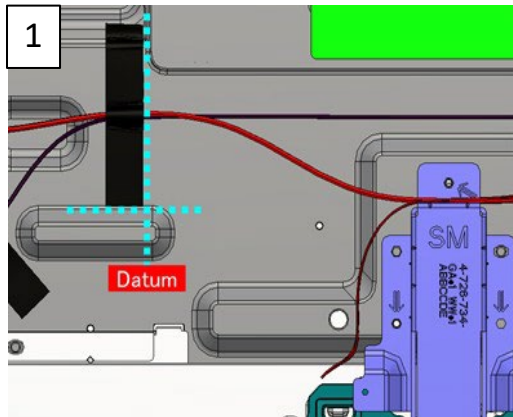

Overall View

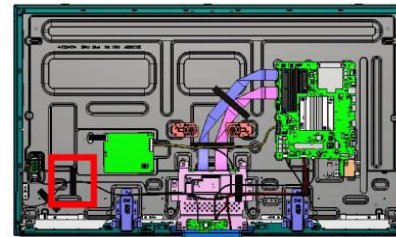

TAPE

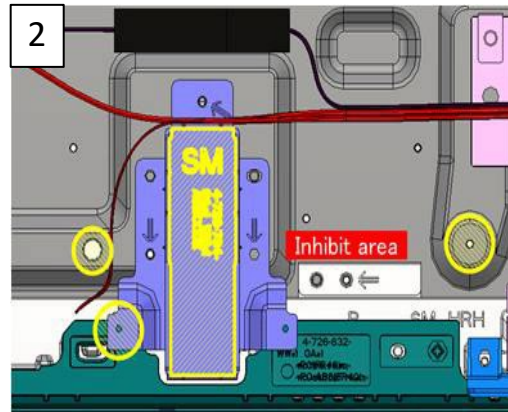
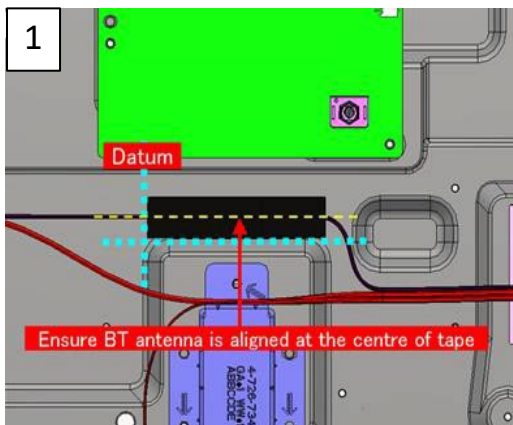

Overall View

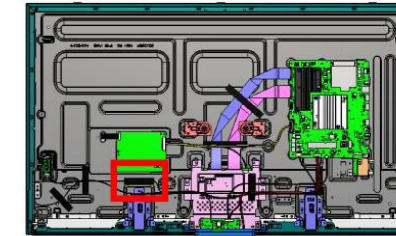

2.2 Wire Dressing : 43"

TAPE

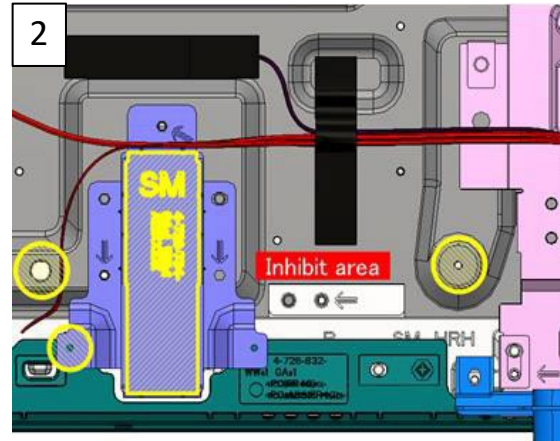
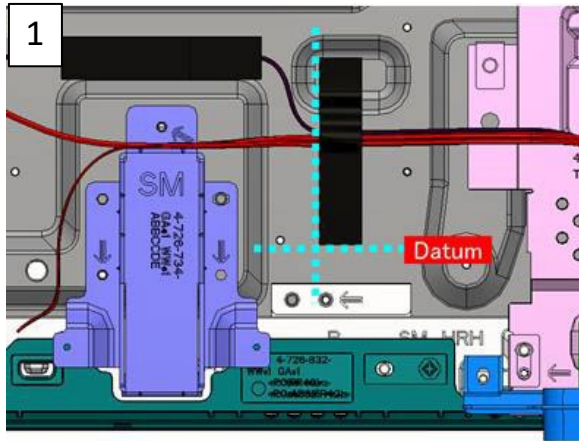

Overall View

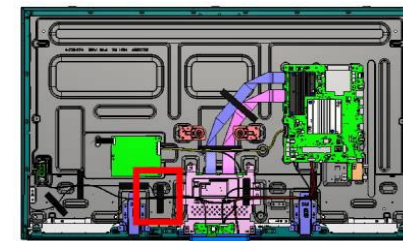

TAPE

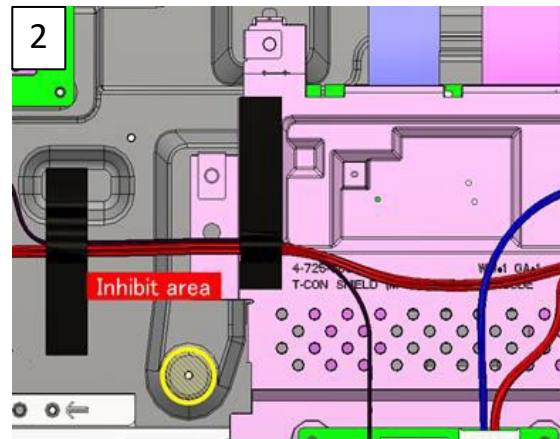
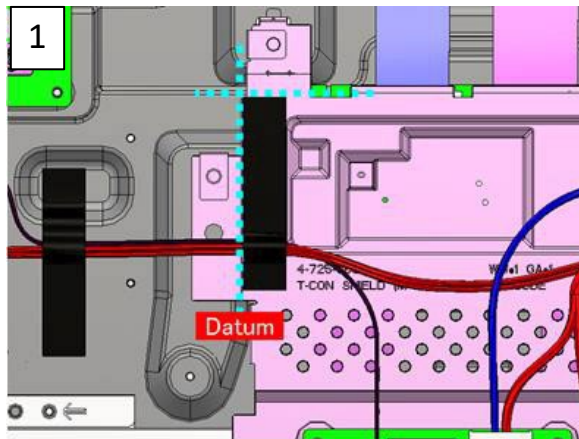

Overall View

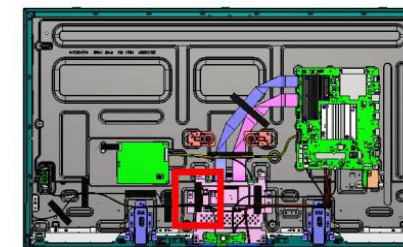

2.2 Wire Dressing : 43”

INFORMATION

Harness Dressing at T-Con Area

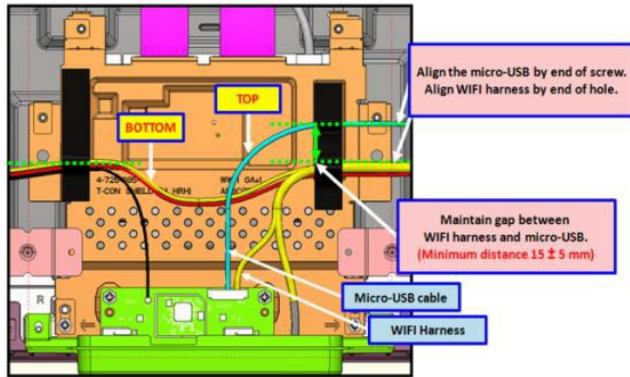

INFORMATION

- CAUTION:**
1. Ensure micro-USB and WIFI harness is not in twisted condition.
 2. Ensure the dressing of micro-USB on top of Speaker (R) harness with correct datum.

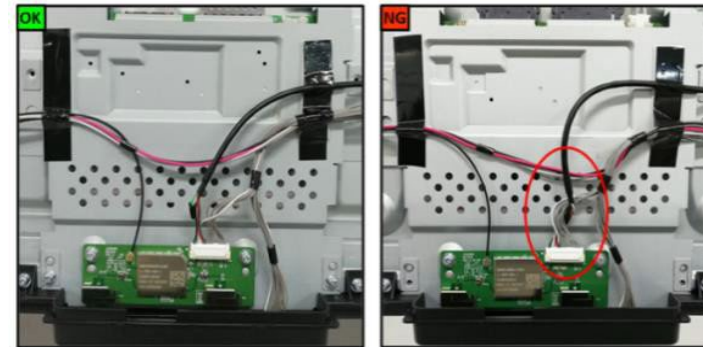

CONNECT

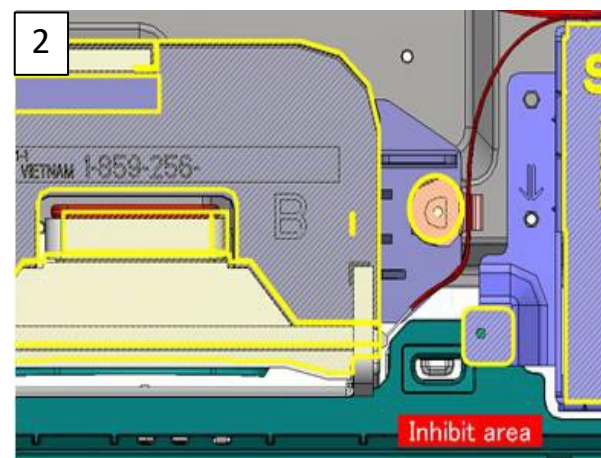
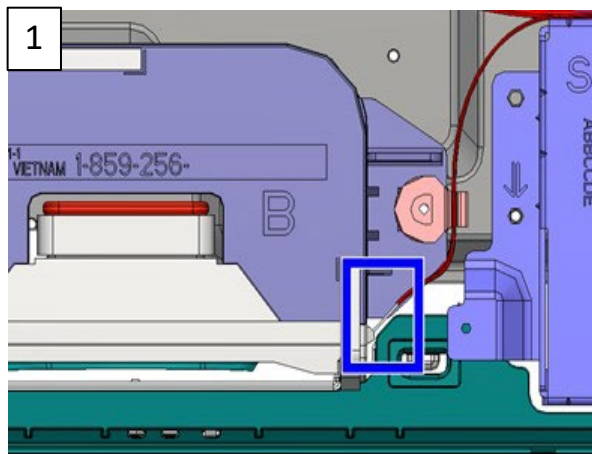

Overall View

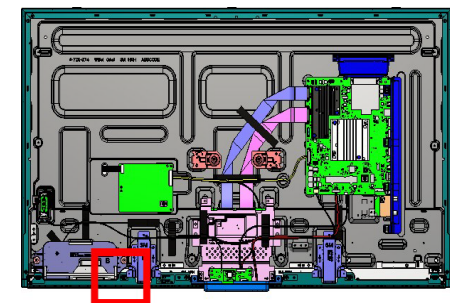

2.2 Wire Dressing : 43”

WIRE DRESSING

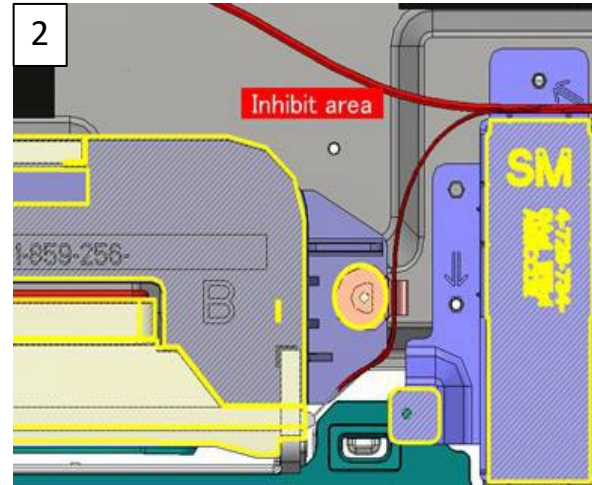
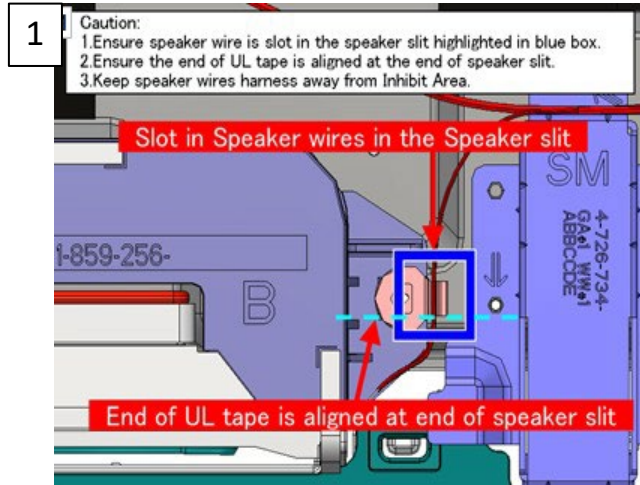

Overall View

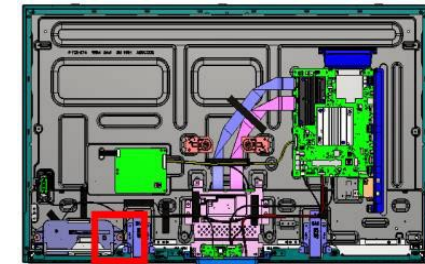

INFORMATION 1

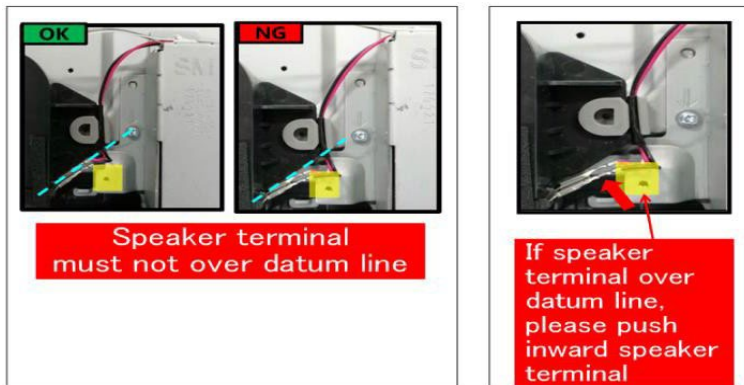

INFORMATION 2

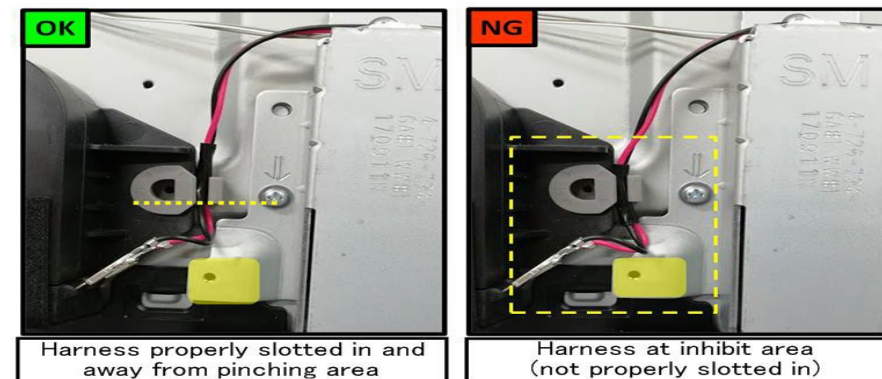

2.2 Wire Dressing : 43”

CONNECT

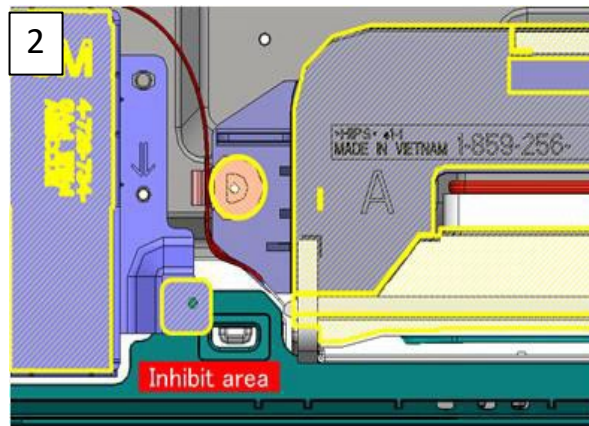
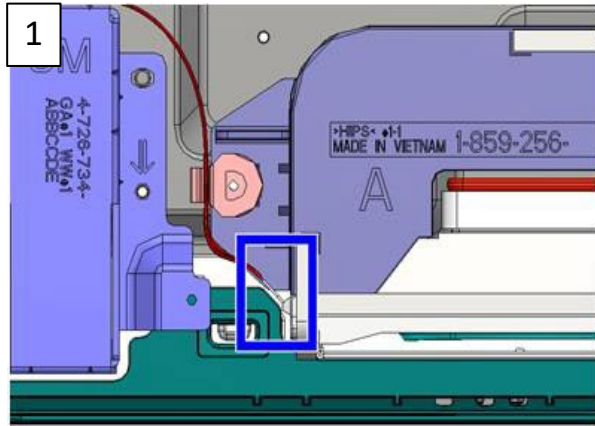

Overall View

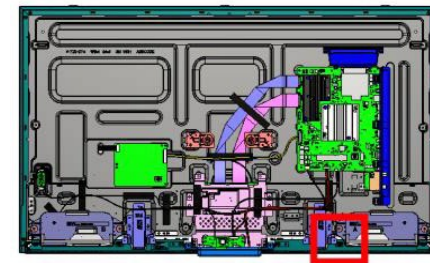

WIRE DRESSING

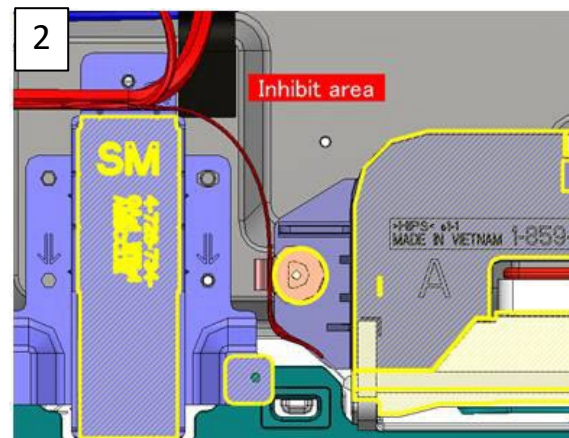
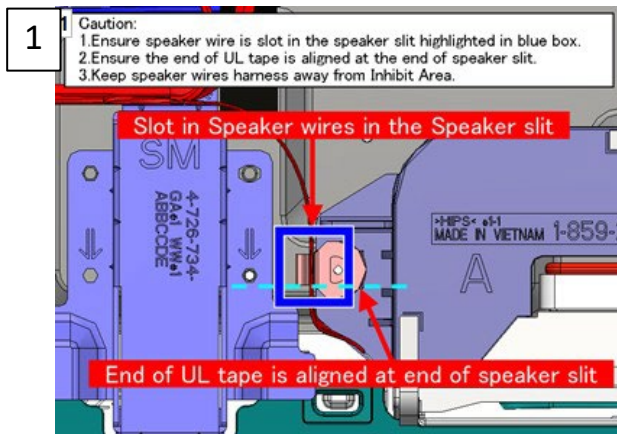

Overall View

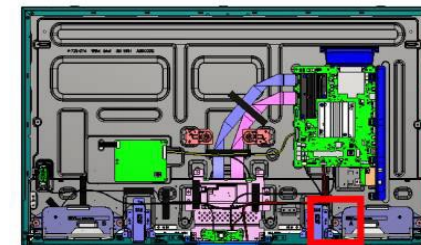

2.2 Wire Dressing : 43”

INFORMATION 1

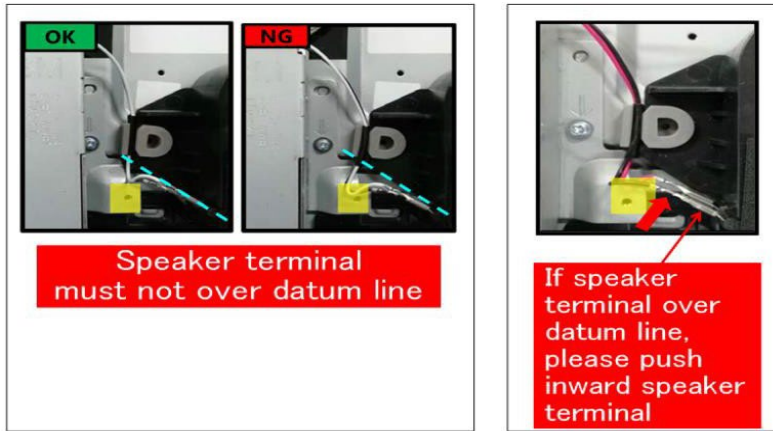

INFORMATION 2

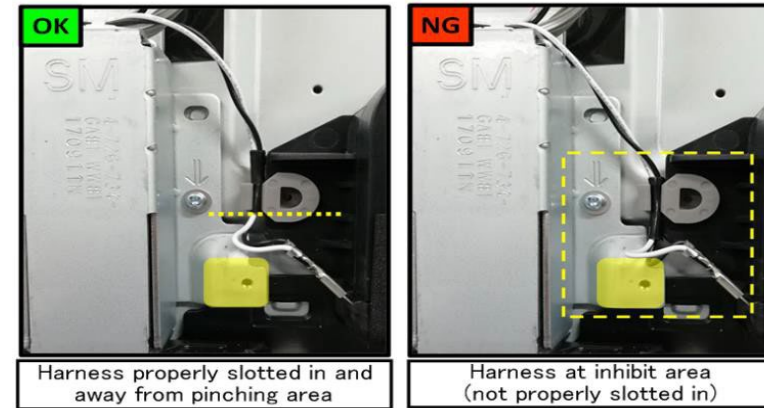

INFORMATION

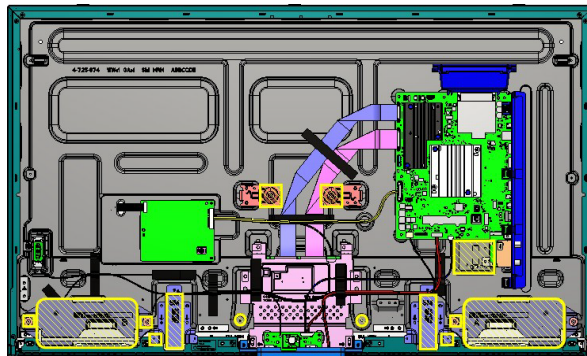

Caution : Keep wire harness away from Inhibit Area

2.2 Wire Dressing : 43”

CONNECT

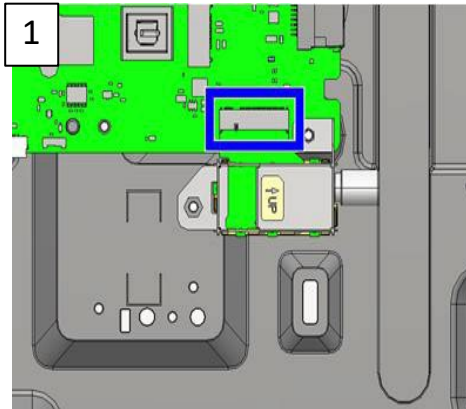

Overall View

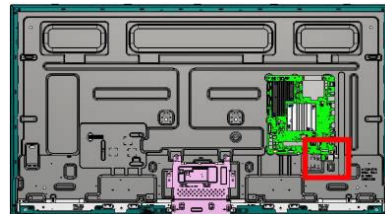

INFORMATION

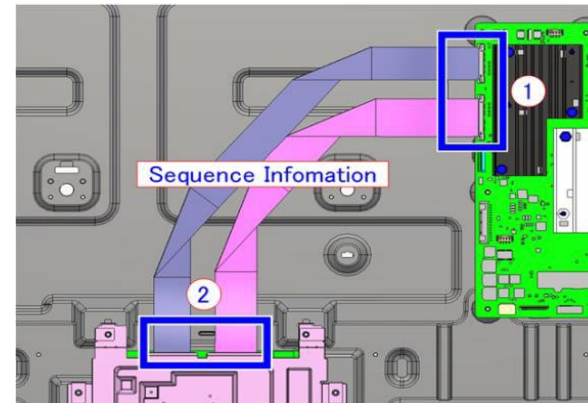

CONNECT 41P

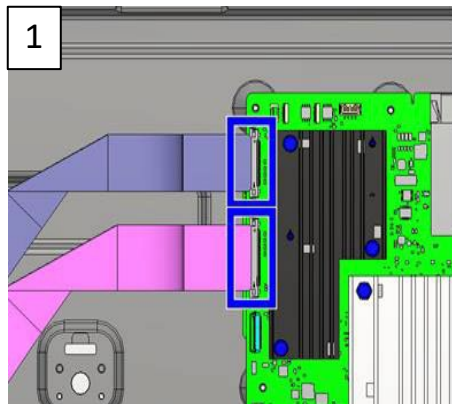

Overall View

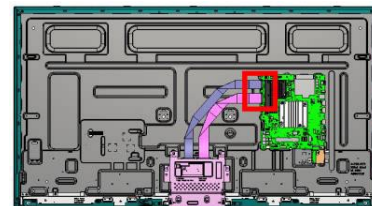

INFORMATION 1

Caution: For Straight FFC Side Insertion

OK	NG
<p>Hold FFC using one hand by FFC holder only</p>	<p>Do NOT hold FFC reinforcement board together with the FFC body</p>
<p>Holding position reference: Center of the reinforcement board For reinforcement board length: (204~31mm)</p>	<p>Do NOT hold FFC by using two hands</p>
<p>Please hold the reinforcement board at the highlighted area only during FFC insertion.</p>	<p>Do NOT hold FFC at the edge of reinforcement board</p>

Caution : Follow sequence & Avoid NG conditions

2.2 Wire Dressing : 49”

INFORMATION 2

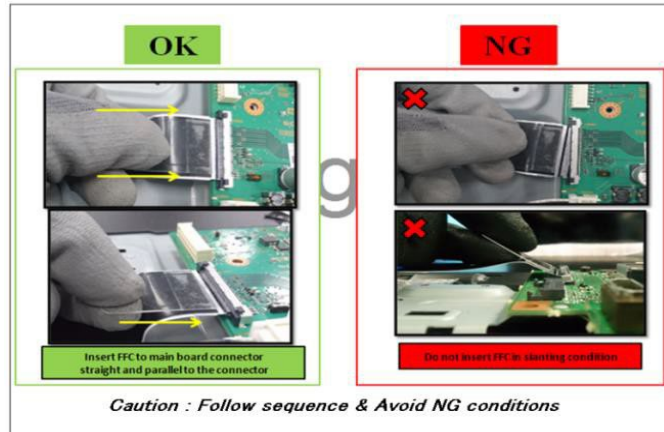

INFORMATION 3

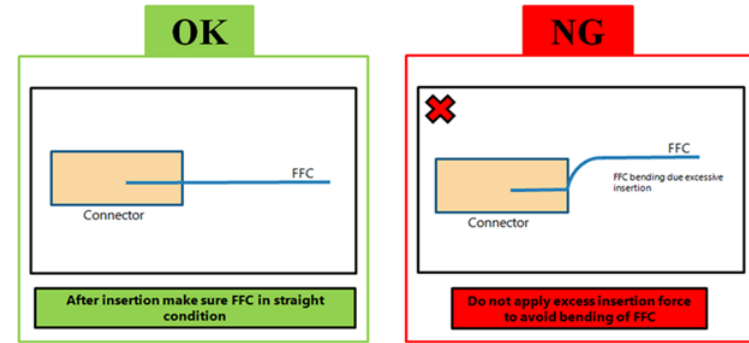

CONNECT 51P

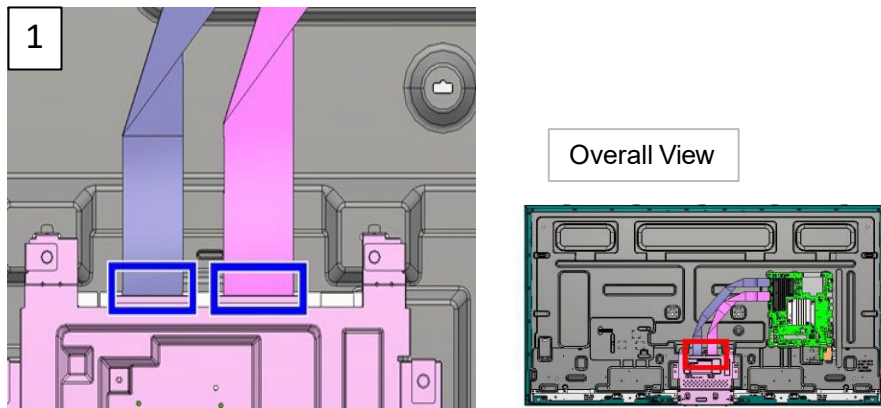

INFORMATION

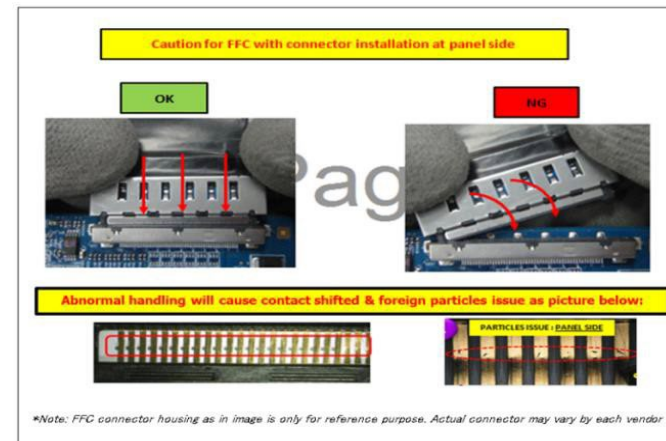

2.2 Wire Dressing : 49”

TAPE

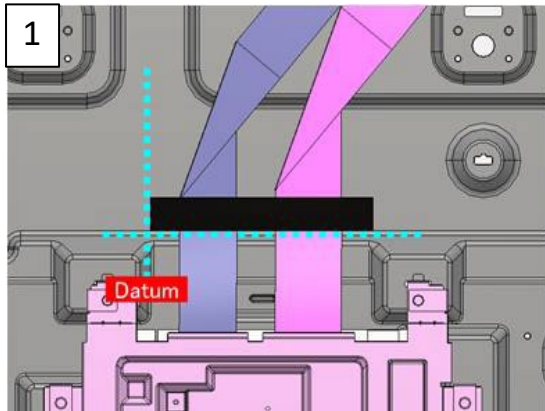

Overall View

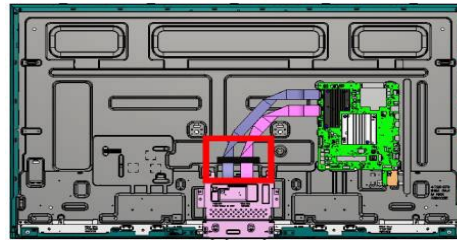

TAPE

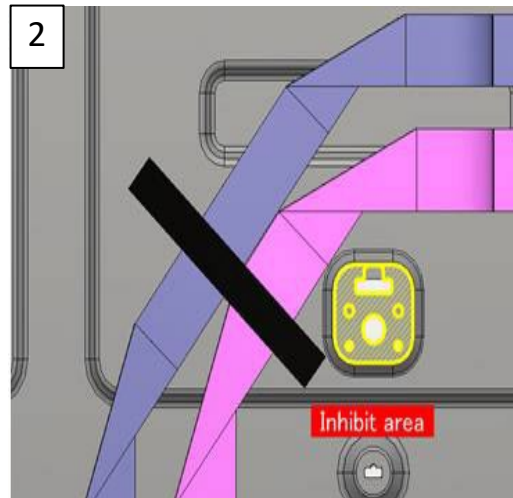
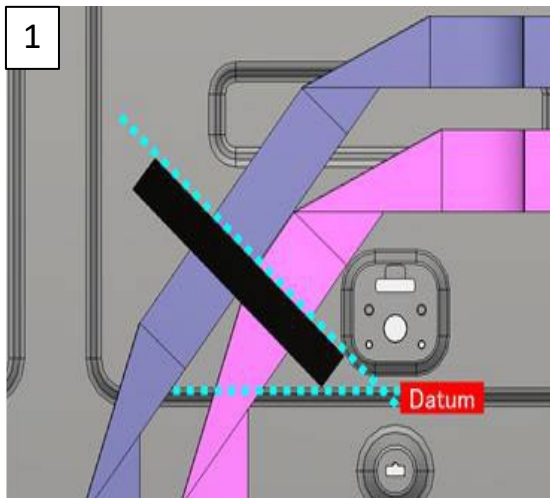

Overall View

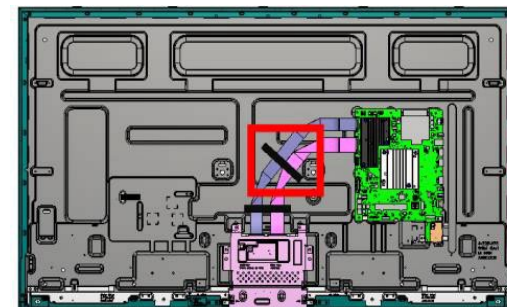

2.2 Wire Dressing : 49"

INFORMATION



CAUTION:
1. Apply rubbing on VA tapes after apply VA tapes on FFC 51P & 41P.
2. Ensure VA tape (T-CON side) is dressed with equal adhesive area at both ends.

INFORMATION

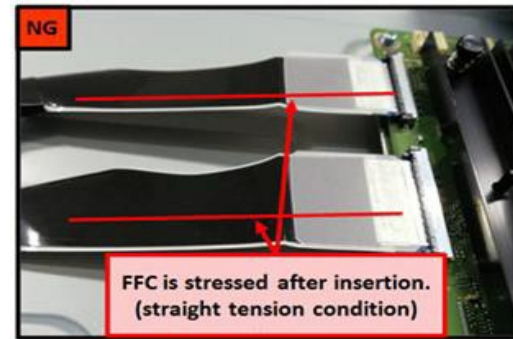
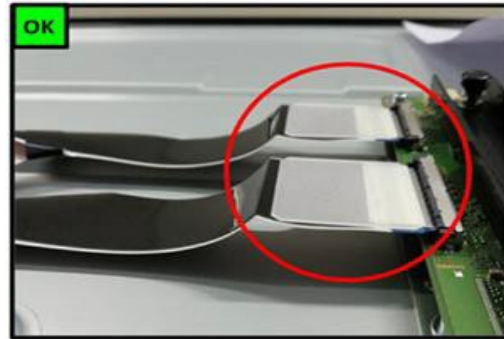

TAPE

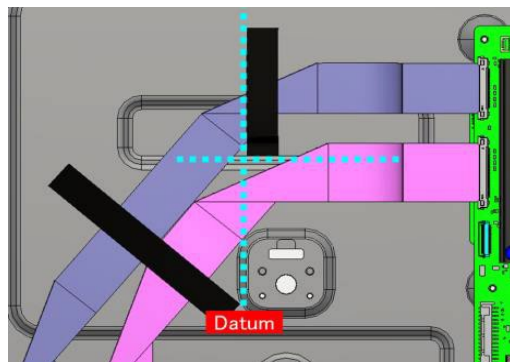

Overall View

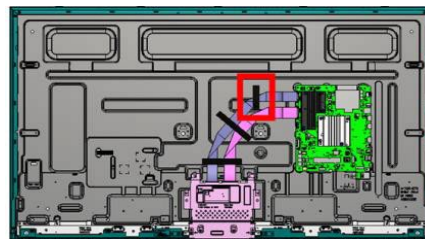

TAPE

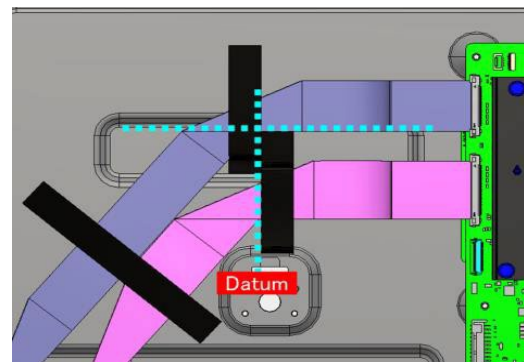

Overall View

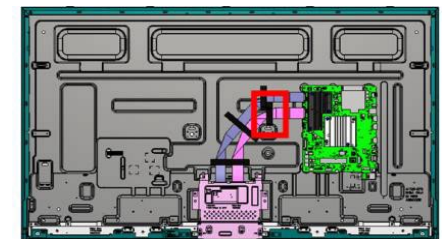

2.2 Wire Dressing : 49"

INFORMATION

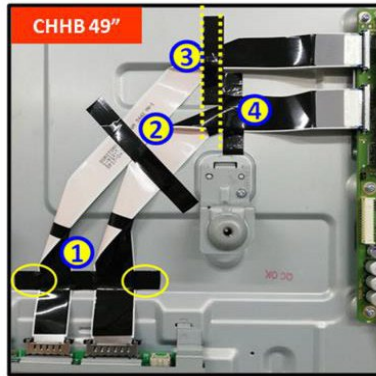

CAUTION:

1. Apply rubbing on VA tapes after apply VA tapes on FFC 51P & 41P.
2. Ensure VA tape (T-CON side) is dressed with equal adhesive area at both ends.

INFORMATION

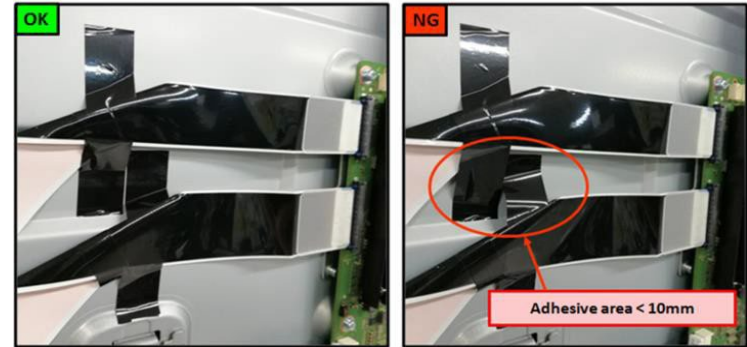

CAUTION:

1. Apply rubbing on VA tapes after applied VA tapes on FFC 51P & 41P.
2. Ensure VA tapes adhesive area of >10mm for both ends.

CONNECT 30P

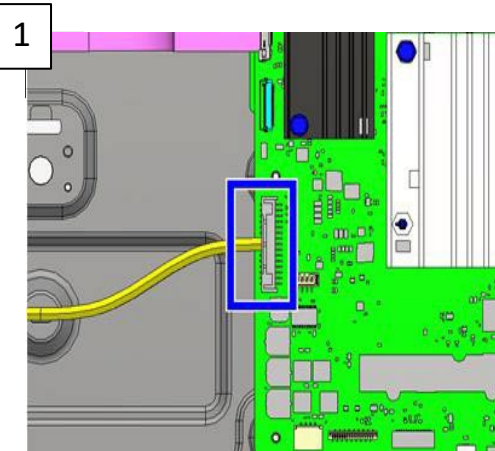

Overall View

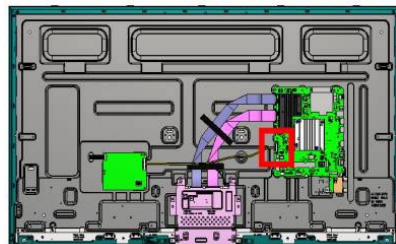

CONNECT

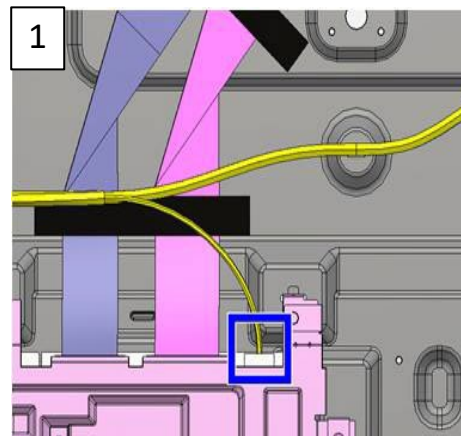

Overall View

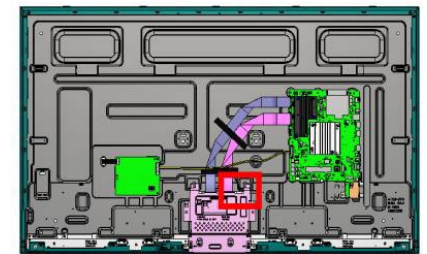

2.2 Wire Dressing : 49"

WIRE DRESSING

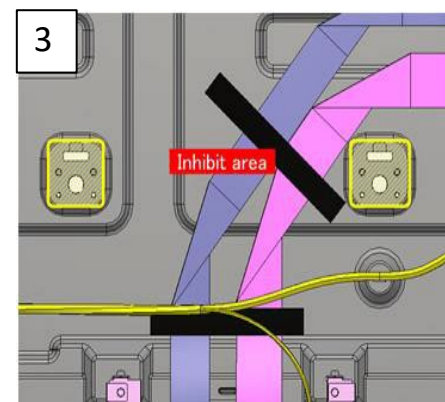
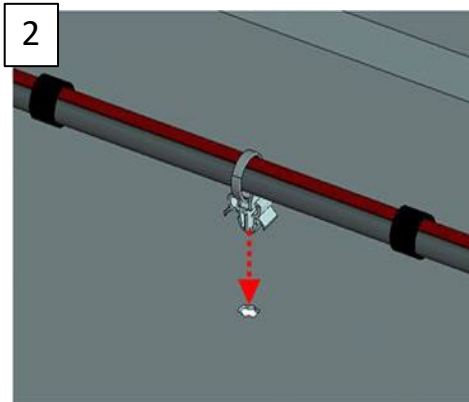
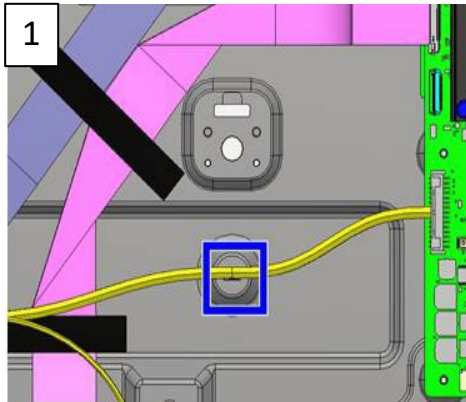

Overall View

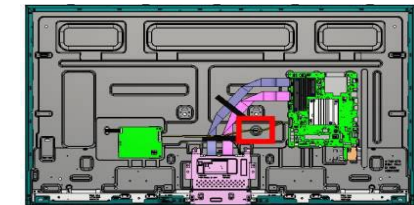

CONNECT

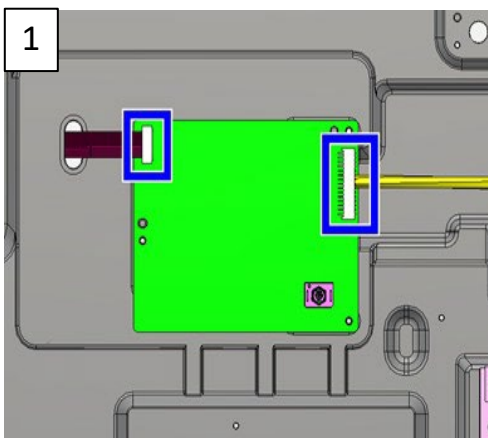

Overall View

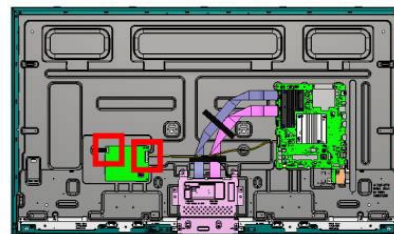

INFORMATION 1

[CHH/B 49"]: SPECIAL HANDLING TO CONTROL CONN ASSY 30P (1/4)

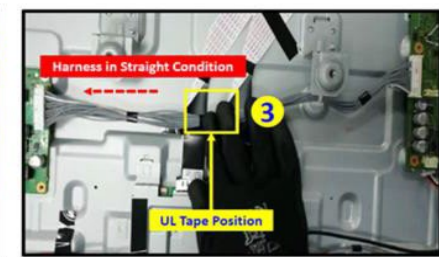
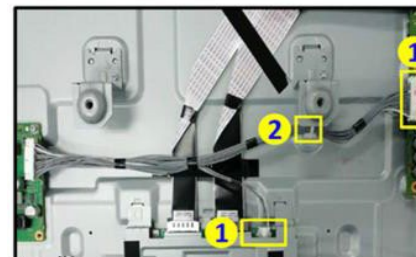

Please follow sequence to connect connectors and cable tie as mentioned below:
 (1) Connect harness connector to Main Board Side & T-Con side.
 (2) Insert cable tie to the hole.

(3) Place your hand on UL Tape position (2nd UL Tape from Power Board).

Caution:
 Before placing harness, ensure wire arrangement is in straight condition and connectors are facing up.

2.2 Wire Dressing : 49”

INFORMATION 2

[CHH/B 49"]: SPECIAL HANDLING TO CONTROL CONN ASSY 30P (2/4)

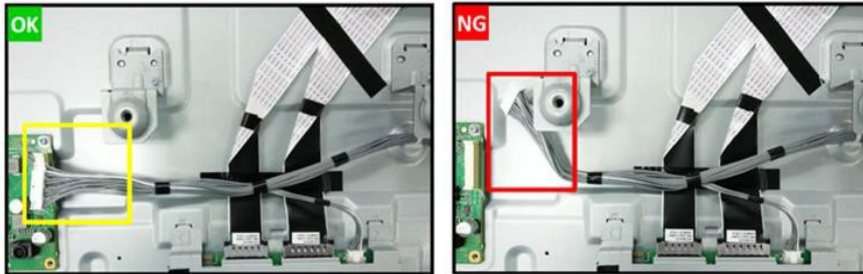

OK Condition:
Harness is in straight condition and connector is facing up.

NG Condition:
Harness is not in straight condition and connector is facing down.

INFORMATION 3

[CHH/B 49"]: SPECIAL HANDLING TO CONTROL CONN ASSY 30P (3/4)

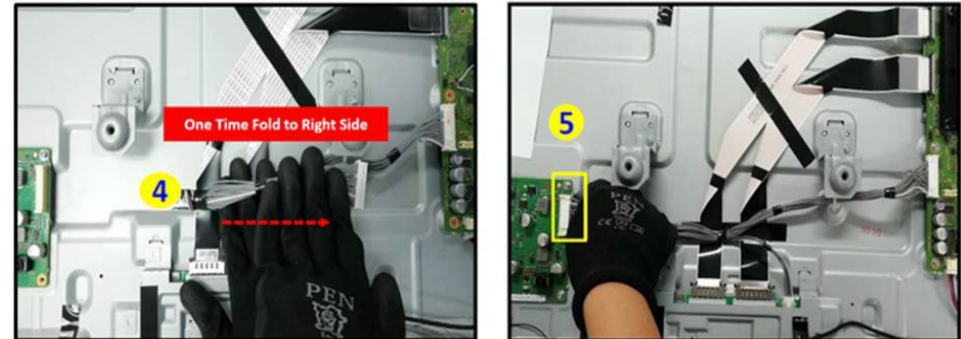

(4) Fold the harness towards right side at one time.

(5) Connect the harness connector to Power Board side.

INFORMATION 4

[CHH/B 49"]: SPECIAL HANDLING TO CONTROL CONN ASSY 30P (4/4)

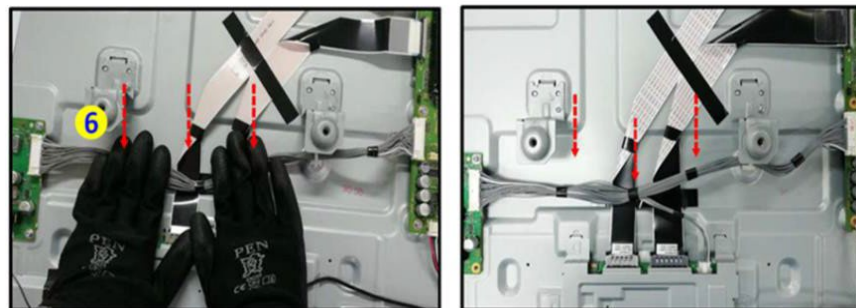

(6) Press harness downwards to back chassis.

Harness will be away from Rear Cover.

CONNECT

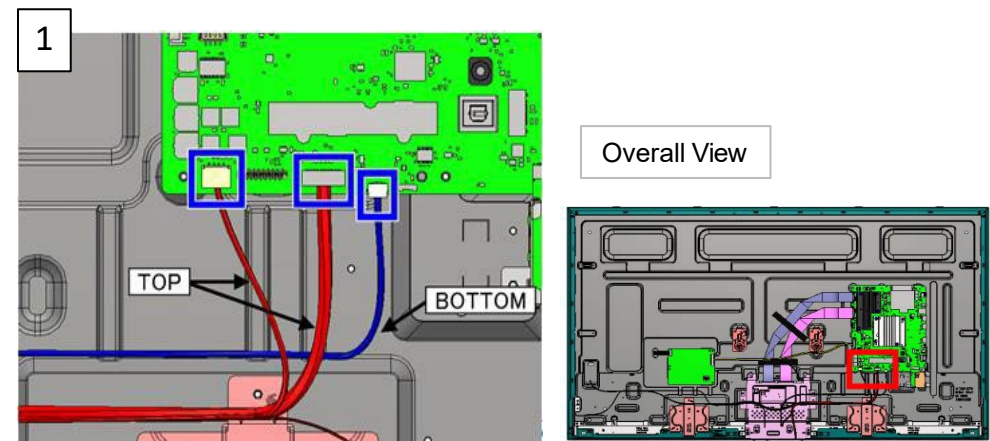

2.2 Wire Dressing : 49”

WIRE DRESSING

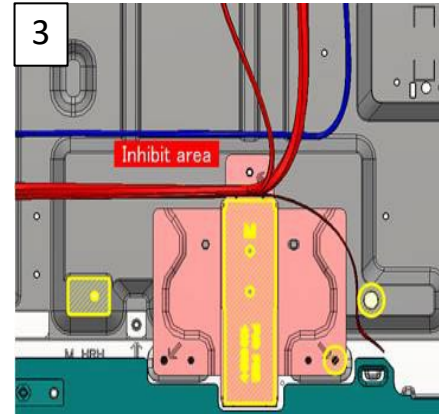
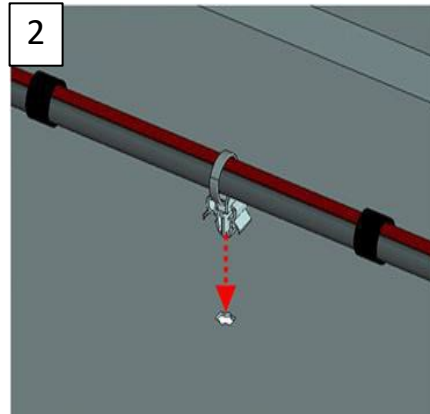
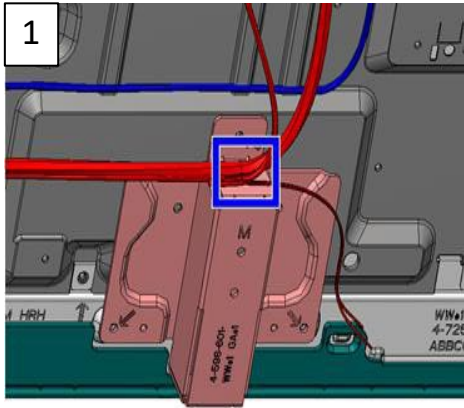

Overall View

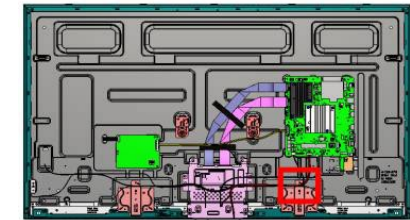

WIRE DRESSING

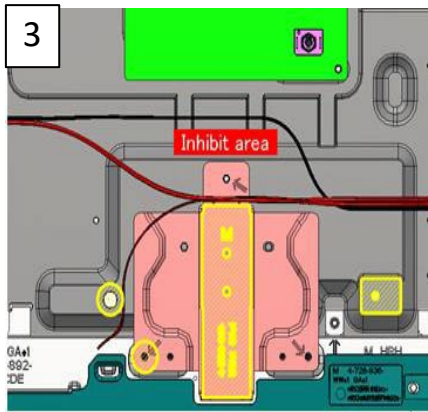
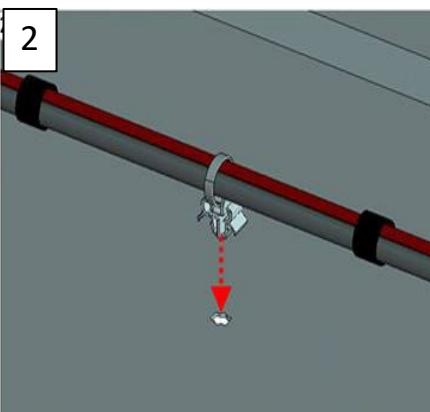
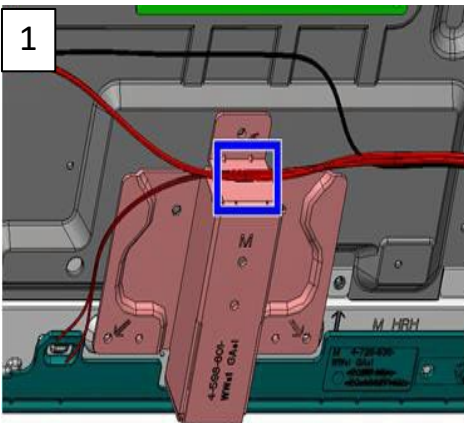

Overall View

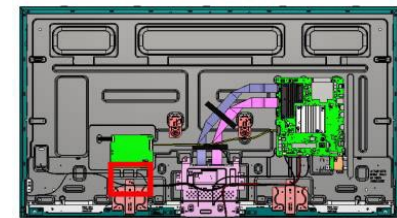

2.2 Wire Dressing : 49”

CONNECT

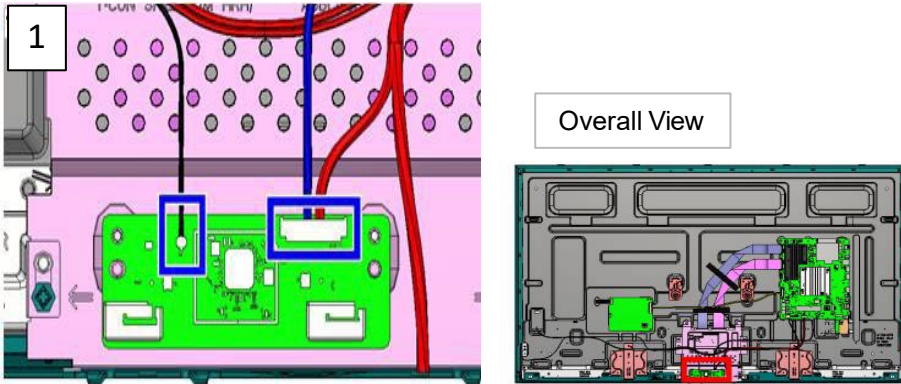

CONNECT

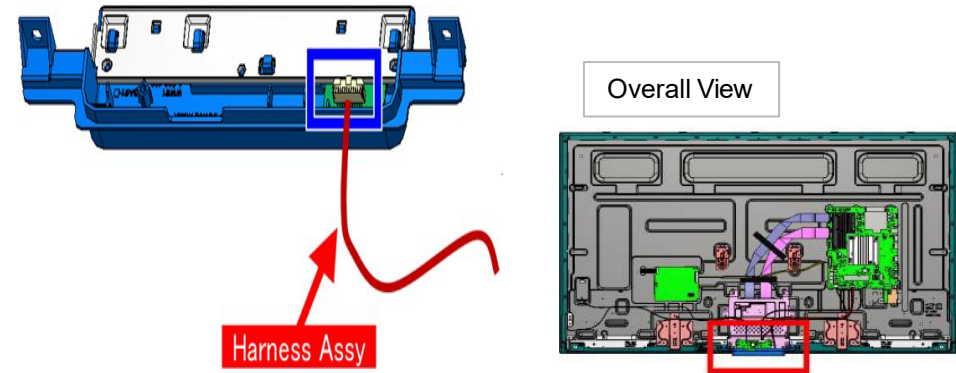

CONNECT

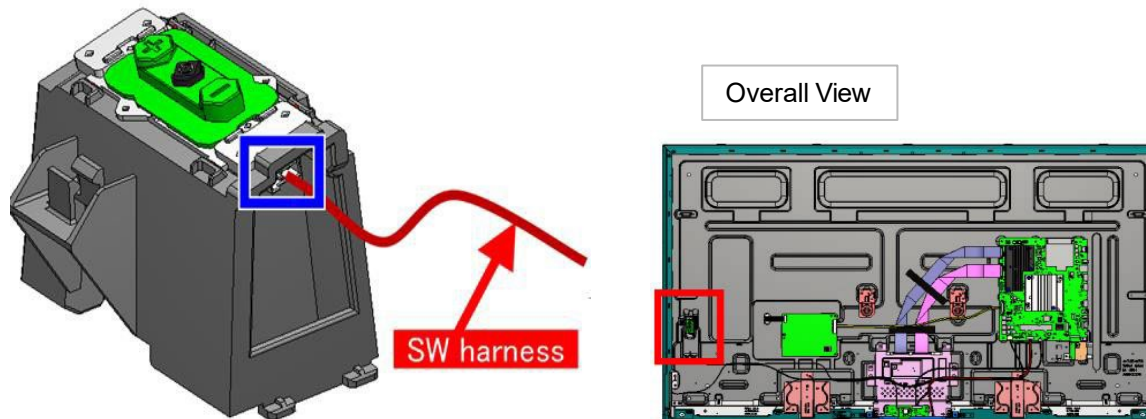

2.2 Wire Dressing : 49”

TAPE

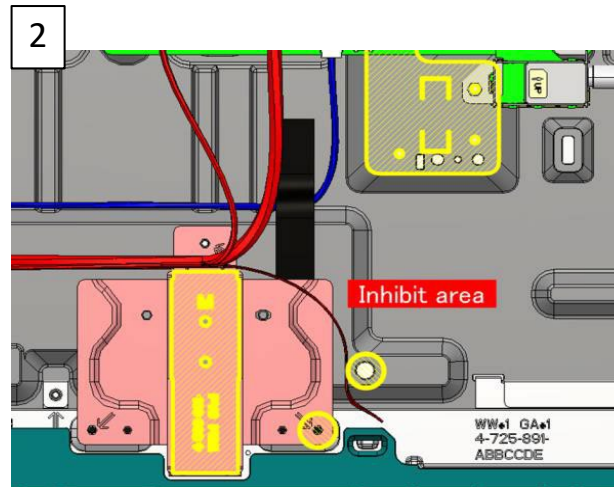
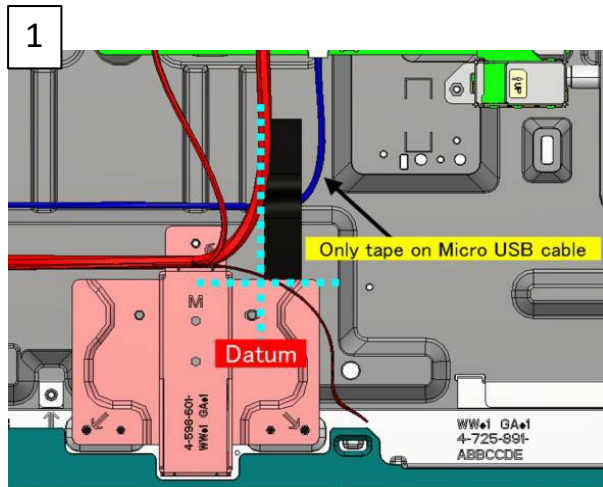

Overall View

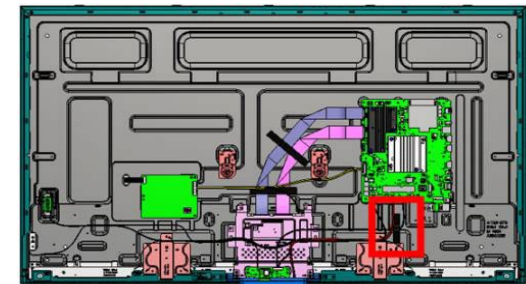

TAPE

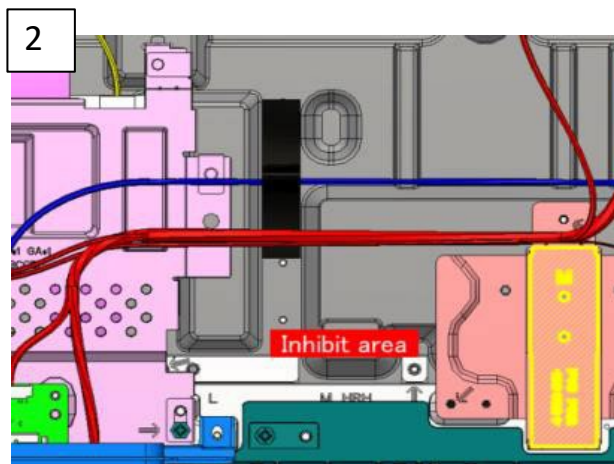
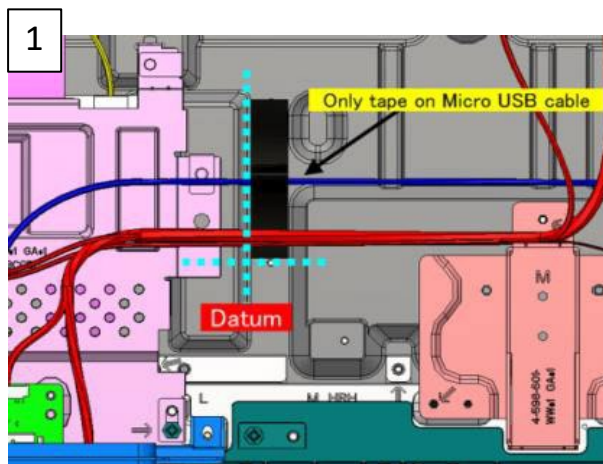

Overall View

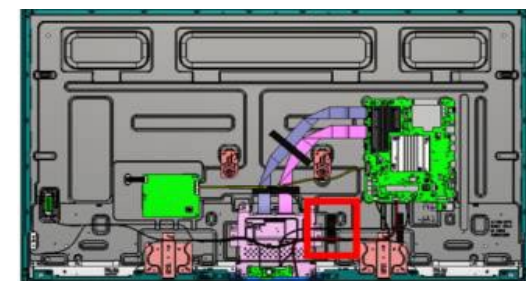

2.2 Wire Dressing : 49”

TAPE

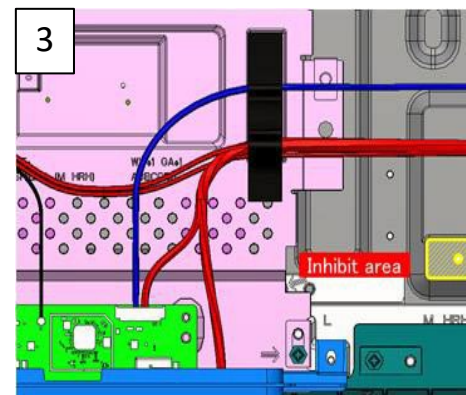
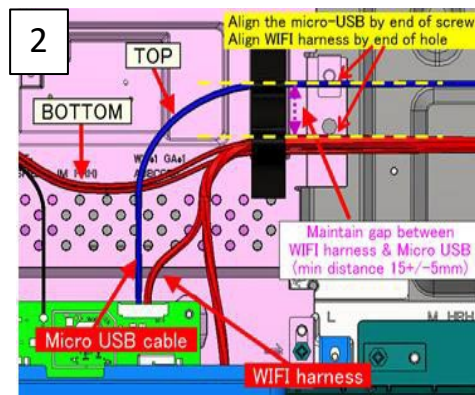
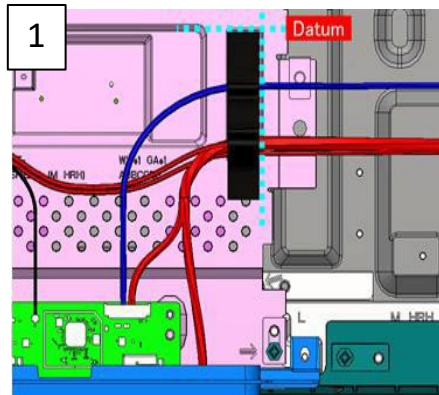

Overall View

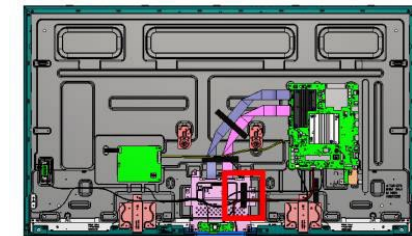

TAPE

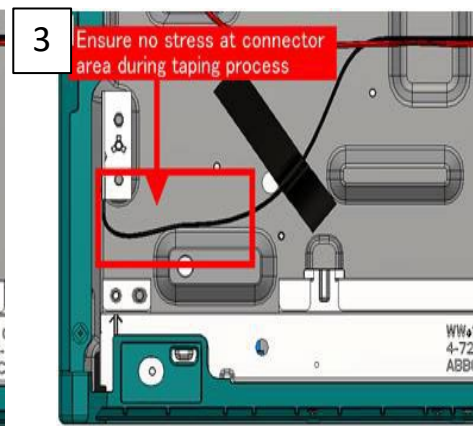
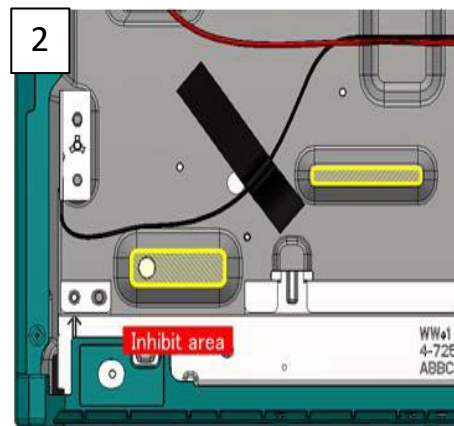
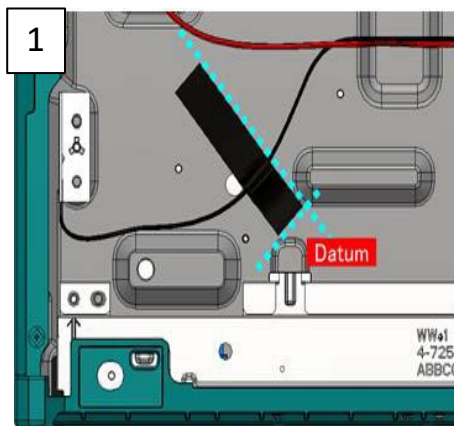

Overall View

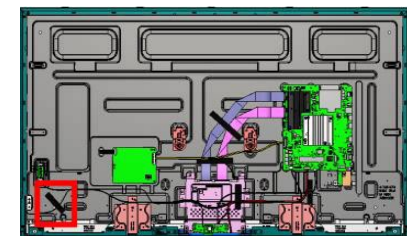

2.2 Wire Dressing : 49"

TAPE

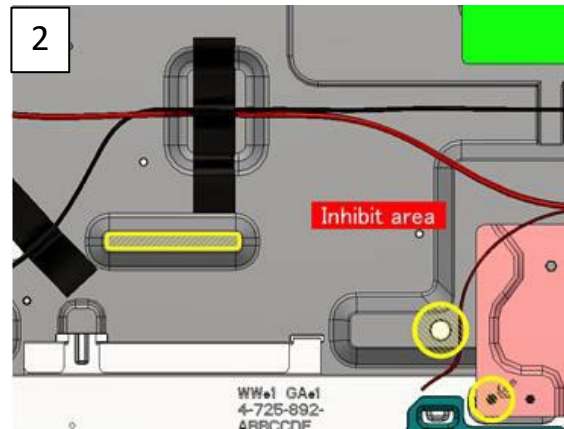
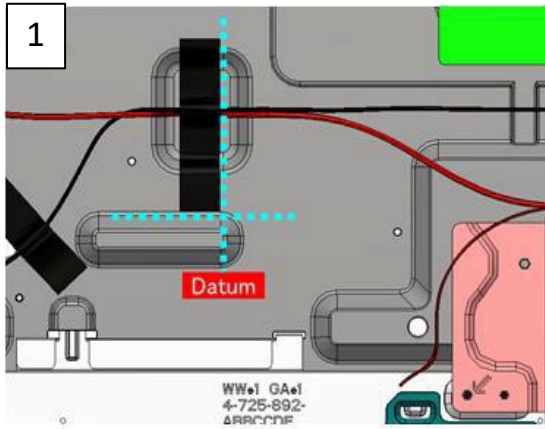

Overall View

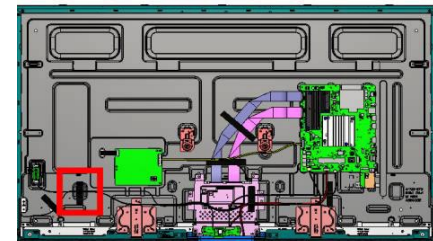

TAPE

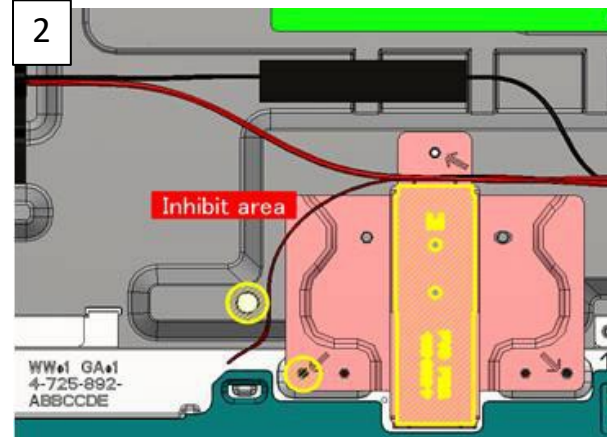
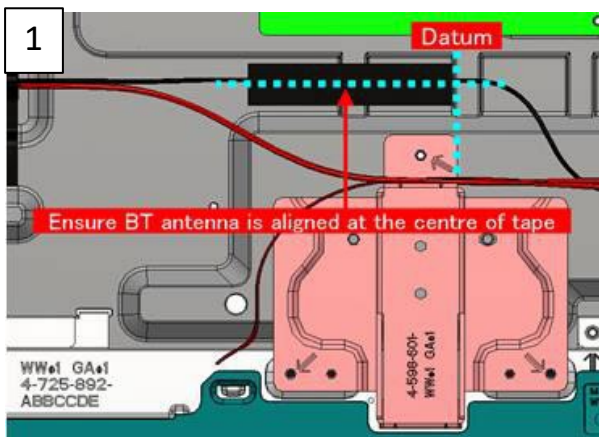

Overall View

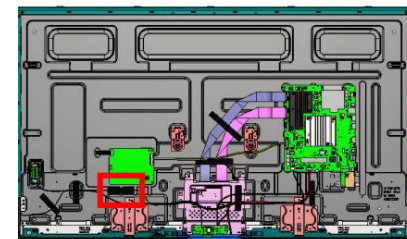

2.2 Wire Dressing : 49"

TAPE

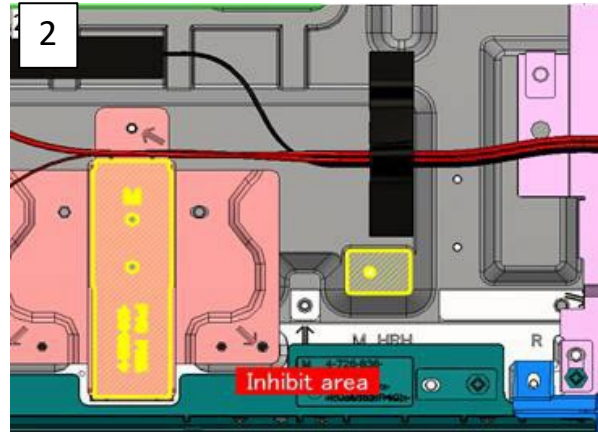
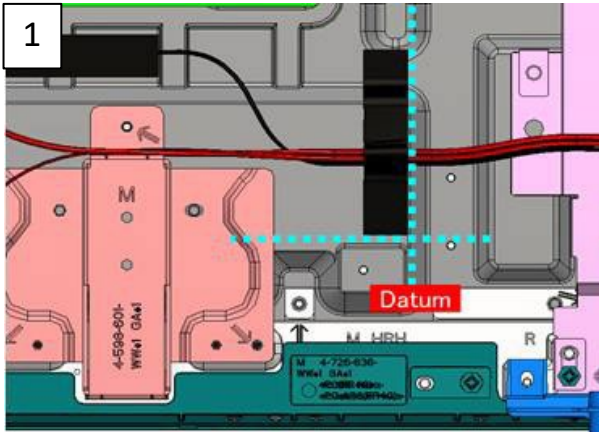

Overall View

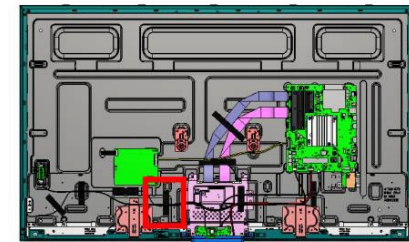

TAPE

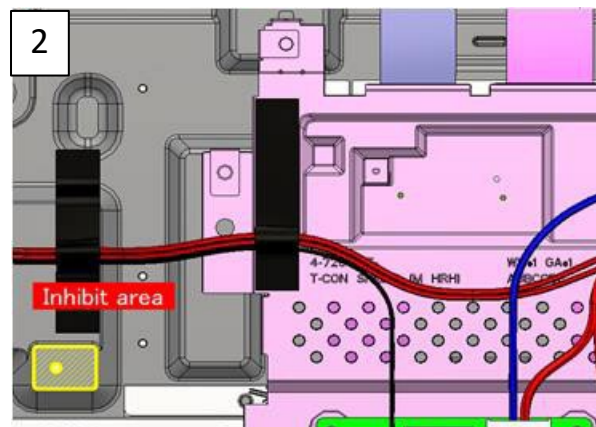
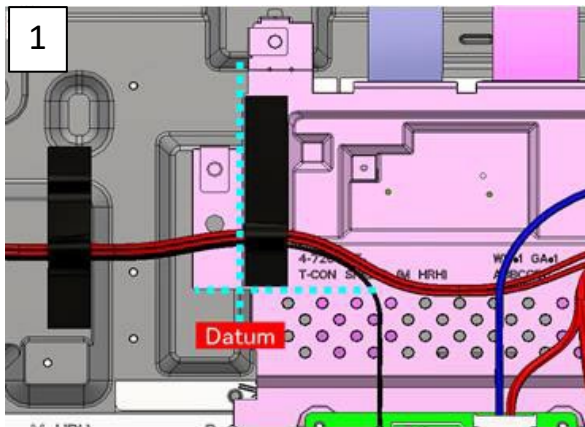

Overall View

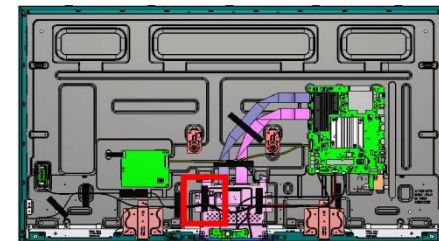

2.2 Wire Dressing : 49”

INFORMATION

Harness Dressing at T-Con Area

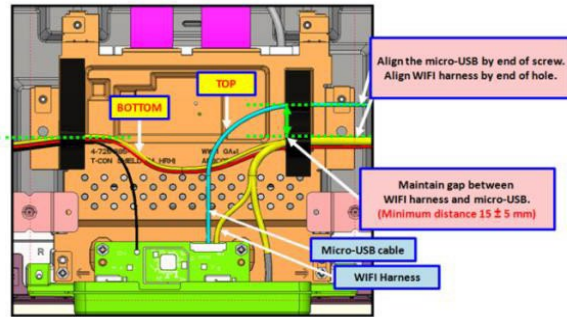

INFORMATION

CAUTION:
 1. Ensure micro-USB and WIFI harness is not in twisted condition.
 2. Ensure the dressing of micro-USB on top of Speaker (R) harness with correct datum.

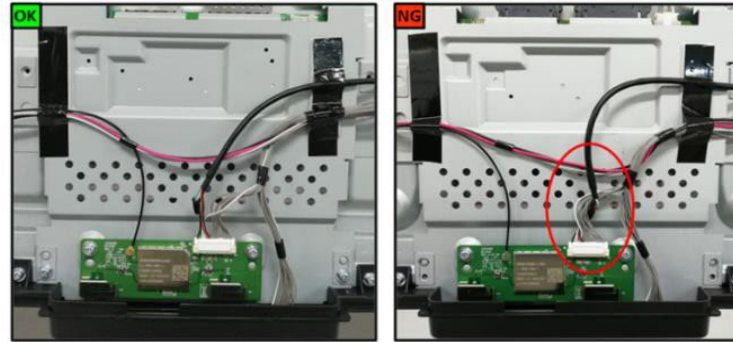

CONNECT

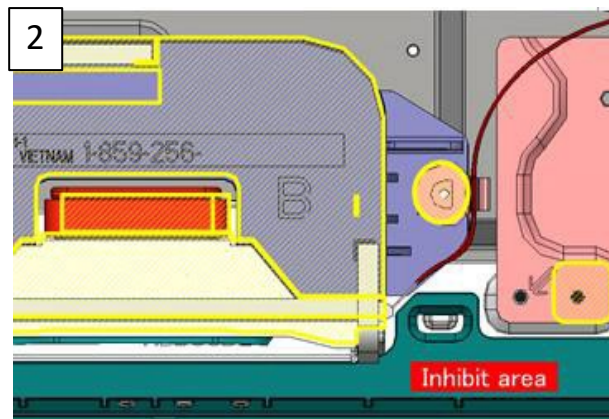
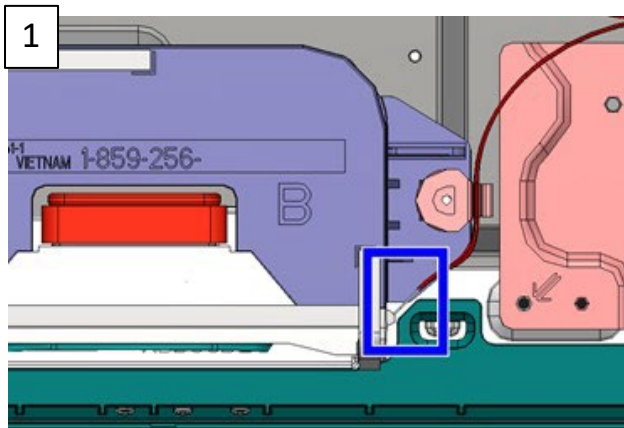

Overall View

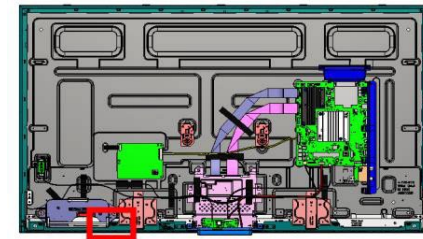

2.2 Wire Dressing : 49”

WIRE DRESSING

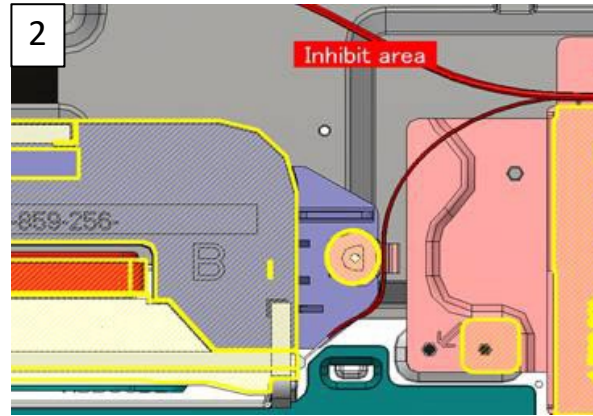
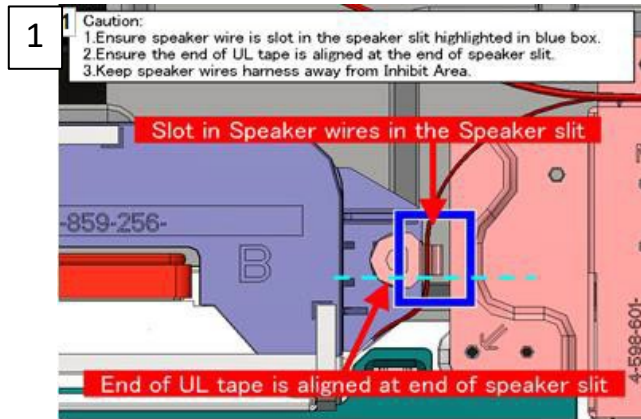

Overall View

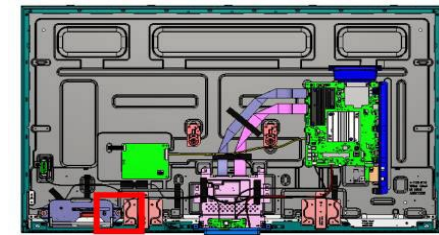

CONNECT

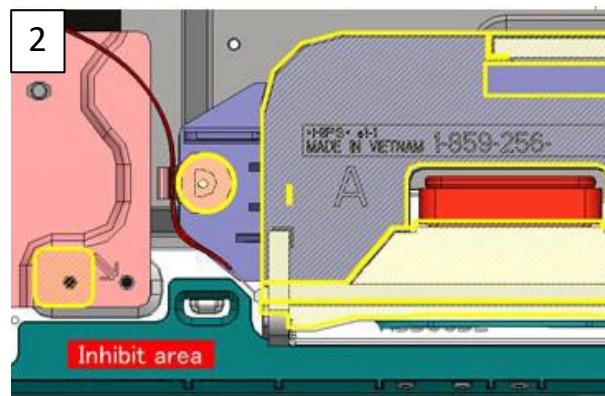
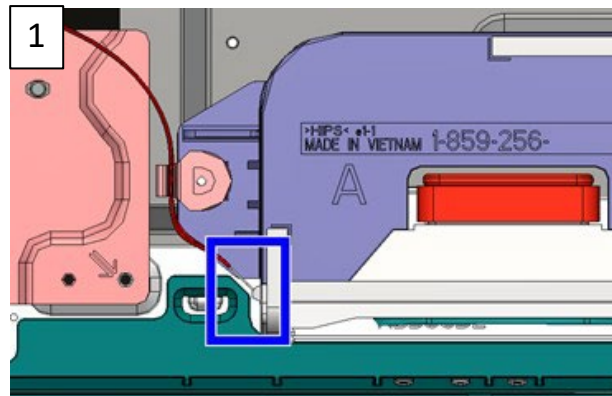

Overall View

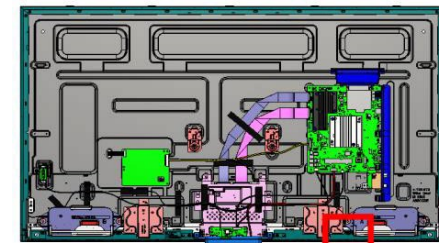

2.2 Wire Dressing : 49”

WIRE DRESSING

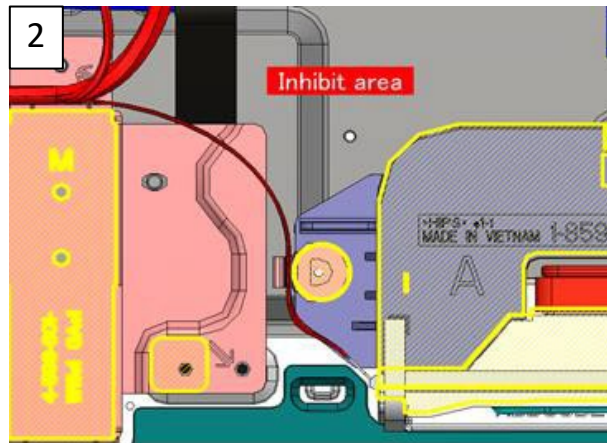
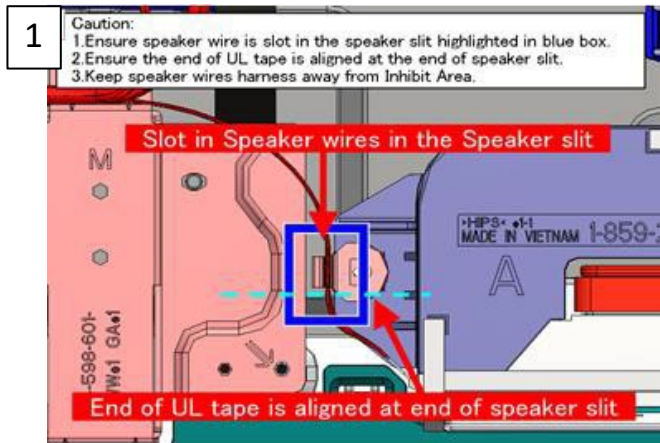

Overall View

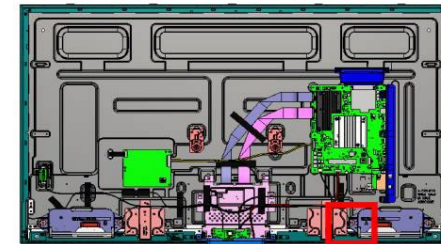

INFORMATION

CHH only

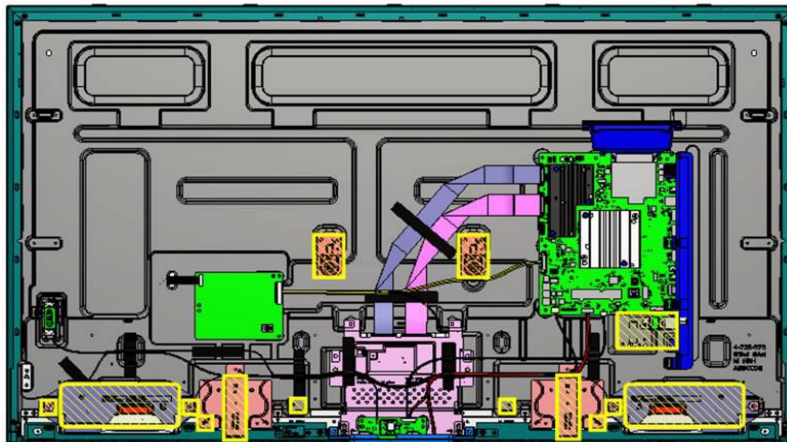

INFORMATION

CHHB only

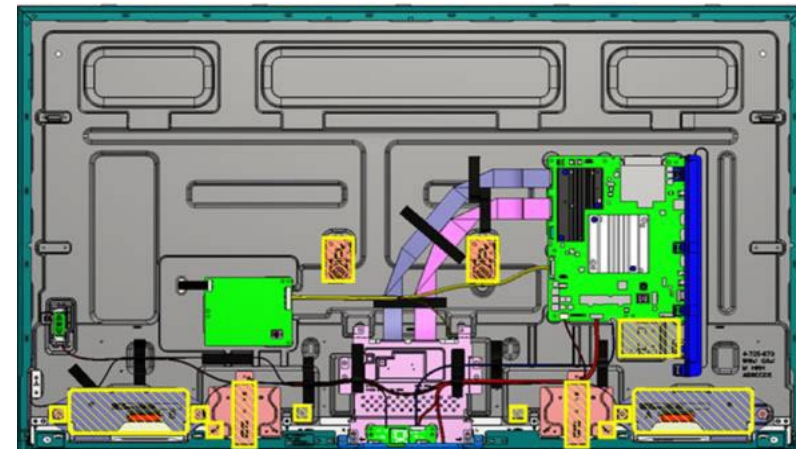

SECTION 3 EXPLODED VIEWS AND PARTS LIST

- Place the TV set facing downwards on a stable, level surface before disassembly and assembly of parts.
- and shaded parts are critical for safety. Replace only with part number specified.
- Parts contain confidential information. Strictly follow the instruction whenever the components are repaired and/or replaced.

- (*) Parts are not stocked since they are seldom required for routine service. Some delays should be anticipated when ordering these components.
- Picture provided in this section might have slight difference from the actual sets.
- Lines that indicate parts are shown in blue in the illustration.
- The reference number beside the part description indicates the disassembly sequence.
- Remove screws before disassembly. Unplug connectors before disassembly

3-1. FW-43BZ35F

Exploded View

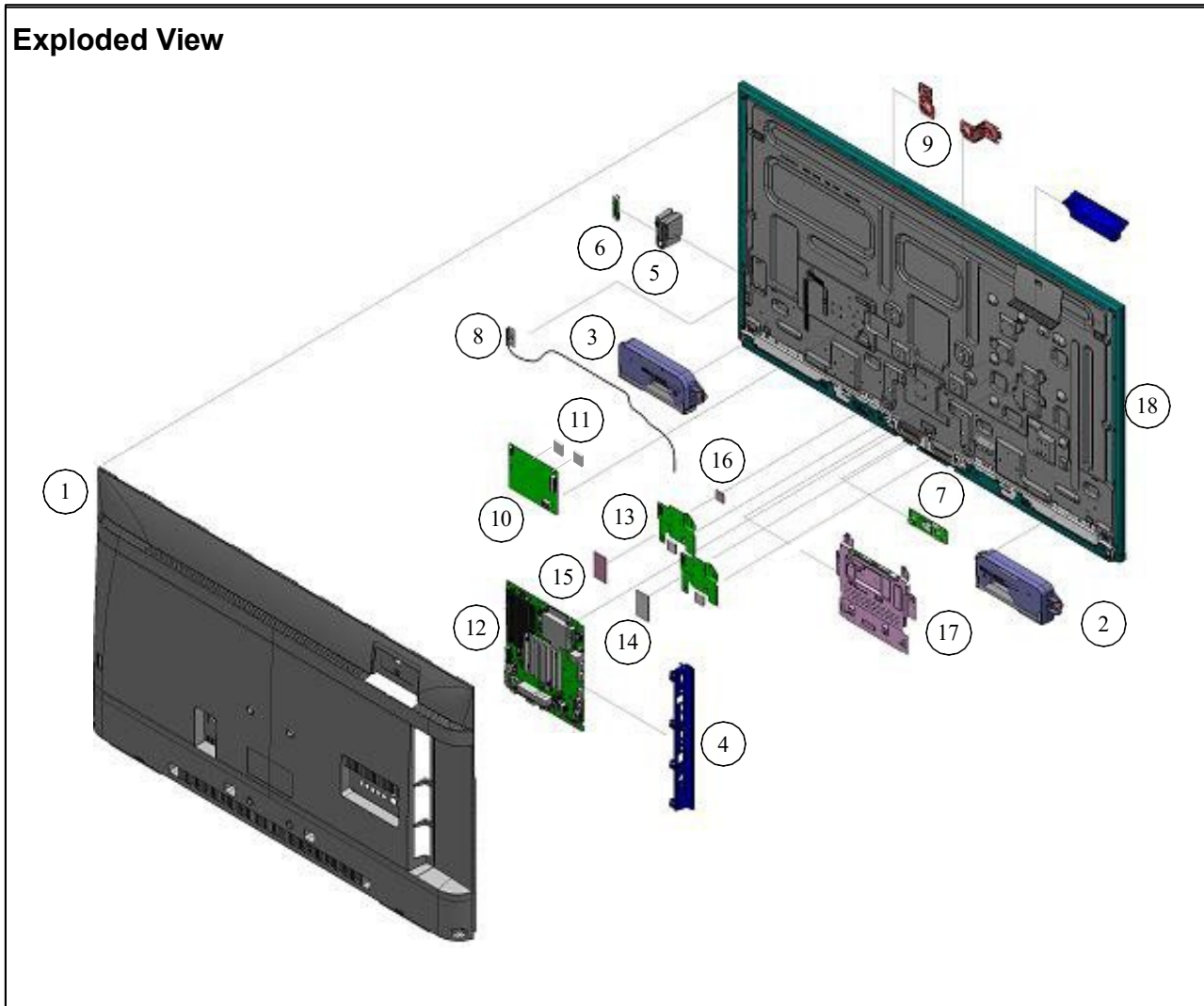

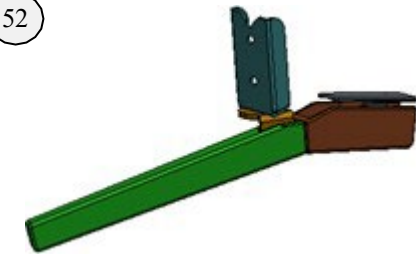

Stand

(51) (52)



3-1. FW-43BZ35F

Exploded View

REF. NO.	PART NO.	DESCRIPTION	FW-43BZ35F
			UC2
1	4-729-459-02	REAR COVER (SM HRH) A	•
2	1-859-256-11	SP-BOX ASSY,FY18 W30SMALL-A	•
3	1-859-256-21	SP-BOX ASSY,FY18 W30SMALL-B	•
4	4-726-393-61	BRACKET SIDE (HRH)	•
5	4-726-502-01	BRACKET, SWITCH (PPK)	•
6	1-474-647-12	SWITCH UNIT (3M-P)	•
7 	1-458-998-11	WLAN/BT MODULE(11AC)	•
8	1-522-046-11	BT ANTENNA 540MM FXC	•
9	4-595-898-01	VESA BRACKET BT (SM FRE)	•
10	A-2201-090-A	LD2_2DRV_43_OTHER MOUNT	•
11	4-549-186-02	SHEET, THERMAL(BM)	•
12 	A-2201-063-A	COMPL_SVC_BCH_B2B_WW	•
13	4-699-975-01	SHEET,THERMAL(5567H)	•
14	4-735-955-01	SHEET, THERMAL(MUF HRH)	•
15	4-735-956-01	SHEET, THERMAL(FRC HRH)	•
16	4-735-957-01	SHEET, THERMAL(FRC HRH B)	•
17	1-897-264-11	MOUNTED PWB E-T-CON (43)	•
18 	A-2198-884-A	P-MOD (YD8S430HNG0101)(SERVICE	n/a
51	4-729-457-01	STAND L (SM HRH) A	•
52	4-729-458-01	STAND R (SM HRH) A	•

3-1. FW-43BZ35F

Screws

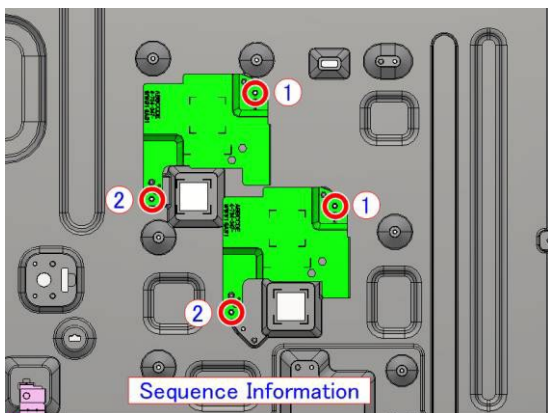

SCREW, +PSW M3X6	4-472-518-11
------------------	--------------

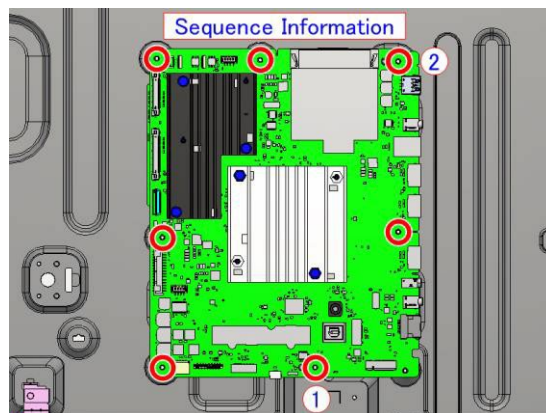

SCREW, +PSW M3X6	4-472-518-11
------------------	--------------

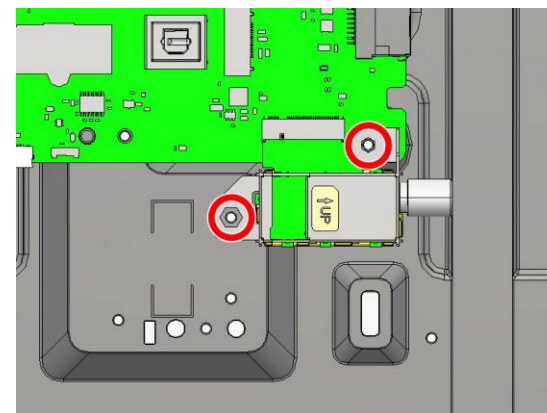

SCREW, +PSW M3X6	4-472-518-11
------------------	--------------

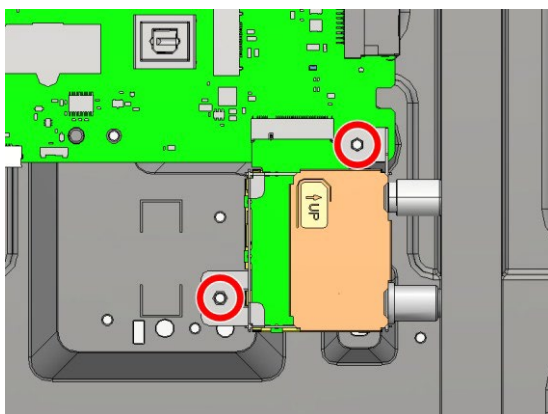

SCREW, +PSW M3X6	4-472-518-11
------------------	--------------

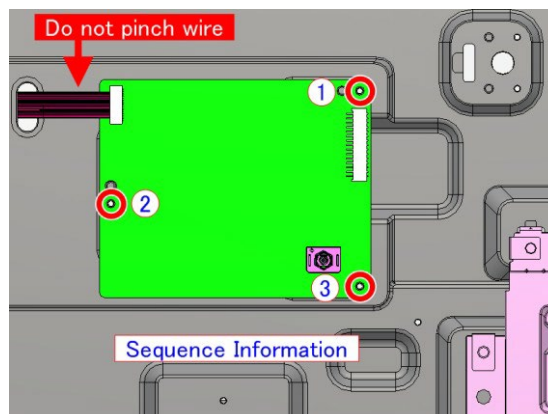

SCREW, +PSW M3X6	4-472-518-11
------------------	--------------

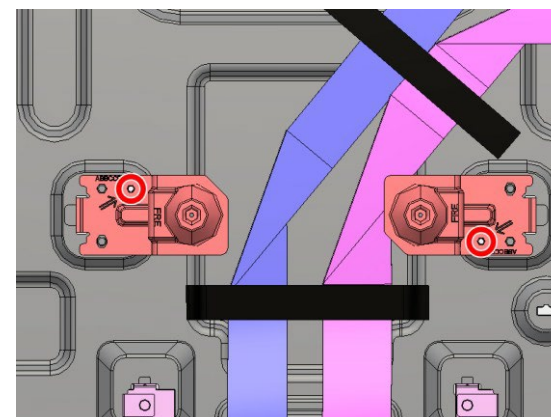

SCREW, +PSW M3X6	4-472-518-11
------------------	--------------

3-1. FW-43BZ35F

Screws

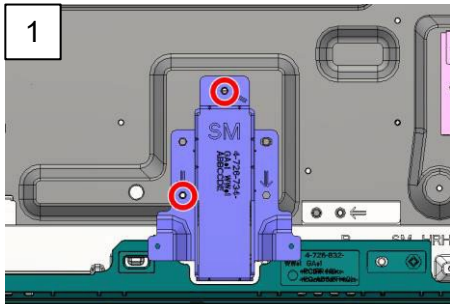

Screw position at right side

SCREW, +PSW M3X6

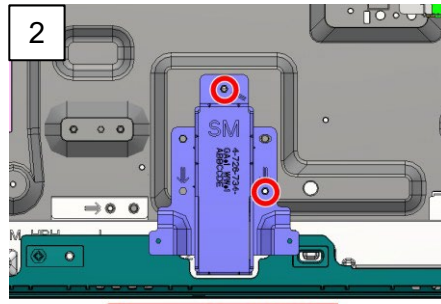

Screw position at left side

4-472-518-11

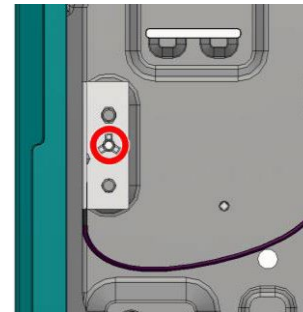

SCREW, +PSW M3X6

4-472-518-11

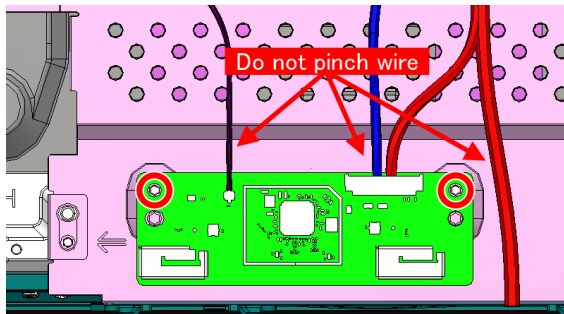

SCREW, +PSW M3X6

4-472-518-11

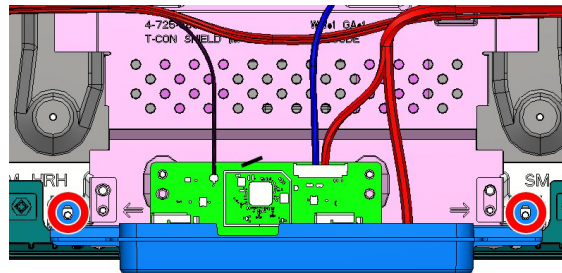

SCREW, +PSW M3X6

4-472-518-11

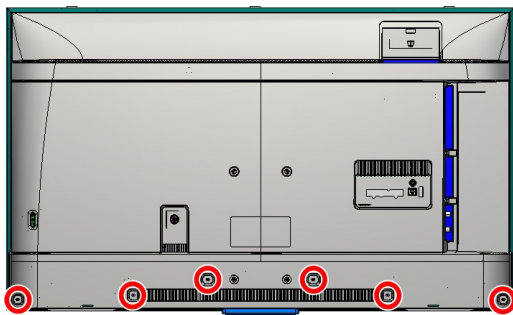

SCREW, +PSW M3X8

4-167-019-22

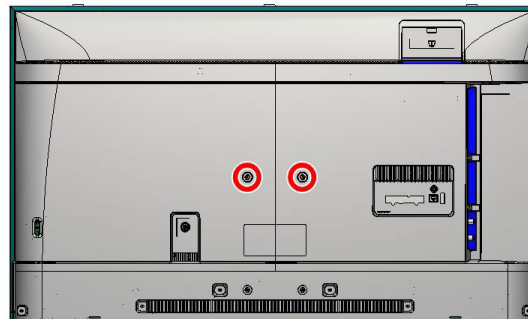

SCREW, ORNAMENTAL M6X12

4-268-126-02

3-1. FW-43BZ35F

Connectors

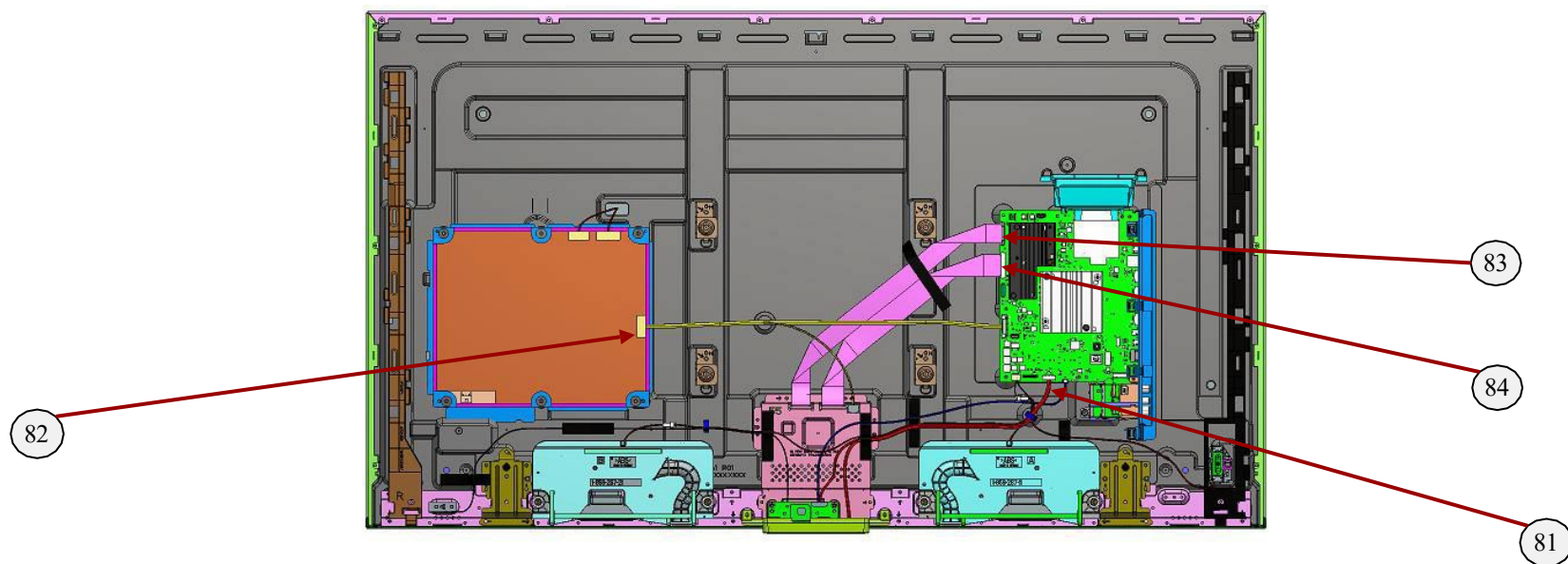

REF. NO.	PART NO.	DESCRIPTION	REMARKS
81	1-910-806-32	HARNESS ASSY	CN1000 (BCH)-CN1(3M-P)-CN001 (HCA)-WIFI/BT-CN1002 (BCH)/CN3201(BCH)-SP(1)
82	1-910-806-34	CONNECTOR ASSY 30P	CN400(BCH)-CN3000(LD2)-J110(T-CON)(1)
83	1-912-527-11	FLEXIBLE FLAT CABLE 41P	CN4400(BCH)-U2(T-CON)(1)
84	1-912-556-11	FLEXIBLE FLAT CABLE 51P	CN4401(BCH)-U1(T-CON)(1)

3-1. FW-43BZ35F

Other parts

PART NO.	DESCRIPTION	FW-43BZ35F
1-493-490-21	AC ADAPTOR (120W)	•
*7-600-040-44	ADHESIVE (SV380C) 333CC GRY	•
4-535-064-14	ASSY,FALL LOCK,BELT LL	•
4-588-089-03	BAG, SCREW ASSY (TQS) (*include SCREW, +PSW M4X12 2-580-602-01 (4pcs))	•
*4-548-743-01	HOLDER, HS WS (MUF)	•
*4-549-188-01	HOLDER(HS MUF)	•
A-2198-900-A	HEAT SPREADER (SERVICE)43CHH/B	•
*4-549-395-01	HEAT SINK (MUFF C)	•
*4-584-547-01	HEAT SINK(MUFF2 C)	•
4-732-834-01	LABEL, REAR TERMINAL (HRH)	•
4-731-521-51	LABEL, SIDE TERMINAL (HRH)	•
1-849-876-11	POWER-SUPPLY CORD SET	•
*4-734-761-21	PROFESSIONAL GUIDE (B2B)	•
1-493-483-11	REMOTE COMMANDER (RMT-TB400U)	•
*4-735-232-11	REFERENCE GUIDE	•
*4-735-249-11	SETUP GUIDE	•
*A-2218-237-A	USER GUIDE CHHB UC2	•



SECTION 3 EXPLODED VIEWS AND PARTS LIST

- Place the TV set facing downwards on a stable, level surface before disassembly and assembly of parts.
- and shaded parts are critical for safety. Replace only with part number specified.
- Parts contain confidential information. Strictly follow the instruction whenever the components are repaired and/or replaced.

- (*) Parts are not stocked since they are seldom required for routine service. Some delays should be anticipated when ordering these components.
- Picture provided in this section might have slight difference from the actual sets.
- Lines that indicate parts are shown in blue in the illustration.
- The reference number beside the part description indicates the disassembly sequence.
- Remove screws before disassembly. Unplug connectors before disassembly

3-2. FW-49BZ35F

Exploded View

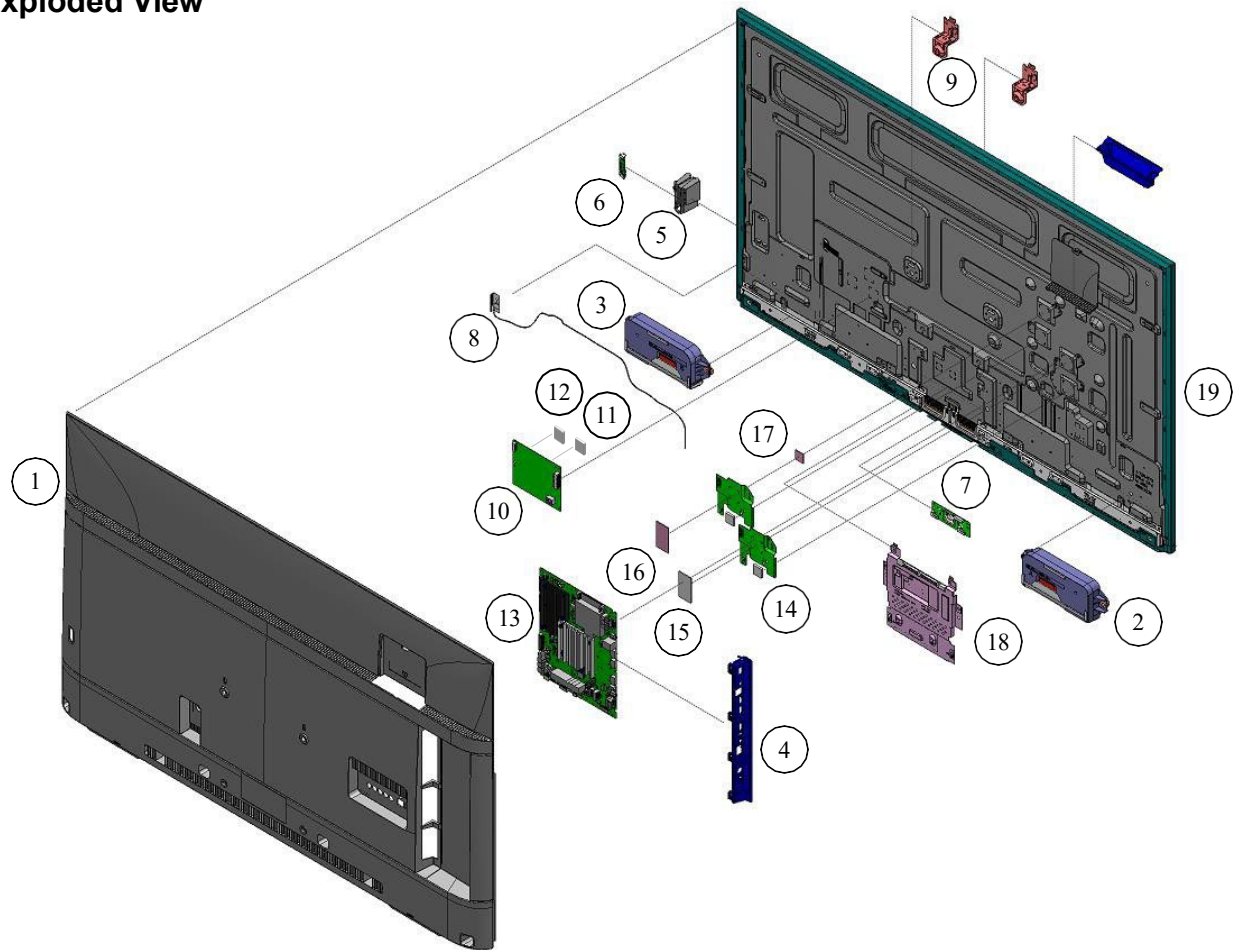

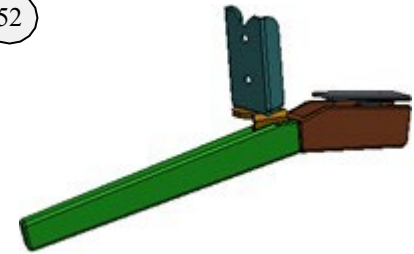

Stand

(51) (52)



3-2. FW-49BZ35F

Exploded View

REF. NO.	PART NO.	DESCRIPTION	FW-49BZ35F
			UC2
1	4-729-460-01	REAR COVER (M HRH) A	•
2	1-859-256-11	SP-BOX ASSY,FY18 W30SMALL-A	•
3	1-859-256-21	SP-BOX ASSY,FY18 W30SMALL-B	•
4	4-726-393-61	BRACKET SIDE (HRH)	•
5	4-726-502-01	BRACKET, SWITCH (PPK)	•
6	1-474-647-12	SWITCH UNIT (3M-P)	•
7 	1-458-998-11	WLAN/BT MODULE(11AC)	•
8	1-754-950-12	BT ANTENNA 540MM FXC	•
9	4-595-898-01	VESA BRACKET BT (SM FRE)	•
10	A-2201-092-A	LD2_2DRV_49_OTHER MOUNT	•
11	4-549-186-02	SHEET, THERMAL(BM)	•
12	4-684-341-01	SHEET THERMAL (MZT LD)	•
13 	A-2201-063-A	COMPL_SVC_BCH_B2B_WW	•
14	4-699-975-01	SHEET, THERMAL(5567H)	•
15	4-735-955-01	SHEET, THERMAL(MUF HRH)	•
16	4-735-956-01	SHEET, THERMAL(FRC HRH)	•
17	4-735-957-01	SHEET, THERMAL(FRC HRH B)	•
18	1-897-275-11	MOUNTED PWB E-T-CON (49)	•
19 	A-2198-882-A	P-MOD (YD8S490HND0101)(SERVICE	n/a
51	4-734-881-01	STAND L (M HRH) A	•
52	4-734-882-01	STAND R (M HRH) A	•

3-2. FW-49BZ35F

Screws

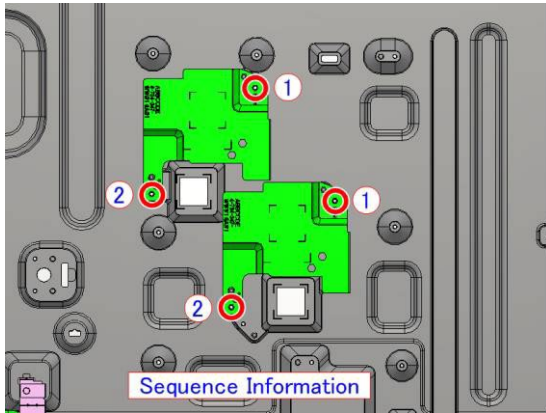

SCREW, +PSW M3X6	4-472-518-11
------------------	--------------

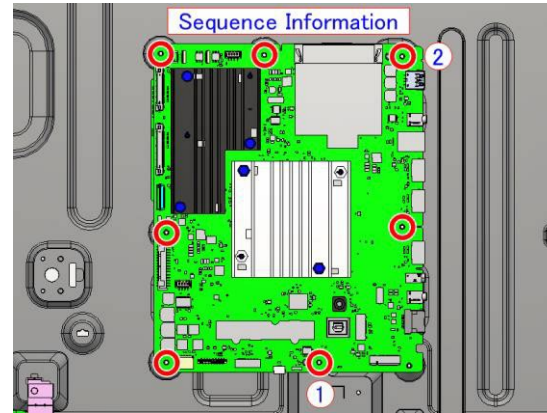

SCREW, +PSW M3X6	4-472-518-11
------------------	--------------

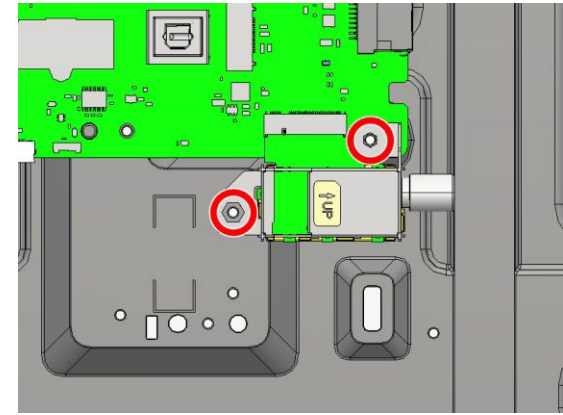

SCREW, +PSW M3X6	4-472-518-11
------------------	--------------

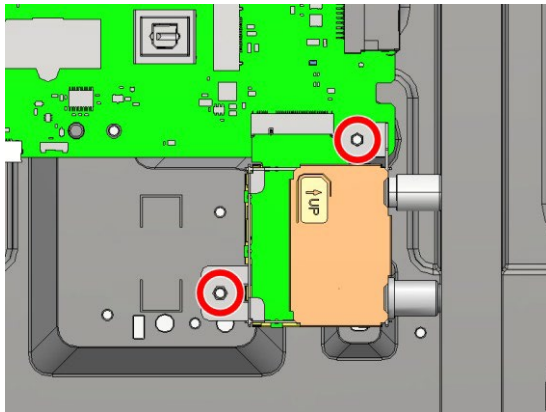

SCREW, +PSW M3X6	4-472-518-11
------------------	--------------

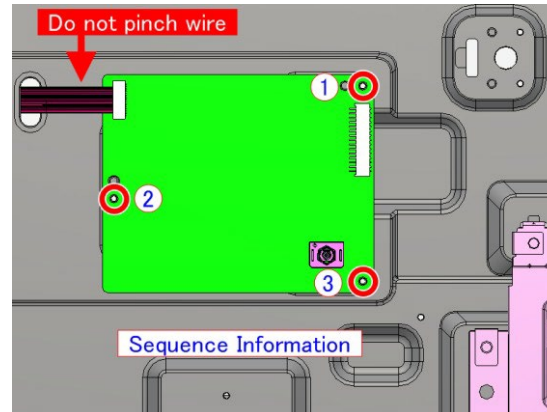

SCREW, +PSW M3X6	4-472-518-11
------------------	--------------

3-2. FW-49BZ35F

Screws

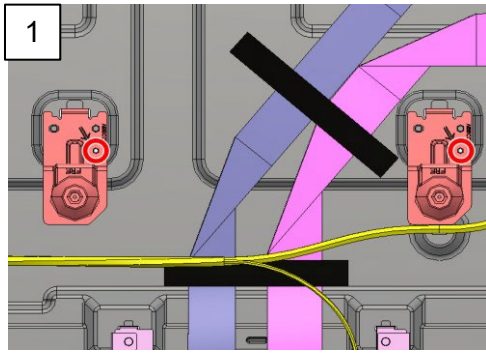

SCREW, +PSW M3X6

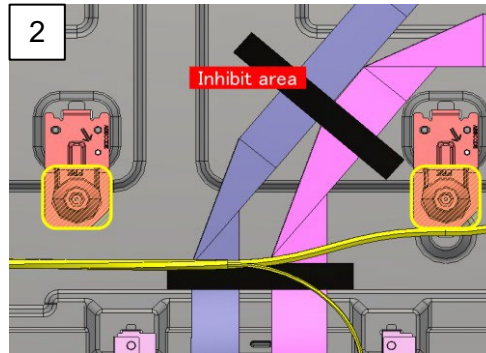

4-472-518-11

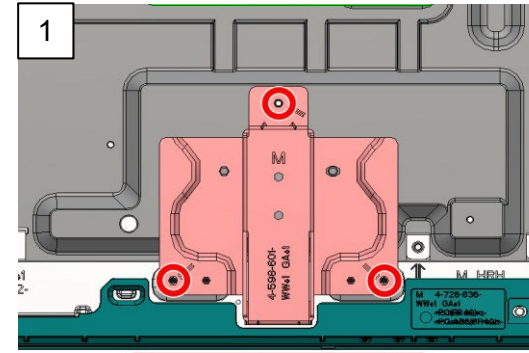

Screw position at right side

SCREW, +PSW M3X6

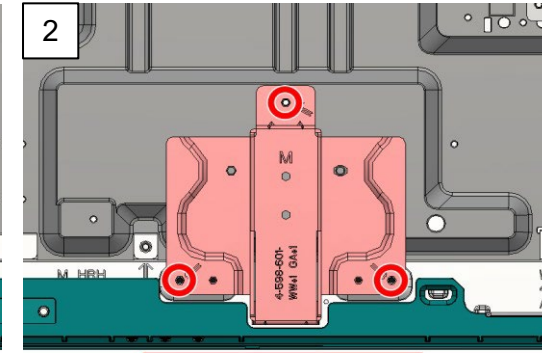

Screw position at left side

4-472-518-11

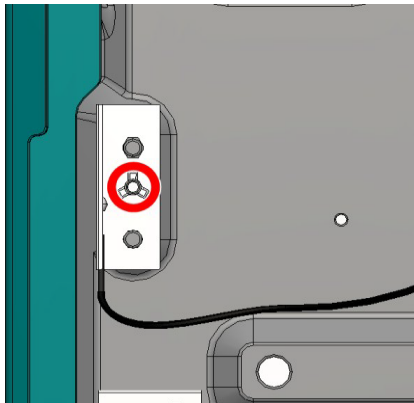

SCREW, +PSW M3X6

4-472-518-11

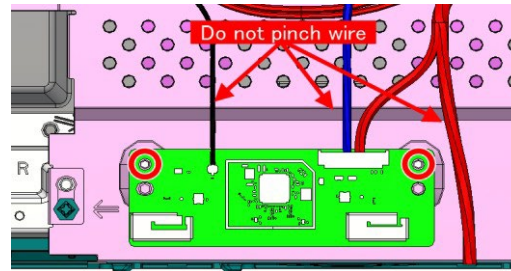

SCREW, +PSW M3X6

4-472-518-11

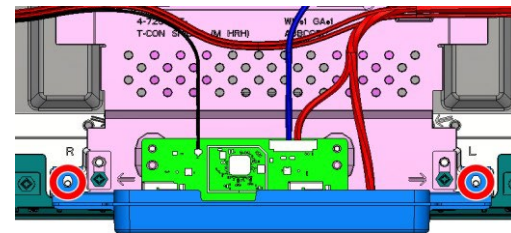

SCREW, +PSW M3X6

4-472-518-11

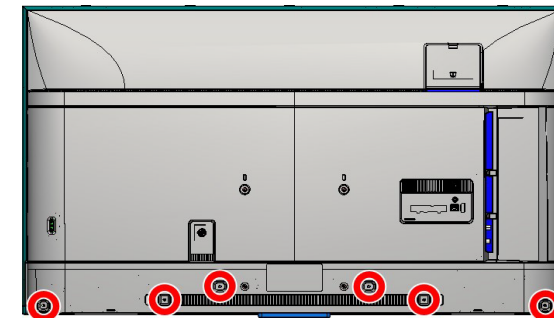

SCREW, +PSW M3X8

4-167-019-22

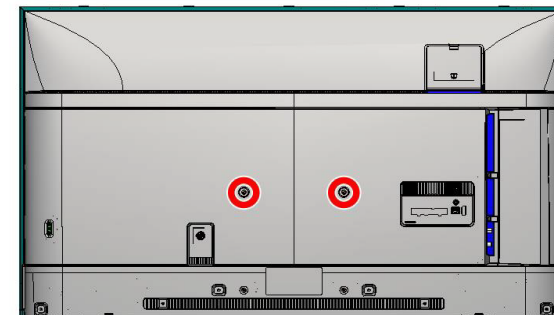

SCREW, ORNAMENTAL M6X12

4-268-126-02

3-2. FW-49BZ35F

Screws

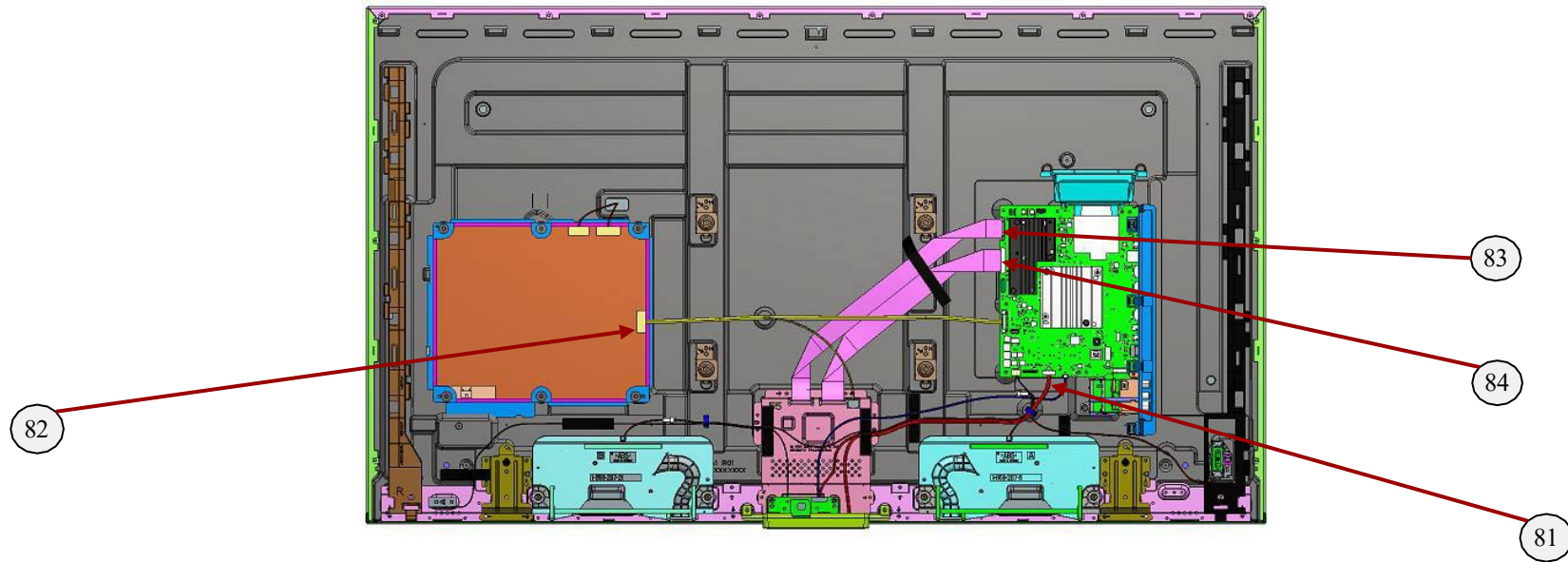

REF NO	PART NO.	DESCRIPTION	REMARKS
81	1-910-806-35	HARNESS ASSY	CN1000(BCH)-CN1(3M-P)-CN001(HCA)-WIFI/BT-CN1002(BCH)/CN3201(BCH)-SP(1)
82	1-910-806-37	CONNECTOR ASSY 30P	CN400(BCH)-CN3000(LD2)-J110(T-CON)(1)
83	1-912-544-11	FLEXIBLE FLAT CABLE 41P	CN4400(BCH)-U2(T-CON)(1)
84	1-912-546-11	FLEXIBLE FLAT CABLE 51P	CN4401(BCH)-U1(T-CON)(1)

3-2. FW-49BZ35F

Others part

PART NO.	DESCRIPTION	FW-49BZ35F
		UC2
1-493-297-12	AC ADAPTOR (160W)	•
*7-600-040-44	ADHESIVE (SV380C) 333CC GRY	•
4-535-064-14	ASSY,FALL LOCK,BELT LL	•
4-588-089-03	BAG, SCREW ASSY (TQS) (*include SCREW, +PSW M4X12 2-580-602-01 (4pcs))	•
A-2198-898-A	HEAT SPREADER (SERVICE)49CHH/B	•
*4-548-743-01	HOLDER, HS WS (MUF)	•
*4-549-188-01	HOLDER(HS MUF)	•
4-732-834-01	LABEL, REAR TERMINAL (HRH)	•
4-731-521-51	LABEL, SIDE TERMINAL (HRH)	•
 1-849-876-11	POWER-SUPPLY CORD SET	•
*4-549-395-01	HEAT SINK (MUFF C)	•
*4-584-547-01	HEAT SINK(MUFF2 C)	•
*4-734-761-21	PROFESSIONAL GUIDE (B2B)	•
1-493-483-11	REMOTE COMMANDER (RMT-TB400U)	•
*4-735-232-11	REFERENCE GUIDE	•
*4-735-249-11	SETUP GUIDE	•
*A-2218-237-A	USER GUIDE CHHB UC2	•

3-3. Smart core

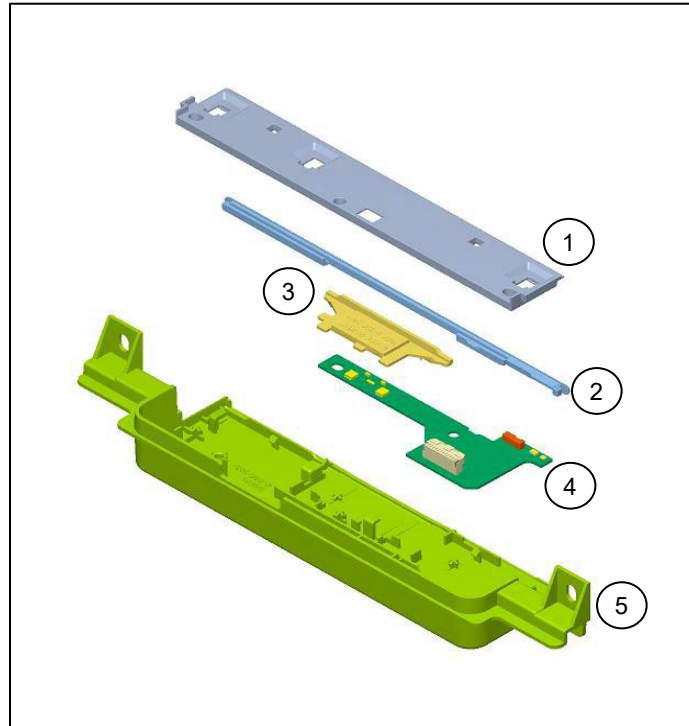

REF.NO.	PART NO.	DESCRIPTION
1	4-724-440-01	COVER, TOP (HRH)
2	4-596-101-21	PANEL, ORNAMENT (FRE)
3	4-596-102-01	GUIDE, LIGHT (FRE)
4	A-2199-558-A	HCA_M2_PONR MOUNT (65" & 75" only)
4	A-2199-646-A	HCAL_M2_PONR MOUNT (85" only)
5	4-596-103-02	CASE, BOTTOM (FRE)

